

# Welch Allyn ® SCANTEAM® 6920

PC XT-AT-PS/2 Keyboard Wedge  
Magnetic Stripe Card Reader

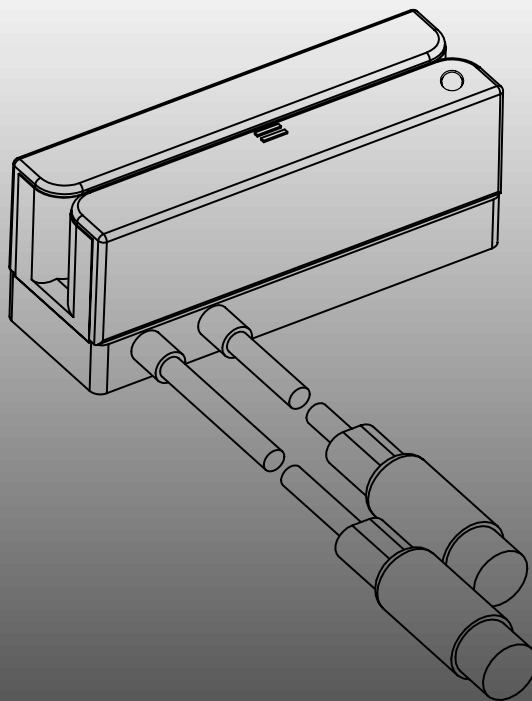

## User's Guide

*Please Note: Finished document will be 5.5x8.5inches,  
3-hole punched, folded and stapled.*

© 1998 Welch Allyn, Inc. All rights reserved.

## Statements of Agency Compliance

This device complies with part 15 of the FCC Rules. Operation is subject to the following two conditions: (1) this device may not cause harmful interference, and (2) this device must accept any interference received, including interference that may cause undesired operation.

### **FCC Class A Compliance Statement**

This equipment has been tested and found to comply with the limits for a Class A digital device, pursuant to part 15 of the FCC Rules. These limits are designed to provide reasonable protection against harmful interference when the equipment is operated in a commercial environment. This equipment generates, uses, and can radiate radio frequency energy and, if not installed and used in accordance with the instruction manual, may cause harmful interference to radio communications. Operation of this equipment in a residential area is likely to cause harmful interference, in which case the user will be required to correct the interference at his own expense.

**Caution: Any changes or modifications made to this device that are not expressly approved by Welch Allyn, Inc. may void the user's authority to operate the equipment.**

**Note:** To maintain compliance with FCC Rules and Regulations, cables connected to this device must be *shielded* cables, in which the cable shield wire(s) have been grounded (tied) to the connector shell.

### **Canadian Notice**

This equipment does not exceed the Class A limits for radio noise emissions as described in the Radio Interference Regulations of the Canadian Department of Communications.

Le present appareil numerique n'emet pas de bruits radioelectriques depassant les limites applicables aux appareils numeriques de la classe A prescrites dans le Reglement sur le brouillage radioelectrique edicte par le ministere des Communications du Canada.



The CE mark on the product indicates that the system has been tested to and conforms with the provisions noted within the 89/336/EEC Electromagnetic Compatibility Directive.

## TABLE OF CONTENTS

---

---

<i>Section</i>	<i>Page</i>
Statements of Agency Compliance	
Introduction .....	1
Features / Benefits .....	2
Applications .....	3
Configurations .....	3
Installation .....	4
Output Data Format .....	5
Configuration Options: Dip Switch Controlled ..	6
Accessing the 6920 DIP Switch .....	7
Dip Switch Feature Selection .....	8
Configuration Options: Keyboard Programmable	9
Specifications .....	15
Pin Assignments .....	16
Service and Technical Support .....	17
Help Desk .....	18
Limited Warranty (inside back cover)	

---

**Disclaimer**

Welch Allyn<sup>®</sup> reserves the right to make changes in specifications and other information contained in this document without prior notice, and the reader should in all cases consult Welch Allyn to determine whether any such changes have been made. The information in this publication does not represent a commitment on the part of Welch Allyn.

**Welch Allyn shall not be liable for technical or editorial errors or omissions contained herein; nor for incidental or consequential damages resulting from the furnishing, performance, or use of this material.**

This document contains proprietary information which is protected by copyright. All rights are reserved. No part of this document may be photocopied, reproduced, or translated into another language without the prior written consent of Welch Allyn, Incorporated.

# **INTRODUCTION TO THE SCANTEAM 6920 1**

---

---

## **Introduction**

The SCANTEAM® 6920 products are decoded output Magnetic Stripe card Readers (MSRs) which attach to Personal Computer (PC) products through a keyboard wedge interface. All magnetic stripe decoding and wedge electronics are contained in the compact SCANTEAM 6920 enclosure. The magnetic stripe data transmitted by the SCANTEAM 6920 to the PC emulates keyboard data input, so that for many applications, no PC program modification is required to input data from the SCANTEAM 6920.

The SCANTEAM 6920 is a bi-directional card reader, that is, it can read cards swiped in either direction through the card reader. The beeper and the LED included in the SCANTEAM 6920 indicate a good read or bad read to the operator. Versions are available which allow decoding single, dual, and triple track magnetic stripe cards.

---

## Features / Benefits

### Compact Size

- Mounts easily on keyboard or any flat surface. (hook and loop fastener installation kit included.)

### Universal PC Keyboard Wedge Interface

- No hardware or software modification to PC system required to add magnetic stripe reading capability.
- All versions of the SCANTEAM 6920 are compatible with PC XT, AT, or PS/2 host devices. Universal interface feature reduces need to inventory multiple product types.

### Powered By PC Keyboard Port

- No external power pack required.

### Bi-directional Card Read

- Ease of use, reduces training time, allows greater flexibility in mounting device.
- User can enable or disable data tracks.

### Auto detection of “Caps Lock” Key State on the Host PC

- Allows magnetic stripe data to always be provided to the host application in upper case characters, regardless of the state of the “Caps Lock” key.

### Good Read / Bad Track / Error LED and Beeper

- Provides feedback to operator to indicating the following:

<i>Normal Operation</i>	Green LED
<i>Programming Mode</i>	LED off (LED will flash and beeper will sound once as each command key is pressed during programming)
<i>Good Read</i>	Green LED blinks and single beep
<i>Bad or Missing Track</i>	Orange LED and double beep
<i>Error</i>	Red LED and triple beep

### Up to Five Programmable Prefix/Suffix Characters

- Customize your magnetic stripe data for your specific application.

---

## Applications

The SCANTEAM 6920 offers a fast, easy, and accurate method of entering data contained on a magnetic stripe into a PC system. Retail POS credit and debit account number entry, bank teller automation, membership ID verification, access control, work-in-process data entry, labor and job tracking, and tool and equipment sign out are just a few of the possible applications for the SCANTEAM 6920.

## Configurations

Single Track		
Model #	Mag Track	Host Interface: Connector Compatibility
6920-2 †	2	XT-AT-PS/2: Full-Sized Circular DIN
Dual Track		
Model #	Mag Tracks	Host Interface: Connector Compatibility
6920-1	1 and/or 2	XT -AT-PS/2: Full-Sized Circular DIN
6920-3	1 and/or 2	XT-AT-PS/2 & AT Clones: Mini-DIN
6920-6 †	2 and/or 3	XT-AT-PS/2: Full-Sized Circular DIN
Triple Track		
Model #	Mag Tracks	Host Interface: Connector Compatibility
6920-5	1, 2 and/or 3 ‡	XT-AT-PS/2 & AT Clones: Mini-DIN

† Not standard product. Please consult factory for availability.

‡ Triple track – any combination.



---

## Installation

All SCANTEAM 6920 MSRs are shipped with the configuration set to AT type keyboard scan codes, and set to allow the MSR to auto-detect the state of the “Caps Lock” key on the host PC.

The SCANTEAM 6920 draws all power from its keyboard interface cables, and thus does not require an external power pack.

The SCANTEAM 6920 is easily installed into a PC system in the following steps:

- 1) Turn the system power off.
- 2) Unplug the PC keyboard’s connector from PC’s rear panel connector port.
- 3) Plug the keyboard’s connector into one of the MSR’s pigtail connectors.
- 4) Connect the other MSR pigtail connector into the keyboard port on the PC’s rear panel
- 5) Turn the system power on.
- 6) Test the SCANTEAM 6920’s host interface configuration by passing a magnetic stripe card through the SCANTEAM 6920. The magnetic stripe data should appear on your PC screen as if you had typed it into the PC. If the data does not appear on the screen, you may have to modify the output data configuration of the SCANTEAM 6920 (see page 6, Configuration Options).

**Caution:** Always turn power to the host PC off before connecting, disconnecting, and/or changing DIP switch settings.

---

## Output Data Format

**Note:** See *DIP Switch Feature Selection chart on page 8 for factory default settings.*

### Single Track:

{PREFIX} {SS} <CARD DATA> {ES} {SUFFIX} {CARRIAGE RETURN}

### Dual Track:

Track 2 data follows track 1 data **or** precedes track 3 data.

{PREFIX} {SS} <TRACK 1 **or** TRACK 2 DATA> {ES} {SUFFIX} {CARRIAGE RETURN}

{PREFIX} {SS} <TRACK 2 **or** TRACK 3 DATA> {ES} {SUFFIX} {CARRIAGE RETURN}

### Triple Track:

Track 1 data followed by track 2 data, and then track 3 data.

{PREFIX} {SS} <TRACK 1 DATA> {ES} {SUFFIX} {CARRIAGE RETURN}

{PREFIX} {SS} <TRACK 2 DATA> {ES} {SUFFIX} {CARRIAGE RETURN}

{PREFIX} {SS} <TRACK 3 DATA> {ES} {SUFFIX} {CARRIAGE RETURN}

**Where:** SS = Start sentinel      %    Track 1 for ISO, CA DMV, AAMVA  
  ;    Track 2 for ISO, CA DMV, AAMVA  
  ;    Track 3 for ISO  
  %    Track 3 for AAMVA  
  !    Track 3 for CA DMV  
  ?    Tracks 1, 2, 3 for ISO, CA DMV, AAMVA  
  ES = End sentinel

ISO = International Standards Organization (ISO # 7811)

CA DMV = California Department of Motor Vehicles

AAMVA = American Association of Motor Vehicle Administrators

*Data characters in braces, “{ },” and not in boldface are optional.*

---

## Configuration Options: Dip Switch Controlled

The SCANTEAM 6920 contains a Dual In-Line Package (DIP) switch pack which is used to configure the operation of the reader. The position of these switches are pre-set by Welch Allyn, and normally do not need to be changed by the user. It is only when the SCANTEAM 6920 is attached to certain XT-AT-PS/2 clones that you may need to change these settings.

The DIP switches on the SCANTEAM 6920 control the following host interface parameters:

### **“SS” and “ES” characters**

This parameter allows the “SS” and “ES” characters encoded on the magnetic stripe to be transmitted or not transmitted to the host PC.

### **Carriage Return (CR)**

This parameter allows transmission of a CR character (or no CR) after each track or *all* tracks of data sent by the MSR.

### **Host Keyboard Scan Code Selection**

This parameter allows the 6920 to be set to output either “XT” type keyboard scan codes or “AT” type keyboard scan codes.

### **Keyboard Speed**

This parameter allows the scan code transmission speed to be set at either 25 or 80 characters per second (C/S). Many early PCs and PC clones cannot support 80 C/S scan code speeds and must be set to 25 C/S.

### **Upper / Lower Case**

The data encoded on the magnetic stripe usually contains only upper case characters. If the host PC's “Caps Lock” key is set, the host PC will misinterpret the data from the 6920 as lower case. A DIP switch setting allows the 6920 to sense the state of the Caps Lock key and automatically transmit the data such that the host PC always receives upper case characters.

In order to access the DIP switch pack, the DIP switch cover must be removed, exposing the switches.

**Caution:** Always turn power to the host PC off before connecting, disconnecting, and/or changing DIP switch settings.

---

### Accessing the SCANTEAM 6920 DIP Switch

1. Remove the DIP switch cover (on the bottom of the MSR).

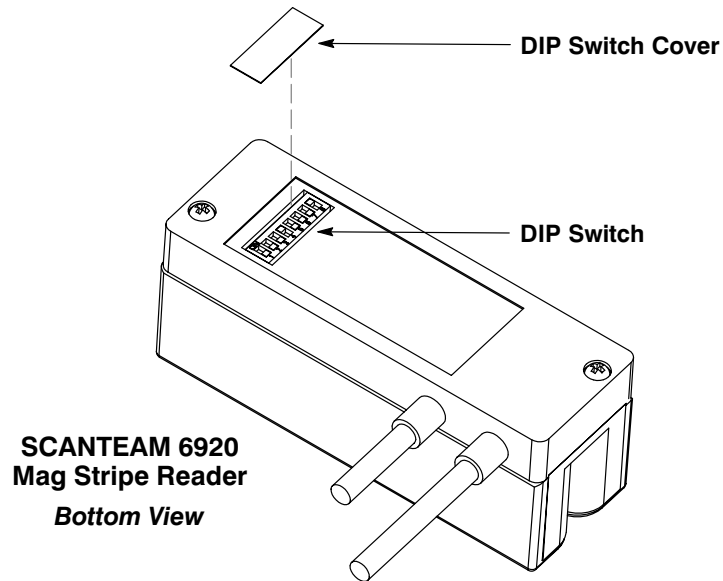

2. Set DIP switches to desired position.

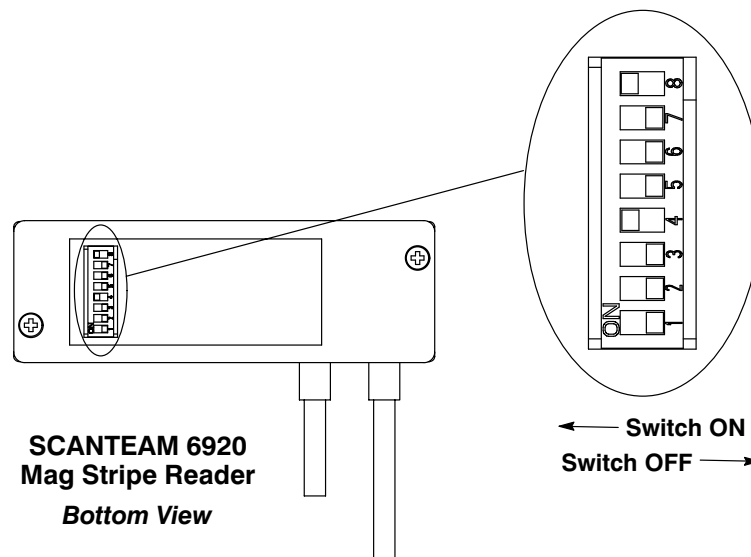

3. Re-install the DIP switch cover.

## Dip Switch Feature Selection

Parameter	Configurations				
Lower & Upper Case Control	<b>Setting SW 1</b>	Always Upper Case OFF*		Keyboard Control ON	
Keyboard Type	<b>Setting SW 2</b>	AT OFF* ②		XT-PS/2 models 25/30/70 ON ③ ④ ⑤	
SS, ES Code	<b>Setting SW 3</b>	Enabled OFF*		Disabled ON	
Carriage Return Setting	<b>Setting SW 4</b>	CR None ON	After All Tracks OFF	After Each Track ON*	Reserved OFF
	<b>Setting SW 5</b>	ON	ON	OFF*	OFF
Keystroke Speed <i>Characters per second</i>	<b>Setting SW 6</b>	80 C/S OFF*		25 C/S ON ⑤	
Output Type (Factory Set)	<b>Setting SW 7</b>	Reserved OFF*			
Mode ⑥	<b>Setting SW 8</b>	Normal Operating ON*		Keyboard Programming OFF	

- Notes:**
- ① Asterisk (\*) Indicates Factory Default Setting.
  - ② Use this configuration if your PS/2 uses AT type keyboard scan codes.
  - ③ When using XT Mode, SW 1 must be set ON.
  - ④ This DIP switch setting value can be changed in Keyboard Programming Mode. See "Using Keyboard Programming Mode to Set Keyboard Type," page 10.
  - ⑤ This DIP switch setting value can be changed in Keyboard Programming Mode. See "Using Keyboard Programming Mode to Set Keystroke Speed," page 9.
  - ⑥ See page 9 for information about using the "Keyboard Programming" Mode switch (SW8).

---

## Configuration Options: Keyboard Programming Mode

The SCANTEAM 6920 Magnetic Stripe Reader has two operating modes: Normal Operation and Keyboard Programming.

In Normal Operation mode, everything typed on a connected keyboard is passed to the host PC directly. In Keyboard Programming mode, the MSR monitors the key pressed and programs the MSR depending on the keystrokes. The green LED will flash and the MSR will beep as each command key is typed during programming.

In Keyboard Programming mode, the following parameters are programmable:

- keystroke speed
- transmit control character
- suffix character selection
- MSR track enable/disable
- keyboard type
- prefix character selection
- beeper enable/disable
- return to default settings

The SCANTEAM 6920 detects the operating mode only when power to the computer is turned on. To enter Keyboard Programming mode, turn the host PC off, set switch 8 to the OFF position, and then restore power to the computer.

**Note:** *To set options in the "Keyboard Programming" mode all commands MUST BE typed in with an AT type keyboard.*

### Setting Keystroke Speed to 80 Characters per Second

1. Turn off power to the host PC.
2. Set MSR DIP switch position 8 to OFF.
3. Turn on power to the host PC.
4. Type the following keys: **US8<ENTER>**.
5. Turn off power to the host PC.
6. Set MSR DIP switch position 8 to ON.
7. Set MSR DIP switch position 6 to ON.
8. Reapply power to the host PC.

---

### Setting Keystroke Speed to 25, 40, or 60 Characters per Second

Use the same procedure as “setting keystroke speed to 80 c/s” to set the characters per second to 25, 40, or 60. The keystrokes (at step 4) are:

**US2<ENTER>** for 25 C/S or

**US4<ENTER>** for 40 C/S or

**US6<ENTER>** for 60 C/S.

### Setting Keyboard Type to XT

1. Turn off power to the host PC.
2. Set MSR DIP switch position 8 to OFF.
3. Turn on power to the host PC.
4. Type the following keys: **UKX<ENTER>**.
5. Turn off power to the host PC.
6. Set MSR DIP switch position 8 to ON.
7. Set MSR DIP switch position 2 to ON.

**Note:** Step 8 is required for XT keyboard type command (“UKX”) **only!**

8. Set MSR DIP switch position 1 to ON.
9. Reapply power to the host PC.

### Setting Keyboard Type to PS/2 models 25/30/70 or AT-PS/2

Use the same procedure (above) to change from AT-PS/2 to PS/2 models 25/30/70 type keyboards, or from XT to AT-PS/2. The keystrokes (at step 4) are:

**UKP<ENTER>** to change to PS/2 models 25/30/70 or

**UKA<ENTER>** to change to AT-PS/2.

---

### Setting and Activating a Transmit Control Character

Some applications may require data from the MSR *not* be transmitted automatically after each card swipe. Use this programming feature to set a keyboard character that, when pressed, will transmit MSR data to the host PC.

1. Turn off power to the host PC.
2. Set MSR DIP switch position 8 to OFF.
3. Turn on power to the host PC.
4. Type the following keys: **UAE $x$ <ENTER>**  
– where “ $x$ ” is:
  - any lower case letter (a to z),
  - any number (0 to 9),
  - any Function key (F1 through F12), or
  - the ESC, SPACE, [, ], or TAB keys.
5. Turn off power to the host PC.
6. Set MSR DIP switch position 8 to ON.
7. Reapply power to the host PC.

### Deactivating and Eliminating a Transmit Control Character

Use the same procedure (above) to deactivate and eliminate a transmit control character. The keystrokes (at step 4) are:

**UAD<ENTER>**



---

### Setting a Prefix (preamble) Character

1. Turn off power to the host PC.
2. Set MSR DIP switch position 8 to OFF.
3. Turn on power to the host PC.
4. Type the following keys: **UBExxxxxx;<ENTER>**
  - where “x” is:
    - any lower case letter (a to z),
    - any number (0 to 9),
    - any Function key (F1 through F12), or
    - the ESC, SPACE, CR, [, ], or TAB keys.

**Note:** *“.” must be typed after the prefix characters are entered. Up to five prefix characters may be assigned.*

5. Turn off power to the host PC.
6. Set MSR DIP switch position 8 to ON.
7. Reapply power to the host PC.

### Setting a Suffix (postamble) Character

Use the same procedure as “setting a prefix” to activate and set a suffix (postamble). The keystrokes (at step 4) are:

**UEExxxxxx;<ENTER>**

### Setting the Position of a Prefix (preamble) or a Suffix (postamble) in data

Use the same procedure as “setting a prefix” to set the position of a prefix (preamble) or suffix (postamble) in the data sent to the host PC. The keystrokes (at step 4) are:

**UPE<ENTER>** to send the prefix before and the suffix after each track

**UPD<ENTER>** to send the prefix before and the suffix after all tracks.

### Deactivating and Eliminating a Prefix (preamble) or a Suffix (postamble)

Use the same procedure as “setting a prefix” to deactivate and eliminate a prefix (preamble) or suffix (postamble). The keystrokes (at step 4) are:

**UBD<ENTER>** to disable the prefix (preamble) or

**UED<ENTER>** to disable the suffix (postamble).

---

### Enabling or Disabling Track Configurations

1. Turn off power to the host PC.
2. Set MSR DIP switch position 8 to OFF.
3. Turn on power to the host PC.
4. Type the following keys: **UT<sub>x</sub><ENTER>**  
– where “**x**” is the number 1 through 7. The number controls the following:
  - 1 = enable track 1,
  - 2 = enable track 2,
  - 3 = enable track 3,
  - 4 = enable track 1 and 2,
  - 5 = enable track 1 and 3,
  - 6 = enable track 2 and 3,
  - 7 = enable track 1, 2, and 3.
5. Turn off power to the host PC.
6. Set MSR DIP switch position 8 to ON.
7. Reapply power to the host PC.

**Note:** *Triple track enable/disable options are not available with a two track MSR.*

### Returning to Default Settings or Displaying a Summary of Commands

1. Turn off power to the host PC.
2. Set MSR DIP switch position 8 to OFF.
3. Turn on power to the host PC.
4. Type the following keys:  
**UR<ENTER>** to return to default settings, or  
**UL<ENTER>** to display a summary of commands.
5. Turn off power to the host PC.
6. Set MSR DIP switch position 8 to ON.
7. Reapply power to the host PC.

---

### Displaying a Status Check

1. Turn off power to the host PC.
2. Set MSR DIP switch position 8 to OFF.
3. Turn on power to the host PC.
4. Type the following keys: **UD<ENTER>**.
5. Turn off power to the host PC.
6. Set MSR DIP switch position 8 to ON.
7. Reapply power to the host PC.

### Status Check Display Example:

```
rem transmission speed xx char./sec
rem keyboard type xx
rem activation char. disable [or x]
rem track x enable
rem begin key enable. begin keys is x
rem end key enable, end keys is x
rem beeper setup enable
rem prefix / suffix at ...
rem [ur] return to default setup
rem [ul] list how to using function key
```

Status check displays the following information:

Transmission speed xx = current value.

Keyboard type xx = current type.

Activation character disable or x = actual character when enabled.

Track x = current track enabled.

Begin key x = current prefix (preamble), up to five characters.

End key x = current suffix (postamble), up to five characters.

Prefix / Suffix position = before / after all or each track(s).

---

## Specifications

Recording Method	Two-frequency coherent phase (F2F), compatible with ISO 7811
Swipe Speed	5 to 50 in/sec (worst case with $\pm 12\%$ jitter card), bi-directional
Power Requirements	Reader is low-power CMOS. Power is supplied by the computer to operate the reader.
Current Draw	50 mA @ +5 VDC maximum
Output	Data read from magnetic stripe card is transmitted to the computer as though entered at the keyboard. (TTL decoded-out)
Operating Temperatures	14° F to 122° F (-10° C to 50° C)
Storage Temperatures	-22° F to 158° F (-30° C to 70° C)
Operating Humidity	10% to 90% relative humidity
Dimensions	Length 3.94 in (10.0 cm) Width 1.34 in (3.40 cm) Height 1.67 in (4.24 cm)
Weight	Approximately 10.6 oz. (300 g)
Cable Length	From card reader to keyboard, approximately 1 foot (30 cm). From card reader to computer, approximately 5 feet (150 cm).
Connectors	1 foot cable with 5 pin DIN or Mini-DIN type socket, 5 foot cable with 5 pin DIN or Mini-DIN type connector
Magnetic Head Life	300,000 passes minimum (longer life version available)
"Caps Lock" Auto Detect	Automatic detection of the state of the host device's "Caps Lock" key.
Configuration Options	Contains an 8 position DIP switch which allows users to select host interface parameters (see table on page 8) and keyboard commands.

---

## Pin Assignments

### Model 6920–1, –2 † and –6 †

Pin #	Function
1	Data Clock
2	Data from MSR
3	No connection
4	Signal Ground
5	+ 5 VDC power input
Shell	Shield (male and female end)

### Model 6920–3 and –5

Pin #	Function
1	Data from MSR
2	No connection
3	Signal Ground
4	+ 5 VDC power input
5	Data Clock
6	No connection
Shell	Shield

† Not standard product. Please consult factory for availability.

## Software Revision History

The following table contains the SCANTEAM 6920 MSR's software revision history. The software revision of the SCANTEAM 6920 is printed on the label located on the bottom of the MSR.

Software Revision	Effective UG Date/Rev	Notes
All MSRB.HEX, BC25	prior to 5/23/96	Non-CE, With DIP switch track 1 enable/disable.
M200A002.HEX, 6B50	5/23/96 Rev B	CE, Without DIP switch track 1 enable/disable.
M200A004.HEX, D692	9/23/96 Rev D	CE, With programmable track combination enable/disable, Programmable one character prefix/suffix.
M200B014.HEX, 5F2E	1/1/97 Rev E Rev F	Above plus: LED, Programmable beeper enable/disable, Programmable five character prefix/suffix.

---

## Limited Warranty

Welch Allyn warrants its products to be functional and free from manufacturing defects at the time of delivery. Welch Allyn warrants that it will replace or repair, at its option, any SCANTEAM 6920 that fails to perform according to its published specifications during a period of one (1) year from the time of shipment by Welch Allyn (or from a Welch Allyn authorized distributor) to the user.

***Any attempt on the part of the user to disassemble or service the reader will void the warranty.***

The warranty does not apply if, in the sole opinion of Welch Allyn, the reader has been damaged by accident, misuse, neglect, improper shipping and handling. The warranty is valid only if the reader has not been tampered with or serviced by any party unauthorized by Welch Allyn as a repair facility. The responsibility to protect the reader from static damage is solely that of the user.

THE WARRANTIES SET FORTH HEREIN ARE IN LIEU OF ANY AND ALL OTHER WARRANTIES EXPRESSED OR IMPLIED INCLUDING THE WARRANTIES OF MERCHANTABILITY AND FITNESS FOR A PARTICULAR PURPOSE. THE BUYER ACKNOWLEDGES THAT NO OTHER REPRESENTATIONS WERE MADE OR RELIED UPON WITH RESPECT TO THE QUALITY AND FUNCTION OF THE PRODUCT HEREIN SOLD.

IN NO EVENT SHALL WELCH ALLYN OR ITS RESELLERS BE LIABLE FOR ANY LOSS, INCONVENIENCE OR DAMAGE WHETHER DIRECT, INCIDENTAL, CONSEQUENTIAL OR OTHERWISE, AND WHETHER CAUSED BY NEGLIGENCE OR OTHER FAULT RESULTING FROM THE BREACH OF ANY EXPRESS WARRANTY EXCEPT AS SET FORTH HEREIN. SOME STATES DO NOT ALLOW THE EXCLUSION OR LIMITATION OF INCIDENTAL OR CONSEQUENTIAL DAMAGES, SO THE ABOVE LIMITATIONS OR EXCLUSIONS MAY NOT APPLY TO YOU.

***This warranty gives you specific legal rights and you may also have other rights which vary from state to state or country to country.***



6920/UG            Rev F  
*S/W: M200B014.HEX, 5F2E*