

## DESCRIPTION

3.9" small aperture fixed position round recessed wall wash trim.  
For use with 12V MR16 lamp 50W max., \*CMHMR16 20W, or \*ES16 BriteSpot 39W.

For use in wall washing applications where small aperture, recessed ceiling fixtures are desired.

<b>Catalog #</b>		<b>Type</b>
<b>Project</b>		
<b>Comments</b>		<b>Date</b>
<b>Prepared by</b>		

## SPECIFICATION FEATURES

### A...Recessed Trim

Fixed position wall wash trim. 3.9" o.d. trim face with 1.7" aperture. Includes bullet plunger retainers for smooth snap-in action during installation and removal of trim for relamping. Helps guard against plaster cracking.

### B...Lamp

For use with 12V MR16 lamp 50W max.  
\*CMH MR16 20W or \*ES16 BriteSpot 39W.  
Lamp not included.

### C...Socket

Posi-Grip bi-pin socket for 12V MR16. GX10 for metal halide lamps. (Included with Mini Accurus Housing sold separately)

### D...Lens

Frosted lens included. Can hold up to two (2) optical accessories total.

### E...Reflector

Includes internal "kicker" reflector for optimized light output.

### F...Finish

Trim face is powder coated in white, black, industrial silver, stainless steel or primer finish for painting in existing ceiling color. All other internal components are flat black.

### G...Safety

Steel safety cable provided. Attaches to tab inside housing to prevent falling during maintenance or as a result of accidental dislodging of the trim.

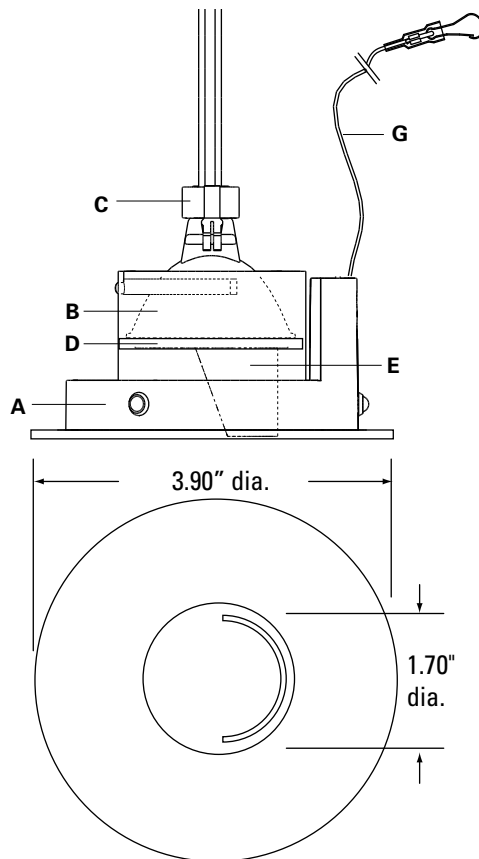

## MINI ACCURUS RECESSED

### ACM5002 3.9" O.D. 1.7" Aperture Round Fixed Wall Wash Trim

FOR 12V MR16 50W max.  
\*CMH MR16 20W  
\*ES16 BriteSpot 39W

Compatible Housings:

ACM500 / ACM500MH

ACM502IC / ACM502ICMH

ACM504RM / ACM504RMMH



## ORDERING INFORMATION

<b>ACM5002</b>	
<b>Fixture</b> ACM5002 = 3.9" Recessed Fixed Position Round Wall Wash Trim 1.7" Aperture	<b>Finish</b> WH = White BK = Black S = Industrial Silver SS = Stainless Steel (painted) PM = Primer

\* Consult factory for metal halide lamps