



**Repair and Replacement Procedures
Model 5040 A Series**

Consumer Replacement Items



Replacement Parts for 5040 A Series

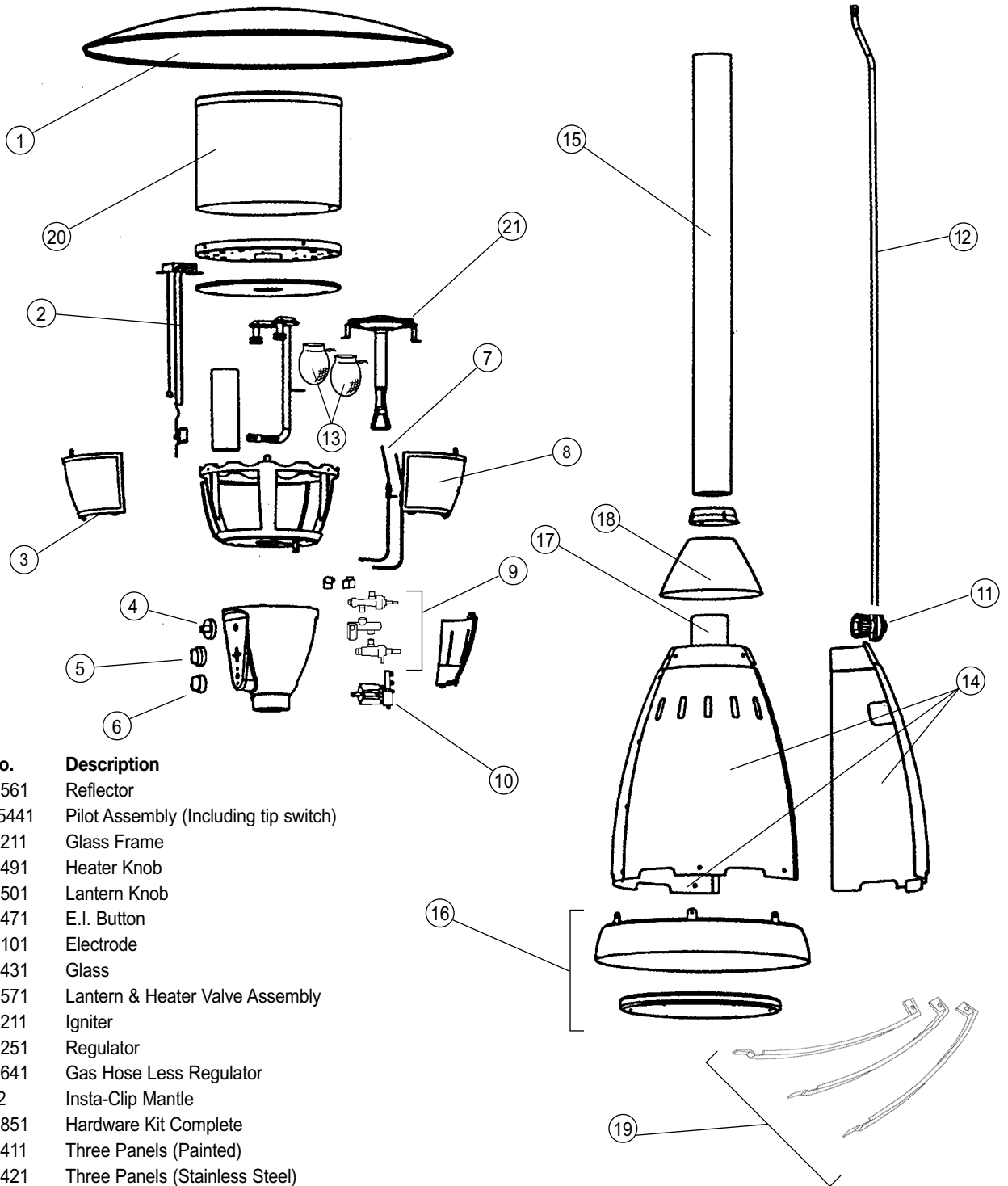

No.	Part No.	Description
1	5040-1561	Reflector
2	5040A5441	Pilot Assembly (Including tip switch)
3	5040-1211	Glass Frame
4	5040-1491	Heater Knob
5	5040-1501	Lantern Knob
6	5040-1471	E.I. Button
7	5040-3101	Electrode
8	5040-1431	Glass
9	5040-5571	Lantern & Heater Valve Assembly
10	5040-2211	Igniter
11	5040-5251	Regulator
12	5040-5641	Gas Hose Less Regulator
13	21A122	Insta-Clip Mantle
	5040-0851	Hardware Kit Complete
14	5040-4411	Three Panels (Painted)
	5040-4421	Three Panels (Stainless Steel)
15	5040-4401	Post (Painted)
	5040-3391	Post (Stainless Steel)
16	5040-1751	Base Assembly
17	5040-4811	Post Mount (Painted)
	5040-4801	Post Mount (Stainless Steel)
18	5040-1251	Post Mount Cover (Painted)
	5040-1261	Post Mount Cover (Stainless Steel)
19	5040-0711	Three Support Brackets (Painted)
	5040-0701	Three Support Brackets (Stainless Steel)
20	5040-1151	Heater Burner Screen
21	5040-1161	Burner

Heater Manual

Table of Contents

For Repair or Replacement of:	<u>Page</u>
Reflector	4
Burner Screen	4
Burner	5
Mantle Electrodes	5
Knob(s) or Igniter	6
Burner Caps	7
Pilot/Burner Electrode	7
Tip Switch	
Mantle Section	
Gas Tips, Burner Gas Line	
Valve(s) and/or Valve Manifold	
Troubleshooting	8-11

© 2003 The Coleman Company, Inc.
3600 North Hydraulic, Wichita, KS 67219 U.S.A.
1-800-835-3278 or TDD 316-832-8707
Coleman® and  are registered trademarks
of The Coleman Company, Inc.



Caution: After completion of repairs and before operating the patio heater, make sure you read and follow all safety information in the Instructions for Use manual. If you do not have this manual, contact Coleman at 1-800-835-3278 or TDD 316-832-8707.

To repair or replace reflector, refer to **Figure 1**.

Remove four hex-head screws holding reflector to burner head using a 11/32" wrench (Figure 1). Also see Note #1.

To repair or replace burner screen, refer to **Figures 1-5**. To avoid cuts, do not run fingers or hands along edges of thin sheet-metal parts.

Remove reflector (Figure 1). Remove 4 lower hex-head screws holding burner screen to burner screen assembly bottom using a 7/16" wrench (Figure 2). Lift burner screen assembly top from heater head (Figure 3). Also see Note #1. Remove 4 upper hex-head screws holding burner screen to burner screen assembly top using a 7/16" wrench (Figure 4). Finally, remove burner screen assembly top (Figure 5). **Reassembly caution:** Edge of screen with holes closer to the edge goes "up" on re-assembly (attached to screen assembly top). When reinstalling **burner screen** make sure that the **oval hole** at the bottom edge of the **burner screen** (Figure 3-a) is lined up with the hole in the **burner screen bottom**, marked **Pilot Port** (Figure 3-b).



Figure 1



Figure 2



Figure 3

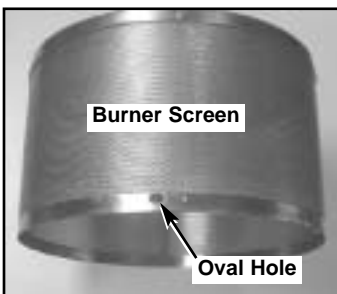

Figure 3-a

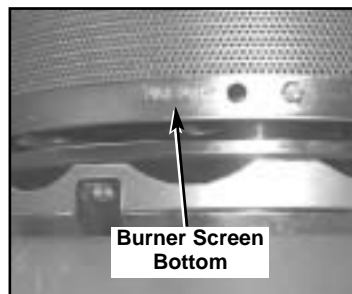

Figure 3-b



Figure 4

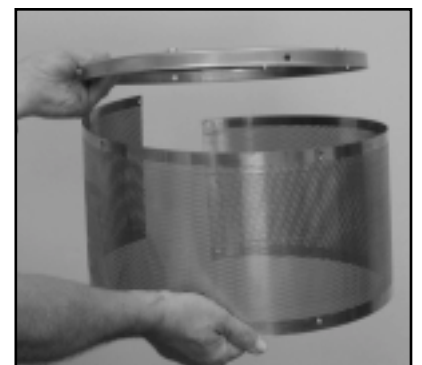

Figure 5

To repair or replace the burner, refer to Figures 1-3, and Figures 6-7.

Remove reflector (Figure 1). Remove burner screen assembly top as a unit by removing only the 4 lower hex-head screws holding the burner screen assembly top to its bottom using a 7/16" wrench (Figures 2 and 3). Remove 2 burner bracket screws (Figure 6-a). Also see Note #1. Then lift burner straight up to remove (Figure 7). When reinstalling the **burner** it may help to rotate it as it is pushed down the center tube. Make sure the **burner locating hole** at the bottom of the **burner** (Figure 6) fits over the **valve/manifold boss**. This can be verified by looking through the maintenance access opening (Figure 7-a).

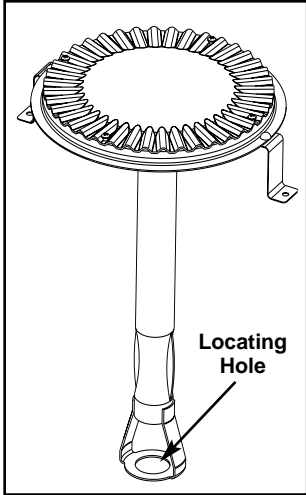

Figure 6



Figure 6-a

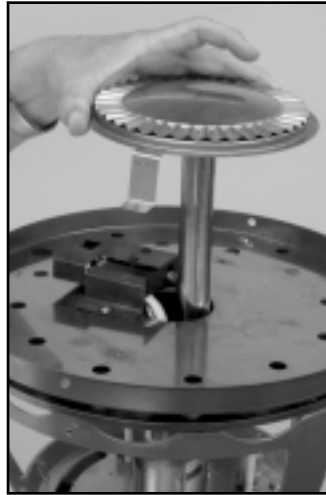

Figure 7

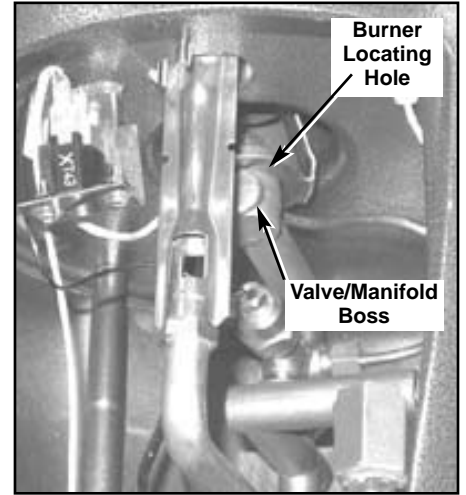

Figure 7-a

To replace mantle electrode(s), refer to Figures 8-11.

Remove glass panels. Unplug electrode wire from igniter (Figure 9). Then remove electrode bracket screw (Figure 10). Electrode can now be removed through the opening in the head frame (Figure 11). Also see Note #1.

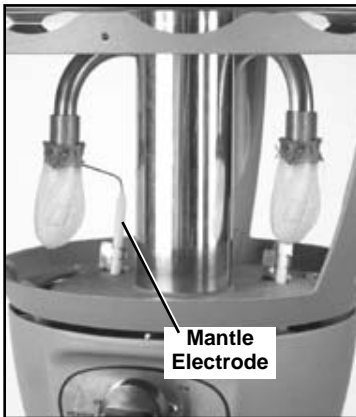

Figure 8



Figure 9



Figure 10

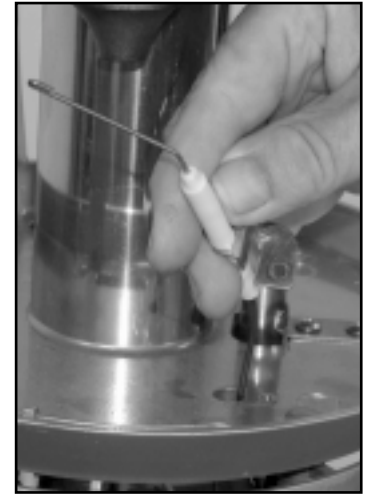

Figure 11

Note #1: For difficult to remove screws, apply 3-in-1 oil, penetrating oil, or WD-40. Let sit for several hours or overnight, then attempt to remove screws again.

To replace knob(s), refer to Figure 12.

Note: Knobs are a friction fit. To remove pull straight out on knob (Figure 12). When replacing knob, flat side of knob hole must match flat on shaft that extends from the control console.

To replace igniter, refer to Figures 9 and 13-14.

Remove 3 electrode wires from igniter (Figures 9 & 14). Remove igniter cap and battery (Figure 13). Remove ribbed collar (Figure 13A). Now remove igniter through the maintenance port opening (Figure 14A).



Figure 12



Figure 12A



Figure 13



Figure 13A



Figure 14



Figure 14A

To replace burner caps, refer to Figure 15.

Using a pair of pliers unscrew each burner cap as shown (Figure 15). When reinstalling burner caps apply antiseize compound to the threads to make future removal easier.



Figure 15

To repair or replace pilot/burner electrode assembly (including thermocouple), return heater head to Service Center.

Keep glass, reflector, post, and base. Ship only your Parasol Head to the Service Center.

To replace tip switch, return heater head to Service Center.

Keep glass, reflector, post, and base. Ship only your Parasol Head to the Service Center.

To repair or replace mantle section burner tube/venturi assembly, return heater head to Service Center.

Keep glass, reflector, post, and base. Ship only your Parasol Head to the Service Center.

To repair or replace gas tips, burner gas line, valve(s), valve manifold and/or hose, return heater head to Service Center.

Keep glass, reflector, post, and base. Ship only your Parasol Head to the Service Center.



Caution: After completion of any repairs and before operating your Parasol Heater, make sure you read and follow all safety information in the Instructions for Use manual. If you do not have this manual, contact Coleman Consumer Service at 1-800-835-3278 or TDD 316-832-8707.

A. BASE, SHEET METAL, & POST COMPONENTS:

Problem	Solution	Comments
1. My heater is “wobbly”	Tighten all screws, including those under the post mount cover. Replace any missing screws. Be careful not to overtighten screws, which may result in stripped threads.	It is possible to drill out any holes with stripped threads, and tap for use with the next size screw.
2. During assembly some holes do not completely line up.	During assembly leave all screws loose until all screws are in place. Then tighten. If you need just a little more clearance in a non-threaded hole, use a small, round file to open up the hole a little. Do not file or drill out threaded holes (the only exception is item A-1, “comments”).	
3. The three small holes, spaced at 120 degrees each, at the end of the post do not match up with the holes in the post mount.	Post is upside down! The three small holes at 120 degrees spacing should match up with the three threaded holes (tapped for 10-24 threads) in the lower (small end) portion of the heater head.	The post mount holes are tapped for 1/4"-20 threads.
4. Cannot remove the screws that hold the reflector to the heater head. Cannot remove screws that hold burner screen to burner screen base (or burner screen top). Cannot remove the screws that hold the burner assembly to the burner screen base. Cannot remove the screws that hold pilot/electrode assembly to the burner screen base.	After letting the heater cool down for a while, apply penetrating oil, kerosene, or WD-40 to the perimeter of each screw and let soak for several hours or overnight.	A screwdriver with a tip that is a good fit to the screw head must be used. To insure future ease of removal, use antiseize compound on all screw threads that are subjected to high heat.
5. I need to send my heater head out for repair, but I can not get the hose/regulator assembly up through the post.	The regulator must be unscrewed from the hose assembly in order to completely remove the heater head from the Parasol Heater post.	

B. ROTARY and BATTERY-OPERATED IGNITERS:

Problem	Solution	Comments
<p>1. Rotary igniter is loose.</p> <p>Battery-operated igniter is loose.</p>	<p>Pull igniter knob off (ref. Figures 12 & 12A in 5040 Series Repair and Replacement Procedures) and tighten the mounting screws.</p> <p>Make sure that the ribbed plastic collar that holds the battery-operated igniter to the control console is tight (ref. Figure 13). This will insure that a grounding tab (not visible) is making good contact.</p>	
<p>2. No spark is visible at electrodes when rotary igniter is rotated (or when battery-operated igniter is actuated – 5040A models only)</p> <p>No “zap-zap-zap” is heard when button on battery-operated igniter is pressed.</p>	<p>The spark may be very difficult to see in daylight, but should be visible at night.</p> <p>If mantle section or heater section will not light using the igniter, check to see if electrode wires are firmly attached to the rear of the igniter (ref. Figure 14).</p> <p>Verify that electrode gap is no more than 1/8" – 3/16" inch from the burner cap.</p> <p>On battery operated igniters try installing a new battery. Make sure that the ribbed plastic collar that holds the battery operated igniter to the control console is tight (ref. Figure 13 of the 5040A Series Repair and Replacement Procedures). This will insure that a grounding tab (not visible) is making good contact.</p> <p>Replace battery.</p>	<p>No cause for concern exists when spark is not visible providing mantle and heater sections light properly.</p> <p>The mantle section on all models can be lighted using a match if the igniter is not working properly.</p> <p>The heater section on “A” model Parasol Heaters can be lighted with a long fireplace match through the pilot port hole in the burner screen if the igniter is not working.</p>
<p>3. Mantle electrode is loose so spark gap varies.</p>	<p>Check to see if electrode bracket screw is loose. If so tighten screw. If ceramic is loose in bracket, it may be possible to tighten it using pliers or a vise. If ceramic is cracked, replace with a new mantle electrode assembly.</p>	<p>If a spark appears anywhere along the length of the ceramic, this is an indication that the ceramic is cracked and should be replaced with a new electrode assembly.</p>

C. MANTLE (LIGHT) SECTION:

Problem	Solution	Comments
<p>1. New mantles will not light using the igniter.</p> <p>Mantles will not light using a match.</p>	<p>After tying new mantles to the burner caps, they should be burned off using a match before use. The gas controls should be "off". After "burn-off" it is suggested that you light them the first time using a match. Once lighted, they will fill out a bit, then should relight O.K. using the igniter.</p> <p>Make sure your propane tank is not empty and that the propane tank valve and heater's mantle section valve are both turned "on".</p> <p>Regulator pressure setting may be too low. Replace regulator.</p> <p>If all the above have been ruled out, then the mantle gas tip may be restricted. Replace mantle gas tip. Contact Coleman Customer Service (1-800-835-3278).</p>	<p>Note: When a new tank has just been installed there will be a delay while the propane flows up the hose to the mantles.</p>
<p>2. New mantles are dim after being lighted.</p>	<p>Make sure that item C-1 has been observed. Make sure that the string (or wire clip on Insta-light mantles) is located in the burner cap groove. If the mantle is tied higher up on the burner cap, light output will be less than normal.</p> <p>Sometimes spiders leave webs inside the burner/venturi tube(s), causing problems. A Q-tip can be used to clean out the burner caps and burner tubes on "dash" model Parasol Heaters. On "A" models the burner caps will first need to be removed then the burner tube can be cleaned out using a Q-tip. Compressed air blown up through the burner caps may also help. This may be necessary to reach the venturi portion of the assembly.</p> <p>The regulator pressure setting may be too low. Replace regulator.</p>	<p>Mantles with holes or tears will not work properly and should be replaced.</p>
<p>3. New mantles are dim after being lighted or go out or become dim when lighting of the burner section is attempted.</p>	<p>Regulator pressure setting problem. Replace regulator.</p>	

D. HEATER (BURNER) SECTION:

Problem	Solution	Comments
<p>1. Pilot will not light using the igniter (or with a long match – “A” models only).</p>	<p>Make sure propane tank is not empty and that propane tank valve and heater valve are both turned “on”.</p> <p>Note: Valve must be in “pilot” position and must be pressed “in” while igniter is actuated, otherwise pilot will not light. After pilot lights you must hold the knob “in” for up to 45 seconds in order to engage the thermocouple. Then the knob may be released and rotated “full on” to light the heater burner.</p> <p>If igniter wire to pilot/electrode assembly is loose (or is not connected), then pilot will not light using igniter. Wire must be reconnected or replaced if damaged. Contact Coleman Customer Service (1-800-835-3278).</p> <p>Pilot air port may be restricted or partially restricted. Blockage will need to be removed. Contact Coleman Customer Service (1-800-835-3278).</p>	<p>Note: When a new tank has just been installed there will be a delay while the propane fills the hose as it flows up to the pilot.</p> <p>Make sure all wires that attach to the back of the igniter are firmly in place.</p> <p>If spark gap at electrode is too wide, hard lighting or no lighting may result. Contact Coleman Customer Service (1-800-835-3278).</p>
<p>2. Pilot flame is long and yellow (and main burner is not yet on).</p>	<p>Pilot air port may be restricted. Blockage will need to be removed. Contact Coleman Customer Service (1-800-835-3278).</p>	<p>Note: It is normal for the pilot flame length to increase when the main burner is on.</p>
<p>3. Burner lights, but flame is irregular and seems to burn around only part of the burner’s periphery.</p>	<p>Some of the spot welds holding the burner assembly together may have failed. Replace burner assembly.</p>	
<p>4. Pilot lights, but burner will not light.</p>	<p>Main burner gas tip may be restricted. Replace main burner gas tip. Contact Coleman Customer Service (1-800-835-3278).</p>	