

**TEC**

TEC Bar Code Printer

# **B-30 SERIES**

## **Owner's Manual**

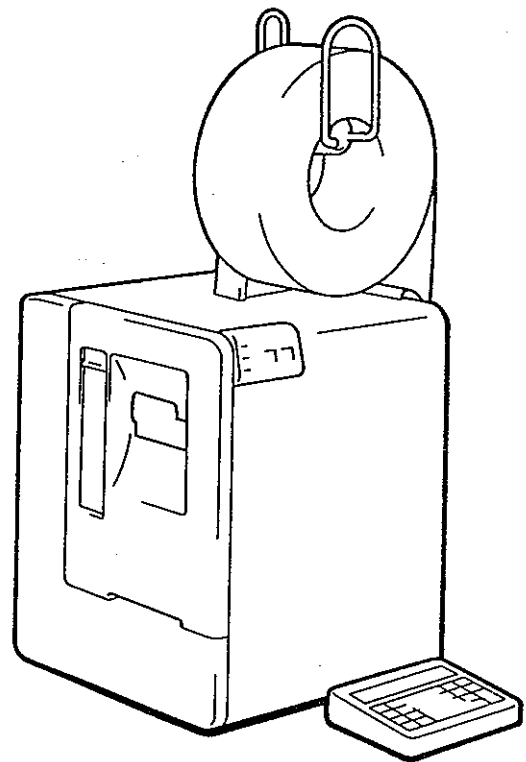

**TOSHIBA TEC CORPORATION**

**WARNING**

This equipment generates, uses, and can radiate radio frequency energy and if not installed and used in accordance with the instruction manual, may cause interference to radio communications. It has been tested and found to comply with the limits for a Class A computing device pursuant to Subpart J of Part 15 of FCC Rules, which are designed to provide reasonable protection against such interference when operated in a commercial environment. Operation of this equipment in a residential area is likely to cause interference in which case the user at his own expense will be required to take whatever measures may be required to correct the interference.

(for U.S.A. only)

**WARNING**

"THIS DIGITAL APPARATUS DOES NOT EXCEED THE CLASS A LIMITS FOR RADIO NOISE EMISSIONS FROM DIGITAL APPARATUS SET OUT IN THE RADIO INTERFERENCE REGULATIONS OF THE CANADIAN DEPARTMENT OF COMMUNICATIONS."

"LE PRÉSENT APPAREIL NUMÉRIQUE N'EMET PAS DE BRUITS RADIOÉLECTRIQUES DÉPASSANT LES LIMITES APPLICABLES AUX APPAREILS NUMÉRIQUES DE LA CLASSE A PRESCRITES DANS LE RÉGLEMENT SUR LE BROUILLAGE RADIOÉLECTRIQUE ÉDICTÉ PAR LE MINISTÈRE DES COMMUNICATIONS DU CANADA."

(for CANADA only)

## INTRODUCTION

Thank you for choosing the TEC Bar Code Printer B-30-AS3. The B-30-AS3 has been developed for issuing various kinds of bar codes, and can be connected to a personal computer, etc., via a TEC interface. The B-30-AS3 adopts a state of the art thermal printer so that it produces less noise and more clearly printed characters. You can easily select either the thermal transfer or thermal direct printing method.

This manual contains information about the general set-up and maintenance of the B-30-AS3 printer, and should be read carefully to obtain maximum performance from your printer. Since ample consideration has been given to safety, there is no danger of damaging the printer by erroneous operation.

Should you have any questions concerning the printer, please refer to this manual. Be sure to keep this manual for future reference.

## PRECAUTIONS

1. Clean the cover by wiping with a dry cloth or a cloth soaked with detergent and thoroughly wrung out. NEVER USE THINNER OR OTHER VOLATILE SOLVENT for cleaning.
2. DO NOT POUR WATER directly on the printer.
3. When in use, avoid locations subject to vibration and direct sunlight.
4. Properly use the TEC-specified label, tag, and ribbon.
5. DO NOT STORE the labels, tags, and ribbons in locations exposed to direct sunlight, high temperature, high humidity, dust, or gas.
6. Place the printer on a level surface.

## CONTENTS

CHAPTER 1	SPECIFICATIONS
CHAPTER 2	BEFORE STARTING UP
CHAPTER 3	INSTALLING THE PRINTER
CHAPTER 4	OPERATION
CHAPTER 5	MAINTENANCE

## APPLICABLE MODEL

B-30-S1-EU, UK, US, EU P, UK P, US P  
 B-30-H1-EU, UK, US, EU P, UK P, US P  
 B-30-C1-EU, UK, US, EU P, UK P, US P  
 B-30-S2-EU, UK, MA, EU P, UK P  
 B-30-H2-EU, UK, MA, EU P, UK P  
 B-30-C2-EU, UK, MA, EU P, UK P  
 B-30-S3-US P, AU P, UK P  
 B-30-H3-AU P  
 B-30-C3-AU P  
 B-30-AS2-US P  
 B-30-AS3-EU, UK, MA, EU P, US P  
 B-30-AH3-EU  
 B-30-S5-US P  
 B-30-AS5-US P  
 B-30-DS2-UK P

# CHAPTER 1

## SPECIFICATIONS

1. PRINTER.....	1- 1
2. SUPPLIES.....	1- 9
3. RIBBON.....	1- 9
4. DIMENSIONS.....	1-10
5. ACCESSORIES.....	1-10

## 1. PRINTER

## ● B-30-S1/H1/C1

Item	Type	B-30-S1	B-30-S1 P	B-30-H1	B-30-H1 P	B-30-C1	B-30-C1 P
Power Requirement		AC 120V $\pm$ 10%, 60Hz . . . for US version AC 220V $\pm$ 10%, 50Hz . . . for EU version AC 240V $\pm$ 10%, 50Hz . . . for UK version					
Current Consumption		220W Max. (Standby: 35W)					
Temperature Limits		5°C to 40°C (41°F to 104°F)					
Relative Humidity		25% to 85% RH (no condensation)					
Print Head		Thermal Print Head at 76.2 mm (3 inches) wide, 7.6 dots per mm (193 dots per inch)					
Printing Method		Thermal Transfer or Thermal Direct					
Print Speed		50 mm (2 inches) per sec., 75 mm (3 inches) per sec., 100 mm (4 inches) per sec.					
Available Printing Width		75.8 mm (2.98 inches) Max.					
Bar Code Format		EAN, UPC, ITF, Code 39, Code 93, Code 128, NW-7					
Type Fonts		Standard font, Bold Face font, Reduced font, OCR-MA, OCR-B					
Rotation		0°, 90°, 180°, 270°					
Issue Method		Batch		Batch or On-demand		Auto cut	
Weight		17 kg (37.5 lbs)				19 kg (41.9 lbs)	
Memory Card Interface		1 slot (for 32 KB SRAM card)					
Serial Interface (RS-232C)		○	○	○	○	○	○
Centronics Interface		△	○	△	○	△	○
Rewinder B-1103		△	△	△	△	—	—
Rewinder B-1103R		△	△	△	△	—	—
Stacker B-1403		—	—	—	—	△	△

○: Standard    △: Option

## ● B-30-S2/H2/C2 (EU, UK version only)

Item	Type	B-30-S2	B-30-S2 P	B-30-H2	B-30-H2 P	B-30-C2	B-30-C2 P
Power Requirement		AC 220V $\pm$ 10%, 50Hz . . . for EU version AC 240V $\pm$ 10%, 50Hz . . . for UK version					
Current Consumption		220W Max. (Standby: 35W)					
Temperature Limits		5°C to 40°C (41°F to 104°F)					
Relative Humidity		25% to 85% RH (no condensation)					
Print Head		Thermal Print Head at 76.2 mm (3 inches) wide, 7.6 dots per mm (193 dots per inch)					
Printing Method		Thermal Transfer or Thermal Direct					
Print Speed		50 mm (2 inches) per sec., 75 mm (3 inches) per sec., 100 mm (4 inches) per sec.					
Available Printing Width		75.8 mm (2.98 inches) Max.					
Bar Code Format		EAN, UPC, ITF, Code 39, Code 93, Code 128, NW-7					
Type Fonts		Standard font, Bold Face font, Reduced font, Outline font, OCR-MA, OCR-B					
Rotation		0°, 90°, 180°, 270°					
Issue Method		Batch		Batch or On-demand		Auto cut	
Weight		17 kg (37.5 lbs)				19 kg (41.9 lbs)	
Memory Card Interface		1 slot (for 32 KB or 64 KB SRAM card)					
Serial Interface (RS-232C)		○	○	○	○	○	○
Centronics Interface		△	○	△	○	△	○
Memory Card MC32-EX		△	△	△	△	△	△
Memory Card MC64-EX		△	△	△	△	△	△
Rewinder B-1103		△	△	△	△	—	—
Rewinder B-1103R		△	△	△	△	—	—
Stacker B-1403		—	—	—	—	△	△

○: Standard    △: Option

## ● B-30-S3/H3/C3 (US, AU version only)

Item	Version	S3-US P	S3-AU P	H3-AU P	C3-AU P
Power Requirement		AC 120V ± 10%, 60Hz	AC240V ± 10%, 50Hz		
Current Consumption		220W Max. (Standby: 35W)			
Temperature Limits		5°C to 40°C (41°F to 104°F)			
Relative Humidity		25% to 85% RH (no condensation)			
Print Head		Thermal Print Head at 76.2 mm (3 inches) wide, 7.6 dots per mm (193 dots per inch)			
Printing Method		Thermal Transfer or Thermal Direct			
Print Speed		50 mm (2 inches) per sec., 75 mm (3 inches) per sec., 100 mm (4 inches) per sec.			
Available Printing Width		75.8 mm (2.98 inches) Max.			
Bar Code Format		EAN, UPC, ITF, Code 39, Code 93, Code 128, NW-7			
Type Fonts		Standard font, Bold Face font, Reduced font, Outline font, OCR-MA, OCR-B			
Rotation		0°, 90°, 180°, 270°			
Issue Method		Batch		Batch or on-demand	Auto cut
Weight		17 kg (37.5 lbs.)			19kg (41.9lbs.)
Memory Card Interface		1 slot (for 32 KB or 64 KB SRAM card)			
Serial Interface (RS-232C)		○	○	○	○
Centronics Interface		○	○	○	○
Memory Card: MC32-EX		△	○	○	○
Memory Card: MC64-EX		△	△	△	△
Keyboard KB-30-NP		△	○	○	○
Rewinder B-1103		△	△	△	-
Rewinder B-1103R		△	△	△	-
Rewinder unit B-1103M		△	△	△	-
Cutter unit B-1203M		△	△	-	○
Stacker B-1403		△	△	-	△

○: Standard    △: Option

## ● B-30-AS2 (US version only)

Item	Model	B-30-AS2-US P
Power Requirement		AC 120V $\pm$ 10%, 60Hz
Current Consumption		220W Max. (Standby: 35W)
Temperature Limits		5°C to 40°C (41°F to 104°F)
Relative Humidity		25% to 85% RH (no condensation)
Print Head		Thermal Print Head at 76.2 mm (3 inches) wide, 10.5 dots per mm (266 dots per inch)
Printing Method		Thermal Transfer or Thermal Direct
Print Speed		50 mm (2 inches) per sec., 75 mm (3 inches) per sec., 100 mm (4 inches) per sec.
Available Printing Width		72.9 mm (2.87 inches) Max.
Bar Code Format		EAN, UPC, ITF, Code 39, Code 93, Code 128, NW-7
Type Fonts		Standard font, Bold Face font, Reduced font, Outline font, OCR-MA, OCR-B
Rotation		0°, 90°, 180°, 270°
Issue Method		Batch
Weight		17 kg (37.5 lbs.)
Interface		Memory Card Interface ..... 1 slot (for 32 KB or 64 KB SRAM card) Serial Interface (RS-232C) Centronics Interface
Option		Memory Card: MC32-EX, MC64-EX Keyboard: KB-30-EX Rewinder: B-1103, B-1103R

## ● B-30-DS2 (UK version only)

Item	Model	B-30-DS2-UK P
Power Requirement		AC 240V $\pm$ 10%, 50Hz
Current Consumption		220W Max. (Standby: 35W)
Temperature Limits		5°C to 40°C (41°F to 104°F)
Relative Humidity		25% to 85% RH (no condensation)
Print Head		Thermal Print Head at 76.2 mm (3 inches) wide, 6 dots per mm (152 dots per inch)
Printing Method		Thermal Transfer or Thermal Direct
Print Speed		50 mm (2 inches) per sec., 75 mm (3 inches) per sec., 100 mm (4 inches) per sec.
Available Printing Width		74.8 mm (2.94 inches) Max.
Bar Code Format		EAN, UPC, ITF, Code 39, Code 93, Code 128, NW-7
Type Fonts		Standard font, Bold Face font, Reduced font, Outline font, OCR-MA, OCR-B
Rotation		0°, 90°, 180°, 270°
Issue Method		Batch
Weight		17 kg (37.5 lbs.)
Interface		Memory Card Interface ..... 1 slot (for 32 KB SRAM card) Serial Interface (RS-232C) Centronics Interface
Memory Card		MC32-EX
Keyboard		KB-30-EX
Option		Rewinder: B-1103, B-1103R



## ● B-30-AS3

Item \ Version	US P	EU	EU P	UK	UK P
Power Requirement	AC 120V $\pm$ 10%, 60Hz	AC 220V $\pm$ 10%, 50Hz		AC 240V $\pm$ 10%, 50Hz	
Current Consumption	220W Max. (Standby: 35W)				
Temperature Limits	5°C to 40°C (41°F to 104°F)				
Relative Humidity	25% to 85% RH (no condensation)				
Print Head	Thermal Print Head at 76.2 mm (3 inches) wide, 10.5 dots per mm (266 dots per inch)				
Printing Method	Thermal Transfer or Thermal Direct				
Print Speed	50 mm (2 inches) per sec., 75 mm (3 inches) per sec., 100 mm (4 inches) per sec.				
Available Printing Width	72.9 mm (2.87 inches) Max.				
Bar Code Format	EAN, UPC, ITF, Code 39, Code 93, Code 128, NW-7				
Type Fonts	Standard font, Bold Face font, Reduced font, Outline font, OCR-MA, OCR-B				
Rotation	0°, 90°, 180°, 270°				
Issue Method	Batch, On-demand (option), or Auto cut (option)				
Weight (approx.)	17 kg (37.5 lbs.)				
Memory Card Interface	1 slot (for 32 KB or 64 KB SRAM card)				
Serial Interface (RS-232C)	○	○	○	○	○
Centronics Interface	○	△	○	△	○
Keyboard KB-30-EX	△	○	○	○	○
Memory Card MC32-EX	△	△	△	△	△
Memory Card MC64-EX	△	△	△	△	△
Rewinder B-1103	△	△	△	△	△
Rewinder B-1103R	△	△	△	△	△
Rewinder unit B-1103M	△	△	△	△	△
Cutter unit B-1203M	△	△	△	△	△
Stacker B-1403	△	△	△	△	△

○: Standard    △: Option

## ● B-30-AH3

Item	Model B-30-AH3-EU
Power Requirement	AC 220V $\pm$ 10%, 50Hz
Current Consumption	220W Max. (Standby: 35W)
Temperature Limits	5°C to 40°C (41°F to 104°F)
Relative Humidity	25% to 85% RH (no condensation)
Print Head	Thermal Print Head at 76.2 mm (3 inches) wide, 10.5 dots per mm (266 dots per inch)
Printing Method	Thermal Transfer or Thermal Direct
Print Speed	50 mm (2 inches) per sec., 75 mm (3 inches) per sec., 100 mm (4 inches) per sec.
Available Printing Width	72.9 mm (2.87 inches) Max.
Bar Code Format	EAN, UPC, ITF, Code 39, Code 93, Code 128, NW-7
Type Fonts	Standard font, Bold Face font, Reduced font, Outline font, OCR-MA, OCR-B
Rotation	0°, 90°, 180°, 270°
Issue Method	On-demand or Batch
Weight	17 kg (37.5 lbs.)
Interface	Memory Card Interface ..... 1 slot (for 32 KB or 64 KB SRAM card)
Option	Serial Interface (RS-232C)
	Centronics Interface
	Memory Card: MC32-EX, MC64-EX
	Keyboard: KB-30-EX
	Rewinder: B-1103, B-1103R

● B-30-S5 (US version only)

Item	Model B-30-S5-US P
Power Requirement	AC 120V $\pm$ 10%, 60Hz
Current Consumption	220W Max. (Standby: 35W)
Temperature Limits	5°C to 40°C (41°F to 104°F)
Relative Humidity	25% to 85% RH (no condensation)
Print Head	Thermal Print Head at 76.2 mm (3 inches) wide, 7.6 dots per mm (193 dots per inch)
Printing Method	Thermal Transfer or Thermal Direct
Print Speed	50 mm (2 inches) per sec., 75 mm (3 inches) per sec., 100 mm (4 inches) per sec.
Available Printing Width	75.8 mm (2.98 inches) Max.
Bar Code Format	EAN, UPC, ITF, Code 39, Code 93, Code 128, NW-7, MSI
Type Fonts	Standard font, Bold Face font, Reduced font, Outline font, OCR-MA, OCR-B
Rotation	0°, 90°, 180°, 270°
Issue Method	Batch, On-demand (option), or Auto cut (option)
Weight	17 kg (37.5 lbs.)
Interface	Memory Card Interface ..... 1 slot (for 32 KB or 64 KB SRAM card) Serial Interface (RS-232C) Centronics Interface
Option	Memory Card: MC32-EX, MC64-EX Keyboard: KB-30-EX Rewinder: B-1103, B-1103R Rewinder unit: B-1103M Cutter unit: B-1203M Stacker: B-1403

## ● B-30-AS5 (US version only)

Item	Model B-30-AS5-US P
Power Requirement	AC 120V ± 10%, 60Hz
Current Consumption	220W Max. (Standby: 35W)
Temperature Limits	5°C to 40°C (41°F to 104°F)
Relative Humidity	25% to 85% RH (no condensation)
Print Head	Thermal Print Head at 76.2 mm (3 inches) wide, 10.5 dots per mm (266 dots per inch)
Printing Method	Thermal Transfer or Thermal Direct
Print Speed	50 mm (2 inches) per sec., 75 mm (3 inches) per sec., 100 mm (4 inches) per sec.
Available Printing Width	72.9 mm (2.87 inches) Max.
Bar Code Format	EAN, UPC, ITF, Code 39, Code 93, Code 128, NW-7, MSI
Type Fonts	Standard font, Bold Face font, Reduced font, Outline font, OCR-MA, OCR-B
Rotation	0°, 90°, 180°, 270°
Issue Method	Batch, On-demand (option), or Auto cut (option)
Weight	17 kg (37.5 lbs.)
Interface	Memory Card Interface ..... 1 slot (for 32 KB or 64 KB SRAM card)
	Serial Interface (RS-232C)
	Centronics Interface
Option	Memory Card: MC32-EX, MC64-EX
	Keyboard: KB-30-EX
	Rewinder: B-1103, B-1103R
	Rewinder unit: B-1103M
	Cutter unit: B-1203M
	Stacker: B-1403

## 2. SUPPLIES

### ● B-30-S1/H1/C1/S2/H2/C2/S3/H3/C3/S5

Item	Supply Type	Label	Tag
Width		30 to 81 mm (1.18 to 3.18 inches)	
Length		15 to 152.4 mm (.59 to 6 inches)	
Thickness		.13 to .17 mm (.005 to .006 inches)	.15 to .26 mm (.006 to .010 inches)
Roll Diameter		230 mm (9 inches) Max.	

### ● B-30-AS2/AS3/AH3/AS5

Item	Supply Type	Label	Tag
Width		30 to 81 mm (1.18 to 3.18 inches)	
Length		15 to 160 mm (.59 to 6.29 inches)	
Thickness		.13 to .17 mm (.005 to .006 inches)	.15 to .26 mm (.006 to .010 inches)
Roll Diameter		230 mm (9 inches) Max.	

## 3. RIBBON

Ribbon Type	One-time carbon: Black
Width	48 mm (1.89 inches), 58 mm (2.28 inches), 83 mm (3.26 inches)
Length	400 m (1312 feet)
Roll Diameter	Max. 71 mm (2.79 inches)

## 4. USING B-1403

Item	Supply Type	Label	Tag
Paper		Paper with a minimum label-to-label gap of 4 mm.	Perforated paper cannot be used.
Width		30 ~ 81 mm (1.18 to 3.19 inches)	30 ~ 81 mm (1.18 to 3.19 inches)
Length		30 ~ 80 mm (1.18 to 3.15 inches)	30 ~ 105 mm (1.18 to 4.1 inches)

4. DIMENSIONS (approximate)

■ Printer

mm (inches)

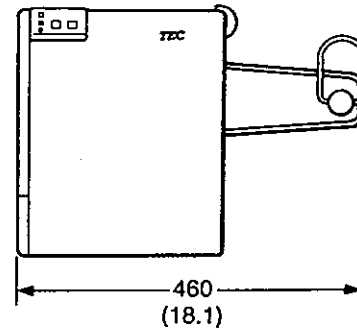
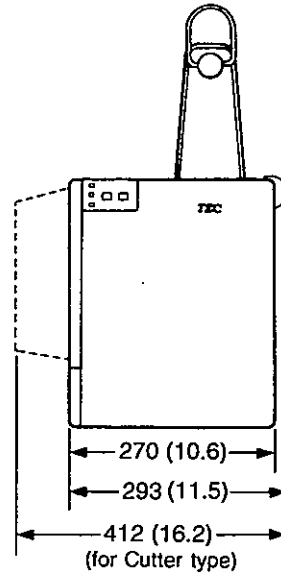
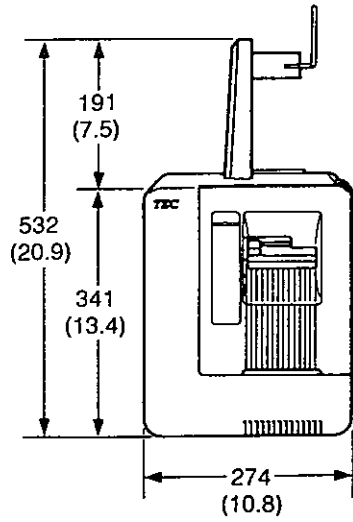

■ Keyboard

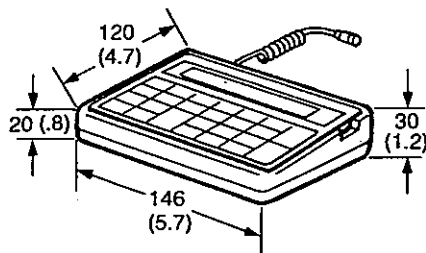

Cable length: 1.5 m (4.92 feet)  
Weight: 430g (.95 lbs.)

5. ACCESSORIES

Make sure you have all the items shown the accessory list on the carton.

NOTE : The specifications are subject to change without notice.

## CHAPTER 2

### BEFORE STARTING UP

1. OVERVIEW .....	2-1
1.1. Front View .....	2-1
1.2. Side View .....	2-5
1.3. Keyboard Unit .....	2-5
2. KEY FUNCTIONS .....	2-6

## 1. OVERVIEW

### 1.1. Front View

#### ● B-30-S1/DS2

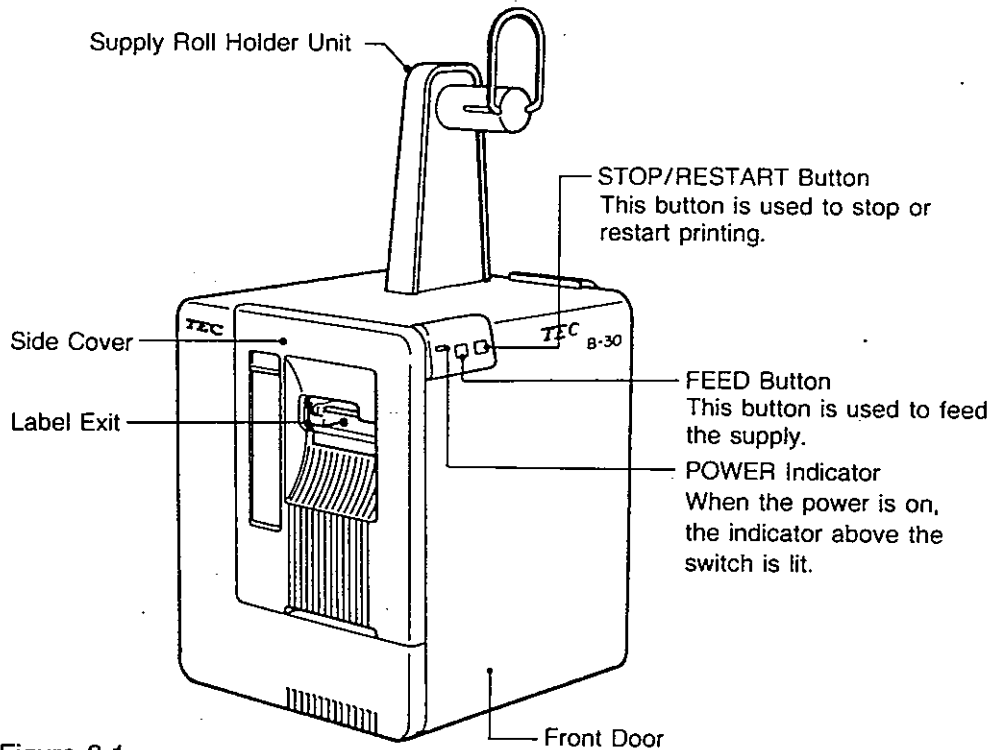

Figure 2-1.

#### ● B-30-S2/S3/AS2/AS3/AS5

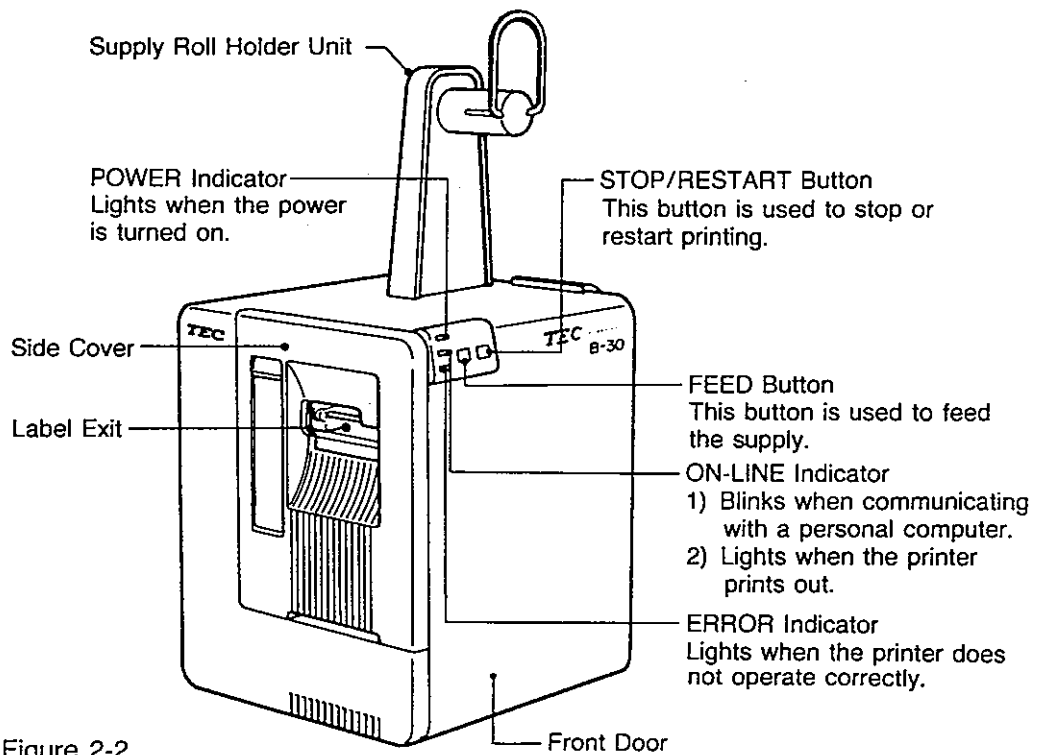

Figure 2-2.



● B-30-H1

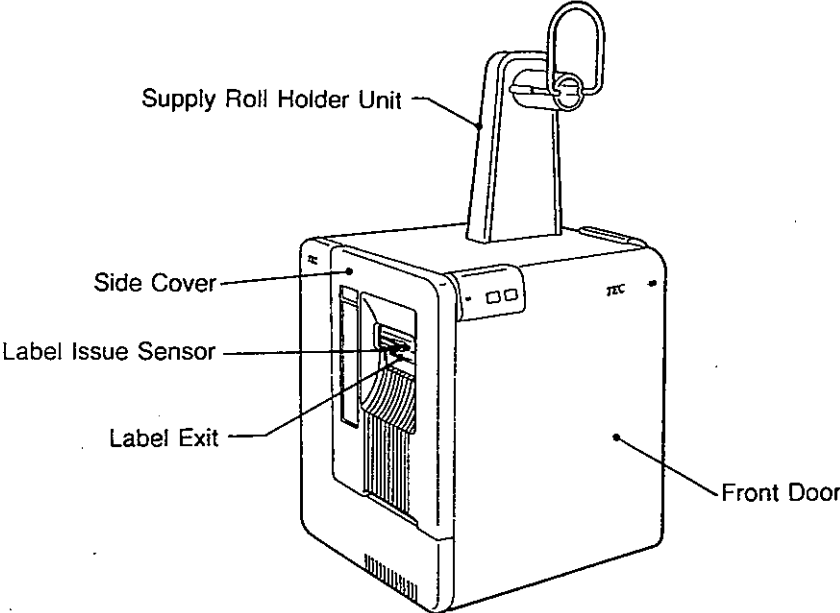

Figure 2-3.

● B-30-H2/H3/AH3

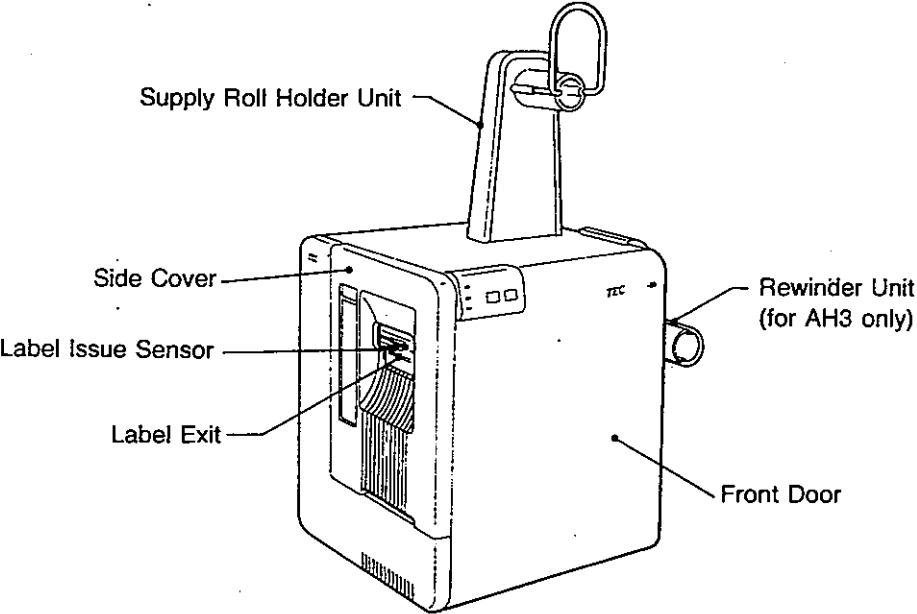

Figure 2-4.

● B-30-S3/AS3/S5/AS5 (with Rewinder unit B-1103M...option)

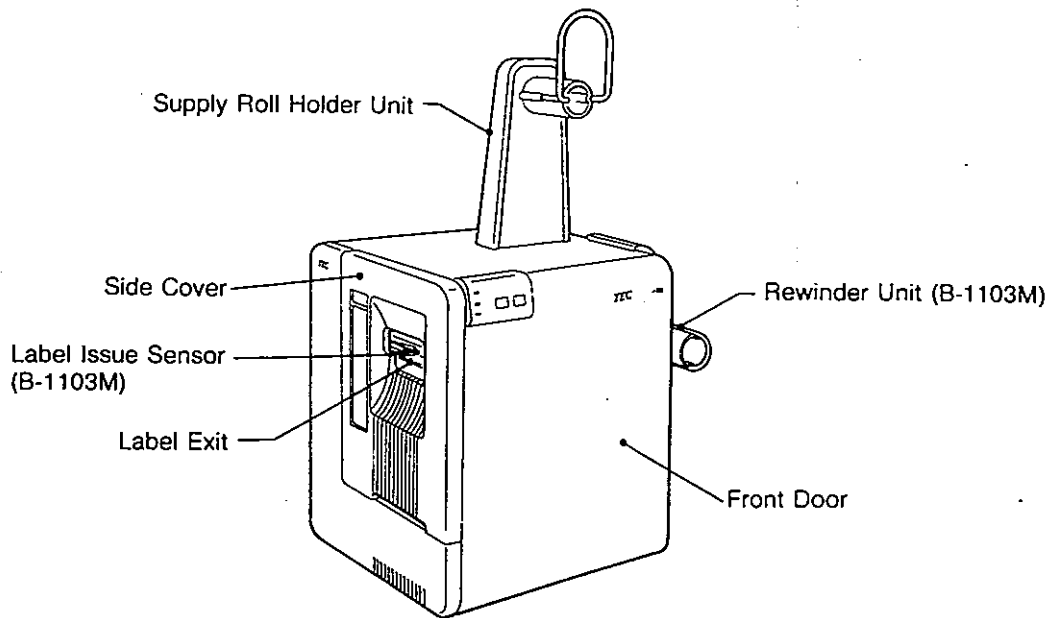

Figure 2-5.

● B-30-C1

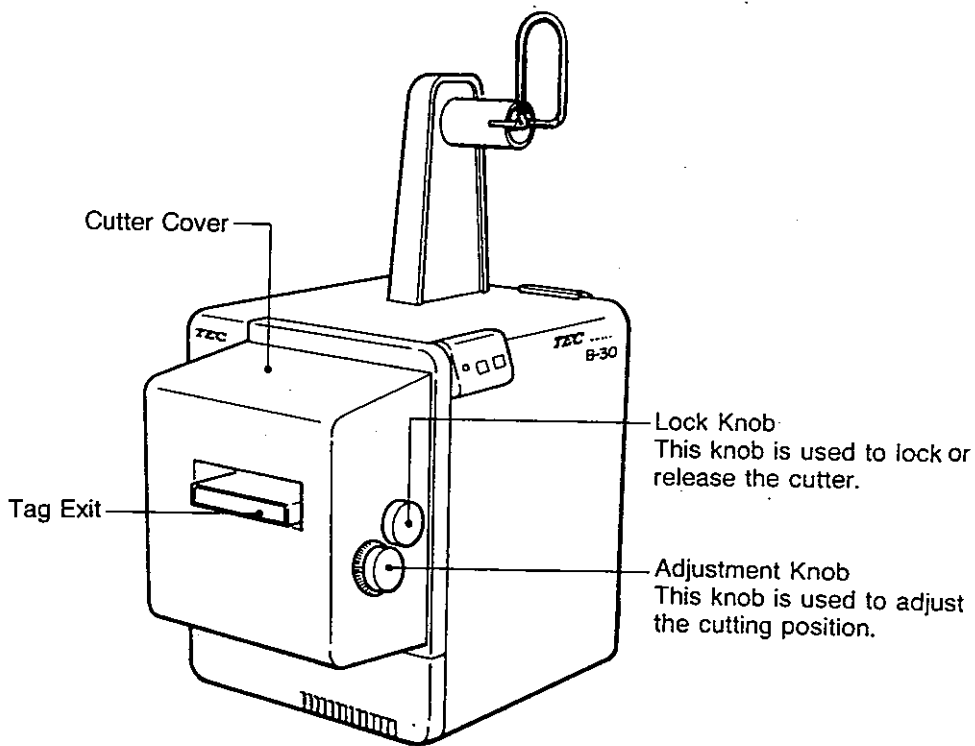

Figure 2-6.

● B-30-C2/C3

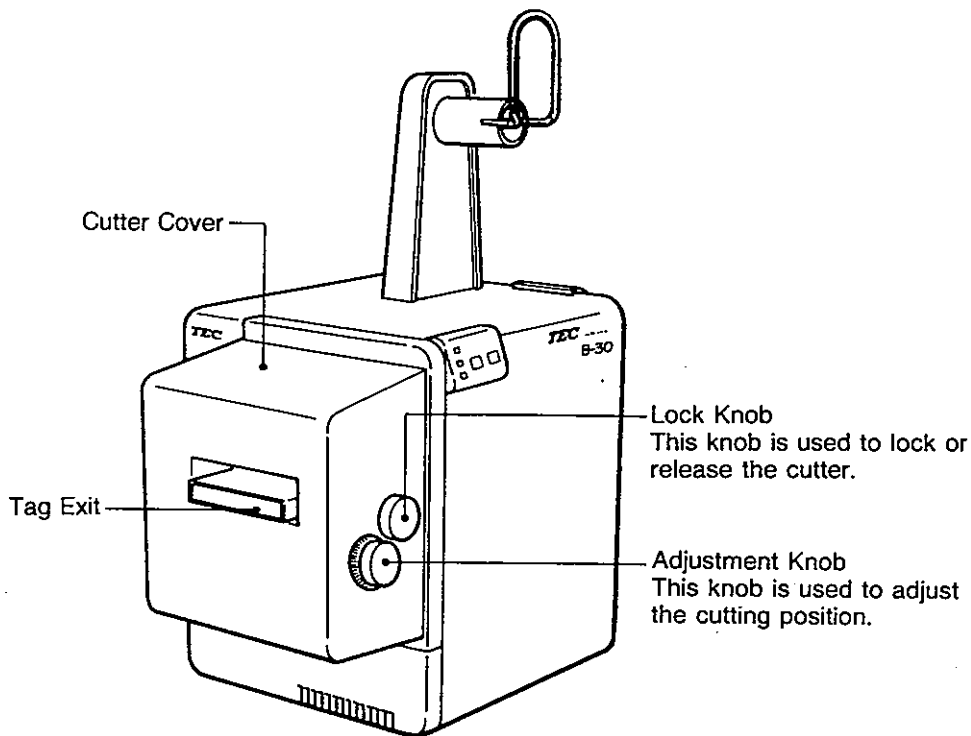

Figure 2-7.

● B-30-S3/AS3/S5/AS5 (with Cutter unit B-1203M....Option)

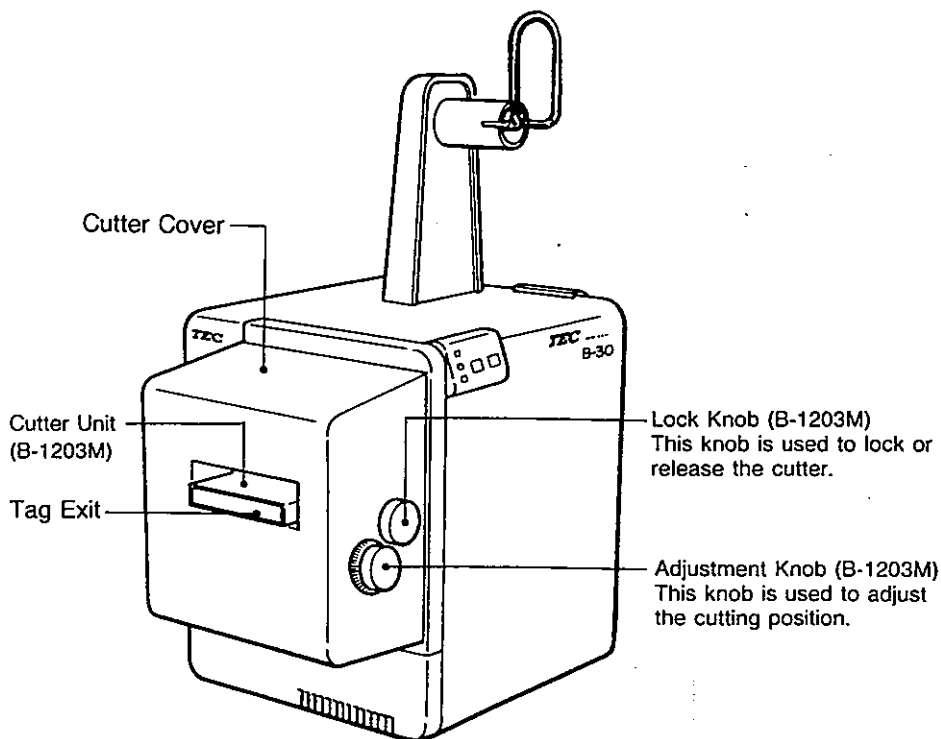

Figure 2-8.

1.2. Side View

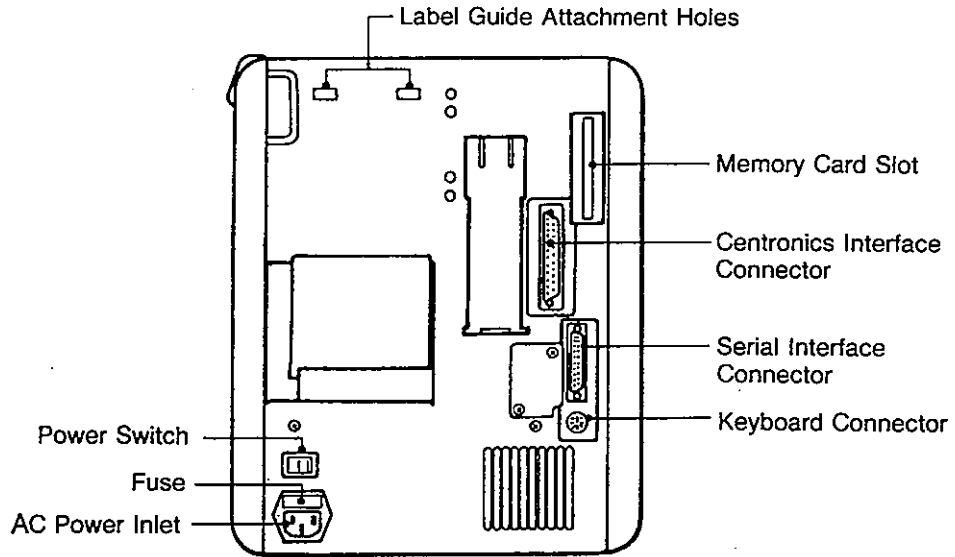

Figure 2-9.

1.3. Keyboard Unit

● KB-30-EX

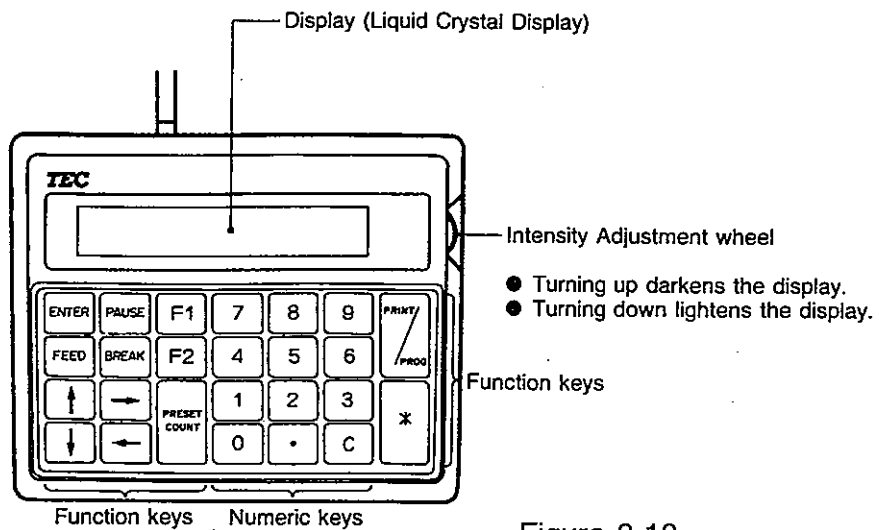

Figure 2-10.

● KB-30-NP

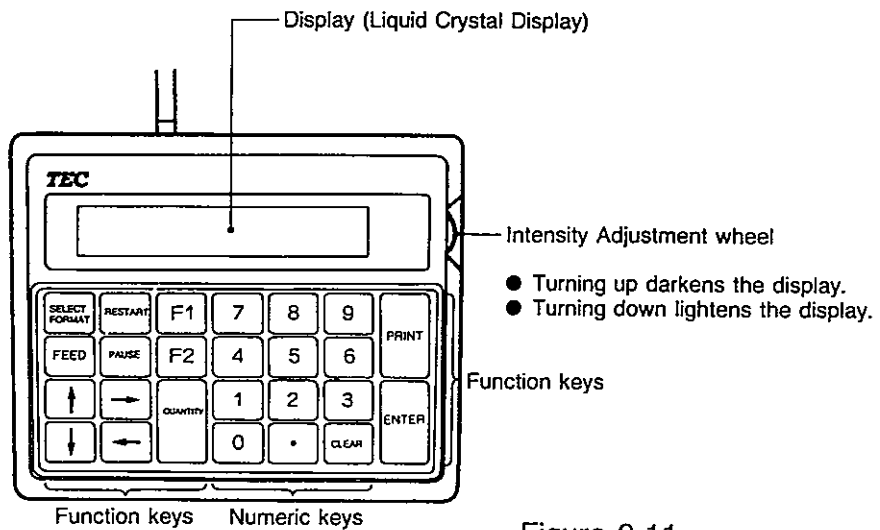

Figure 2-11.

## 2. KEY FUNCTIONS

## ● KB-30-EX

Key	Function
<div style="border: 1px solid black; width: 30px; height: 30px; display: flex; align-items: center; justify-content: center; margin: 0 auto;">C</div>	This key is used for enter-clear of a numeric key. It is also used to release the printer from an error mode.
<div style="border: 1px solid black; width: 30px; height: 30px; display: flex; align-items: center; justify-content: center; margin: 0 auto;">ENTER</div>	This key is used to enter the data recall mode.
<div style="border: 1px solid black; width: 30px; height: 30px; display: flex; align-items: center; justify-content: center; margin: 0 auto;">FEED</div>	This key is used to feed and cut supplies. <b>NOTICE:</b> The available functions are different depending on the program used.
<div style="display: flex; justify-content: space-around; align-items: center; margin: 0 auto;"> <div style="border: 1px solid black; width: 30px; height: 30px; display: flex; align-items: center; justify-content: center;">F1</div> <div style="border: 1px solid black; width: 30px; height: 30px; display: flex; align-items: center; justify-content: center;">F2</div> </div>	Special assigned function. (These keys are used by service personnel.)
<div style="border: 1px solid black; width: 30px; height: 30px; display: flex; align-items: center; justify-content: center; margin: 0 auto;">PAUSE</div>	This key is used to temporarily stop printing. It is also used to restart printing supplies after pausing.
<div style="border: 1px solid black; width: 30px; height: 30px; display: flex; align-items: center; justify-content: center; margin: 0 auto;">PRESET COUNT</div>	This key is used to preset the number of tags/labels you want to print.
<div style="border: 1px solid black; width: 30px; height: 30px; display: flex; align-items: center; justify-content: center; margin: 0 auto;">PRINT/ PROG.</div>	This key is used to start printing. It is also used to register the next data while the supplies are being printed.
<div style="border: 1px solid black; width: 30px; height: 30px; display: flex; align-items: center; justify-content: center; margin: 0 auto;">*</div>	This key is used to input the data to the printer.
<div style="border: 1px solid black; width: 30px; height: 30px; display: flex; align-items: center; justify-content: center; margin: 0 auto;">.</div>	This key is used to separate plural input data.
<div style="display: flex; align-items: center; justify-content: center; margin: 0 auto;"> <div style="border: 1px solid black; width: 30px; height: 30px; display: flex; align-items: center; justify-content: center;">0</div> <span style="margin: 0 5px;">~</span> <div style="border: 1px solid black; width: 30px; height: 30px; display: flex; align-items: center; justify-content: center;">9</div> </div>	These keys are used to enter numeric data.
Other keys	These keys are not used during normal operations. (These keys are also used by service personnel.)

## ● KB-30-NP

Key	Function
<div style="border: 1px solid black; padding: 2px; display: inline-block;">CLEAR</div>	This key is used for enter-clear of a numeric key. It is also used to release the printer from an error mode.
<div style="border: 1px solid black; padding: 2px; display: inline-block;">ENTER</div>	This key is used to enter the data to the printer.
<div style="border: 1px solid black; padding: 2px; display: inline-block;">FEED</div>	This key is used to feed and cut supplies. <b>NOTICE:</b> The available functions are different depending on the program used.
<div style="border: 1px solid black; padding: 2px; display: inline-block;">PAUSE</div>	This key is used to temporarily stop printing.
<div style="border: 1px solid black; padding: 2px; display: inline-block;">PRINT</div>	This key is used to start printing.
<div style="border: 1px solid black; padding: 2px; display: inline-block;">QUANTITY</div>	This key is used to preset the number of tags/labels you want to print.
<div style="border: 1px solid black; padding: 2px; display: inline-block;">RESTART</div>	This key is used to select a print format.
<div style="border: 1px solid black; padding: 2px; display: inline-block;">SELECT FORMAT</div>	This key is used to select a print format.
<div style="border: 1px solid black; padding: 2px; display: inline-block;">.</div>	This key is used to separate plural input data.
<div style="display: inline-block; margin-right: 10px;"> <div style="border: 1px solid black; padding: 2px;">F1</div> </div> <div style="border: 1px solid black; padding: 2px;">F2</div>	F2 is a purchase order separator. (These keys are also used by service personnel.)
<div style="display: inline-block; margin-right: 10px;"> <div style="border: 1px solid black; padding: 2px;">0</div> </div> <div style="margin-right: 10px;">~</div> <div style="border: 1px solid black; padding: 2px;">9</div>	These keys are used to enter numeric data.
<div style="display: inline-block; margin-right: 10px;"> <div style="border: 1px solid black; padding: 2px;">↑</div> </div> <div style="border: 1px solid black; padding: 2px;">←</div> <div style="display: inline-block; margin-right: 10px;"> <div style="border: 1px solid black; padding: 2px;">↓</div> </div> <div style="border: 1px solid black; padding: 2px;">←</div>	These keys are used to during normal operations to move the cursor within a data field and to display formats.

## CHAPTER 3

### INSTALLING THE PRINTER

1. CONNECTING THE POWER CORD AND CABLES.....	3-1
2. INSTALLING THE SUPPLY ROLL HOLDER.....	3-1
3. INSTALLING THE SUPPLY STOPPER B .....	3-2
4. INSTALLING THE PAPER GUIDE .....	3-3
5. INSTALLING THE BACKING PAPER GUIDE.....	3-3
6. MOUNTING THE LOCK AND ADJUSTMENT KNOBS .....	3-4
■ Adjusting the cutting position .....	3-4
7. INSTALLING THE STACKER.....	3-4
8. INSTALLING THE REWINDER B-1103.....	3-5

## 1. CONNECTING THE POWER CORD AND CABLES

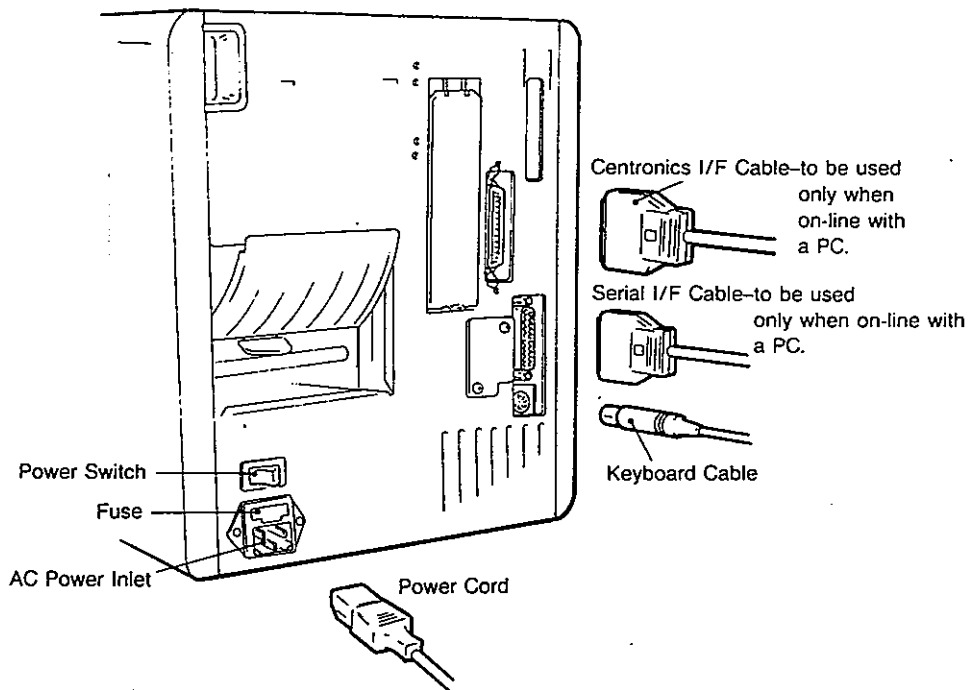

Figure 3-1.

**WARNING:** The power switch must be off before connecting the power cord.

## 2. INSTALLING THE SUPPLY ROLL HOLDER

- Installing the supply roll holder on the top of the printer.
  - a. Remove the cover of the supply roll holder unit, and attach the supply stand to the top of the printer using the two wing screws.
  - b. Insert the cover over the top of the supply stand.

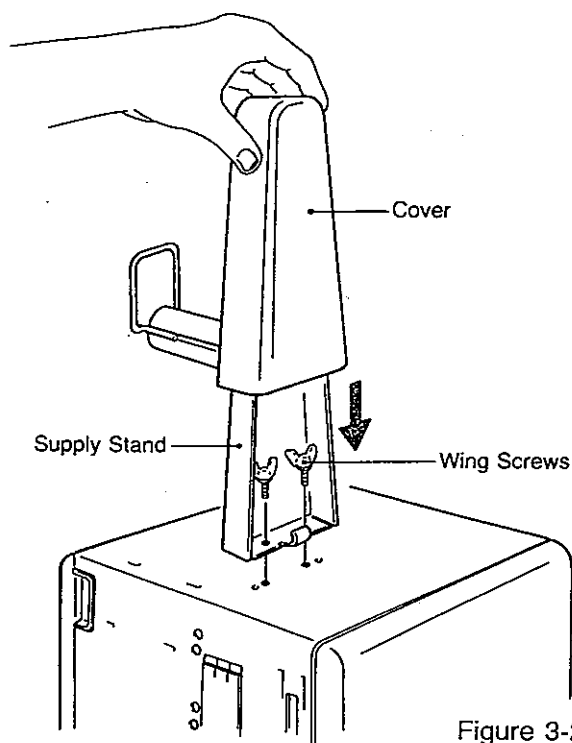

Figure 3-2.



- Installing the supply roll holder on the right side of the printer (except for B-30-S3/AS3 with Rewinder unit).
  - a. Remove the cover of the supply roll holder unit, then remove the supply spool from the supply stand.
  - b. Attach the supply stand to the right side of the printer using the two wing screws.
  - c. Mount the supply spool by inserting it into the horizontal mounting holes of the supply stand.
  - d. Attach the cover by inserting it horizontally from the side of the supply stand.

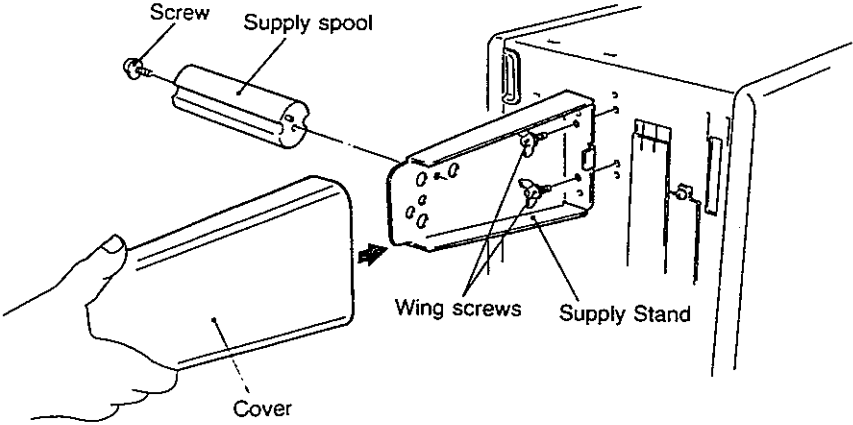

Figure 3-3.

**3. INSTALLING THE SUPPLY STOPPER B**

Install supply stopper B on the supply roll holder unit when using the narrow supply.

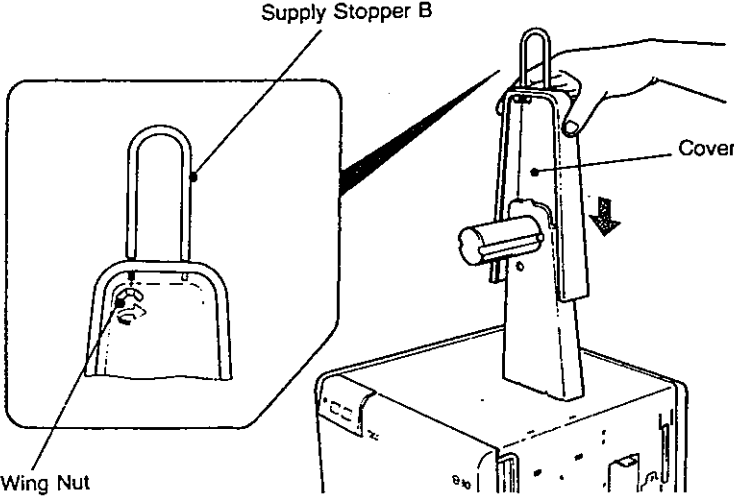

Figure 3-4.

#### 4. INSTALLING THE PAPER GUIDE

Place the paper guide in the position shown below.

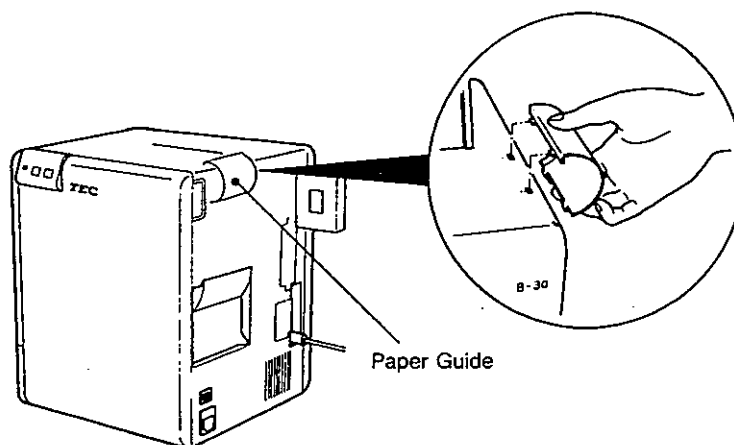

Figure 3-5.

#### 5. INSTALLING THE BACKING PAPER GUIDE (for B-30-H1/H2/H3)

When issuing a label in the "On-demand" mode, mount the backing paper guide in the position shown below and eject the backing paper from the lower exit on the left side of the printer.

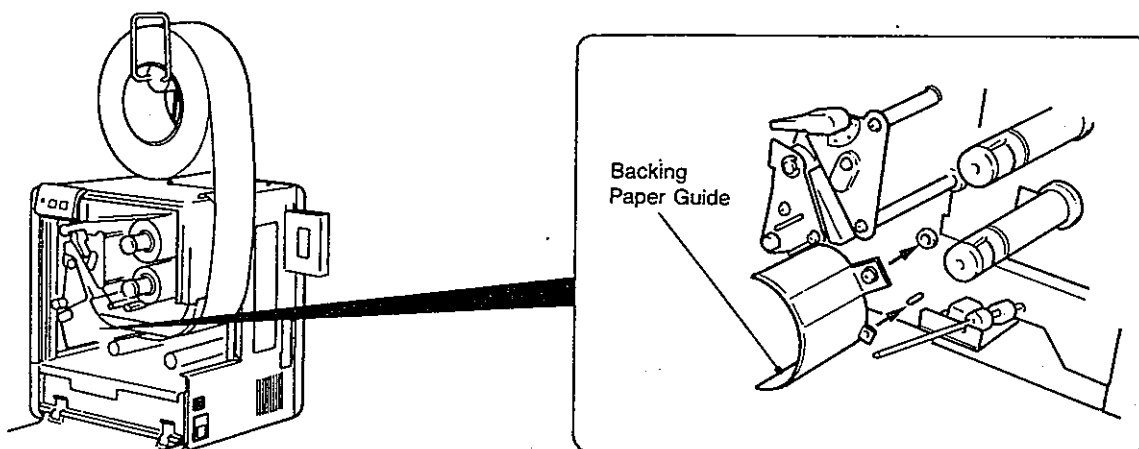

Figure 3-6.

6. MOUNTING THE LOCK AND ADJUSTMENT KNOBS (for Cutter type only)

Insert each knob. (Align the groove of the knob with the pin on the shaft.)

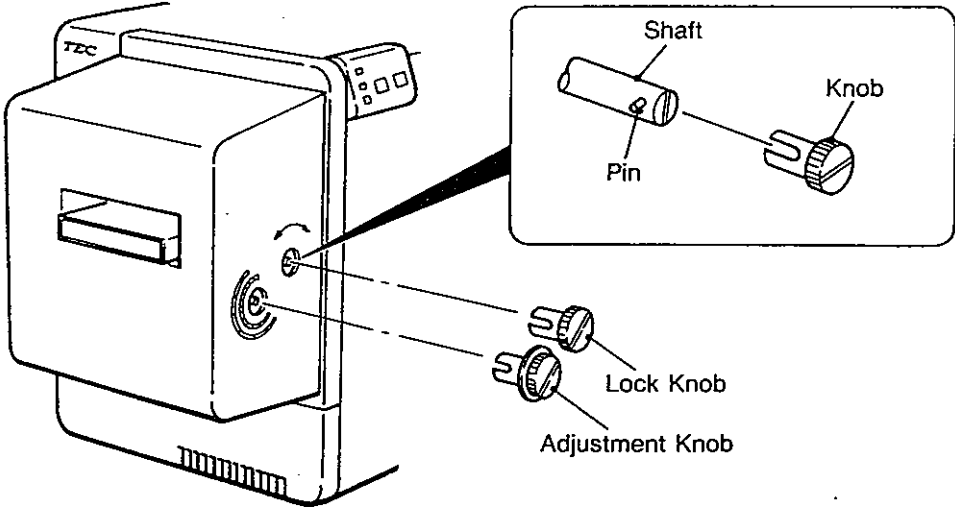

Figure 3-7.

NOTICE: When inserting the adjustment knob, make sure that the triangular indicator (▲) points to "55" on the scale.

■ Adjusting the cutting position

1. Turn the lock knob to the unlock position.
2. Set the adjustment knob to the designated position.
3. Turn the lock knob to the lock position.

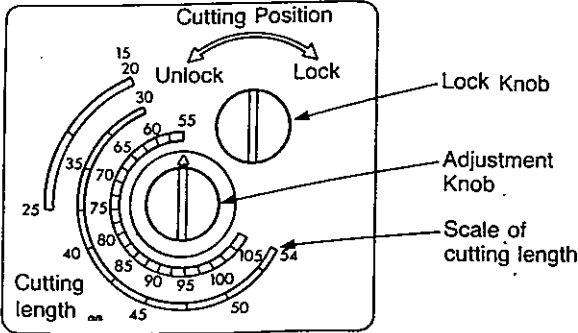

Figure 3-8.

- 1st scale: 55 mm ~ 108 mm Max.
- 2nd scale: 30 mm ~ 54
- 3rd scale: 15 mm, 20 mm ~ 25 mm

7. INSTALLING THE STACKER (for Cutter type only)

Assemble the stacker and hang the tabs of the stacker on the tag exit.

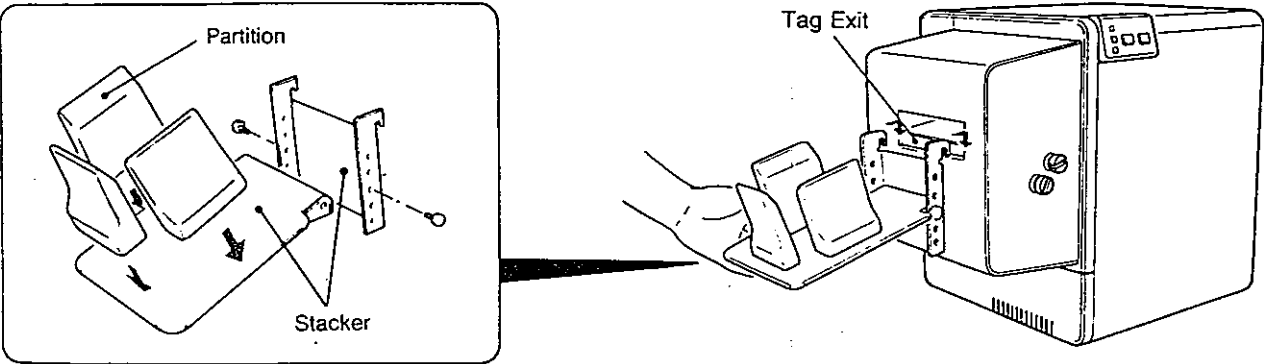

Figure 3-9.

## 8. INSTALLING THE REWINDER B-1103 (Option)

To rewind labels issued in batch printing mode, or backing paper in the on-demand printing mode, attach the Rewinder B-1103 (option) at the position shown below.

- Label (except for Cutter type)

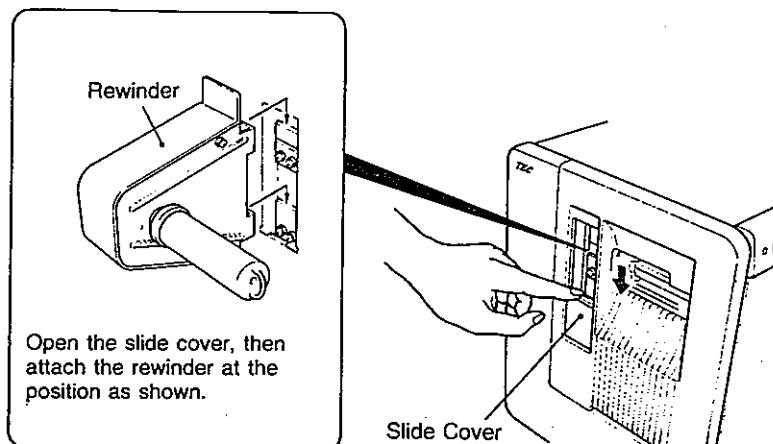

Figure 3-10.

- Backing Paper (for B-30-H1/H2/H3 only)

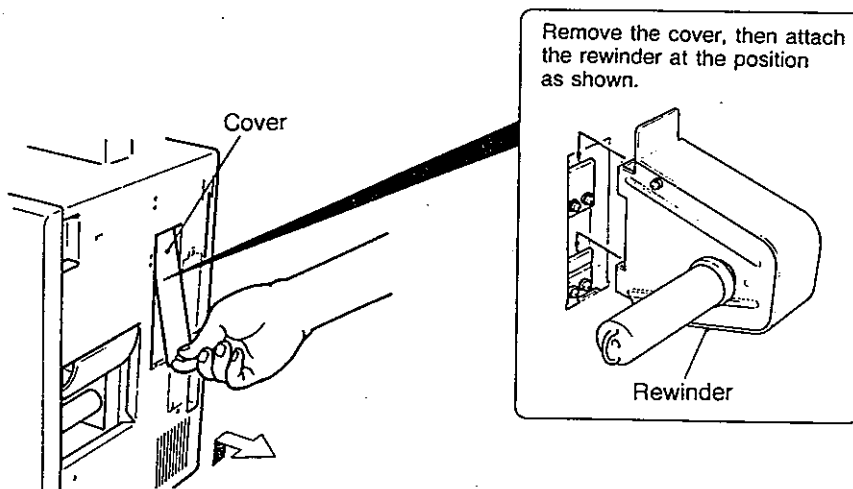

Figure 3-11.

- Backing Paper Threading

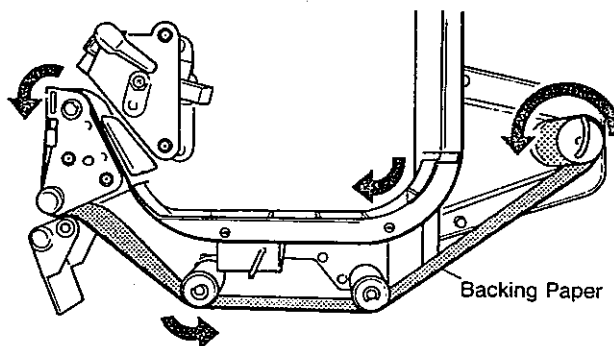

Figure 3-12.

**NOTICE:** When installing other optional equipments, refer to the owner's manual provided with those equipment.

## CHAPTER 4

### OPERATION

1. LOADING THE RIBBON.....	4- 1
2. LOADING SUPPLIES .....	4- 4
2.1. For B-30-S1/H1/C1/DS2.....	4- 4
2.2. For B-30-S2/H2/C2/S3/H3/C3/AS2/AS3/AH3 .....	4- 6
2.3. For B-30-S5/AS5.....	4- 8
■ Threading the backing paper.....	4-10
3. INSERTING THE MEMORY CARD.....	4-11
4. ADJUSTING THE SENSORS.....	4-12
4.1. Black Mark or Feed Gap Sensor .....	4-12
4.2. Label Issue Sensor.....	4-12

## 1. LOADING THE RIBBON

There are two types of supplies, standard paper and thermal paper.  
**DO NOT LOAD** a ribbon when using thermal paper.

1. Turn the power off.
2. Open the front door.

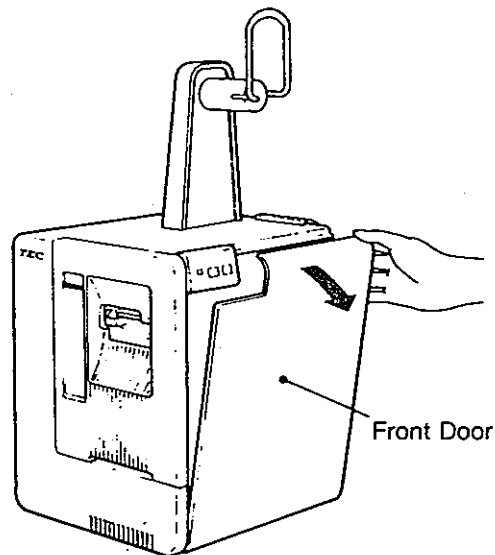

Figure 4-1.

3. Move the head lock lever to the right to release the print head.
4. Remove the supply if it has been loaded.

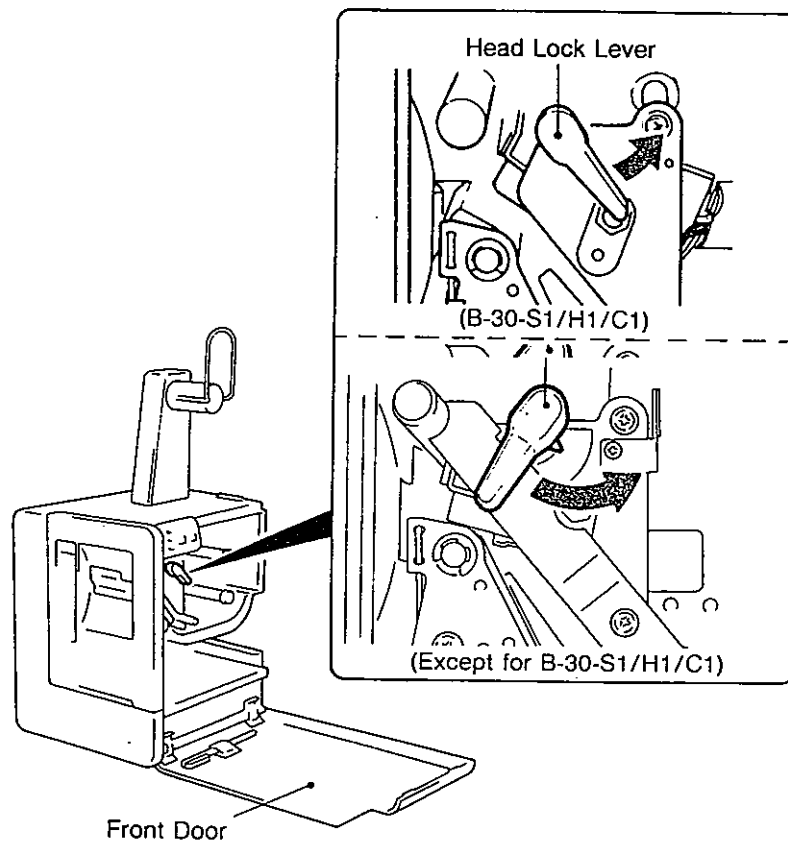

Figure 4-2.

5. Load the ribbon.
  - a. Guide the edge of the ribbon around the ribbon shaft.
  - b. Place the ribbon rolls onto the two shafts.
  - c. Insert the ribbon between the ribbon end sensor.

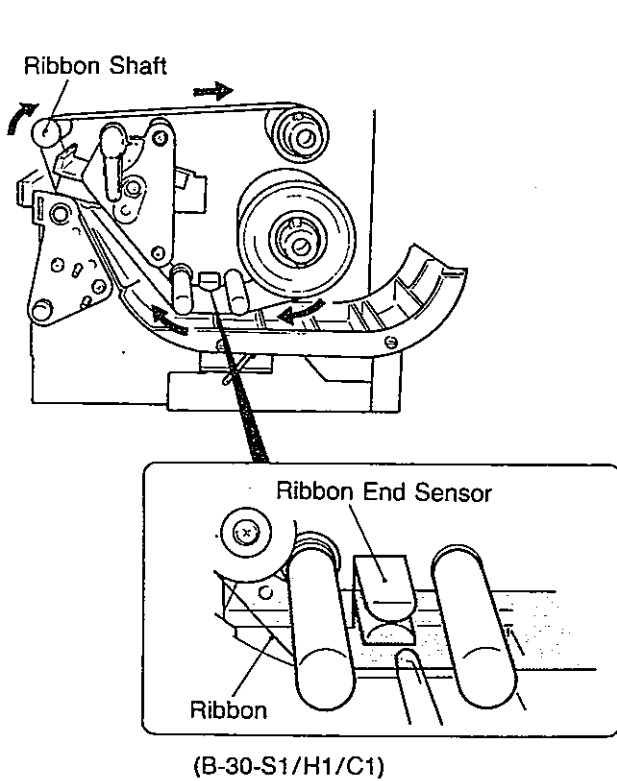

Figure 4-3.

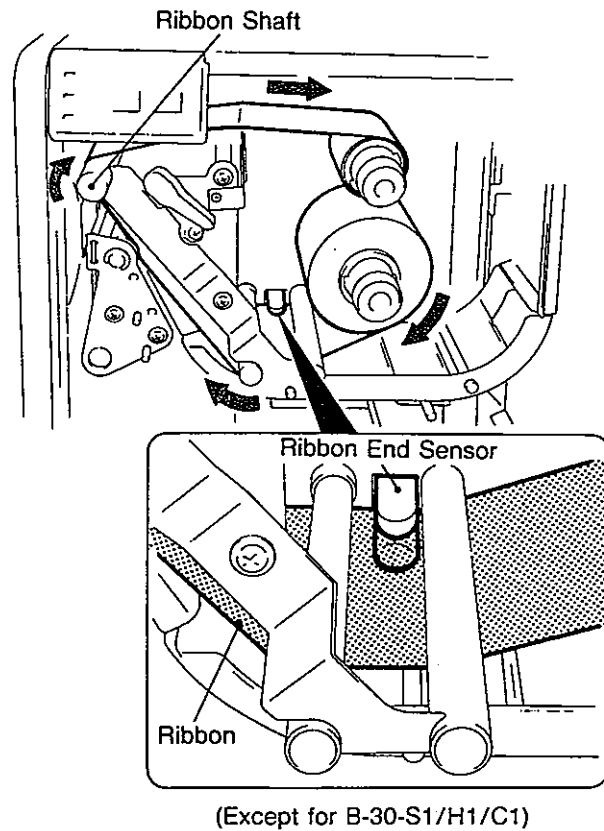

Figure 4-4.

6. Lock the ribbon rolls.
  - a. Match the notch on the supply and rewind reels with the protrusion on the shafts as shown.

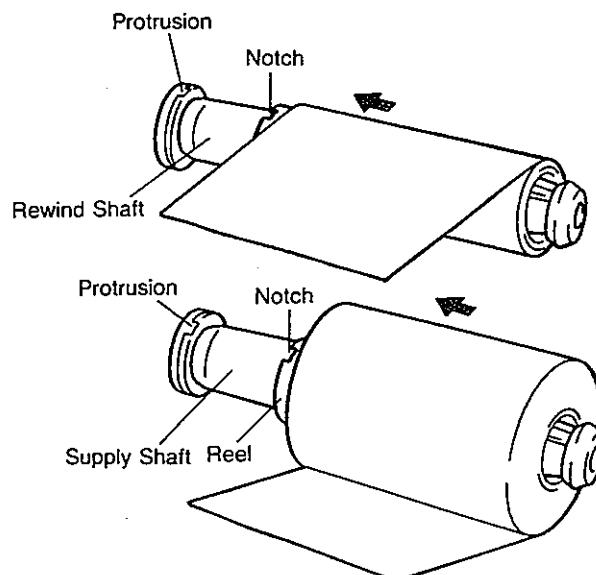

Figure 4-5.

- b. Pull the head of the shaft while holding the ribbon roll.

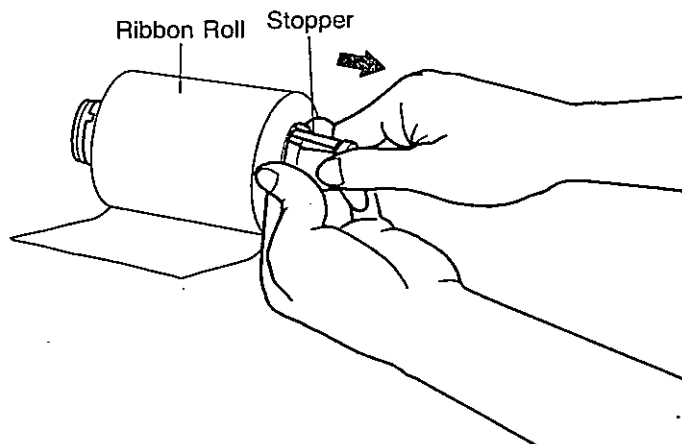

Figure 4-6.

**NOTICE:** Depress the stoppers when removing the ribbon roll.

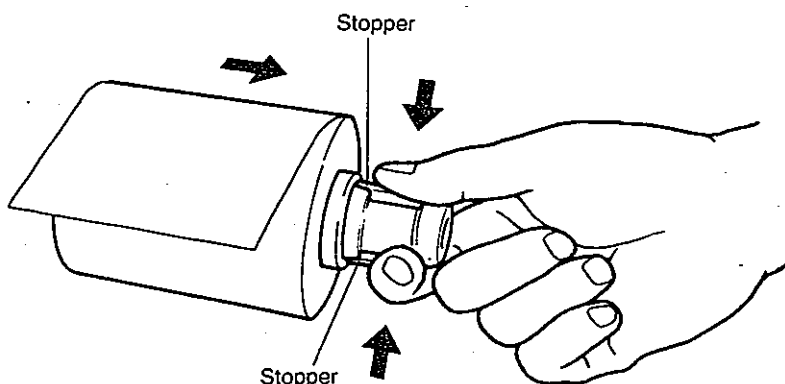

Figure 4-7.

7. Turn the rewind shaft as shown, to pull the ribbon tight.
8. Reload the supply (standard paper).
9. Move the head lock lever to the left to move the print head against the ribbon and platen.
10. Close the front door.

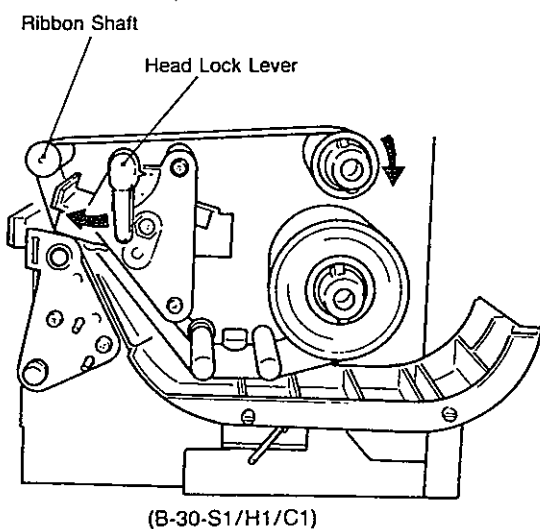

Figure 4-8.

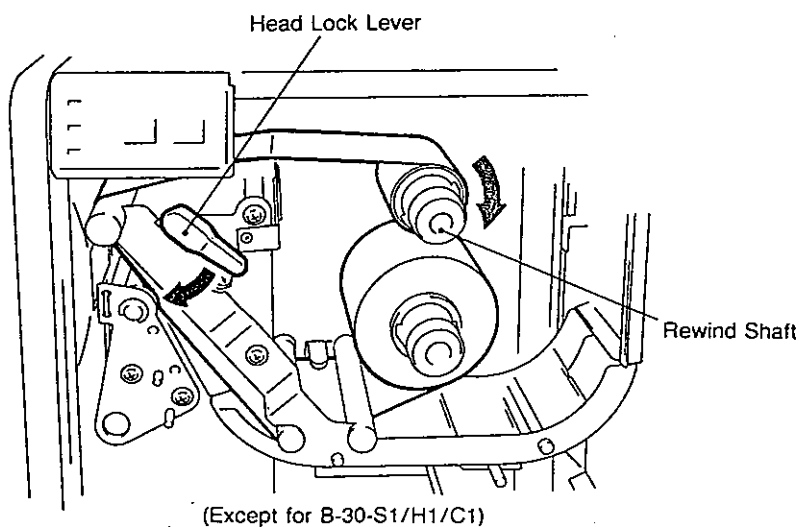

Figure 4-9.



## 2. LOADING SUPPLIES

### 2.1. For B-30-S1/H1/C1/DS2

The printer prints both tags and labels.

1. Turn the power off.
2. Place the supply roll onto the supply roll holder.
3. Open the front door.
4. Move the head lock lever to the right to release the print head.

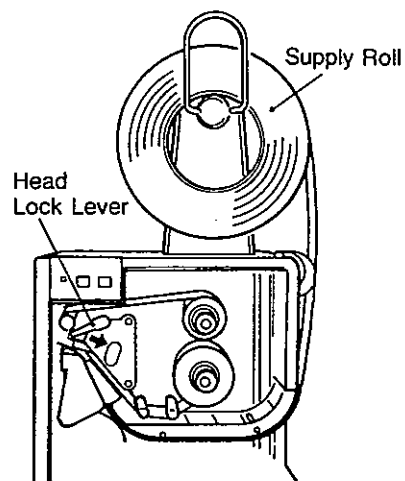

Figure 4-10.

5. Thread the supply as shown.
  - a. Pull enough supply out from the roll to reach the label exit (for H1 and S1 types) or platen (for C1 type).
  - b. Pull down and hold the guide roller lever, and slide the supply under the paper guide. Then release the lever.
  - c. Insert the supply between the label sensors.
  - d. Feed the supply to the label exit or platen as shown below, and push the inside edge of the supply against the back wall.

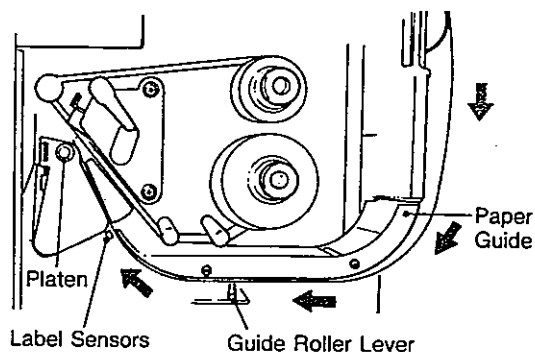

Figure 4-11.

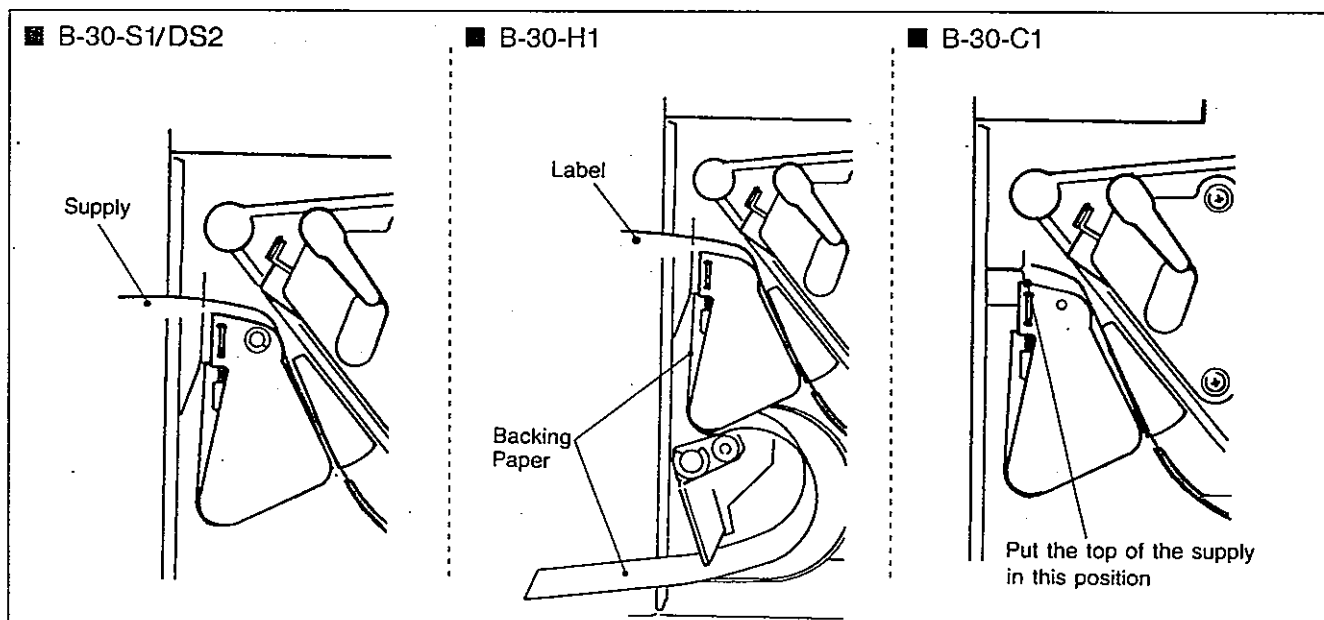

Figure 4-12.

6. Move the head lock lever to position 1 or 2 according to the thickness of the supply.

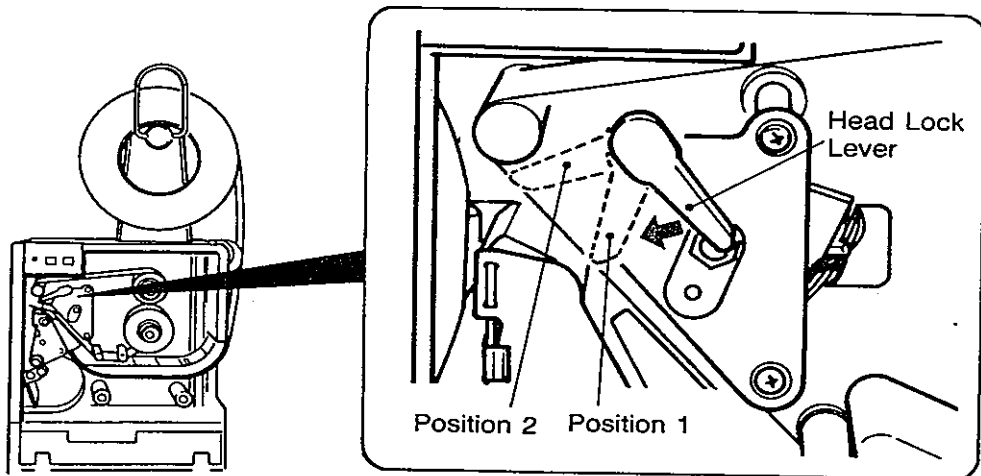

Figure 4-13. Position 1: Thin paper  
Position 2: Thick paper

7. Close the front door.

## 2.2. For B-30-S2/H2/C2/S3/H3/C3/AS2/AS3/AH3

The printer prints both tags and labels.

1. Turn the power off.
2. Place the supply roll onto the supply roll holder.
3. Open the front door.
4. Move the head lock lever to the right to release the print head.

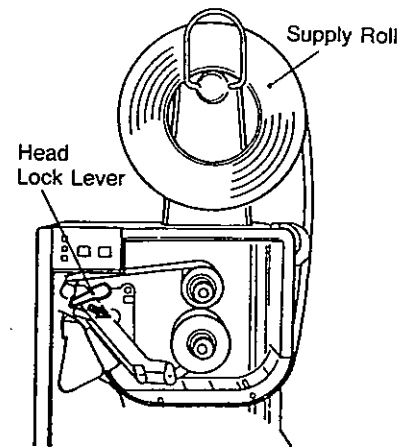

Figure 4-14.

5. Press down the roller open lever to release the skew roller.

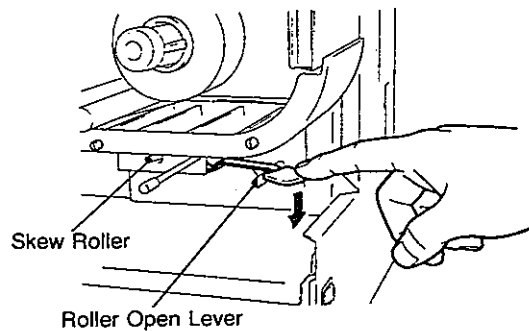

Figure 4-15.

6. Thread the supply as shown.
  - a. Pull enough supply out from the roll to reach the paper setting zone.
  - b. Slide the supply under the paper guide, and push the inside edge of the supply against the back wall.

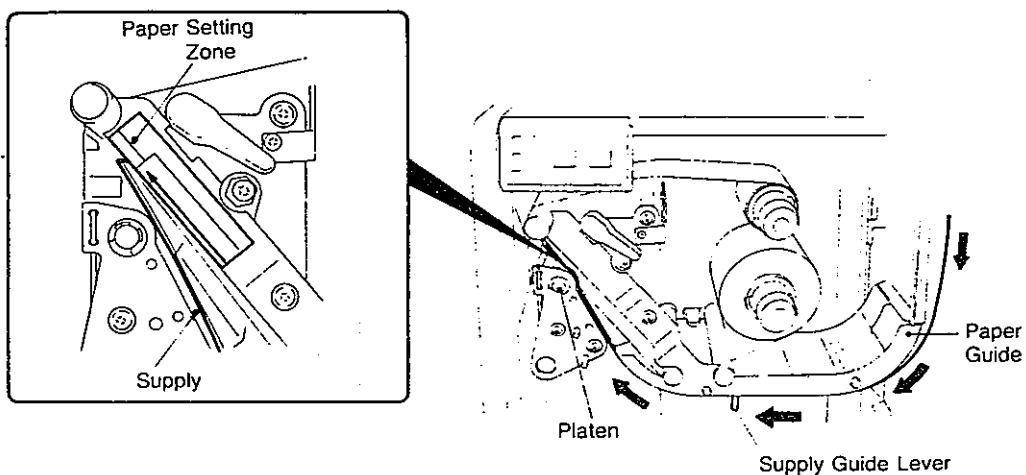

Figure 4-16.

7. Push the roller close lever.

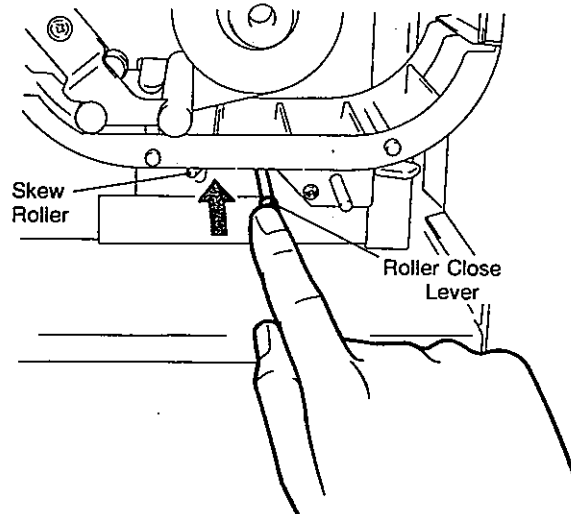

Figure 4-17.

8. Move the head lock lever to position 1 or 2 according to the thickness of the supply.

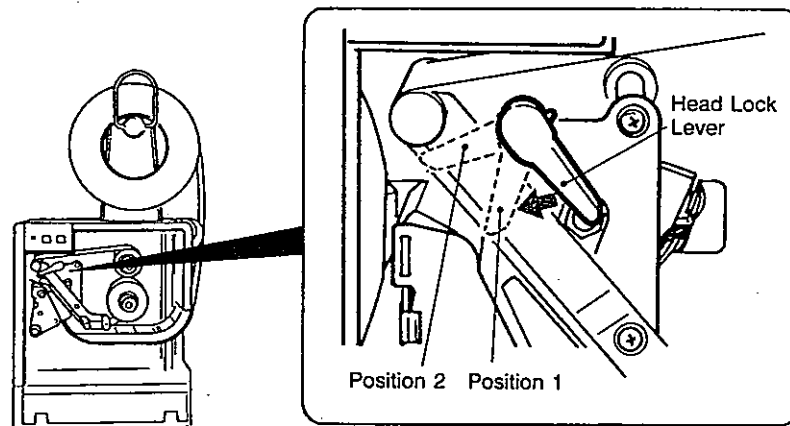

Figure 4-18. Position 1: Thin paper  
Position 2: Thick paper

9. Close the front door.

### 2.3. For B-30-S5/AS5

The printer prints both tags and labels.

1. Turn the power off.
2. Place the supply roll onto the supply roll holder.
3. Open the front door.
4. Move the head lock lever to the right to release the print head.

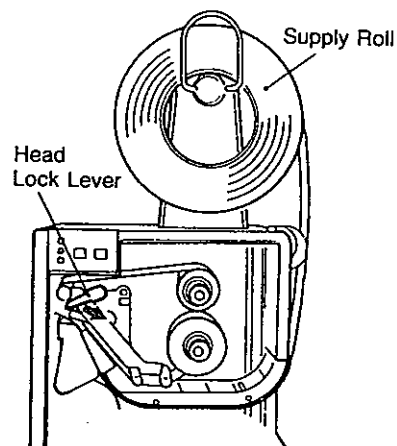

Figure 4-26.

5. Thread the supply as shown.
  - a. Pull enough supply out from the roll to reach the paper setting zone.
  - b. Slide the supply under the paper guide, and push the inside edge of the supply against the back wall.

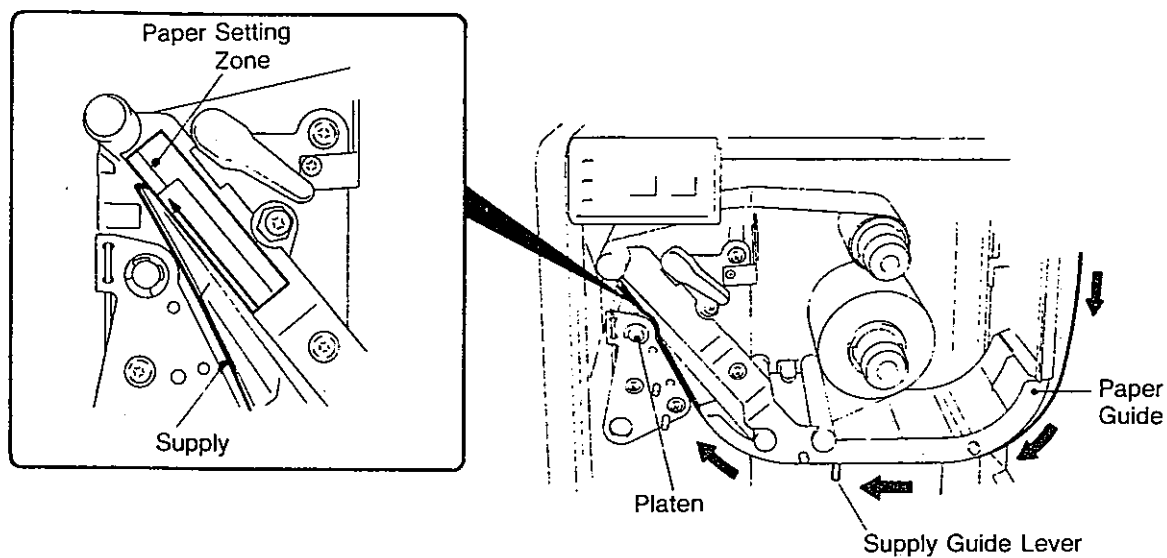

Figure 4-27.

6. Move the head lock lever to position 1 or 2 according to the thickness of the supply.

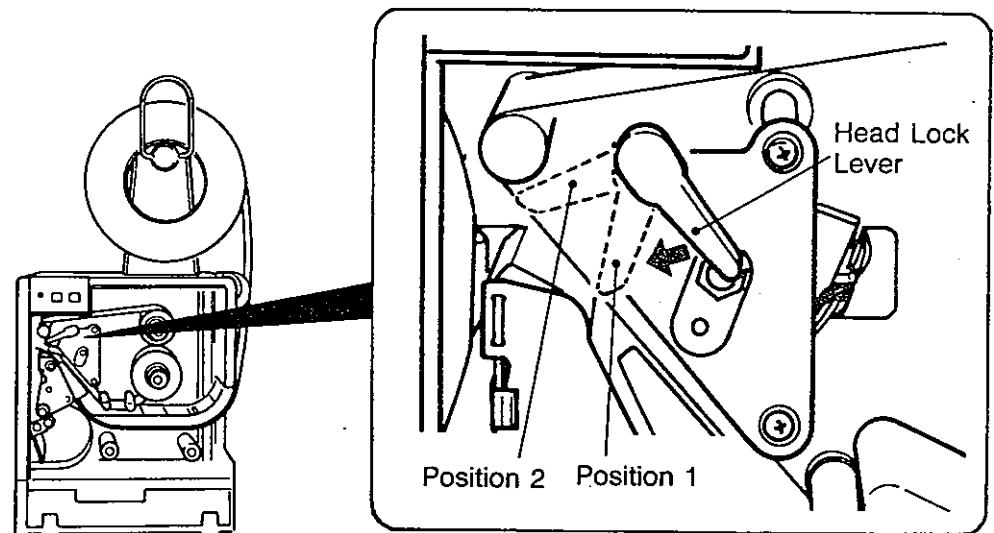

Figure 4-28. Position 1: Thin paper  
Position 2: Thick paper

7. Use the supply guide lever to fit the supply guide to the supply.

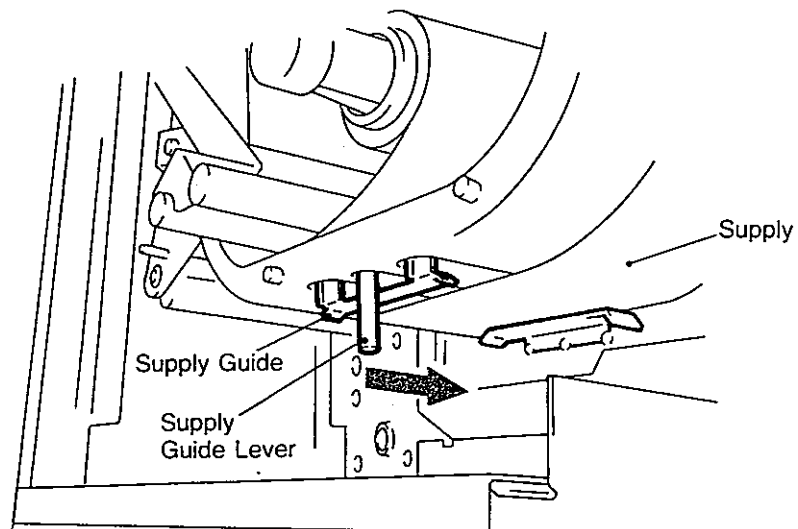

Figure 4-29.

8. Close the front door.

**■ Threading the backing paper (B-30-AH3 and B-30-H3/S3/AS3/S5/AS5 with Rewinder unit)**

To rewind backing paper in the on-demand printing mode, thread the backing paper shown below.

1. Pass the backing paper under the guide rollers.
2. Secure the backing paper to the rewind shaft with clamp.

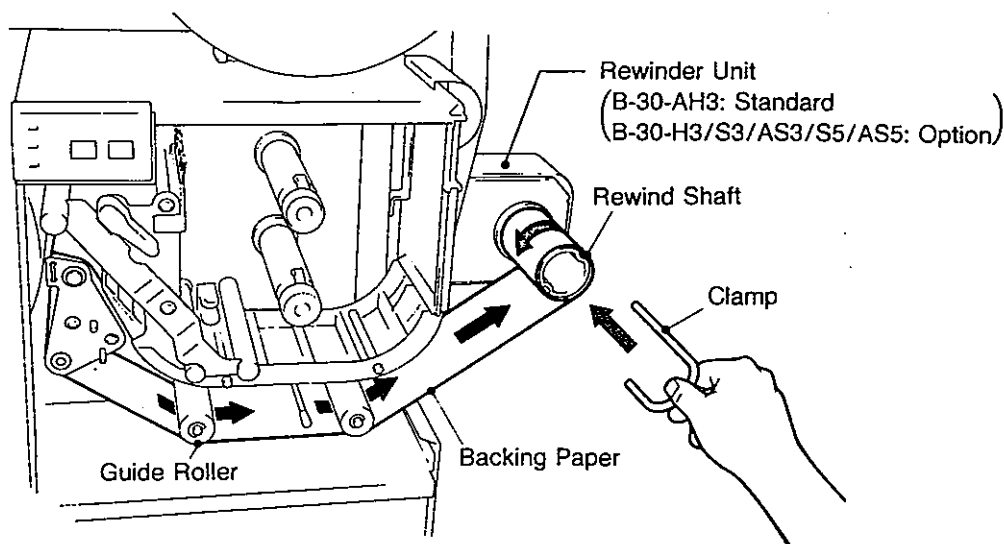

Figure 4-19.

### 3. INSERTING THE MEMORY CARD

1. Turn the power off.
2. Insert the memory card with preregistered print data into the memory card slot.
3. To prevent the memory card from being removed accidentally, be sure to attach the memory card cover.

**WARNING:** Replace battery with Hitachi Maxell Ltd., type CR2016 only. Use of another battery may present a risk of fire or explosion.

**WARNING:** A battery may explode if handled improperly. **DO NOT** recharge, disassemble or dispose of in fire.

**NOTICE:** The data is protected by a backup battery which is installed inside the memory card. The service life of the battery is eighteen (18) months. To replace the battery, consult your TEC dealer or service representative. If the memory card is used with an expired battery, correct operations are not guaranteed by TEC.

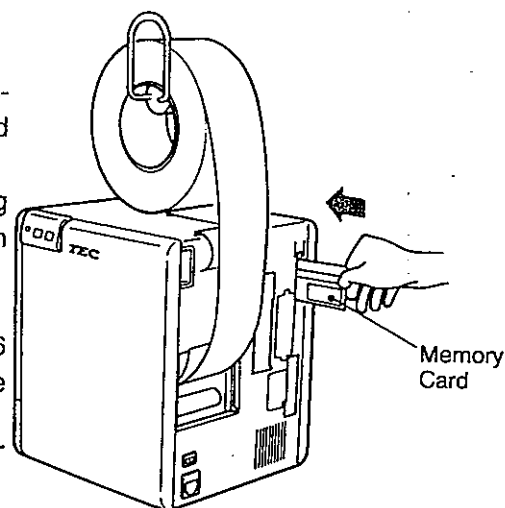

Figure 4-20.

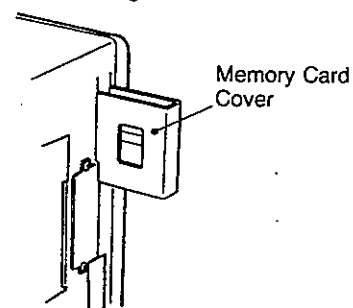
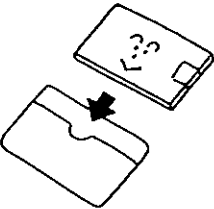
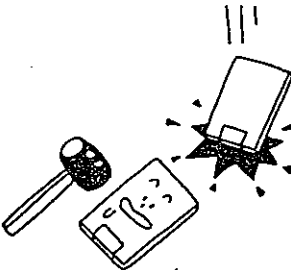
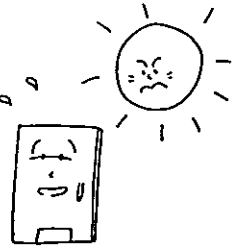
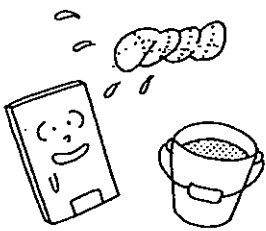
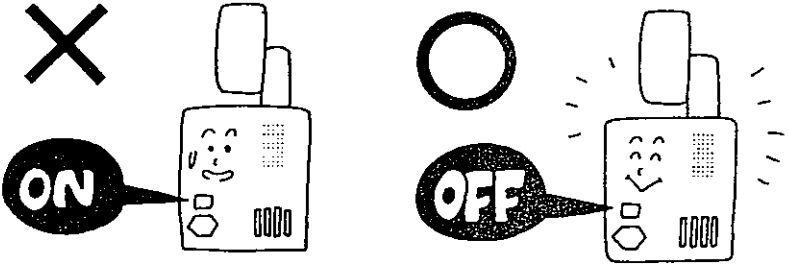

Figure 4-21.

#### ■ PRECAUTIONS

<p>Be sure to protect a memory card by inserting it into its protective cover.</p> 	<p>Do not apply a shock or excessive force to the memory card.</p> 
<p>Do not allow any memory card to be exposed to excessive heat by leaving it in sunlight or bringing it close to a heater.</p> 	<p>Do not expose any memory card to excessive humidity by wiping it with a wet cloth or leaving it in a damp place.</p> 
<p>Before inserting or removing the memory card, be sure to check that the POWER switch is turned OFF.</p> 	



## 4. ADJUSTING THE SENSORS

The sensors detect black marks or feed gaps. The adjustment shafts move the sensors in and out.

### 4.1. Black Mark or Feed Gap Sensor

Adjust the position of the sensor according to the length, from the left end of the supply to the black mark or from the center of the feed gap.

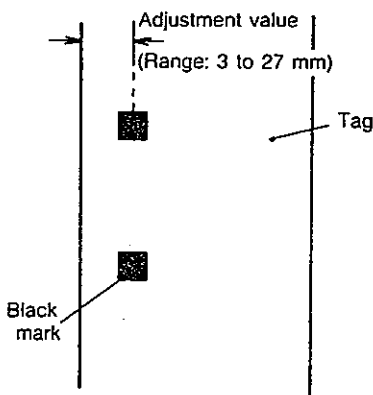
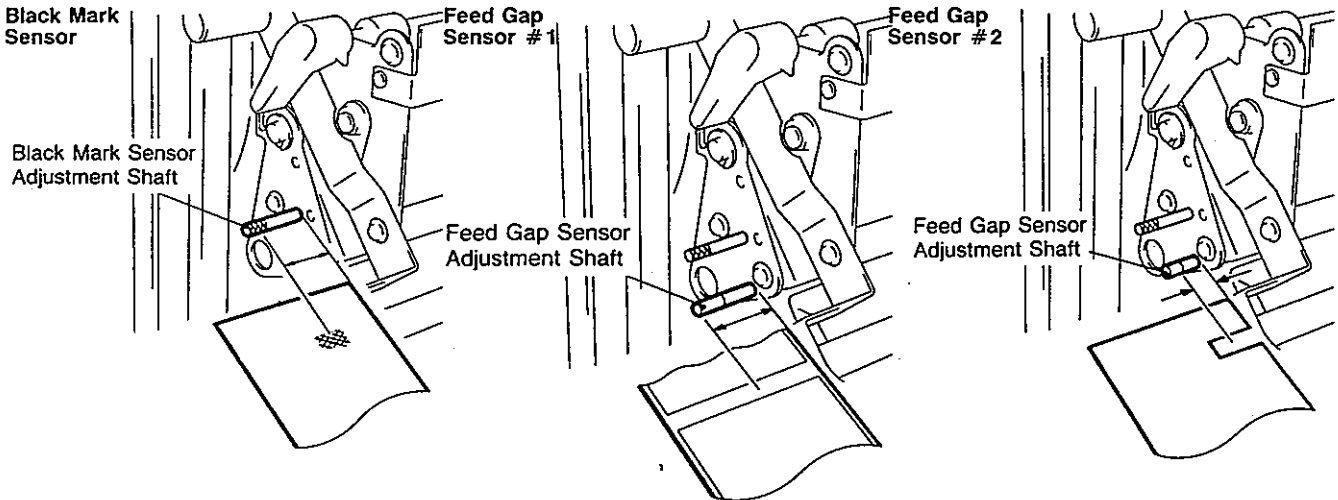

Figure 4-22.

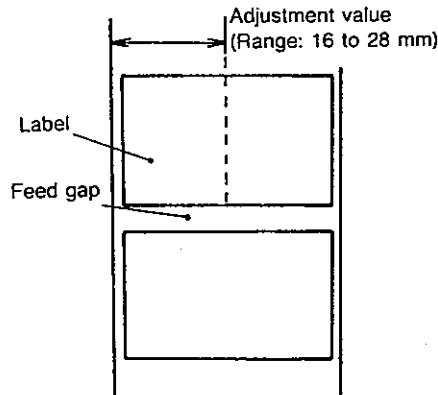

Figure 4-23.

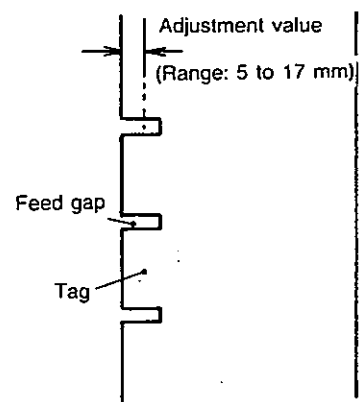

Figure 4-24.

**NOTICE:** Which sensor is used depends on the conditions of supply.

### 4.2. Label Issue Sensor (for On-demand type)

Adjust the position of the label issue sensor to the blank portion of the issued label (the portion where no characters are printed).

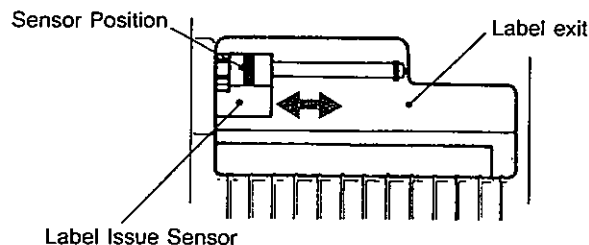

Figure 4-25.

## CHAPTER 5

### MAINTENANCE

1. REMOVING JAMMED SUPPLIES .....	5-1
1.1. For Standard Type .....	5-1
1.2. For On-demand Type.....	5-1
1.3. For Cutter Type.....	5-2
■ When the supply is exhausted .....	5-2
2. CLEANING THE PRINT HEAD .....	5-3
3. CLEANING THE CUTTER .....	5-4
4. TROUBLESHOOTING .....	5-5

## 1. REMOVING THE JAMMED SUPPLIES

### 1.1 For Standard Type

1. Open the front door.
2. Move the head lock lever to the right to release the print head.
3. Remove the supplies jammed inside.

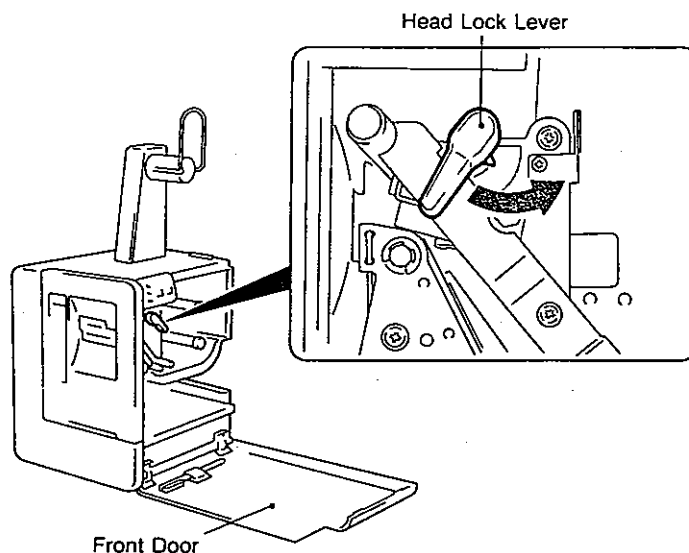

Figure 5-1.

### 1.2. For On-demand Type (for B-30-H1/H2 only)

1. Open the front door.
2. Move the head lock lever to the right to release the print head.
3. Turn and hold the backing roller lever, and pull the backing paper.

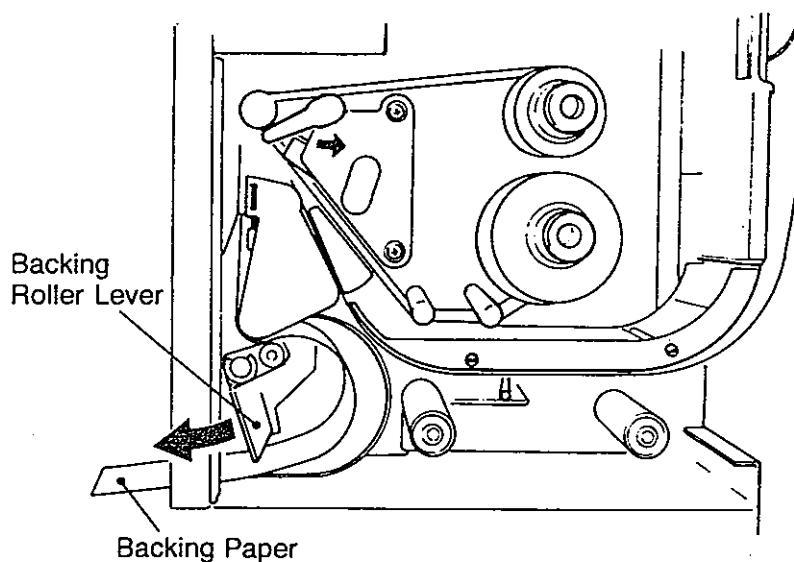

Figure 5-2.

### 1.3. For Cutter Type

1. Pull out the lock knob and adjustment knob.
2. Pull at the upper side of the cutter cover to remove it.

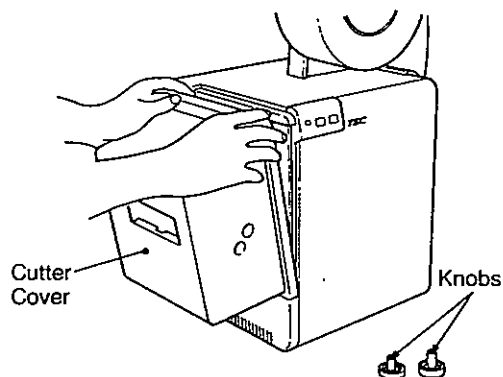

Figure 5-3.

3. Remove screw (A) to take out the supply guide cover, then remove the supplies jammed (blocking) inside.

**WARNING:** Turn the power off before removing jammed supplies.

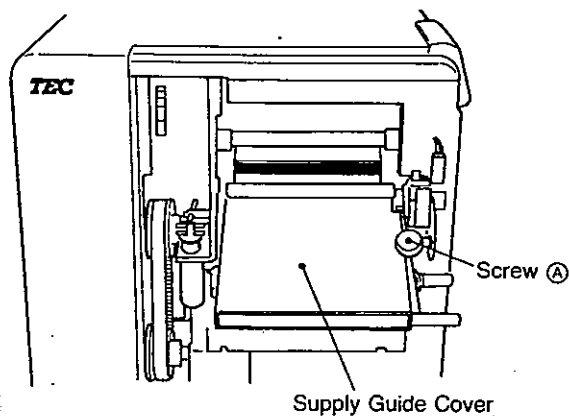

Figure 5-4.

#### ■ When the supply is exhausted

1. Depress the FEED key.
2. Pull out the piece of paper remaining in the cutter unit using tweezers.

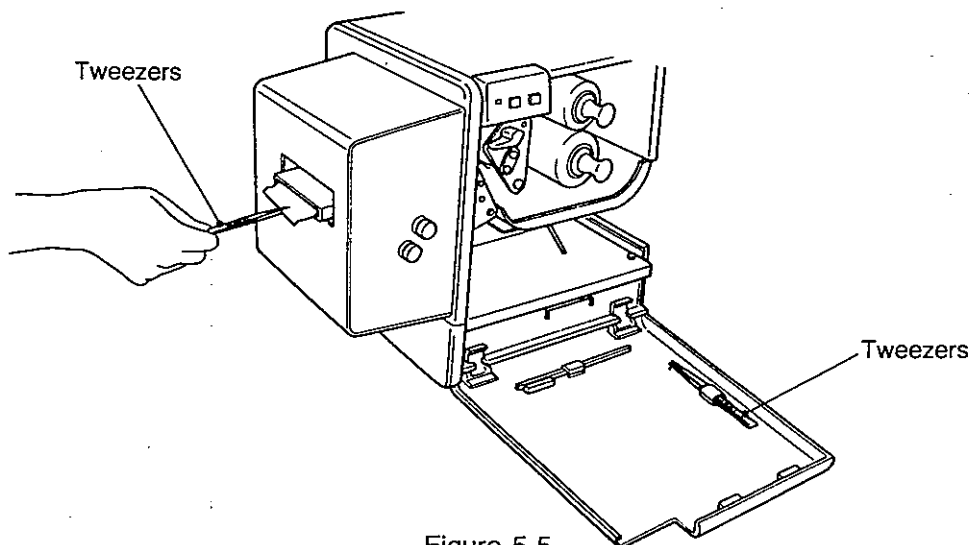

Figure 5-5.

## 2. CLEANING THE PRINT HEAD

If the print head is dirty, clear printing is not performed.

It is recommended to clean the head with thermal head cleaner before loading a new ribbon.

1. Turn the power off.
2. Open the front door.
3. Move the head lock lever to the right to release the print head.
4. Remove the ribbon if it has been loaded.
5. Move the supply back past the top of the paper guide.

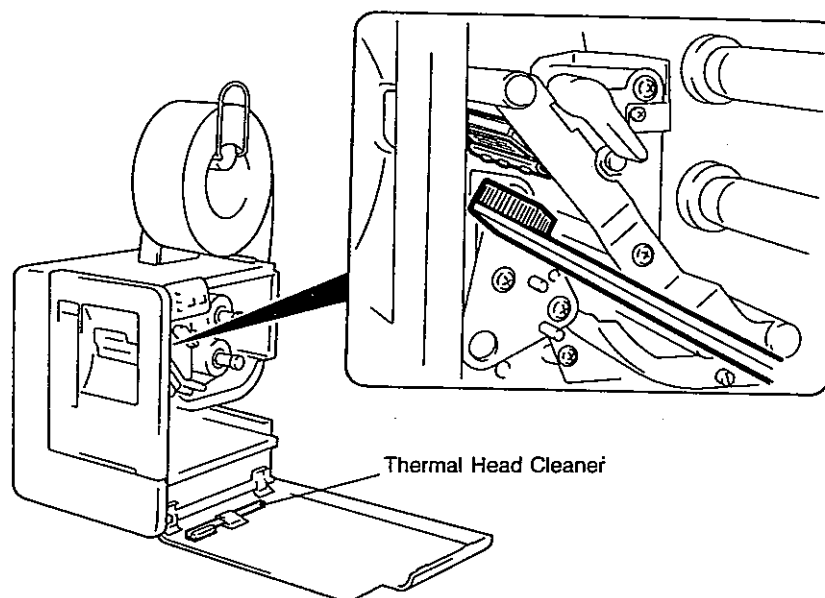

Figure 5-6.

6. Rub back and forth across the print head using thermal head cleaner.
7. Reload the supply and/or ribbon.

**WARNING:** Turn the power off before cleaning the print head.

**WARNING:** Be careful **NOT TO DAMAGE** the print head when cleaning.

### 3. CLEANING THE CUTTER

**WARNING:** Turn the power off before cleaning the cutter.

**WARNING:** Be extremely careful **NOT TO CUT** your fingers.

1. Pull out the lock knob and adjustment knob.
2. Pull the upper section of the cutter cover toward you to remove the cover.
3. Remove screws (A) to remove the supply guide cover.
4. Clean "dust" on the cutter with a soft cloth moistened with alcohol.

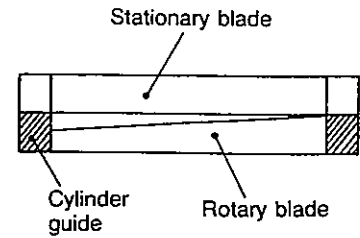

Figure 5-7.

**WARNING:** At this time, **DO NOT WIPE OFF** the cylinder guides (hatched parts) at both ends of the cutter.

5. If the rotating noise of the blade becomes particularly great, apply grease using a soft cloth. (Excessively applied grease may stain the supplies.) Grease should be applied to the rotary blade, stationary blade, and cylinder guides. For the cylinder guides (hatched parts), apply grease to their exposed parts so that grease spreads all around when the blade turns.

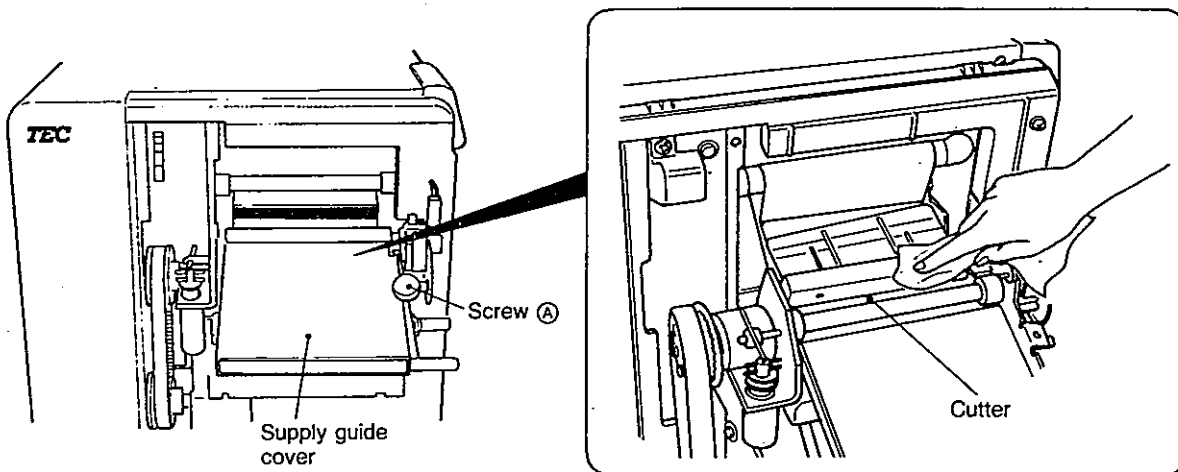

Figure 5-8.

#### ● Cutter Life

Observe raised nap on the cut end of the supply to determine whether the cutter has worn out. The life of a cutter largely varies according to the material, thickness, and kind of supply.

ex.)

Good

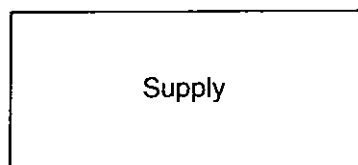

No good

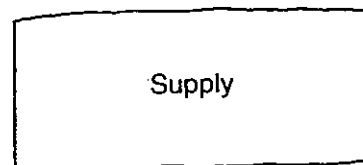

If the cut end of the supply is no longer straight as shown above, contact your TEC representative.

## 4. TROUBLESHOOTING

It is our primary concern to give you full satisfaction and better service. If, however, any problem arises in connection with the operation of this printer, please check the following points before you call for service.

Error Message	Problem	Solution
SENSOR OR LENGTH ERROR	<ol style="list-style-type: none"> <li>1. The paper is not placed correctly.</li> <li>2. The feeding paper is jammed and does not feed smoothly.</li> <li>3. The black mark or feed gap sensor position is incorrect.</li> <li>4. The combination of the issuing condition and paper or sensor does not match.</li> </ol>	<ol style="list-style-type: none"> <li>1. Place the paper correctly. → Press <b>PAUSE</b> key.</li> <li>2. Remove the jammed paper and place the undamaged paper correctly. → Press <b>PAUSE</b> key.</li> <li>3. Adjust the sensor position. → Press <b>PAUSE</b> key.</li> <li>4. Select the paper or sensor matching the issuing condition. → Press <b>PAUSE</b> key.</li> </ol>
NO PAPER	The supply ran out.	Load a new supply. → Press <b>PAUSE</b> key.
NO RIBBON	The ribbon ran out.	Load a new ribbon. → Press <b>PAUSE</b> key.
HEAD OPEN	When the print head is not set correctly, the supply tries to feed or issue.	Set the print head correctly. → Press <b>PAUSE</b> key.
CUTTER JAMMED (for Cutter type only)	<ol style="list-style-type: none"> <li>1. The paper is not cut correctly.</li> <li>2. The supply is jammed in the cutter unit.</li> </ol>	<ol style="list-style-type: none"> <li>1. Set the cutter at the home position. → Press <b>PAUSE</b> key.</li> <li>2. Open the cutter cover and remove the jammed (blocking) supply. → Press <b>PAUSE</b> key.</li> </ol>
CUTTER COVER OPEN (for Cutter type only)	<ol style="list-style-type: none"> <li>1. The cutter cover is not closed firmly.</li> <li>2. The cutter is not at the home position.</li> </ol>	<ol style="list-style-type: none"> <li>1. Close the cutter cover securely. → Press <b>PAUSE</b> key.</li> <li>2. Set the cutter at the home position. → Press <b>PAUSE</b> key.</li> </ol>
MISSING FEED KEY ERROR	After replacing with a new supply, the supply tries to issue one time without feeding.	Change the issuing condition for a new supply. → Turn off the power and then turn it on again.
COMMUNICATION ERROR (except for B-30-S1/H1/C1)	Error has occurred in communicating with a personal computer.	Turn off the power and then turn it on again.
<p><b>NOTE:</b> When an error is not cleared by pressing the <b>PAUSE</b> key, turn off the power and then turn it on again. When the power is turned on again, print data to be issued is cleared.</p>		

Problem	Solution
No print.	<ol style="list-style-type: none"> <li>1. Check whether the supply or ribbon is loaded correctly or not.</li> <li>2. Check whether the print head is set correctly or not.</li> <li>3. Check whether the memory card is inserted correctly or not.</li> <li>4. Check whether the interface cable is connected correctly or not.</li> </ol>
Printed characters are unclear (or blurred).	<ol style="list-style-type: none"> <li>1. Dirty print head. → Clean the print head.</li> <li>2. Bad ribbon. → Change to new ribbon.</li> <li>3. Wrong supply for printing. → Change to new supply.</li> </ol>
Power is not turned ON.	<ol style="list-style-type: none"> <li>1. Insert the power plug into the AC outlet firmly.</li> <li>2. Check the circuit breaker.</li> <li>3. Check whether the printer fuse is blown or not.</li> </ol>

This printer has been manufactured under strict quality control. If you have any trouble, however, DO NOT ATTEMPT TO FIX IT BY YOURSELF. Turn the power off, pull the power plug out of the AC outlet, and contact your TEC representative.



**TEC**  
**TOSHIBA TEC CORPORATION**

英文

 PRINTED IN JAPAN  
EM1-33004D.9404400 ①