REPLACEMENT PARTS MANUAL

ECONOMIZER

MODELS:

ECONWMT-T2B*, -T3B*, -T5B*
ECONWMT-E2B*, -E3B*, -E5B*
ECONWMS-E2B*, -E3B*, -E5B*

General Notes

- Revised and/or additional pages may be issued from time to time.
- A complete and current manual consists of pages shown in the following contents section.

Important

- Contact the installing and/or local distributor for all parts requirements. Make sure you have the complete model and serial number available from the unit rating plates.

Contents

Description	Page
Economizer & Control	
◆ Exploded View	2
◆ Usage List	3
◆ Usage List	4
◆ Exploded View	5
◆ Usage List	6
Economizer Air Hood	
◆ Exploded View	7
◆ Usage List	8
◆ Exploded View	9
◆ Usage List	10

BMC, Inc.
Bryan, Ohio 43506

Manual: 2110-697G
Supersedes: 2110-697F
File: Vol. III Tab 19
Date: 11-27-13

ECONOMIZER and CONTROL

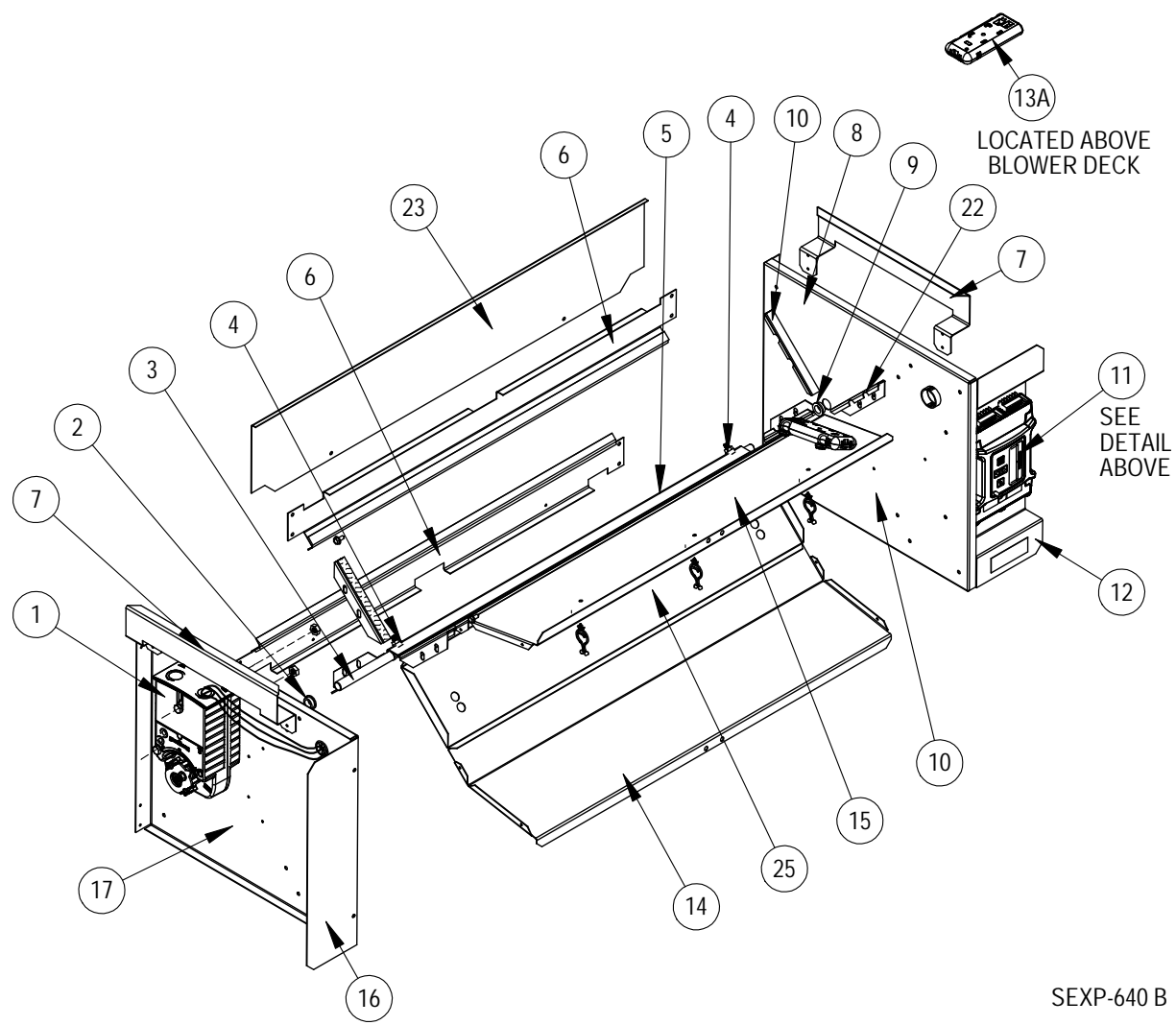
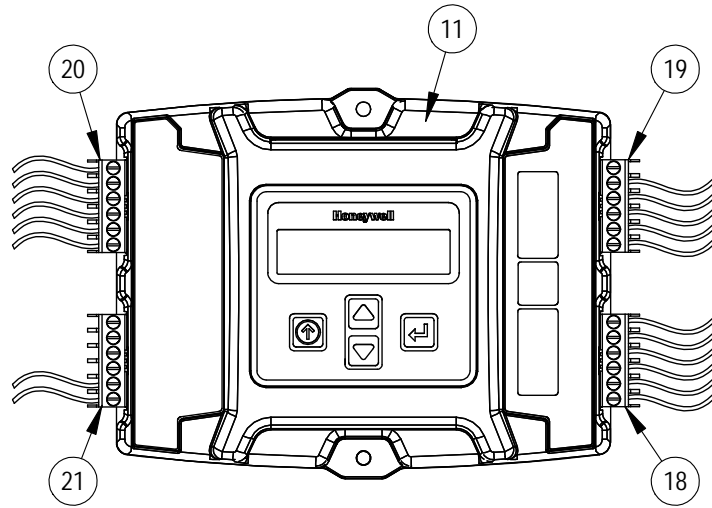

SEXP-640 B

ECONOMIZER and CONTROL

Drawing No.	Part No.	Description	ECONWMT-T2B	ECONWMT-E2B	ECONWMS-E2B
1	8602-059	Direct Coupled Actuator	X	X	X
2	8602-052	1/2" I.D. Bronze Bushing	X	X	X
3	8602-060	Drive Pin 1/2"	X	X	X
4	8602-038	Damper Pin with Hardware	2	2	2
5	S139-276	Damper Blade	X	X	X
6	105-1267	Rear Upper Angle	2	2	2
7	105-1266	Filter Angle	2	2	2
8	S101-627	Right Side	X	X	X
9	8602-039	Bronze Bushing	X	X	X
10	S105Y1248	Left Economizer Angle	4	4	4
11	S8602-056-0001A	Economizer Module - Programmed	X		
11	S8602-056-0002A	Economizer Module - Programmed		X	
11	S8602-056-0003A	Economizer Module - Programmed			X
12	S137-634	Right Fill Plate	X	X	X
13A	8602-058	Temperature Sensor - Mixed Air	X	X	X
14	127-414	Lower Partition/Base	X	X	X
15	121-461	Upper Partition	X	X	X
16	136-635	Left Fill Plate	X	X	X
17	S101-628	Left Side	X	X	X
18	3000-1417	Wire Harness	X	X	X
19	3000-1382	Wire Harness	X	X	X
20	3000-1383	Wire Harness	X		
20	3000-1395	Wire Harness		X	X
21	3000-1384	Wire Harness	X	X	X
22	S105X1248	Right Economizer Angle	X	X	X
23	105-1250	Return Fill	X	X	X
24	S105X1229	Right Economizer Angle	X	X	X
25	143-187	Block Off Plate	X	X	X
NS	S136-664	Condenser Cover Plate	X	X	X
NS	105-1277	Blade Angle	X	X	X
NS	8301-045	Temperature Sensor - Outdoor Air	X		
NS	910-1915	Enthalpy Sensor - Outdoor Air		X	X

Reference Drawing on Page 2

ECONOMIZER and CONTROL

Drawing No.	Part No.	Description	ECONWMT-T3B	ECONWMT-E3B	ECONWMS-E3B
1	8602-059	Direct Coupled Actuator	X	X	X
2	8602-052	1/2" I.D. Bronze Bushing	X	X	X
3	8602-060	Drive Pin 1/2"	X	X	X
4	8602-038	Damper Pin with Hardware	2	2	2
5	S139-261	Damper Blade	X	X	X
6	105-1244	Rear Upper Angle	2	2	2
7	105-1246	Filter Angle	2	2	2
8	S101-627	Right Side	X	X	X
9	8602-039	Bronze Bushing	X	X	X
10	S105Y1248	Left Economizer Angle	4	4	4
11	S8602-056-0001A	Economizer Module - Programmed	X		
11	S8602-056-0002A	Economizer Module - Programmed		X	
11	S8602-056-0003A	Economizer Module - Programmed			X
12	S137-634	Right Fill Plate	X	X	X
13A	8602-058	Temperature Sensor - Mixed Air	X	X	X
14	127-412	Lower Partition/Base	X	X	X
15	121-460	Upper Partition	X	X	X
16	136-635	Left Fill Plate	X	X	X
17	S101-628	Left Side	X	X	X
18	3000-1417	Wire Harness	X	X	X
19	3000-1382	Wire Harness	X	X	X
20	3000-1383	Wire Harness	X		
20	3000-1395	Wire Harness		X	X
21	3000-1384	Wire Harness	X	X	X
22	S105X1248	Right Economizer Angle	X	X	X
23	105-1250	Return Fill	X	X	X
24	S105X1229	Right Economizer Angle	X	X	X
25	143-188	Block Off Plate	X	X	X
NS	S136-653	Condenser Cover Plate	X	X	X
NS	105-1277	Blade Angle	X	X	X
NS	8301-045	Temperature Sensor - Outdoor Air	X		
NS	910-1915	Enthalpy Sensor - Outdoor Air		X	X

Reference Drawing on Page 2

ECONOMIZER and CONTROL

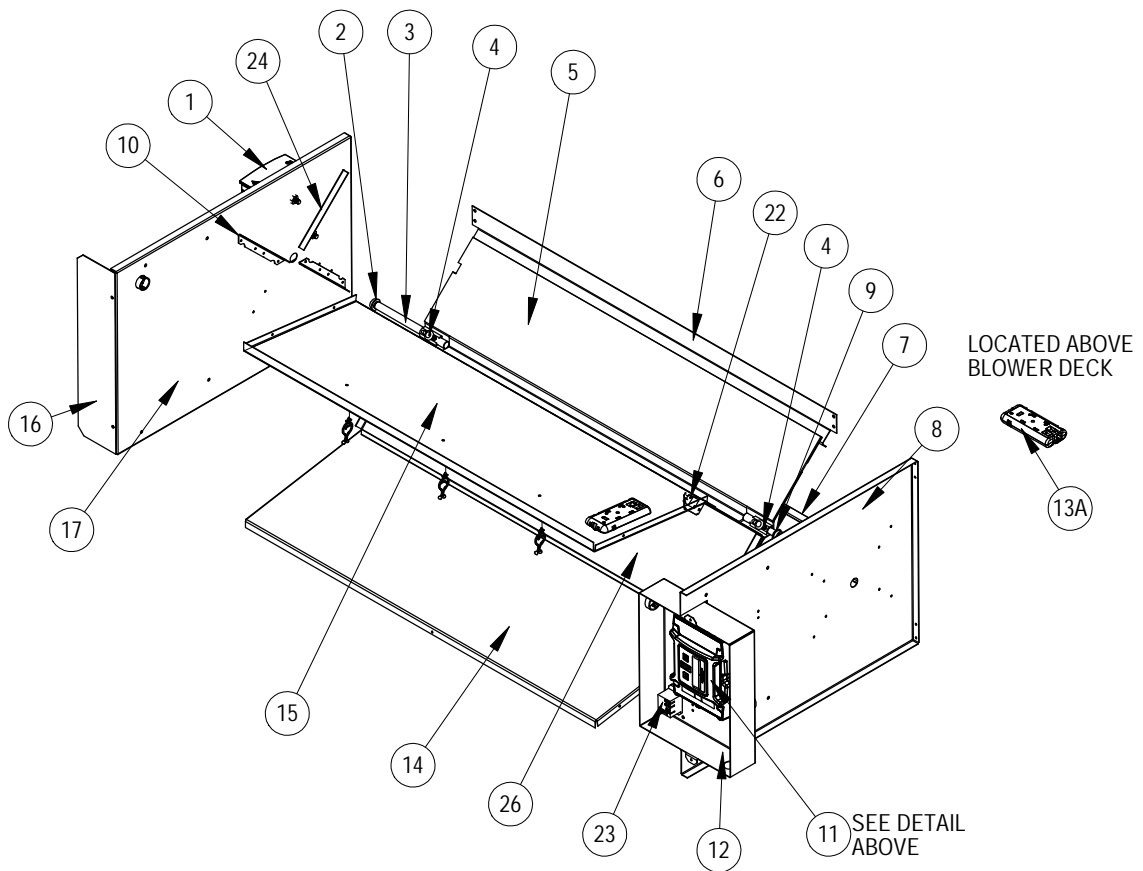
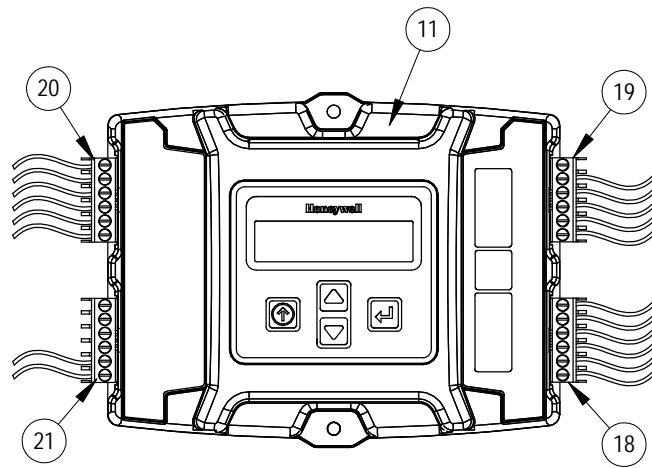

SEXP-613 E

ECONOMIZER and CONTROL

Drawing No.	Part No.	Description	ECONWMT-T5B	ECONWMT-E5B	ECONWMS-E5B
1	8602-059	Direct Coupled Actuator	X	X	X
2	8602-052	1/2" I.D. Bronze Bushing	X	X	X
3	8602-060	Drive Pin 1/2"	X	X	X
4	8602-038	Damper Pin with Hardware	2	2	2
5	S139-239	Damper Blade	X	X	X
6	105-1231	Rear Upper Angle	X	X	X
7	105-1230	Rear Lower Angle	X	X	X
8	S101-683	Right Side	X	X	X
9	8602-039	Bronze Bushing	X	X	X
10	S105Y1229	Left Economizer Angle	4	4	4
11	S8602-056-0001A	Economizer Module - Programmed	X		
11	S8602-056-0002A	Economizer Module - Programmed		X	
11	S8602-056-0003A	Economizer Module - Programmed			X
12	S137-666	Right Fill Plate	X	X	X
13	8602-063	Enthalpy Sensor - Outdoor Air	X	X	X
13A	8602-058	Temperature Sensor - Mixed Air	X	X	X
14	127-394	Lower Partition/Base	X	X	X
15	137-611	Upper Partition	X	X	X
16	137-613	Left Fill Plate	X	X	X
17	S101-606	Left Side	X	X	X
18	3000-1381	Wire Harness	X	X	X
19	3000-1382	Wire Harness	X	X	X
20	3000-1383	Wire Harness	X		
20	3000-1395	Wire Harness		X	X
21	3000-1384	Wire Harness	X	X	X
22	8406-133	Blade Switch	X	X	
23	8201-130	Relay	X	X	
24	S105X1229	Right Economizer Angle	X	X	X
26	143-186	Block Off Plate	X	X	X
NS	S136-632	Condenser Cover Plate	X	X	X
NS	8301-045	Temperature Sensor - Outdoor Air	X		

Reference Drawing on Page 2

ECONOMIZER AIR HOOD

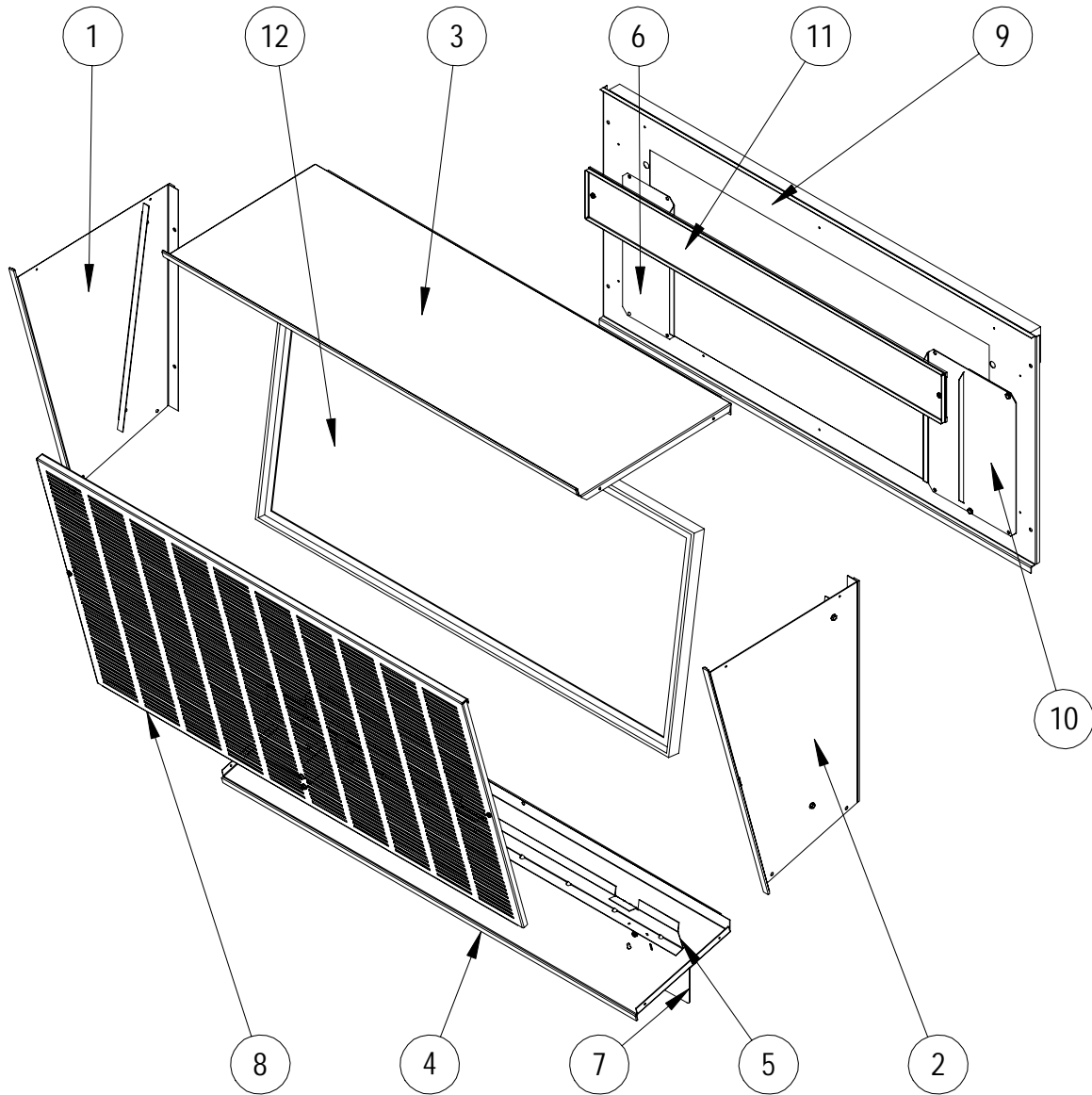

SEXP-675

ECONOMIZER AIR HOOD

Reference Drawing on Page 7

			ECONWMT-T2B HOOD ECONWMT-E2B HOOD	ECONWMT-T3B HOOD ECONWMT-E3B HOOD	ECONWMT-T5B HOOD ECONWMT-E5B HOOD
1	S101-777-* ①	Right Side			X
1	S101-746-* ①	Right Side	X	X	
1	S101-793 ②	Right Side			X
1	S101-801 ②	Right Side	X	X	
1	S101-797 ③	Right Side	X	X	
1	S101-795 ③	Right Side			X
2	S101-778-* ①	Left Side			X
2	S101-747-* ①	Left Side	X	X	
2	S101-794 ②	Left Side			X
2	S101-802 ②	Left Side	X	X	
2	S101-798 ③	Left Side	X	X	
2	S101-796 ③	Left Side			X
3	S107-328-* ①	Hood Top			X
3	S107-323-* ①	Hood Top	X		
3	S107-324-* ①	Hood Top		X	
3	S107-330 ②	Hood Top			X
3	S107-340 ②	Hood Top	X		
3	S107-339 ②	Hood Top		X	X
3	S107-338 ③	Hood Top	X		
3	S107-337 ③	Hood Top		X	
3	S107-335 ③	Hood Top			X
4	S127-449-* ①	Hood Bottom			X
4	S127-447-* ①	Hood Bottom	X		
4	S127-448-* ①	Hood Bottom		X	
4	S127-458 ②	Hood Bottom			X
4	S127-464 ②	Hood Bottom	X		
4	S127-463 ②	Hood Bottom		X	
4	S127-462 ③	Hood Bottom	X		
4	S127-461 ③	Hood Bottom		X	
4	S127-459 ③	Hood Bottom			X
5	113-494	Bottom Fill Bracket			X
5	113-488	Bottom Fill Bracket	X		
5	113-490	Bottom Fill Bracket		X	
5	113-500 ②	Bottom Fill Bracket			X
5	113-510 ②	Bottom Fill Bracket	X		
5	113-509 ②	Bottom Fill Bracket		X	
5	113-508 ③	Bottom Fill Bracket	X		
5	113-504 ③	Bottom Fill Bracket		X	
5	113-502 ③	Bottom Fill Bracket			X

① Exterior cabinet parts are manufactured with various paint color options. To ensure that you receive the proper paint color, you must include the complete model and serial number of the unit for which cabinet parts are being ordered.

② Note: Exterior cabinet parts are manufactured from stainless steel Code "S"

③ Note: Exterior cabinet parts are manufactured from aluminum Code "A"

NS = Not Shown

Continued on Page 9

ECONOMIZER AIR HOOD

Reference Drawing on Page 7

			ECONWMT-T2B HOOD ECONWMT-E2B HOOD	ECONWMT-T3B HOOD ECONWMT-E3B HOOD	ECONWMT-T5B HOOD ECONWMT-E5B HOOD
6	133-241				X
6	132-239		X	X	
6	133-246	②			X
6	133-250	②	X	X	
6	132-249	③	X	X	
6	133-248	③			X
7	113-484*	①			X
7	113-501	②			X
7	113-503	③			X
8	S115-259*	①			X
8	S115-244*	①	X		
8	S115-245*	①		X	
8	S115-265	②			X
8	S115-271	②	X		
8	S115-270	②		X	
8	S115-269	③	X		
8	S115-267	③		X	
8	S115-266	③			X
9	S153-570*	①			X
9	S153-566*	①	X		
9	S153-568*	①		X	
9	S153-579	②			X
9	S153-588	②	X		
9	S153-587	②		X	
9	S153-585	③	X		
9	S153-582	③		X	
9	S153-580	③			X
10	133-240				X
10	132-239		2	2	
10	133-245	②			X
10	133-250	②	2	2	
10	132-247	③			X
10	133-249	③	2	2	
11	S153-564				X
11	S153-567		X		
11	S153-569			X	
11	S153-578	②			X
11	S153-589	②	X		
11	S153-586	②		X	
11	S153-584	③	X		
11	S153-583	③		X	
11	S153-581	③			X
12	7003-067		X		
12	7003-066			X	
12	7003-062				X
NS	553-593	④		X	
NS	553-594	④	X		

① Exterior cabinet parts are manufactured with various paint color options. To ensure that you receive the proper paint color, you must include the complete model and serial number of the unit for which cabinet parts are being ordered.

② Note: Exterior cabinet parts are manufactured from stainless steel Code "S"

③ Note: Exterior cabinet parts are manufactured from aluminum Code "A"

④ Note: Fill Plate is used on R-22 Unit installations only. See Serial Plate for refrigeration information.

NS = Not Shown

Continued from Page 8

ECONOMIZER AIR HOOD

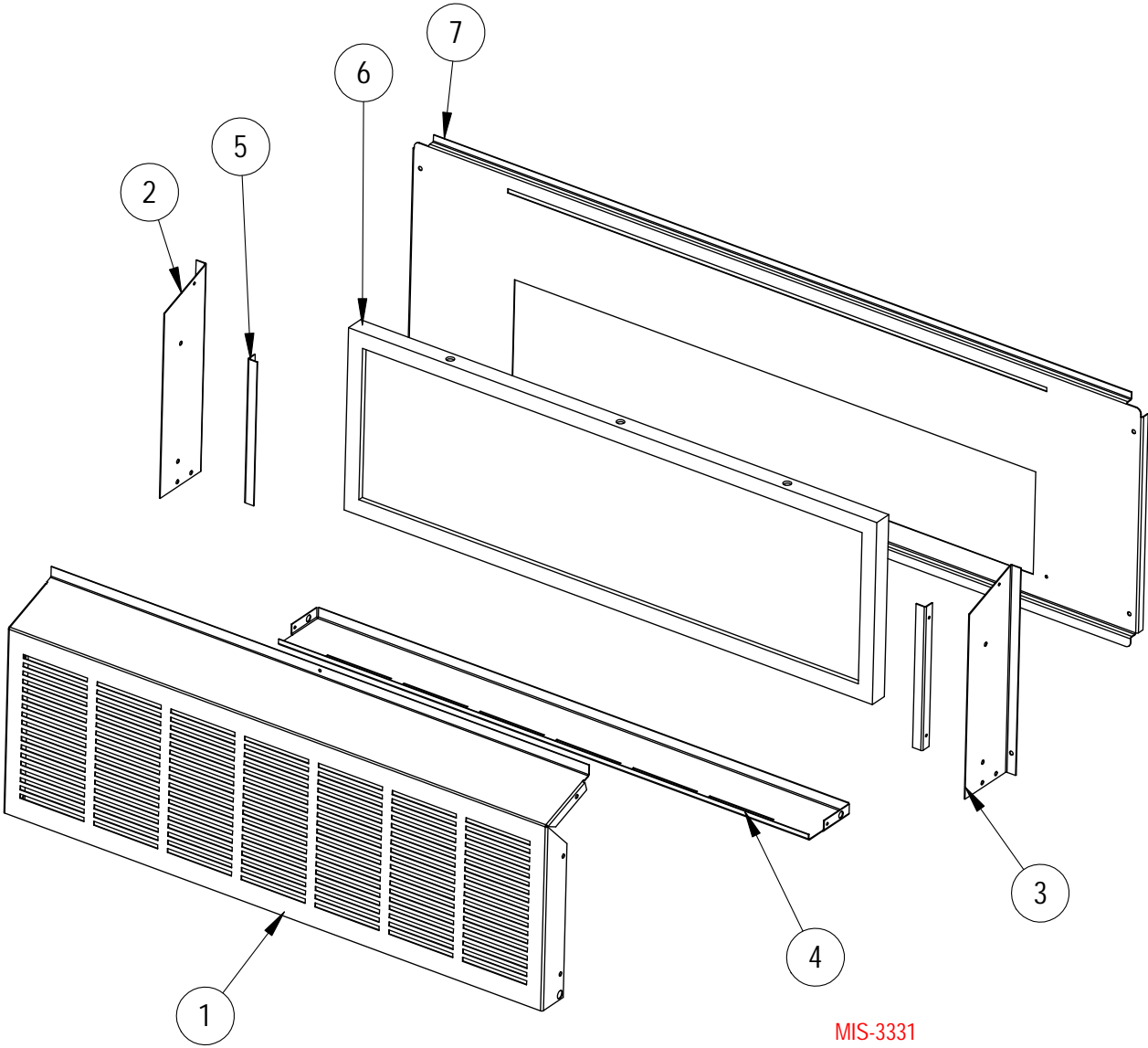

ECONOMIZER AIR HOOD

Reference Drawing on Page 10

Drawing No.	Part No.	Description	ECONWMS-E2B	ECONWMS-E3B	ECONWMS-E5B
1	139-091-* ①	Fresh Air Wrapper	X		
1	139-076-* ①	Fresh Air Wrapper		X	
1	139-186-* ①	Fresh Air Wrapper			X
1	139-304 ②	Fresh Air Wrapper	X		
1	139-307 ②	Fresh Air Wrapper		X	
1	139-309 ②	Fresh Air Wrapper			X
1	139-314 ③	Fresh Air Wrapper	X		
1	139-317 ③	Fresh Air Wrapper		X	
1	139-319 ③	Fresh Air Wrapper			X
2	S139-080-* ①	Left Fresh Air End	X	X	
2	S139-189-* ①	Left Fresh Air End			X
2	S139-306 ②	Left Fresh Air End	X	X	
2	S139-312 ②	Left Fresh Air End			X
2	S139-316 ③	Left Fresh Air End	X	X	
2	S139-322 ③	Left Fresh Air End			X
3	S139-078-* ①	Right Fresh Air End	X	X	
3	S139-188-* ①	Right Fresh Air End			X
3	S139-303 ②	Right Fresh Air End	X	X	
3	S139-311 ②	Right Fresh Air End			X
3	S139-313 ③	Right Fresh Air End	X	X	
3	S139-321 ③	Right Fresh Air End			X
4	S139-092-* ①	Fresh Air Bottom	X		
4	S139-077-* ①	Fresh Air Bottom		X	
4	S139-187-* ①	Fresh Air Bottom			X
4	S139-305 ②	Fresh Air Bottom	X		
4	S139-308 ②	Fresh Air Bottom		X	
4	S139-310 ②	Fresh Air Bottom			X
4	S139-315 ③	Fresh Air Bottom	X		
4	S139-318 ③	Fresh Air Bottom		X	
4	S139-320 ③	Fresh Air Bottom			X
5	105-202-*	Fresh Air Angle	2	2	
5	105-1178	Fresh Air Angle			2
5	105-1323 ②	Fresh Air Angle	2	2	
5	105-1325 ②	Fresh Air Angle			2
5	105-1326 ③	Fresh Air Angle	2	2	
5	105-1327 ③	Fresh Air Angle			2
6	7003-034	Mist Filter 8 $\frac{7}{8}$ x 22 $\frac{5}{8}$ x 1	X		
6	7003-033	Mist Filter 8 $\frac{7}{8}$ x 27 $\frac{5}{8}$ x 1		X	
6	7003-061	Mist Filter 12 x 32 $\frac{5}{8}$ x 1			X
7	S552-539-* ①	Vent Option Door Assy. (ERV)	X		
7	S552-540-* ①	Vent Option Door Assy. (ERV)		X	
7	S553-529-* ①	Vent Option Door Assy. (ERV)			X
7	S553-555 ②	Vent Option Door Assy. (ERV)	X		
7	S553-557 ②	Vent Option Door Assy. (ERV)		X	
7	S553-591 ②	Vent Option Door Assy. (ERV)			X
7	S553-556 ③	Vent Option Door Assy. (ERV)	X		
7	S553-558 ③	Vent Option Door Assy. (ERV)		X	
7	S553-590 ③	Vent Option Door Assy. (ERV)			X
NS	WMDK2-*	Rain Hood & Door Complete 2-Ton	X		
NS	WMDK3-*	Rain Hood & Door Complete 3-Ton		X	
NS	WMDK5-*	Rain Hood & Door Complete 5-Ton			X

① Exterior cabinet parts are manufactured with various paint color options. To ensure that you receive the proper paint color, you must include the complete model and serial number of the unit for which cabinet parts are being ordered.

② Note: Exterior cabinet parts are manufactured from stainless steel Code "S"

③ Note: Exterior cabinet parts are manufactured from aluminum Code "A"

NS = Not Shown