

### FEATURED MODEL

511-969 10" & 6" bowl depths

### FEATURES

- 18 gauge, 304 series stainless steel
- 18/10 chrome/nickel content
- Long-lasting, easy-to-clean, satin polished finish
- Straight bowl sides with 5/8" cutout corner radius
- Rear drain placement

### CODE/STANDARDS COMPLIANCE

ASME 112.19.3-00

IAPMO/UPC listed

### OPTIONAL ACCESSORIES

Sink Grid: 510-902

Colanders: 215-651

### WARRANTY

Blanco America's Platinum Series sinks feature a "NO HASSLE" LIMITED LIFETIME WARRANTY to be free of all manufacturing defects under normal use. See our complete warranty for details.

While Blanco America endeavors to provide accurate information, all dimensions are nominal, cannot be guaranteed, and are subject to change or cancellation. Blanco America assumes no responsibility for use of superseded or voided specifications.

### PRODUCT SPECIFICATION

Drop-In sink to be 1-1/2 bowl design, 26-1/2" in length and 22" in front-to-back depth. Sink to be made from 18 gauge, 304 series stainless steel, with 18/10 chrome/nickel content and satin polished finish. Sink to feature rear drain placement and straight bowl sides with 5/8" cutout corner radius. Sink to be Blanco Model 511-969, with large bowl depth of 10" and small bowl depth of 6". Additional knockout hole locations: \_\_\_\_\_



### NOMINAL DIMENSIONS

MODEL 511-969

MODEL	OVERALL	CUTOUT SIZE	BOWL DEPTH LEFT	BOWL DEPTH RIGHT	DRAIN DIAMETER
511-969	26-1/2 x 22	25-3/4 x 20-3/8	10	6	3-1/2

DXF cutout templates available on our web site or this specification CD.

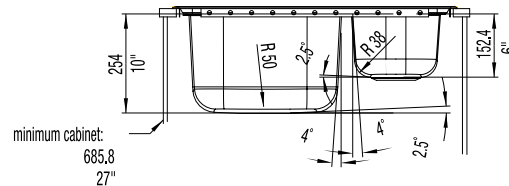
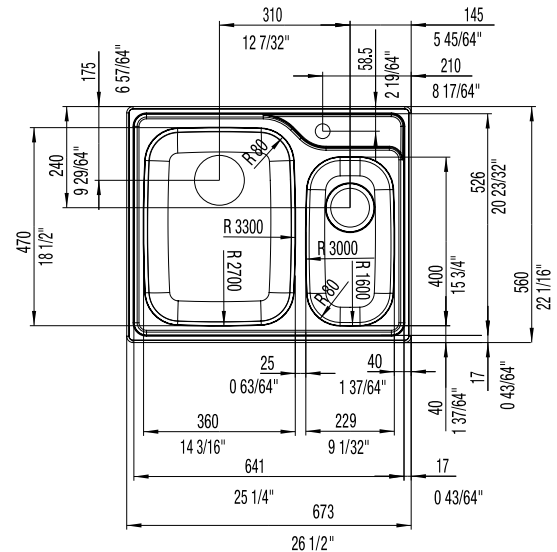

### JOB INFORMATION

Job Name: \_\_\_\_\_

Contact: \_\_\_\_\_

Date Specified: \_\_\_\_\_

Specifier: \_\_\_\_\_

Contractor: \_\_\_\_\_

### KNOCKOUT HOLE LOCATIONS

Pre-drilled for single-hole faucet.

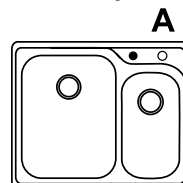

**BLANCO AMERICA**  
**800.451.5782**  
**www.blancoamerica.com**

© 2006 BLANCO AMERICA

05/06

SPEC-003