



METROLOGIC INSTRUMENTS, INC.
IS4220 ScanGlove®
Laser Bar Code Scanner
Installation and User's Guide





LOCATIONS

CORPORATE HEADQUARTERS NORTH AMERICA

USA, NEW JERSEY

Metrologic Instruments, Inc.
Tel: 1-800-ID-METRO Fax: 856-228-6673
Email: info@metrologic.com

SOUTH AMERICA, BRAZIL SÃO PAULO

Metrologic do Brasil Ltda.
Tel: 55-11-5182-8226 Fax: 55-11-5182-8315
Email: info@br.metrologic.com

SOUTH AMERICA, OUTSIDE BRAZIL SÃO PAULO

Metrologic South America
Tel: 55-11-5182-7273 Fax: 55-11-5182-7198
Email: info@sa.metrologic.com

ASIA, SINGAPORE

Metrologic Asia (Pte) Ltd
Tel: 65-6842-7155 Fax: 65-6842-7166
Email: info@sg.metrologic.com

CHINA, SUZHOU

Metro Technologies Co., Ltd.
Tel: 86-512-62572511 Fax: 86-512-62571517
Email: info@cn.metrologic.com

Metro Sales Office

Tel: 86-512-67622550 Fax: 86-512-67622560
Email: info@cn.metrologic.com

JAPAN, TOKYO

Metrologic Japan Co., Ltd.
Tel: 81-03-3839-8511 Fax: 81-03-3839-8519
Email: info@jp.metrologic.com

EUROPEAN, MIDDLE EAST & AFRICAN HEADQUARTERS

GERMANY, MUNICH

Metrologic Instruments GmbH
Tel: 49-89-89019-0 Fax: 49-89-89019-200
Email: info@europe.metrologic.com

GERMANY, MUNICH

Metrologic Instruments GmbH
Tel: 49-89-89019-0 Fax: 49-89-89019-200
Email: info@de.metrologic.com

ITALY, BOLOGNA

Metrologic Instruments Italia srl
Tel: +39 0 51 6511978 Fax: +39 0 51 6521337
Email: info@it.metrologic.com

FRANCE, PARIS

Metrologic Eria France SA
Tel: +33 (0) 1 48.63.78.78
Fax: +33 (0) 1 48.63.24.94
Email: info@fr.metrologic.com

SPAIN, MADRID

Metrologic Eria Ibérica, SL
Tel: +34 913 272 400 Fax: +34 913 273 829
Email: info@es.metrologic.com

Metrologic Europe Repair Center (MERC)

Metrologic Eria Ibérica, SL
Tel: +34 913 751 249 Fax: +34 913 270 437

UNITED KINGDOM, BASINGSTOKE

Metrologic Instruments UK Limited
Tel: +44 (0) 1256 365900
Fax: +44 (0) 1256 365955
Email: info@uk.metrologic.com

RUSSIA, MOSCOW

Metrologic Russia
Tel: +7 095 730 7424 Fax: +7 095 730 7425
Email: info@ru.metrologic.com

Copyright

© 2004 by Metrologic Instruments, Inc. All rights reserved. No part of this work may be reproduced, transmitted, or stored in any form or by any means without prior written consent, except by reviewer, who may quote brief passages in a review, or provided for in the Copyright Act of 1976.

Products and brand names mentioned in this document are trademarks of their respective companies.

TABLE OF CONTENTS

Introduction	1
Scanner and Accessories	1
Scanner Installation.....	2
Scanner Configuration to the Host System	3
Parts of the Scanner	4
Visual Indicators	5
Audible Indicators.....	9
Labels.....	10
Maintenance.....	10
Infrared (IR) Object Sensor	11
Scan Field	12
Specifications	13
Default Settings.....	14
Troubleshooting Guide.....	19
Limited Warranty.....	20
Notices	21
Patents	23
Index.....	24

INTRODUCTION

The IS4220 ScanGlove® is a fully automatic single-line laser barcode scanner. It is designed to be used as a “hands-free” wearable scanner or a stationary desktop scanner.

Every ScanGlove is equipped with ScanQuest®, a patented activation technology that allows the scanner to read bar codes automatically as the operator presents the bar code to the scanner. Additional features include; 52 scan lines a second, short or long range activation and two universal glove sizes with left and right-hand capabilities.

The IS4220 has built in decoding for applications that use a RS232, Keyboard Wedge, Stand Alone Keyboard, Light Pen Emulation, or USB communication interface. For additional information on other system interfaces call please call a Metrologic Customer Service Representative at 1-800-ID-METRO.

SCANGLOVE MODEL NO.	INTERFACE
IS4220-07	USB Keyboard
IS4220-08	USB POS
IS4220-14	RS232
IS4220-15	Light Pen Emulation
IS4220-17	PC Keyboard Wedge and Stand Alone Keyboard
IS4220-41	Full RS232 and Light Pen Emulation

SCANNER AND ACCESSORIES

PART NUMBER	DESCRIPTION
IS4220	IS4220 Laser Scanner
00-02348	Installation and User's Guide
00-02343	Programming Guide
00-02044	Programming Addendum (USB Models Only)
45-45455	Black Adjustable Glove

If any item is missing or to order additional items, contact the dealer, distributor or call Metrologic's Customer Service Department at 1-800-ID-METRO or 1-800-436-3876.

SCANNER INSTALLATION

1. Turn off power to the host system.
2. Connect the communication cable to the proper port on the host device.
3. Turn on power to the host system.



When the IS4220 first receives power, the red LED will flash, the green LED will flash, and then the scanner will beep once.



Caution:

To maintain compliance with applicable standards, all circuits connected to the scanner must meet the requirements for SELV (Safety Extra Low Voltage) according to EN 60950.

To maintain compliance with standard CSA C22.2 No. 950/UL 1950 and norm EN 60950, the power source should meet applicable performance requirements for a limited power source.

To maintain compliance with federal regulations 21 CFR, Part 1040.10, section (f)(6) the scanner must be plugged into an electrical outlet with a switch accessible to the user or be powered by a host system containing a switch that will disable power to the scanner.

SCANNER CONFIGURATION TO THE HOST SYSTEM

The IS4220 is shipped from the factory pre-programmed to a set of default parameters. It may be necessary to change the default parameters to match the host system's requirements or to enable additional scanner functions. For a list of possible parameter settings, refer to the *Default Settings* section of this guide.



Important notes for the -07 and -08, IS4220 USB Interfaces.

The IS4220-07 and the IS4220-08 are pre-programmed for USB Emulation before leaving the factory. If the recall defaults bar code is scanned the unit must be re-programmed for USB Emulation before enabling or disabling any additional features documented in the programming guide (MLPN 00-02343).

To re-program the unit for USB Keyboard Emulation or USB POS Emulation refer to the IS4220 USB Addendum (MLPN 00-02044) for the IS4220 Programming Guide.

To modify the scanner's default parameters follow the steps below using the bar codes located in the programming guide (MLPN 00-02343).

1. Scan the ENTER PROGRAM MODE bar code to enter programming mode. The scanner will beep three times.
2. Scan the bar code(s) for the desired parameter(s). The scanner will beep once.
3. Scan the EXIT PROGRAM MODE bar code to exit and save the new parameter settings. The scanner will beep three times.



If during programming there is a need to return the scanner to the original factory settings, scan the recall defaults bar code in the programming guide. All settings selected during that session or any previous sessions are discarded when you scan the recall defaults code.

Please read the warning above for the IS4220-07 and -08 models before using the recall defaults bar code.

PARTS OF THE SCANNER

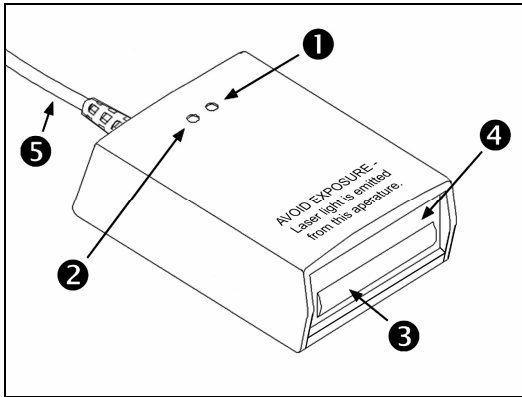

Figure 1. Scanner Parts

Item No.	Description
①	Green LED When a bar code is read successfully the green LED will flash.
②	Red LED When the red LED is illuminated, the laser is on.
③	Red Output Window (Laser Aperture)
④	Infrared Sensor (IR) If a specified time has elapsed without any scanning, the unit will enter a “standby” mode. To reactivate the unit, place an object in front of the IR sensor. The red LED will turn on when the scanner is ready to scan.
⑤	Communication/Power Cable This cable’s termination is application dependent.

VISUAL INDICATORS

There is a red and a green LED located on the top of the scanner. When the scanner is on, the flashing or constant illumination of the LEDs indicates the status of the current scan and the scanner.

No Red LED	Illumination of the LEDs will not occur if the scanner has remained dormant for a specified time and the scanner is not receiving power from the host. To reactivate the unit, direct the output window up then down toward the object.
Red Flash; Green Flash; Steady Red	When the scanner <i>first</i> receives power, the red LED will flash, followed by the green LED, and then the unit will beep once. The red LED will stay on after it flashes once.
Steady Red	When the laser is on, the red LED will be on. This occurs when an object is detected in the scan field. If the scanner cannot detect a bar code within approximately 2.5 seconds, the unit will go into a standby mode and the red LED will shut off indicating that the laser is no longer on.
Steady Red LED; Green Flash	When the scanner successfully reads a bar code, the green LED will flash and the unit will beep once. If the green LED does not flash or the scanner does not beep, then the bar code was <i>not</i> successfully read.
Repetitive Red LED Flashing	When the red LED flashes several times while it rests upon a stationary surface, then an object is within the scan field and is activating the IR sensor repetitively. To eliminate this disturbance, direct the scan window toward a different location.
Steady Green LED	After a successful scan, the scanner transmits the data to the host device. When the host is not ready to receive the information, the green LED will remain on until data can transmit.

SIGNAUX OPTIQUES

Sur la partie supérieure du scanner se trouvent une diode LED rouge et une diode LED verte. Quand le scanner est sous tension, les diodes rouge et verte clignotantes ou allumées vous informent sur l'état de palpage et de scanner.

Ni la diode rouge, ni la diode verte n'est allumée

Il existe deux raisons possibles pour que les diodes ne s'allument pas. Si le scanner ne reçoit pas d'énergie de l'ordinateur PC, les diodes ne s'allument pas. Quand le scanner reçoit de l'énergie et ne s'allume cependant pas, le scanner est resté pendant une certaine période sans être utilisé et le laser et le moteur sont désactivés. Pour réactiver l'unité, déplacer un objet devant le palpeur infrarouge ou prendre le scanner et diriger la fenêtre de palpage vers le bas.

Diode rouge clignotante; diode verte clignotante; diode rouge reste allumée

Quand le scanner reçoit *pour la première fois* de l'énergie, la diode rouge se met d'abord à clignoter, puis la diode verte. Ensuite, le scanner émet un bip sonore unique. Une fois cette séquence de démarrage effectuée, la diode rouge reste allumée pendant un certain temps indiquant que le laser est en service. Quand le scanner ne détecte aucun objet, la diode rouge et le laser s'éteignent.

Diode rouge reste allumée

Quand le laser est activé, la diode rouge s'allume également. C'est par exemple le cas quand un objet se trouve devant la fenêtre de palpage. Si, en l'espace de 2, 5 secondes, aucun code barres n'est détecté, la diode rouge s'éteint, ce qui signifie que le laser est désactivé.

Diode rouge reste allumée; diode verte clignotante

Après lecture *avec succès* d'un code barres par le scanner, la diode verte se met à clignoter, suivie d'un bip sonore unique. Si la diode verte ne clignote pas ou quand aucun bip sonore n'est émis, cela signifie que le code barres *n'a pas* pu être lu avec succès.

Clignotement répété de la diode rouge

Quand la diode rouge clignote plusieurs fois pendant que l'appareil repose sur une surface non déplacée, un objet activant le palpeur infrarouge se trouve devant la fenêtre de palpage. Ceci peut se produire même quand le scanner se trouve sur une table ou un reposoir. Pour éliminer ce défaut, positionner le scanner de façon différente.

Diode verte reste allumée

Une fois le palpage effectué *avec succès*, le scanner transmet les données à l'ordinateur PC. Si ce dernier n'est pas prêt à recevoir les données, la diode verte du scanner s'allume jusqu'à ce que les données puissent être transmises.

OPTISCHE ANZEIGEN

Auf der Oberseite des Scanners befinden sich eine rote und eine grüne Leuchtdiodenanzeige. Ist der Scanner eingeschaltet, so geben Ihnen die blinkenden oder feststehenden Leuchtdiodenanzeigen Aufschluß über den Abtast und Scannerstatus.

**Weder rote
oder noch
grüne
Leuchtanzeige**

Es gibt zwei mögliche Gründe, weshalb die Leuchtdiodenanzeigen nicht aufleuchten. Bekommt der Scanner keine Energie vom PC, leuchten die Leuchtdiodenanzeigen nicht auf. Wenn der Scanner jedoch Energie bekommt und die Leuchtdiodenanzeigen dennoch nicht aufleuchten, so ist der Scanner für einen bestimmten Zeitraum untätig geblieben, und Laser und Motor sind abgeschaltet. Zur Reaktivierung der Einheit sollten Sie ein Objekt vor dem Infrarot Sensor hin und herbewegen oder den Scanner aufnehmen und das Abtastfenster nach unten richten.

**Rote
Blinkanzeige;
Grüne
Blinkanzeige;
feststehende
grüne
Leuchtanzeige**

Wenn dem Scanner *erstmalig* Energie zugeführt wird, blinkt zunächst die rote Leuchtdiodenanzeige auf, gefolgt von der grünen Leuchtdiodenanzeige, und anschließend sendet der Scanner ein einmaliges Piep-Signal aus. Nach Ausführung dieser Startsequenz leuchtet die rote Leuchtdiodenanzeige für einen bestimmten Zeitraum auf und zeigt an, daß der Laser eingeschaltet ist. Wird dem Scanner kein Objekt präsentiert, so schalten sich die rote Leuchtdiode und der Laser ab.

**Feststehende
rote
Leuchtanzeige**

Wenn der Laser eingeschaltet ist, leuchtet auch die rote Leuchtdiodenanzeige auf. Dies ist dann der Fall, wenn sich ein Objekt im Abtastfeld befindet. Wird innerhalb von ca. 2,5 Sekunden kein Barcode erfaßt, so erlischt die rote Leuchtdiodenanzeige, was bedeutet, daß der Laser nicht mehr eingeschaltet ist.

**Feststehende
rote
Leuchtanzeige;
grüne
Blinkanzeige**

Nach *erfolgreichem* Lesen eines Barcodes durch den Scanner blinkt die grüne Leuchtdiodenanzeige auf, gefolgt von einem einmaligen Piep-Signal. Falls die grüne Leuchtdiodenanzeige nicht aufblinkt oder der Scanner kein einmaliges Piep-Signal aussendet, bedeutet dies, daß der Barcode *nicht* erfolgreich gelesen werden konnte.

**Wiederholte
rote
Blinkanzeigen**

Blinkt die rote Leuchtdiodenanzeige mehrmals auf, während das Gerät auf einer nichtbewegten Fläche liegt, so befindet sich ein Objekt inner halb des Abtastfeldes, das den Infrarot-Sensor aktiviert. Dies kann selbst dann vorkommen, wenn der Scanner auf dem Ladentisch oder dem Ablagegestell liegt. Um diese Störung zu beseitigen, sollten Sie den Scanner anders positionieren.

**Feststehende
grüne
Leuchtanzeige**

Nach *erfolgreichem* Abtasten überträgt der Scanner die Daten an den PC. Ist der PC nicht zur Annahme der Daten bereit, so leuchtet die grüne Leuchtdiodenanzeige des Scanners solange auf, bis die Daten übertragen werden können.

SEGNALI OTTICI

Sulla parte superiore dello scanner si trovano due diodi luminosi: uno rosso e uno verde. Quando lo scanner è inserito, i diodi luminosi, che possono o essere accesi in continuazione o lampeggiare, Vi informano sullo stato della scansione e dell'apparecchio.

Né il diodo luminoso rosso né quello verde sono accesi

Vi sono due possibili cause se i diodi luminosi non sono accesi. Se lo scanner non viene alimentato dal PC i diodi luminosi non sono accesi. Se invece lo scanner è alimentato e ciononostante i diodi luminosi non sono accesi, lo scanner è rimasto disattivato per un determinato periodo e laser e motore sono spenti. Per riattivare l'unità dovrete muovere un oggetto davanti al sensore a infrarossi oppure prendere lo scanner e rivolgere il finestrino di scansione verso il basso.

Il diodo luminoso rosso lampeggia; il diodo luminoso verde lampeggia; il diodo luminoso verde è acceso

Quando lo scanner viene alimentato *per la prima volta*, lampeggia dapprima il diodo luminoso rosso e quindi quello verde. Poi lo scanner emette un unico segnale beep. Dopo l'esecuzione di questa sequenza di avvio il diodo luminoso rosso si accende per un determinato periodo ed indica che il laser è inserito. Se allo scanner non viene presentato nessun oggetto, il diodo luminoso rosso e il laser si spengono.

Il diodo luminoso rosso è acceso

Quando il laser è attivato, è acceso anche il diodo luminoso rosso. Questo si ha quando un oggetto si trova nella zona di scansione. Se entro ca. 2, 5 secondi non viene registrato nessun codice a barre, il diodo luminoso rosso si spegne; ciò significa che il laser non è più attivato.

Il diodo luminoso rosso è acceso; il diodo luminoso verde lampeggia

Dopo la lettura *riuscita* di un codice a barre da parte dello scanner il diodo luminoso verde lampeggia e quindi viene emesso un unico segnale beep. Se il diodo luminoso verde non lampeggia oppure lo scanner non emette un segnale beep, ciò significa che la lettura del codice a barre *non* è riuscita.

Il diodo luminoso verde è acceso

Dopo la scansione riuscita lo scanner trasmette i dati al PC. Se il PC non è pronto per accettare i dati, il diodo luminoso verde dello scanner è acceso fino a che i dati possono essere trasmessi.

Il diodo luminoso rosso lampeggia ripetutamente

Se il diodo luminoso rosso lampeggia ripetutamente mentre l'apparecchio si trova su una superficie che non si muove, vi è un oggetto all'interno della zona di scansione che attiva il sensore a infrarossi. Ciò può essere addirittura il caso quando lo scanner si trova sul banco oppure nel suo supporto. Per eliminare questa anomalia basta cambiare la posizione dello scanner.

AUDIBLE INDICATORS

The scanner provides sounds to signal certain conditions. To change the volume (four settings are available) or turn the beeper off, refer to *Beeper Tones* in the Programming Guide.

One Beep

When the scanner *first* receives power, the red LED will flash, followed by the green LED, and then the scanner will beep once. After the scanner performs this start-up sequence, the scanner is ready to scan.

When the scanner *successfully* reads a bar code, the green light will flash and the unit will beep once. If the green LED does not flash or the scanner does not beep, then the bar code read is *not* successful.

Razzberry Tone

If, upon power up, the scanner emits a razzberry tone the scanner has failed diagnostics.



The scanner can be programmed to emit a razzberry tone when the timeout occurs during communication between the host and scanner. Refer to *Audible Indicators for Communication Timeouts* the Programming Guide.

Three Beeps

When entering program mode, the green LED will flash three times while the scanner simultaneously beeps three times. When exiting program mode, the same visual and audible indications will occur. After this sequence is completed, the red LED will turn off.



The scanner can be programmed to emit three beeps when the timeout occurs during communication between the host and scanner. Refer to *Audible Indicators for Communication Timeouts* the Programming Guide.

LABELS

Each IS4220 has a serial number label and a laser class label on the bottom of the unit. These labels provide important information like; date and location of manufacture, model number, serial number, caution statements and laser class. There is also text molded into the top of the case near the window that says, "AVOID EXPOSURE - laser light emitted from this aperture". The following Figure shows examples of these labels*.

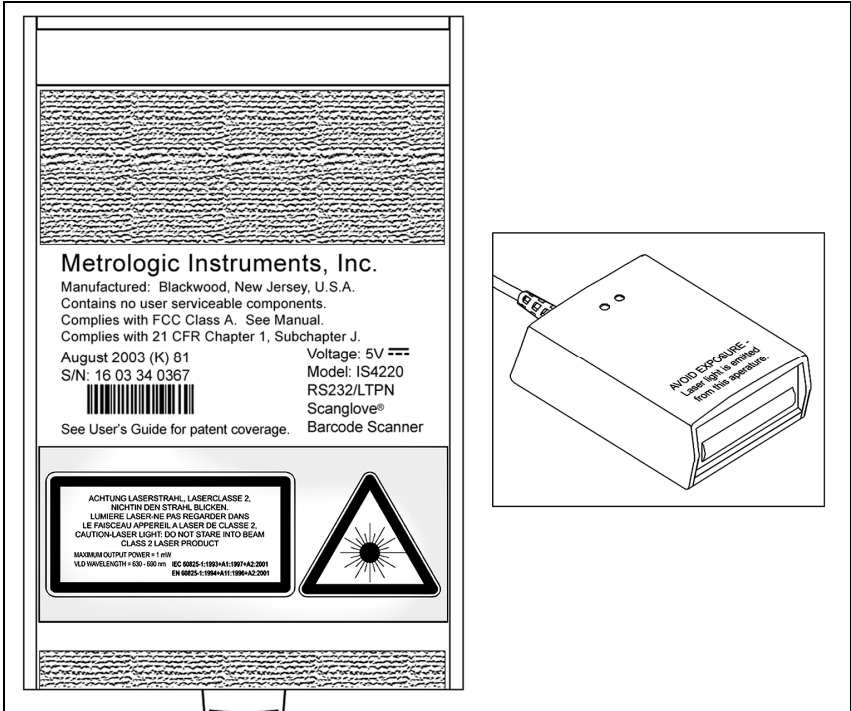

Figure 2. Caution and Serial Number Labels*

* Labels not shown to scale.

MAINTENANCE

Smudges and dirt can interfere with the proper scanning of a bar code. Therefore, the output window will need occasional cleaning.

1. Spray glass cleaner onto lint free, non-abrasive cleaning cloth.
2. Gently wipe the output window.

INFRARED (IR) OBJECT SENSOR

An infrared (IR) device located behind the window initiates the scanning process. The IR sensor is active as long as power is applied to the unit. When the IR sensor detects an object, the green LED will flash. When the laser decodes a bar code, the scanner transmits the data to the host system and emits a beep to show that decoding is complete. The IR sensor range can be programmed for two ranges.

Short Range Activation

The IR signal initiates the scan process if it senses an object anywhere from the face of the window out to approximately 4" to 7".

Long Range Activation

The IR signal initiates the scan process if it senses an object anywhere from the face of the window out to approximately 9" to 13".

If the object is removed from the field during the scanning process, the laser turns off and the scanner re-enters "standby" mode. However, *if the object stays in the field*, the laser remains on for up to 2.5 seconds trying to detect another bar code. If the scanner does not detect a bar code, the scanner re-enters "standby" mode. To reactivate the scanning sequence, remove the object and present another.

If the same symbol stays in the field after a successful scan, the laser stays on for approximately 7.5 seconds and then turns off. This prevents unintentional reads of the same bar code. To read the same symbol more than once, remove the object from the scan field for approximately 1 second and then present the symbol again.

Scan Field

The depth of field for the scanner is 12.7 mm to 203 mm (.5" to 8") from the face of the output window for .33 (13 mil) Bar Codes.

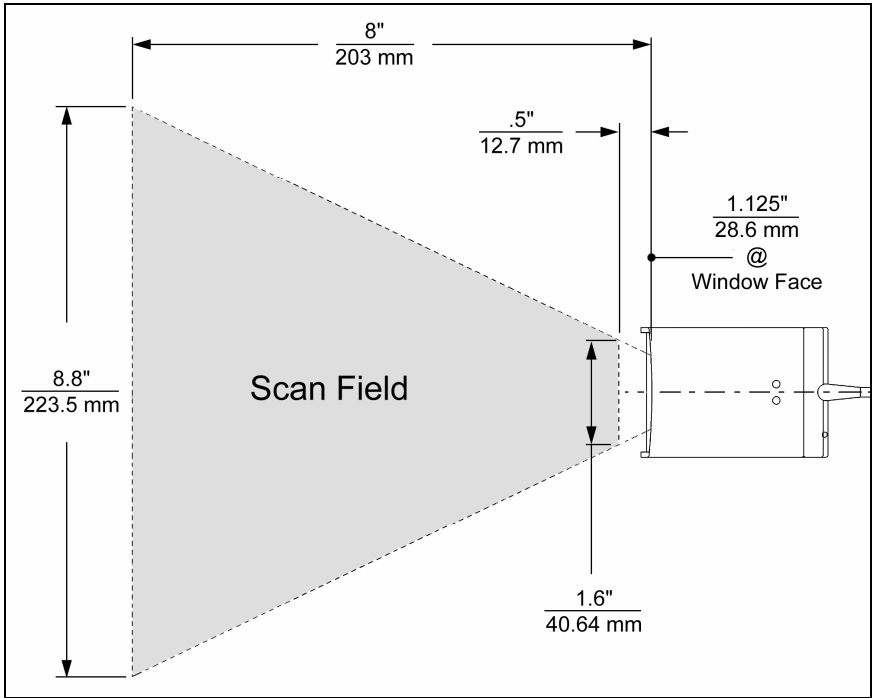

Figure 3. Scan Field for .33 (13 mil) Bar Codes

Specifications subject to change without notice.

SPECIFICATIONS

IS4220 SPECIFICATIONS	
OPERATIONAL	
Light Source:	650 nm VLD
Depth of Field:	12.7 mm to 203 mm (.5" to 8") for .33 (13 mil) bar code
Width of Scan Field:	28.6 mm (1.125") @ face; 102 mm (4") @ 76.2 mm (3")
Scan Speed:	52 scans lines per second
Scan Pattern:	Single scan line
Min Bar Width:	0.173 mm (6.8 mil)
Decode Capability:	Autodiscriminates all standard bar codes; for other symbologies call a Metrologic representative
System Interfaces:	RS232, Light Pen Emulation, PC Keyboard Wedge, Stand Alone Keyboard, USB (low speed)
Print Contrast:	35% minimum reflectance difference
Number of Characters Read:	up to 80 data characters (Maximum number will vary based on symbology and density)
Roll, Pitch, Yaw:	42°, 68°, 52°
Beeper Operation:	3 tones or no beep
Indicators (LED):	red = laser on, ready to scan green = good read, decoding
MECHANICAL	
Length x Width x Height:	70 mm x 49 mm x 24 mm (2.75" x 1.94" x 0.94")
Weight:	105 grams (3.7 oz.)
Cable Termination:	Application Dependent
ELECTRICAL	
Input Voltage:	5VDC ± 0.25V
Power:	0.75 W
Operating Current:	135 mA
DC Transformers:	Class 2; 5VDC @ 300 mA
Laser Class 2:	EN 60825-1:1993+A1:1997+A2:2001 EN 60825-1:1994+A11:1996+A2:2001
EMC:	FCC, ICES-003 & EN 55022 Class A
ENVIRONMENTAL	
Operating Temperature:	-20°C to 50°C (-4°F to 122°F)
Storage temperature:	-40°C to 70°C (-40°F to 158°F)
Humidity:	5% to 95% relative humidity, non-condensing
Light Levels:	Up to 4842 Lux (450 footcandles)
Shock:	Designed to withstand 1.5 m (5') drops
Contaminants:	Sealed to resist airborne particulate contaminants
Ventilation:	None required

Specifications subject to change without notice.

DEFAULT SETTINGS

Many functions of the scanner can be "programmed", that is enabled or disabled. The scanner is shipped from the factory programmed to a set of default conditions. All factory default parameters have an asterisk (*) in the default column of the charts on the following pages . If an asterisk is not in the default column then the setting is off or disabled by default. Every interface does not support every parameter. If the interface supports a parameter listed in the charts on the following pages, a check mark (✓) will appear.

PARAMETER	DEFAULT	RS232	LIGHT PEN	KEYBOARD WEDGE	USB
Enter Program Mode After Any Scan	*	✓	✓	✓	✓
Enter Program Mode Only on First Scan		✓	✓	✓	✓
Short Range Activation		✓	✓	✓	✓
Long Range Activation	*	✓	✓	✓	✓
Normal Scan	*	✓	✓	✓	✓
Pulsing Scan		✓	✓	✓	✓
Custom Scan		✓	✓	✓	✓
Short Same Symbol Rescan		✓	✓	✓	✓
Long Same Symbol Rescan	*	✓	✓	✓	✓
Alternate Beeper Tone 1		✓	✓	✓	✓
Alternate Beeper Tone 2	*	✓	✓	✓	✓
Alternate Beeper Tone 3		✓	✓	✓	✓
No Beeper Tone		✓	✓	✓	✓
Two Second Timeout		✓			✓
No Two Second Timeout	*	✓			✓
Razzberry Tone on Timeout		✓			✓
No Tone on Timeout	*	✓			✓
Three Beeps on Timeout		✓			✓
Beep Before Transmit	*	✓		✓	✓
Beep After Transmit		✓		✓	✓
Baud Rate	9600	✓			✓
Parity	Space	✓			✓
8 Data Bits		✓			✓
7 Data Bits	*	✓			✓
RTS/CTS		✓			
Character RTS/CTS	*	✓			
Message RTS/CTS		✓			

DEFAULT SETTINGS

PARAMETER	DEFAULT	RS232	LIGHT PEN	KEYBOARD WEDGE	USB
ACK/NAK		✓			
XON/XOFF	*	✓			
No Intercharacter Delay		✓		✓	✓
1 Millisecond Intercharacter Delay		✓		✓	✓
5 Millisecond Intercharacter Delay		✓			✓
10 Millisecond Intercharacter Delay				✓	
25 Millisecond Intercharacter Delay		✓			✓
100 Millisecond Intercharacter Delay				✓	
DTR Input		✓			
DTR Scan Disable		✓			
“DE” Disable Command		✓			
LRC Calc+ Transmit RS232		✓			
Start LRC on first RS232 Byte		✓			
Start LRC on Second RS232 Byte	*	✓			
Carriage Return	*	✓		✓	✓
Line Feed	*	✓		✓	✓
STX Prefix		✓		✓	✓
ETX Suffix		✓		✓	✓
Tab Prefix		✓		✓	✓
Tab Suffix		✓		✓	✓
Prefix ID for UPC/EAN		✓		✓	✓
Suffix ID for UPC/EAN		✓		✓	✓
Bars High	*		✓		
Spaces High			✓		
Transmit as Scanned	*		✓		
Transmit as Code 39			✓		
Poll Light Pen 5 Volts			✓		
No Poll Light Pen	*		✓		
Reverse Polarity Idle for Light Pen			✓		
UPC	*	✓	✓	✓	✓
EAN	*	✓	✓	✓	✓
Full ASCII code 39		✓	✓	✓	✓
Code 39	*	✓	✓	✓	✓
Codabar		✓	✓	✓	✓
Code 128	*	✓	✓	✓	✓
Code 93	*	✓	✓	✓	✓
Interleaved 2 of 5 (ITF)	*	✓	✓	✓	✓
Code 11		✓	✓	✓	✓

DEFAULT SETTINGS

PARAMETER	DEFAULT	RS232	LIGHT PEN	KEYBOARD WEDGE	USB
Hong Kong Matrix 2 of 5		✓	✓	✓	✓
Airline 2 of 5		✓	✓	✓	✓
Minimum 1 Character Code Length		✓	✓	✓	✓
Minimum 3 Character Code Length	*	✓	✓	✓	✓
Minimum 6 Character Code Length		✓	✓	✓	✓
Set Minimum Character Length		✓	✓	✓	✓
Set Character Lock Length		✓	✓	✓	✓
Transmit UPC-A Number Sys	*	✓	✓	✓	✓
UPC-A Check Digit Transmit	*	✓	✓	✓	✓
Convert UPC-A to EAN-13		✓		✓	✓
Expand UPC-E		✓		✓	✓
UPC-E Check Digit Transmit		✓		✓	✓
UPC-E Leading 0 Transmit		✓		✓	✓
EAN-8 Check Digit Transmit	*	✓	✓	✓	✓
EAN-13 Check Digit Transmit		✓	✓	✓	✓
Convert EAN-8 to EAN-13		✓	✓	✓	✓
“\$” Prefix ID for UPC/EAN		✓	✓		✓
2 Digit Supps (Scan)		✓	✓	✓	✓
5 Digit Supps (Scan)		✓	✓	✓	✓
Bookland (Scan)		✓	✓	✓	✓
Supplement Required		✓	✓	✓	✓
Bookland to ISBN		✓	✓	✓	✓
Transmit ISBN CD		✓	✓	✓	✓
Mod 43 Check Digit Code 39		✓	✓	✓	✓
Transmit Mod 43 Check Digit Code 39	*	✓	✓	✓	✓
Transmit Start/Stop Code 39		✓	✓	✓	✓
CLSI Editing (Enable)		✓	✓	✓	✓
ITF Check Digit		✓	✓	✓	✓
Transmit MOD 10 ITF Check Digit		✓	✓	✓	✓
I 2 of 5 Symbol Lengths	Variable	✓	✓	✓	✓
ISBN Reformatting		✓			✓
Coupon Code 128		✓	✓	✓	✓

DEFAULT SETTINGS

PARAMETER	DEFAULT	RS232	LIGHT PEN	KEYBOARD WEDGE	USB
JC1 Transmit Coupon C128		✓	✓	✓	✓
Coupon 128 Group Separator		✓	✓	✓	✓
Italian Pharmaceutical		✓	✓	✓	✓
Codabar Start and Stop Class		✓	✓	✓	✓
ITF Minimum Symbol Length Test		✓	✓	✓	✓
Matrix 2 of 5 Check Digit		✓	✓	✓	✓
Hong Kong Matrix 2 of 5		✓	✓	✓	✓
MSI - Plessey Test of Check Digit	*	✓	✓	✓	✓
Enable MSI - Plessey Mod 10 Check Digit		✓	✓	✓	✓
Enable MSI - Plessey Mod 10/10 Check Digit				✓	
Transmit MSI - Plessey Check Digit	*	✓	✓	✓	✓
UK Plessey		✓	✓	✓	✓
UK Plessey Check Digit		✓	✓	✓	✓
UK Plessey Special Format		✓	✓	✓	✓
A to X conversion (UK)		✓	✓	✓	✓
Scan Count Test Mode		✓		✓	✓
Scanability Test Mode		✓		✓	✓
Normal Scan/Operating Test Mode		✓		✓	✓
Transmit Scanner Parameters Test Mode		✓		✓	✓
Code ID				✓	
Sanyo 635 ECR Protocol		✓			✓
Post Software ID Characters		✓		✓	✓
"Newcode" Mode A		✓		✓	✓
"Newcode" Mode B		✓		✓	✓
BIO DATA Mode		✓			✓
Golden Bountiful Formatting		✓			✓
Intermec Polling Mode D (limited function)		✓			✓
Enable Sineko Mode		✓			✓
Enable Caps Lock Mode (for MI951 keyboard wedge)		✓			✓
Enable French Wyse 120 PC Term		✓			✓
Rochford Tompson Mode		✓		✓	✓

DEFAULT SETTINGS

PARAMETER	DEFAULT	RS232	LIGHT PEN	KEYBOARD WEDGE	USB
RTS Counter Toggle		✓			✓
Beep on BEL RS232		✓			✓
Banconer Mode		✓			✓
FedEX parsing		✓			✓
Retransmit of Same Code		✓		✓	✓
1 st Programmable Prefix ID		✓		✓	✓
2 nd Programmable Prefix ID		✓		✓	✓
1 st Programmable Suffix ID		✓		✓	✓
2 nd Programmable Suffix ID		✓		✓	✓
Clear all Programmable Prefixes and Suffixes		✓		✓	✓
SNI Beetle Mode		✓		✓	✓
ATKeyboard	*			✓	
Type XT Keyboard				✓	
Type PS2 Keyboard				✓	
USA Keyboard	*			✓	
Belgium Keyboard				✓	
France Keyboard				✓	
Germany Keyboard				✓	
Spain Keyboard				✓	
Italy Keyboard				✓	
UK Keyboard				✓	
IBM KDB4700 Financial Keyboard				✓	
Alt Mode				✓	
Auto Detection or Caps Lock				✓	
User-Defined Caps Lock				✓	
F0H Break Code Transmission	*			✓	
800 Microsecond Delay-Enter Scan Code	*			✓	
15 Millisecond Delay-Enter Scan Code				✓	
7-5 Millisecond Delay-Enter Scan Code				✓	

TROUBLESHOOTING GUIDE

The following guide is for reference purposes only. Contact a Metrologic representative at 1-800-ID-METRO or 1-800-436-3876 to preserve the limited warranty terms on page 20.

SYMPTOMS	POSSIBLE CAUSE(S)	SOLUTION
No LEDs, beep and there is no visible laser	No Power is being supplied to the scanner	Make sure the cable is plugged into the host. Check the host system's power cable, the outlet and power strip.
No LEDs, beep and there is no visible laser	No power is being supplied from the USB port.	The IS4220 requests 100mA from the USB port. If the USB port cannot supply this, a notification window will appear on the screen.
After scanning a bar code, the Red and Green LEDs are on, but no data is being transmitted to the host.	The scanner is not programmed properly for communication with the host.	Re-program the scanner using the appropriate codes for your scanner model.
USB Keyboard Emulation		
After scanning a bar code, the scanner beeps, but the characters appear incorrectly in your application.	The scanner is not programmed correctly. The incorrect country has been selected.	Re-program the scanner using the appropriate codes for your scanner model.
The scanner powers up, but does not scan and/or beep.	The scanner is trying to scan a particular bar code symbology that is not enabled	Verify that the type of bar code being read is enabled.

LIMITED WARRANTY

The IS4220 ScanGlove® scanners are manufactured by Metrologic at its Blackwood, New Jersey, U.S.A. facility. The IS4220 scanners have a two (2) year limited warranty from the date of manufacture. Metrologic warrants and represents that all IS4220 scanners are free of all defects in material, workmanship and design, and have been produced and labeled in compliance with all applicable U.S. Federal, state and local laws, regulations and ordinances pertaining to their production and labeling.

This warranty is limited to repair, replacement of Product or refund of Product price at the sole discretion of Metrologic. Faulty equipment must be returned to the Metrologic facility in Blackwood, New Jersey, U.S.A. or Puchheim, Germany. To do this, contact Metrologic's Customer Service/Repair Department to obtain a Returned Material Authorization (RMA) number.

In the event that it is determined the equipment failure is covered under this warranty, Metrologic shall, at its sole option, repair the Product or replace the Product with a functionally equivalent unit and return such repaired or replaced Product without charge for service or return freight, whether distributor, dealer/reseller, or retail consumer, or refund an amount equal to the original purchase price.

This limited warranty does not extend to any Product which, in the sole judgement of Metrologic, has been subjected to abuse, misuse, neglect, improper installation or accident, nor any damage due to use or misuse produced from integration of the Product into any mechanical, electrical or computer system. The warranty is void if the case of Product is opened by anyone other than Metrologic's repair department or authorized repair centers.

THIS LIMITED WARRANTY, EXCEPT AS TO TITLE, IS IN LIEU OF ALL OTHER WARRANTIES OR GUARANTEES, EITHER EXPRESS OR IMPLIED, AND SPECIFICALLY EXCLUDES, WITHOUT LIMITATION, WARRANTIES OF MERCHANTABILITY AND FITNESS FOR A PARTICULAR PURPOSE UNDER THE UNIFORM COMMERCIAL CODE, OR ARISING OUT OF CUSTOM OR CONDUCT. THE AND REMEDIES PROVIDED HEREIN ARE EXCLUSIVE AND IN LIEU OF ANY OTHER RIGHTS OR REMEDIES. IN NO EVENT SHALL METROLOGIC BE LIABLE FOR ANY INDIRECT OR CONSEQUENTIAL DAMAGES, INCIDENTAL DAMAGES, DAMAGES TO PERSON OR PROPERTY, OR EFFECT ON BUSINESS OR PROPERTY, OR OTHER DAMAGES OR EXPENSES DUE DIRECTLY OR INDIRECTLY TO THE PRODUCT, EXCEPT AS STATED IN THIS WARRANTY. IN NO EVENT SHALL ANY LIABILITY OF METROLOGIC EXCEED THE ACTUAL AMOUNT PAID TO METROLOGIC FOR THE PRODUCT. METROLOGIC RESERVES THE RIGHT TO MAKE ANY CHANGES TO THE PRODUCT DESCRIBED HEREIN.

CORPORATE HEADQUARTERS

Metrologic Instruments, Inc.
90 Coles Road
Blackwood, NJ 08012-4683

Customer Service: 1-800-ID-METRO
Tel: 856-228-8100
Fax: 856-228-6673
Email: info@metrologic.com
Website: www.metrologic.com

GERMANY

Metrologic Instruments GmbH
Dornierstrasse 2
82178 Puchheim b.
Munich, Germany

Tel: 49-89-89019-0
Fax: 49-89-89019-200
Email: info@europe.metrologic.com

NOTICES

Notice

This equipment has been tested and found to comply with limits for a Class A digital device, pursuant to part 15 of the FCC Rules. These limits are designed to provide reasonable protection against harmful interference when the equipment is operated in a commercial environment. This equipment generates, uses and can radiate radio frequency energy and, if not installed and used in accordance with the instruction manual, may cause harmful interference to radio communications. Operation of this equipment in a residential area is likely to cause harmful interference, in which case the user will be required to correct the interference at his own expense. Any unauthorized changes or modifications to this equipment could void the user's authority to operate this device.

This device complies with part 15 of the FCC Rules. Operation is subject to the following two conditions: (1) This device may not cause harmful interference, and (2) this device must accept any interference received, including interference that may cause undesired operation.

Notice

This Class A digital apparatus complies with Canadian ICES-003.

Remarque

Cet appareil numérique de la classe A est conforme à la norme NMB-003 du Canada.

Caution

Use of controls or adjustments or performance of procedures other than those specified herein may result in hazardous laser light exposure. Under no circumstances should the customer attempt to service the laser scanner. Never attempt to look at the laser beam, even if the scanner appears to be nonfunctional. Never open the scanner in an attempt to look into the device. Doing so could result in hazardous laser light exposure. The use of optical instruments with the laser equipment will increase eye hazard.

Atención

La modificación de los procedimientos, o la utilización de controles o ajustes distintos de los especificados aquí, pueden provocar una luz de láser peligrosa. Bajo ninguna circunstancia el usuario deberá realizar el mantenimiento del láser del escáner. Ni intentar mirar al haz del láser incluso cuando este no esté operativo. Tampoco deberá abrir el escáner para examinar el aparato. El hacerlo puede conllevar una exposición peligrosa a la luz de láser. El uso de instrumentos ópticos con el equipo láser puede incrementar el riesgo para la vista.

Attention

L'emploi de commandes, réglages ou procédés autres que ceux décrits ici peut entraîner de graves irradiations. Le client ne doit en aucun cas essayer d'entretenir lui-même le scanner ou le laser. Ne regardez jamais directement le rayon laser, même si vous croyez que le scanner est inactif. N'ouvrez jamais le scanner pour regarder dans l'appareil. Ce faisant, vous vous exposez à une rayonnement laser qui est dangereux. L'emploi d'appareils optiques avec cet équipement laser augmente le risque d'endommagement de la vision.

Achtung

Die Verwendung anderer als der hier beschriebenen Steuerungen, Einstellungen oder Verfahren kann eine gefährliche Laserstrahlung hervorrufen. Der Kunde sollte unter keinen Umständen versuchen, den Laser-Scanner selbst zu warten. Sehen Sie niemals in den Laserstrahl, selbst wenn Sie glauben, daß der Scanner nicht aktiv ist. Öffnen Sie niemals den Scanner, um in das Gerät hineinzusehen. Wenn Sie dies tun, können Sie sich einer gefährlichen Laserstrahlung aussetzen. Der Einsatz optischer Geräte mit dieser Laserausrüstung erhöht das Risiko einer Sehschädigung.

Attenzione

L'utilizzo di sistemi di controllo, di regolazioni o di procedimenti diversi da quelli descritti nel presente Manuale può provocare delle esposizioni a raggi laser rischiose. Il cliente non deve assolutamente tentare di riparare egli stesso lo scanner laser. Non guardate mai il raggio laser, anche se credete che lo scanner non sia attivo. Non aprite mai lo scanner per guardare dentro l'apparecchio. Facendolo potete esporvi ad una esposizione laser rischiosa. L'uso di apparecchi ottici, equipaggiati con raggi laser, aumenta il rischio di danni alla vista.

NOTICES

European Standard

Warning

This is a class A product. In a domestic environment this product may cause radio interference in which case the user may be required to take adequate measures.

Funkstöreigenschaften nach EN 55022:1998

Warnung!

Dies ist eine Einrichtung der Klasse A. Diese Einrichtung kann im Wohnbereich Funkstörungen verursachen; in diesem fall kann vom Betreiber verlangt werden, angemessene Maßnahmen durchführen.

Standard Europeo

Attenzione

Questo e' un prodotto di classe A. Se usato in vicinanza di residenze private potrebbe causare interferenze radio che potrebbero richiedere all'utilizzatore opportune misure.

Attention

Ce produit est de classe "A". Dans un environnement domestique, ce produit peut être la cause d'interférences radio. Dans ce cas l'utilisateur peut être amené à prendre les mesures adéquates.

PATENTS

This METROLOGIC product may be covered by one or more of the following U.S. Patents:

U.S. Patent No. 5,260,553; 5,340,971; 5,340,973; 5,424,525; 5,468,951; 5,484,992; 5,525,789; 5,528,024; 5,627,359; 5,661,292; 5,742,043; 5,756,982; 5,777,315; 5,789,730; 5,789,731; 5,825,012; 5,874,721; 5,886,337; 5,925,870; 5,925,871; 5,984,187; 6,029,894; 6,085,981; 6,189,793; 6,209,789; 6,223,987; 6,227,450; 6,347,743; 6,427,917; 6,648,229

4,360,798; 4,369,361; 4,387,297; 4,460,120; 4,496,831; 4,593,186; 4,607,156; 4,673,805; 4,736,095; 4,758,717; 4,816,660; 4,845,350; 4,896,026; 4,923,281; 4,933,538; 4,992,717; 5,015,833; 5,017,765; 5,059,779; 5,117,098; 5,124,539; 5,130,520; 5,132,525; 5,140,144; 5,149,950; 5,180,904; 5,200,599; 5,229,591; 5,247,162; 5,250,790; 5,250,791; 5,250,792; 5,262,628; 5,280,162; 5,280,164; 5,304,788; 5,321,246; 5,324,924; 5,396,053; 5,396,055; 5,408,081; 5,410,139; 5,436,440; 5,449,891; 5,468,949; 5,479,000; 5,532,469; 5,545,889;

No license right or sublicense is granted, either expressly or by implication, estoppel, or otherwise, under any METROLOGIC® or third party intellectual property rights (whether or not such third party rights are licensed to METROLOGIC), including any third party patent listed above, except for an implied license only for the normal intended use of the specific equipment, circuits, and devices represented by or contained in the METROLOGIC products that are physically transferred to the user, and only to the extent of METROLOGIC's license rights and subject to any conditions, covenants and restrictions therein.

Other worldwide patents pending.

INDEX

A

application 1
audible..... 5–9
autodiscriminates 13

B

bar code 4, 5–9, 10, 11, 19
beep 5–9, 13, 14, 19

C

cable..... 1, 4, 13
caution..... 10, 21
CDRH..... 10, 13
communication 1, 4, 5–9, 14–18
compliance 20
contrast 13
current 13
customer service ii, 1, 20

D

DC transformer..... 13
decode capability 13
default 14–18
depth of field..... 12
dimensions 13

E

electrical 13
EMC 13
environmental..... 13

F

function..... 14

G

good read 13
green LED 4, 5–9

H

host 4, 11, 14–18
humidity..... 13

I

indicators 5–9, 13
input voltage..... 13

installation..... 1
interfaces 1

K

keyboard wedge..... 1, 13, 14–18

L

labels 10
LED..... 4, 5–9, 11, 13, 19
light levels 13
light pen emulation..... 1, 13, 14–18
light source 13
limited warranty..... 20
locations..... ii
long range activation..... 1, 11, 14

M

maintenance 10
manual 21
mechanical..... 13
min bar width 13
model number..... 10

N

notices 21, 22

O

operating current..... 13
operating temperature 13
operation 13, 21
operational..... 13
output window 4, 5–9, 10, 12

P

parameter 14–18
parts..... 4
patents 23
PC..... 1, 13, 17
power 5–9, 11, 13
print contrast 13
programming guide..... 1, 9
property..... 23
protocols 14–18

INDEX

R

razzberry tone9, 14
red LED4, 5–9
repair20
rights23
RMA20
roll, pitch, yaw.....13
RS23213, 14–18

S

scan field5–9, 11, 12
scan pattern13
scan speed1, 13
serial number10
serviceii, 20
shock13
short range activation.....1, 11, 14
software19
specifications.....4, 13
stand1, 13
storage13
system interfaces1, 13

T

temperature13
termination13
Test17
test code19
tones9, 13
troubleshooting19

U

USB14–18
USB keyboard emulation19

V

ventilation.....13
visual5–9

W

warning22
warranty20
watts13
weight13
window4, 5–9, 10, 11, 12

NOTES



November 2004
Printed in the USA



00 - 02348C