

# Installation Instructions

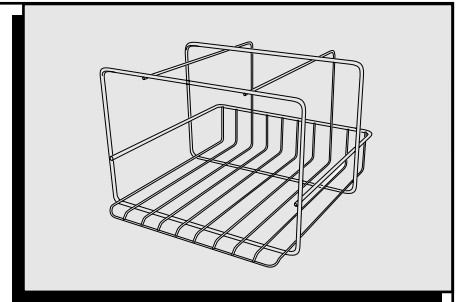

## LAKELAND™ UNDERCABINET STORAGE RACK 8193.140

Thank you for selecting American-Standard...the benchmark of fine quality for over 100 years. To ensure that your installation proceeds smoothly-- please read these instructions carefully before you begin.

### BEFORE YOU BEGIN:

- Carefully unpack your accessory, check the contents, and inspect carefully for damage.
- **Mounting Kit Consists Of:**
  - 4 Clips
  - 2 Long and 2 Short Metric Machine Screws
  - 10 Flat and 4 Anti-shake (star) washers. Fig 4.

### RECOMMENDED TOOLS & MATERIALS:

- Phillips Screwdriver
- Pliers
- Regular Screwdriver (Small)
- Tape Measure
- Masking Tape or Yellow Crayon
- Flash Light

**Note:** The top of the rack is manufactured with a slope. When it is correctly installed under the sink the bottom of the rack will be parallel with the rim of the sink.

**IMPORTANT:** DIMENSION OF FIXTURES ARE NOMINAL AND MAY VARY WITHIN PERMITTED MANUFACTURING TOLERANCES.

- 1**
- Locate the fixing screw holes on the underside of the sink.
  - Make sure the threads are clear and mark around them. Fig 1.

Fig.1



- 2**
- Put two clips on each of the top thick wires.
  - Gently squeeze them closed.
  - The exact location of the clips may vary depending on whether you want to position your storage rack to the left or right. Fig 2 & 3.

Fig.2

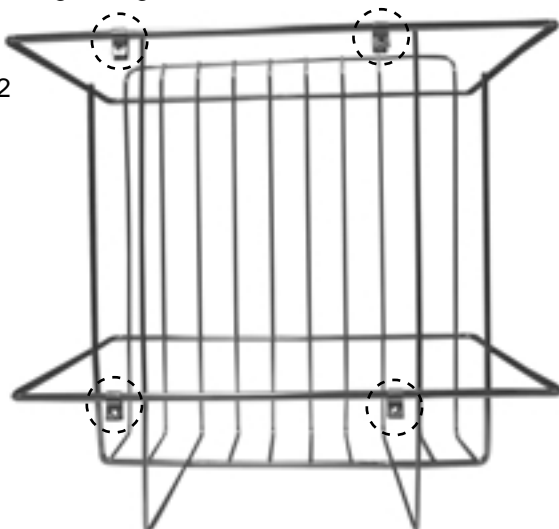
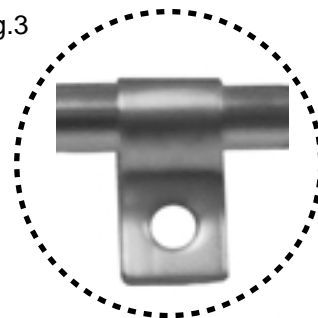
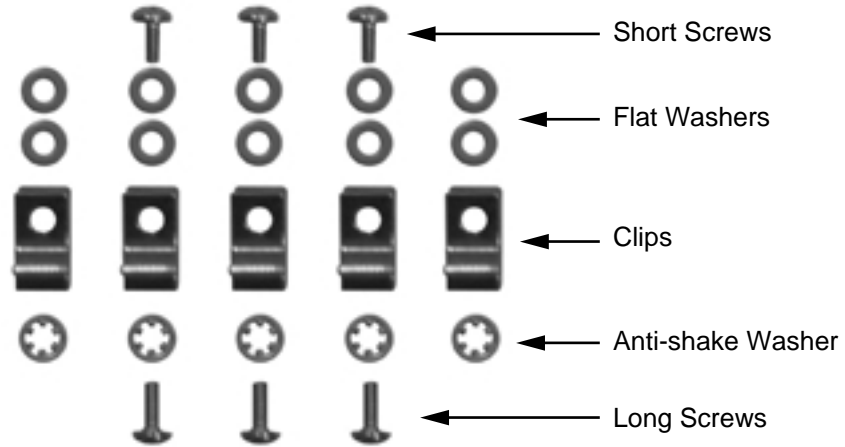

Fig.3



- 3** • Place one anti-shake and then one flat washer on two long and two short screws. (Extra included in pack.)

Fig.4



- 4** • Position the rack under the sink and secure in place with the screws. Fig.5

**Note:** The long screws go to the right hand side (outer edge) and the short screws go to the left hand side (center) when looking from the front. Fig.6

Fig.5



Fig.6

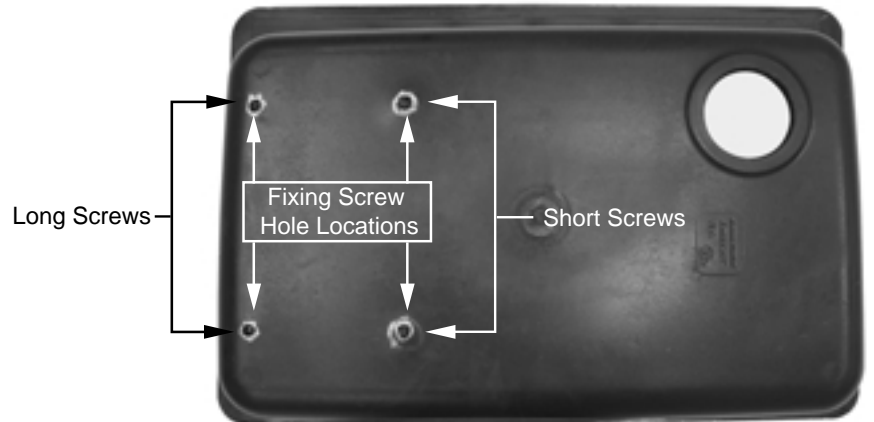

- 5** • Gently tighten the screws. DO NOT OVER TIGHTEN THE SCREWS AS THIS MAY BREAK THE WELD NUT  
• If a clip is not tight on the wire, remove the screw and add more flat washers until the clip grips the wire. Fig.7.

Fig.7

