

Not Recommended for New Installations.

Please contact Technical Support for more information.

Optically Isolated Serial Data Acquisition Module

232OPSDA Module

Documentation Number 232OPSDA1397

This product

Designed and Manufactured

In Ottawa, Illinois

USA

of domestic and imported parts by

B&B Electronics Mfg. Co. Inc.

707 Dayton Road -- P.O. Box 1040 -- Ottawa, IL 61350

PH (815) 433-5100 -- FAX (815) 433-5105

Internet:

<http://www.bb-elec.com>

orders@bb-elec.com

support@bb.elec.com

Copyright © 1997 by B&B Electronics Mfg. Co. All rights reserved.

TABLE OF CONTENTS

CHAPTER 1: INTRODUCTION	1
232OPSDA FEATURES	1
PACKING LIST	2
SOFTWARE INSTALLATION	3
232OPSDA SPECIFICATIONS	3
<i>Analog to Digital Converter</i>	3
<i>Digital Input</i>	4
<i>Digital Output</i>	4
<i>Power Supply</i>	4
<i>Communications</i>	4
CHAPTER 2: CONNECTIONS	5
A/D CONNECTIONS	5
DIGITAL I/O CONNECTIONS.....	7
<i>Digital Input</i>	7
<i>Digital Output</i>	7
SERIAL PORT CONNECTIONS	7
POWER SUPPLY CONNECTIONS	9
CHAPTER 3: COMMANDS	11
SYNTAX	12
READING A/D CHANNELS COMMAND.....	13
READING DIGITAL I/O COMMAND	14
SET DIGITAL OUTPUT COMMAND	14
CHAPTER 4: A/D.....	15
SAMPLING RATE	15
A/D CONVERTER RANGE.....	15
<i>Non-buffered 0 to 5VDC A/D Inputs</i>	15
<i>Buffered 0 to 5V A/D Inputs</i>	15
<i>0 to 10VDC A/D Input</i>	16
<i>4-20mA Current Loop A/D Input</i>	16
CHAPTER 5: SOFTWARE	19
APPLICATION PROGRAM INTERFACE	19
<i>B232OPSDA_ReadAnalog</i>	19
<i>B232OPSDA_ReadDigital</i>	20
<i>B232OPSDA_SetDigitalOutput</i>	21
<i>deinitComPort</i>	21
<i>initComPort</i>	21
LOW-LEVEL COMMUNICATIONS.....	22
<i>Read A/D Command</i>	23
<i>Read Digital I/O Command</i>	24
<i>Set Digital Output State</i>	26

APPENDIX A: DEC TO HEX TO ASCII CONVERSION..... A-27

APPENDIX B: 232OPSDA SCHEMATIC & BOARDB-29

Chapter 1: Introduction

232OPSDA Features

The 232OPSDA is an optically isolated data acquisition module that is connected to your computer's RS-232 serial port. It provides 2500V of optical isolation protection between the I/O and RS-232 side of the module. The 232OPSDA offers six channels of 12-bit A/D, one digital input, and one digital output. The six A/D input channels can be used for a number of applications. One A/D channel can read a 4-20mA analog current, two buffered channels read voltages between 0 and 5V, two non-buffered channels read voltages between 0 and 5V, and one channel can read voltages between 0 and 10V.

The 232OPSDA connects to your computer's RS-232 serial port through a DB-25S (female) connector. The module automatically detects baud rates from 1,200 to 9,600. A data format of 8 data bits, 1 stop bit, and no parity is used.

The RS-232 side of the 232OPSDA is port powered. Power is drawn from RTS and DTR regardless of whether they are asserted HIGH or LOW. In addition, an isolated external power supply is required to power the I/O side of the module. Both port-powering and the external power supply are required. The 232OPSDA requires a power supply that produces 9-16VDC @ 10mA (not including power consumption of external devices).



Figure 1.1: 232OPSDA Module

Terminal Blocks

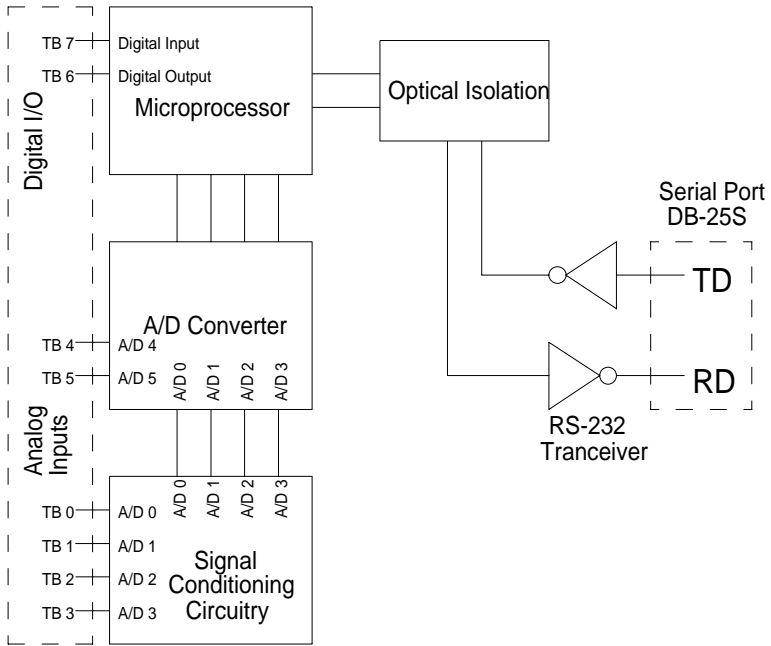

Figure 1.2: General Block Diagram

Packing List

Examine the shipping carton and the contents for physical damage. The following items should be in the shipping carton:

1. 232OPSDA module
2. One 232OPSDA 3.5" disk
3. This instruction manual

If any of these items are missing or damaged, contact B&B Electronics immediately.

Software Installation

The 232OPSDA comes with several a demonstration program. To install these programs on your hard drive:

1. Place the disk in drive A.
2. Type **A:** and press the **<ENTER>** key.
3. Type **INSTALL** and press the **<ENTER>** key.
4. Follow the instructions given by the program.

The file, READ.ME, contains corrections and additions to the printed user's manual. The file, FILES.LST, contains a list and description of the files installed on the hard drive. The file, HISTORY.LST, contains a historic description of the 232OPSDA.

232OPSDA Specifications

Analog to Digital Converter

Resolution:	12 bit
Channels:	6
A/D Connections:	Terminal Blocks
4-20mA channel:	1
Input Resistance:	10 Ω
Input Offset voltage:	1500 μ V
Input Offset Voltage Drift:	0.5 μ V/ $^{\circ}$ C
Signal Conditioning Error:	\pm 3% of output
0 to 5V Buffered Input Channels:	2
Input Resistance:	1T Ω
Input Offset voltage:	1500 μ V
Input Offset Voltage Drift:	0.5 μ V/ $^{\circ}$ C
Signal Conditioning Error:	\pm 1% of output
0 to 10V Input Channel:	1
Input Resistance:	200K Ω
Input Offset voltage:	1500 μ V
Input Offset Voltage Drift:	0.5 μ V/ $^{\circ}$ C
Signal Conditioning Error:	\pm 1% of output
0 to 5V Non-buffered Input Channels:	2
Input Offset voltage:	1500 μ V
Input Offset Voltage Drift:	0.5 μ V/ $^{\circ}$ C
Total Unadjusted Error:	\pm 1.75LSB

Non-buffered A/D input channels must be driven from a source impedance less than 1K Ω .

Digital Input

Channels: 1
Voltage Range: -30VDC to +30VDC
Low Voltage: -30VDC to 1.0VDC
High Voltage: 2.0VDC to 30VDC
Leakage Current: 1 μ A maximum

Digital Output

Channels: 1
Low Voltage: 0.6VDC @ 8.7mA
High Voltage: 4.3VDC @ -5.4mA

Power Supply

Input Voltage: 9-16VDC @ 10mA (Does not include the power consumption of external devices.)
Connections: Terminal Blocks

Communications

Standard: RS-232 (unit is DCE)
Baud Rate: 1,200 to 9,600 (automatic detection)
Format: 8 data bits, 1 stop bit, no parity
Isolation Protection: 2500V (Power supply not considered)
Port Power: RTS and DTR (either state)
Connections: DB-25S (female)

Chapter 2: Connections

This chapter will cover the connections required for the 232OPSDA. Four sets of connections are required: A/D converter, digital I/O, serial port, and power supply connections. Do not make any connections until you have read this chapter. If you do not use a particular type of connection, it is still important to read each section. Table 2.1 shows the terminal block assignments.

Table 2.1: Terminal Block Assignments

Terminal Block	Function	Description
TB 0	A/D 0	4-20mA Current Loop Input Channel*
TB 1	A/D 1	Buffered 0 to 5V A/D Channel**
TB 2	A/D 2	Buffered 0 to 5V A/D Channel
TB 3	A/D 3	0 to 10V A/D Channel
TB 4	A/D 4	Non-buffered 0 to 5V A/D Channel
TB 5	A/D 5	Non-buffered 0 to 5V A/D Channel
TB 6	Digital out	Digital Output
TB 7	Digital in	Digital Input
GND	GND	Ground
+12VDC	+12VDC	Power Supply Connection

* The current loop input uses a non-inverting amplifier that has a gain of 23.064. Space for through-hole resistors is provided to change the gain. By decreasing the gain, currents up to 100mA can be read with A/D 0.

** This A/D input uses a voltage follower circuit. Spaces for through-hole resistors are provided to convert the voltage follower into a non-inverting amplifier with gain > 1.

A/D Connections

The A/D connections are made on the I/O port which consists of ten terminal blocks. Terminal Blocks 0-5 are A/D channels 0-5. These six A/D channels are referenced to GND (terminal block 8). The 4-20mA Current Loop A/D channel requires connections different from the other five channels, so two different diagrams are shown for required A/D connections. Figure 2.1 shows the connections required for the 4-20mA Current Loop channel (A/D 0), and Figure 2.2 shows the connections required for A/D channels 1-5.

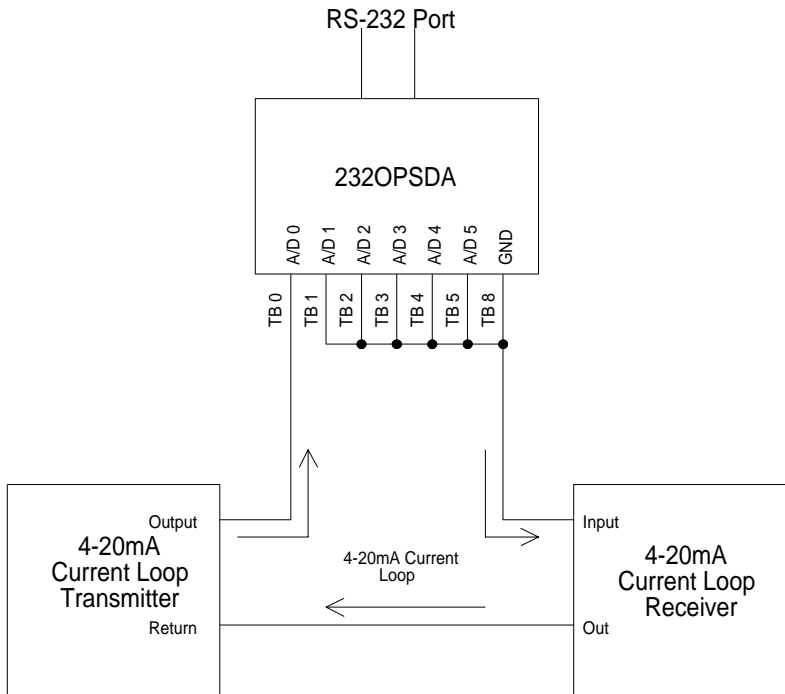

Figure 2.1: Current Loop Channel Connections (A/D 0)

NOTE: When using the 4-20mA Current Loop Input with the setup shown in Figure 2.1, A/D 1-5 cannot be used and should be connected to the terminal block labeled GND.

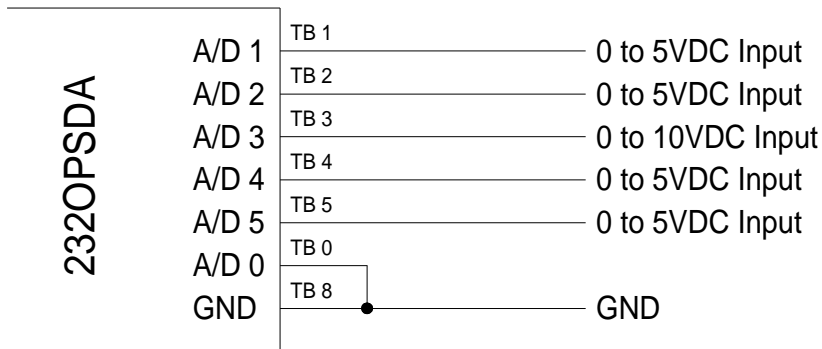

Figure 2.2: Required Connections for A/D 1- A/D 5

Digital I/O Connections

The digital I/O connections are made on the I/O port, which consists of terminal blocks. Table 2.1 shows the terminal block assignments.

Digital Input

Terminal block 7 is the digital input line. This input is CMOS/TTL compatible and can handle voltage from -30VDC to 30VDC. If a digital input is from -30VDC to 1.0VDC, the state will be read as a "0" (LOW). If a digital input is from 2.0VDC to 30VDC, the state will be read as a "1" (HIGH). If the digital input is not used, it should be connected to GND. Figure 2.3 show the connections required for the digital input.

Digital Output

Terminal Block 6 is the digital output line. This line is CMOS/TTL compatible. When the digital output is set to "0" (LOW), the output voltage will be between 0 and 0.6VDC. When the digital output is set to "1" (HIGH), the output voltage will be between 4.3VDC to 5.0VDC. Figure 2.3 shows the connections required for the digital output.

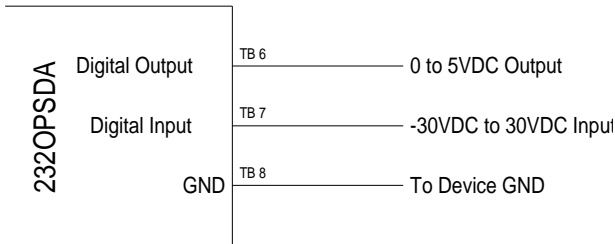

Figure 2.3: Digital I/O Required Connections

Serial Port Connections

In order to communicate with the 232OPSDA module it must be connected to an RS-232 serial port. The unit automatically detects baud rates from 1,200 to 9,600. A data format of 8 data bits, 1 stop bit and no parity is used. The 232OPSDA is configured as a DCE device (See Table 2.2). If your communications equipment is configured as a DTE device, such as a standard IBM PC serial port, the 232OPSDA should be connected using a "straight through" DB-25 cable or a standard DB-9 to DB-25 cable adapter as shown in Table 2.3. If your communications equipment is configured as a DCE device, such as a modem, the 232OPSDA should be connected using a "null modem" cable (See Table 2.4).

Table 2.2 - RS-232 Connector Pinout

DB25S Pin #	Signal	232OPSD A Function	Notes
2	Transmit Data (TD)	Input	Connection is required.
3	Receive Data (RD)	Output	Connection is required.
4	Request to Send (RTS)	Input	Used for power.
5	Clear to Send (CTS)		Internally connected to RTS (pin 4).
6	Data Set Ready (DSR)		Internally connected to DTR (pin 20).
7	Signal Ground (SG)		Connection is required.
8	Data Carrier Detect (DCD)		Internally connected to to DTR (pin 20).
12	Signal Ground (SG)		
20	Data Terminal Ready (DTR)	Input	Used for power.
25	Optional Power Supply Connection		Connect Power Supply to this pin if RTS and DTR are not available

Table 2.3 - 232OPSDA To DTE Connections

232SPDA Pin #	Signal	DTE DB-25 Connection	DTE DB-9 Connection
2	Transmit Data (TD)	2	3
3	Receive Data (RD)	3	2
4	Request to Send (RTS)	4	7
5	Clear to Send (CTS)	5	8
6	Data Set Ready (DSR)	6	6
7	Signal Ground (SG)	7	5
8	Data Carrier Detect (DCD)	8	1
20	Data Terminal Ready (DTR)	20	4

Table 2.4 - 232OPSDA To DCE Connections

232OPSDA Pin #	Signal	DCE DB-25 Connection	DCE DB-9 Connection
2	Transmit Data (TD)	3	2
3	Receive Data (RD)	2	3
4	Request to Send (RTS)	5	8
5	Clear to Send (CTS)	4	7
6	Data Set Ready (DSR)	20	4
7	Signal Ground (SG)	7	5
8	Data Carrier Detect (DCD)	N/C	N/C
20	Data Terminal Ready (DTR)	6	6

Power Supply Connections

The 232OPSDA requires an isolated external power supply that is able to produce 9-16VDC @10mA in addition to the port power. The positive(+) lead of the power supply is connected to the terminal block labeled +12VDC and the negative(-) lead is connected to the terminal block labeled GND. The external power supply powers the I/O side of the module. The RS-232 side of the module is port powered using RTS and DTR. These lines may be either LOW or HIGH to provide power to the module. The two sources of power are required for optical isolation.

Chapter 3: Commands

Only three commands are required to operate the 232OPSDA: the read A/D command, read digital I/O command, and the set digital output command. The command string consists of four bytes. The read A/D and digital I/O commands require an additional data byte. See Table 3.1.

Table 3.1: 232OPSDA Commands

Function	Command	Response
Read A/D Channels	!0RA{#}	{ch#msb}{ch#lsb}{ch(#-1)msb}... {ch0msb}{ch0lsb}
Read Digital I/O	!0RD	{I/O states}
Set Digital Output	!0SO{#}	no response

NOTE: Each {...} represents one byte.

In addition to the commands mentioned above, an extended set of commands are provided that support bit-error identification. These commands use the “#” character in place of the “!” character, and the compliment of the data byte must be sent after the data byte. The extended commands are shown in table 3.2.

Table 3.1: 232OPSDA Commands

Function	Command	Response
Read A/D Channels	#0RA{#}~{#}	{ch#msb}~{ch#msb}{ch#lsb}{ch#lsb} {ch(#-1)msb}~{ch(#-1)msb}....{ch0msb} ~{ch0msb}{ch0lsb}~{ch0lsb}
Read Digital I/O	#0RD	{I/O states}~{I/O states}
Set Digital Output	#0SO{#}~{#}	no response

NOTE: ~{...} represents the complement of one byte.

Before going into the specifics of each command, it is important to understand that a byte has a value from 0 to 255 and can be represented in decimal (0 to 255), hexadecimal (00 to FF), or by an ASCII character. The commands in Table 3.1 are shown in ASCII, for example: “!0RD”. The decimal and hexadecimal equivalents of some ASCII characters are shown in Table 3.2. Notice that the ASCII representation of the character “0” does not have a value of 0. Refer to Appendix A for more ASCII, decimal, and hexadecimal equivalents.

Table 3.3 - Read A/D Response

# of Channels Specified			Response	
decimal	Hex	ASCII	Channels Returned (order of response)	Bytes Returned
0	0	NUL	Channel 0	2
1	1	SOH	Channels 1,0	4
2	2	STX	Channels 2,1,0	6
3	3	ETX	Channels 3,2,...,0	8
4	4	EOT	Channels 4,3,...,0	10
5	5	ENQ	Channels 5,4,...,0	12

NOTE: There are three test channels that can be read: Ref+, Ref-, and Ref+/2. Specify 13 (0Dh) to read Ref+, 12 (0Ch) to read Ref-, and 11 (0Bh) to read Ref+/2.

Reading Digital I/O Command

The Read Digital I/O command returns a byte which represents the state of the digital input and digital output. Bit 0 corresponds to the state of the digital output, and bit 3 corresponds to the state of the digital input. If a bit is a 0 then the digital state of that digital I/O is LOW. If a bit is a 1 then the digital state of the I/O is HIGH. NOTE: Bits 1-2 and 4-7 of the data byte are ignored.

Command Syntax

```
!ORD
```

Unit Response

```
{states}
```

Where **{states}** is a byte in which bits 0 corresponds to the current state of the digital output and bit 3 corresponds to the current state of the digital input.

Set Digital Output Command

The Set Digital Output command is used to set the state of the digital output line. This command requires a data byte. The data byte is used to specify the output state. Bits 0 corresponds to the state of the digital output. If bit 0 is a 0 then the output will be set LOW. If bit 0 is a 1 then the output will be set HIGH. NOTE: This command ignores bits 1-7 of the data byte.

Command Syntax

```
!OSO{states}
```

Where **{states}** is a byte in which bit 0 corresponds to the output state of the digital outputs.

Unit Response

```
no response
```

Chapter 4: A/D

This chapter will deal with the various A/D channels and manipulating the data obtained from them.

Sampling Rate

The A/D converter has a conversion time around 10 microseconds, however, the actual sampling rate is limited by the serial communications. The actual sampling rate for a single channel is around 120 samples per second (9600 baud). This rate drops to around 41 samples per second when sampling all of the channels. When reading an A/D input, the 232OPSDA takes four readings and returns the average (0.5 and greater are rounded up) of these readings. This averaging helps filter out noise.

A/D Converter Range

The actual A/D converter chip in the 232OPSDA is a 12 bit A/D converter that can read analog voltages between 0 and 5VDC. However, the 232OPSDA contains signal conditioning circuitry that allows you to measure voltages from 0 to 10VDC (Gain = 0.5) as well as other ranges. In the following sections, each channel configuration will be covered.

Non-buffered 0 to 5VDC A/D Inputs

The 232OPSDA has two non-buffered 0 to 5V inputs. They are A/D 4 on Terminal Block 4 and A/D 5 on Terminal Block 5. The voltage applied to the Terminal Blocks is the voltage that is read by the A/D converter chip. The driving source impedance should be less than 1K Ω for these two channels.

Buffered 0 to 5V A/D Inputs

The 232OPSDA has two buffered 0 to 5V inputs. They are A/D 1 on Terminal Block 1 and A/D 2 on Terminal Block 2. An operational amplifier is setup as a voltage follower to buffer the A/D converter from the source of the voltage. The input resistance of each of these channels is 1T Ω . This allows you to have a large source impedance.

Both A/D 1 and A/D 2 are set up as voltage followers with a gain of 1 when they leave the factory. However, the voltage follower for A/D 1 (TB 1) has spaces for optional through hole resistors. This allows you to reconfigure A/D 1 into a non-inverting amplifier configuration. A non-inverting amplifier can have a gain greater than 1. See the circuit schematic in Figure B.1 and board layout in Figure B.2 in Appendix B. To change the voltage follower into a non-

inverting amplifier, remove R15 and calculate values for R13 and R14 using the equation below.

$$Gain = \frac{V_0}{V_{in}} = 1 + \frac{R13}{R14}$$

NOTE: V_0 is the voltage read by the A/D converter chip, and V_{in} is the voltage at TB1. R13 and R14 should be chosen so that V_0 does not exceed 5.00VDC.

0 to 10VDC A/D Input

The 232OPSDA contains one A/D input than is capable of handling voltages between 0VDC and 10VDC. This channel is A/D 3 and is located on Terminal Block 3. The gain of the signal conditioning circuitry for this channel is 0.5. If 10VDC is applied to Terminal Block 3, the A/D Converter chip will read 5.00V. The input resistance of this channel is 200K Ω , so the driving source impedance should be less than 1K Ω to minimize voltage division error.

4-20mA Current Loop A/D Input

The 232OPSDA has one A/D channel capable of monitoring the loop current in a 4-20mA analog current loop. See figure B.1 in Appendix B for a circuit schematic. A 10 Ω resistor is connected between TB 0 and GND inside the 232OPSDA. The voltage drop across this resistor is proportional to the current in the current loop. With the original configuration, the following equation can be used to convert the voltage read by the A/D converter chip to the actual current in the loop. The value 23.064 is the gain of the signal conditioning circuitry

$$LoopCurrent(mA) = \frac{1000 \times AD_0}{23.064 \times 10\Omega}$$

NOTE: AD_0 is the voltage read by the A/D converter chip. This voltage is between 0 and 5.00VDC.

The signal conditioning circuit for this A/D input channel has been designed to be easily modified. In the original configuration, R5 and R6 are left OPEN (they are not present). These two spaces are provided if you need a different gain. Reducing the gain of this non-inverting amplifier allows you to measure currents up to 100mA, and increasing the gain allows you to read much smaller currents with greater accuracy. See the circuit schematic in Figure B.1 and board layout in Figure B.2 in Appendix B.

To change the gain of this non-inverting amplifier, remove R8 and R9, and calculate values for R4 and R5 using the equation below.

$$Gain = \frac{V_0}{10 \times LoopCurrent} = 1 + \frac{R5}{R4}$$

NOTE: V_0 is the voltage read by the A/D converter and (10 x loop current) is the voltage drop across the 10Ω resistor. R4 and R5 should be chosen so that V_0 does not exceed 5.00VDC.

NOTE: Decreasing the gain allows you to measure larger currents, but the maximum current that can be read is 100mA. The 100mA limit is due to the power rating of the 10Ω resistor (0.125W).

NOTE: When using the 4-20mA current loop input, A/D 1 - A/D 5 should be connected to the terminal block labeled GND.

Chapter 5: Software

Application Program Interface

The application program interface (API) is a set of routines that makes it easy to communicate with the 232OPSDA module from a 16-bit DOS application. Example programs using the API are written in Borland C++, Borland Pascal and Microsoft® QuickBASIC v4.5. The batch file, MAKEIT.BAT, in the directory for each language shows how to compile and link the demo program with the API routines.

B232OPSDA_ReadAnalog

Purpose: This function reads the A/D input channels.

Syntax: C: BOOL B232OPSDA_ReadAnalog (WORD *hComDev*,
 BYTE *modAddr*, WORD *channels*, WORD* *data*);

Pascal: function B232OPSDA_ReadAnalog (*hComDev* :
 word; *modAddr* : byte; *channels* : word;
 data : Pword);

BASIC: FUNCTION B232OPSDAReadAnalog (BYVAL
 hComDev AS INTEGER, BYVAL *modAddr* AS
 INTEGER, BYVAL *channels* AS INTEGER, BYVAL
 wdataseg AS INTEGER, BYVAL *wdataoff* AS
 INTEGER)

Remarks: *hComDev* is the handle to a serial port where the module is connected. This is the value returned by *initComPort*. *modAddr* is the module address, which is always 30H (48 decimal) for the 232OPSDA module. *channels* is a bit mask for the A/D input channels that should be read. See the table below for the meaning of each bit.

Bit	Channel	Value (hex)	Value (decimal)
Bit 7	(nothing)	80H	128
Bit 6	(nothing)	40H	64
Bit 5	A/D Channel 5	20H	32
Bit 4	A/D Channel 4	10H	16
Bit 3	A/D Channel 3	08H	8
Bit 2	A/D Channel 2	04H	4
Bit 1	A/D Channel 1	02H	2
Bit 0	A/D Channel 0	01H	1

data is that address of an array of 16-bit values where the results of the A/D conversion will be stored.

For QuickBASIC users: *wdataseg* and *wdataoff* are the

segment and offset addresses of the integer array where the results of the A/D conversion will be stored.

Returns: FALSE (zero) if the function fails, otherwise it returns TRUE (non-zero).

B232OPSDA_ReadDigital

Purpose: This function reads the states of all the digital I/O lines.

Syntax: C: `BOOL B232OPSDA_ReadDigital (WORD hComDev, BYTE modAddr, WORD* data);`

Pascal: `function B232OPSDA_ReadDigital (hComDev : word; modAddr : byte; data : Pword);`

BASIC: `FUNCTION B232OPSDAReadDigital (BYVAL hComDev AS INTEGER, BYVAL modAddr AS INTEGER, BYVAL wdataseg AS INTEGER, BYVAL wdataoff AS INTEGER)`

Remarks: *hComDev* is the handle to a serial port where the module is connected. This is the value returned by *initComPort*. *modAddr* is the module address. This is always 30H (48 decimal) for the 232OPSDA module. *data* is the address of the 16-bit value where the digital I/O values will be stored. If bit 0 (01H; 1 decimal) of *data* is set, then digital input 0 is on, otherwise it is off. If bit 4 (10H; 16 decimal) of *data* is set, then digital output 1 is on, otherwise it is off.

For QuickBASIC users: *wdataseg* and *wdataoff* are the segment and offset addresses of the integer the digital I/O values will be stored.

Returns: FALSE (zero) if the function fails, otherwise it returns TRUE (non-zero).

B232OPSDA_SetDigitalOutput

Purpose: This function sets the states of the digital output lines.

Syntax:

C:

```
BOOL B232OPSDA_SetDigitalOutput (WORD
hComDev, BYTE modAddr, WORD lines, WORD
states);
```

Pascal:

```
function B232OPSDA_ReadDigitalOutput
(hComDev : word; modAddr : byte; lines :
word; states : word);
```

BASIC:

```
FUNCTION B232OPSDAreadDigitalOutput
(BYVAL hComDev AS INTEGER, BYVAL modAddr
AS INTEGER, BYVAL lines AS INTEGER, BYVAL
states AS INTEGER)
```

Remarks: *hComDev* is the handle to a serial port where the module is connected. This is the value returned by *initComPort*. *modAddr* is the module address. This is always 30H (48 decimal) for 232OPSDA module. *lines* is a bit mask of the digital outputs to change. This will always be 01H (1 decimal) of the 232OPSDA, because it only has one digital output line. *states* is the new state of the digital outputs specified in *lines*. This can be either zero for OFF or non-zero for ON.

Returns: FALSE (zero) if the function fails, otherwise it returns TRUE (non-zero).

deinitComPort

Purpose: Removes the serial communications port driver.

Syntax:

C:

```
void deinitComPort (WORD hComDev);
```

Pascal:

```
procedure deinitComPort (hComDev : word);
```

BASIC:

```
sub deinitComPort (BYVAL hComDev AS
INTEGER);
```

Remarks: This function must be called after a serial communications port is installed with *initComPort* to remove the interrupt service routine that it installs.

Returns: Nothing.

See Also: *initComPort*

initComPort

Purpose: Installs a serial communications port driver.

Syntax:

```

C:      WORD initComPort (WORD portAddr, BYTE irq,
                        LONG baudRate);

Pascal: function initComPort (portAddr : word; irq
                        : byte; baudRate : longint) as integer;

BASIC:  FUNCTION initComPort% (BYVAL portAddr AS
                        INTEGER, BYVAL irq AS INTEGER, BYVAL
                        baudRate AS INTEGER)

```

Remarks: *portAddr* is the address of the serial port. *irq* is the interrupt request number that the serial port uses. *baudRate* is the speed at which the API talks to the 232OPSDA module. Common port addresses and irq numbers are:

Port	Address	IRQ
COM1	3F8H	4
COM2	2F8H	3
COM3	3E8H	4
COM4	2E8H	3

`deinitComPort` must be called to remove the interrupt service routine installed by `initComPort`. The results are unpredictable if you terminate your application without calling `deinitComPort`.

Returns: A handle that uniquely identifies the installed serial port.

See Also: `deinitComPort`

Low-Level Communications

This section covers the low-level commands that are sent to the module through a serial communications port and the responses from the module. Detailed discussion of the command and responses are covered in Chapter 3. The examples shown here are in Microsoft® QuickBASIC. If you are programming in another language, this information can be used as a guideline for programming for the 232OPSDA module. To open and close a serial communications port in QuickBASIC use:

```

\ Open the serial port.
\
OPEN "COM1:9600,N,8,1,cd,ds" FOR RANDOM AS #1
PAUSE (.5)

\ Close the serial port when finished.
\
CLOSE #1

```

Read A/D Command

The read A/D channels command returns two bytes of data for each channel read. The two bytes represent the most significant byte (MSB) and least significant byte (LSB) of the reading. The MSB is received first, followed by the LSB. This command requires a data byte. The data byte is used to specify the number of the highest channel to be read. All channels less than this channel will be read as well.

Step 1 - Constructing the command string:

```
Command$ = "!0RA" + CHR$(channel)
```

The value of channel is equal to the highest channel to be read.

Step 2 - Transmitting the command string:

```
Print #1, Command$;
```

Step 3 - Receiving the data:

```
MSB$ = INPUT$(1, #1)
LSB$ = INPUT$(1, #1)
```

Step 4 - Manipulating the data:

```
reading = (ASC(MSB$) * 256) + ASC(LSB$)
```

The value of *reading* is the result of the A/D conversion.

Step 5 - Repeat Step 3 and 4 until each channel has been completed.

Step 6 - The various A/D channels have signal conditioning, so mathematical manipulation of the voltage read will have to be performed. See Chapter 4 for the equations.

Example 5.1 - Read A/D channels 1 and 0

```
gain0 = 23.064
gain1 = 1!

channel = 1
Command$ = "!0RA" + CHR$(channel)
Print #1, Command$;

` Get the value of channel 1
MSB$ = INPUT$(1, #1)
LSB$ = INPUT(1, #1)
ad1 = (ASC(MSB$) * 256) + ACS(LSB$)
reading1 = 5! * ad1 / (gain1 * 4095!)

` Get the value of channel 0
MSB$ = INPUT$(1, #1)
LSB$ = INPUT$(1, #1)
ad0 = (ASC(MSB$) * 256) + ACS(LSB$)
reading0 = (((ad0 * 1000!) / 4095!) * 5!) / (10!
*
    gain0)
```

The value of *reading1* is the result of the A/D conversion on channel 1. The value of *reading0* is the result of the A/D conversion on channel 0.

Read Digital I/O Command

The Read Digital I/O command returns a byte which represents the states of the digital input and digital output. Bit 0 corresponds to the state of digital output. Bit 3 corresponds to the state of digital input. If a bit is a 0 then the digital state of that digital I/O is LOW. If a bit is a 1 then the digital state of the I/O is HIGH.

Step 1 - Constructing the command string:

```
Command$ = "!0RD"
```

Step 2 - Transmitting the command string:

```
Print #1, Command$
```

Step 3 - Receiving the data:

```
Reply$ = INPUT$ (1, #1)
```

Step 4 - Manipulating the data:

```
states = ASC(Reply$)
```

Step 5 - Determining an I/O's status

```
status = states AND mask
```

By "ANDing" the value of *states* with the appropriate *mask* of an I/O line, the *status* of can be determined. If *status* is equal to zero then the I/O line is LOW. If *status* is not equal to zero then the I/O line is HIGH. Table 5.1 shows the *mask* values for each I/O.

Table 5.1 - Digital I/O Mask Values

I/O Line	Mask Values	
	Hexadecimal	Decimal
Digital Output #0	1H	1
Digital Input #0	8H	8

Step 6 - Repeat Step 5 until the status of each I/O has been determined.

Example 5.2 - Determining the status of Digital Input #0 of the module.

```
mask = &H8
Command$ = "!0RD"
Print #1, Command$

Reply$ = INPUT$ (1, #1)
states = ASC (Reply$)
status = states AND mask
```

If *status* is equal to zero than Digital Input #0 is LOW. If *status* is not equal to zero than Digital Input #0 is HIGH.

Set Digital Output State

The Set Digital Output command is used to set the state of the digital output line. This command requires a data byte. The data byte is used to specify the output state. Bit 0 corresponds to the state of digital output. If a bit is a 0 then the output will be set LOW. If a bit is a 1 then the output will be set HIGH. Note: This command ignores Bits 1-7 of the data byte.

Step 1a - Constructing the command string:

```
` Set Output HIGH
states = states OR mask
```

By “ORing” the current *states* with the appropriate *mask* of the digital output (given in Table 5.1), the output’s data bit will be set to a “1” (which will be set HIGH).

Step 1b - Set Output LOW

```
states = states AND (NOT(mask))
```

By “ANDing” the current *states* with the complement of the appropriate *mask* of a digital output (given in Table 5.1), the output’s data bit will be set to a “0” (which will be set LOW).

Step 1c - Construct the string

```
Command$ = "!0SO" + CHR$(states)
```

Step 2 - Transmitting the command string:

```
Print #1, Command$
```

Example 5.3 - Set Digital Output #0 HIGH.

```
` Set bit 0 to make Digital Output #0 HIGH
states = states OR 1
Command$ = "!0SO" + CHR$(states)
Print #1, Command$
```

Digital Output #0 will be set HIGH. Note that the variable *states* is assumed to be the value from Example 5.2.

Appendix A: Decimal to Hex to ASCII Conversion

DECIMAL to HEX to ASCII CONVERSION TABLE												
DEC	HEX	ASCII	KEY	DEC	HEX	ASCII	DEC	HEX	ASCII	DEC	HEX	ASCII
0	0	NUL	ctrl @	32	20	SP	64	40	@	96	60	`
1	1	SOH	ctrl A	33	21	!	65	41	A	97	61	a
2	2	STX	ctrl B	34	22	"	66	42	B	98	62	b
3	3	ETX	ctrl C	35	23	#	67	43	C	99	63	c
4	4	EOT	ctrl D	36	24	\$	68	44	D	100	64	d
5	5	ENQ	ctrl E	37	25	%	69	45	E	101	65	e
6	6	ACK	ctrl F	38	26	&	70	46	F	102	66	f
7	7	BEL	ctrl G	39	27	'	71	47	G	103	67	g
8	8	BS	ctrl H	40	28	(72	48	H	104	68	h
9	9	HT	ctrl I	41	29)	73	49	I	105	69	i
10	A	LF	ctrl J	42	2A	*	74	4A	J	106	6A	j
11	B	VT	ctrl K	43	2B	+	75	4B	K	107	6B	k
12	C	FF	ctrl L	44	2C	,	76	4C	L	108	6C	l
13	D	CR	ctrl M	45	2D	-	77	4D	M	109	6D	m
14	E	SO	ctrl N	46	2E	.	78	4E	N	110	6E	n
15	F	SI	ctrl O	47	2F	/	79	4F	O	111	6F	o
16	10	DLE	ctrl P	48	30	0	80	50	P	112	70	p
17	11	DC1	ctrl Q	49	31	1	81	51	Q	113	71	q
18	12	DC2	ctrl R	50	32	2	82	52	R	114	72	r
19	13	DC3	ctrl S	51	33	3	83	53	S	115	73	s
20	14	DC4	ctrl T	52	34	4	84	54	T	116	74	t
21	15	NAK	ctrl U	53	35	5	85	55	U	117	75	u
22	16	SYN	ctrl V	54	36	6	86	56	V	118	76	v
23	17	ETB	ctrl W	55	37	7	87	57	W	119	77	w
24	18	CAN	ctrl X	56	38	8	88	58	X	120	78	x
25	19	EM	ctrl Y	57	39	9	89	59	Y	121	79	y
26	1A	SUB	ctrl Z	58	3A	:	90	5A	Z	122	7A	z
27	1B	ESC	ctrl [59	3B	;	91	5B	[123	7B	{
28	1C	FS	ctrl \	60	3C	<	92	5C	\	124	7C	
29	1D	GS	ctrl]	61	3D	=	93	5D]	125	7D	}
30	1E	RS	ctrl ^	62	3E	>	94	5E	^	126	7E	~
31	1F	US	ctrl _	63	3F	?	95	5F	_	127	7F	DEL