

# Model W1789

## 1/2" Impact Wrench

### Instruction Sheet



Phone #: (360) 734-3482 • Online Tech Support: tech-support@shopfox.biz • Web: www.shopfox.biz

<b>⚠ WARNING</b>	
	<b>EYE INJURY HAZARD!</b> Always wear safety glasses during use to prevent serious personal injury!
	<b>INJURY HAZARD!</b> Always disconnect tool from air to prevent unexpected operation during service!
	<b>INJURY HAZARD!</b> Never exceed 120 PSI!



Figure 1. Model W1789.

### Specifications

Square Drive Size.....	1/2"
Maximum Torque.....	230 ft/lbs.
No Load Speed.....	7,000 RPM
Air Inlet.....	1/4" NPT
Required PSI.....	90 PSI
Average Air Consumption.....	4 CFM
Weight.....	6 lbs.

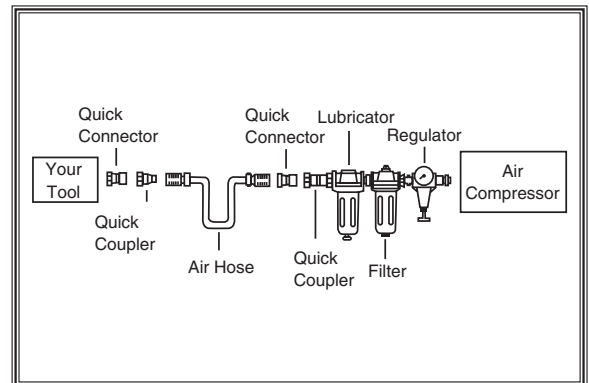

Figure 2. Installing your tool.

### Inventory

- A. Air Impact Wrench .....1
- B. 1/4" NPT Quick Connect Fitting (male) .....1

### Operation

To improve tool lifespan, use a filter/lubricator/regulator as shown in Figure 2. Otherwise, lubricate daily with a couple drops of pneumatic tool oil directly into the air fitting as shown in Figure 3.

**CAUTION: Shattering hazard! Standard sockets may break apart if used on this tool. Use sockets rated for impact wrench use only.**

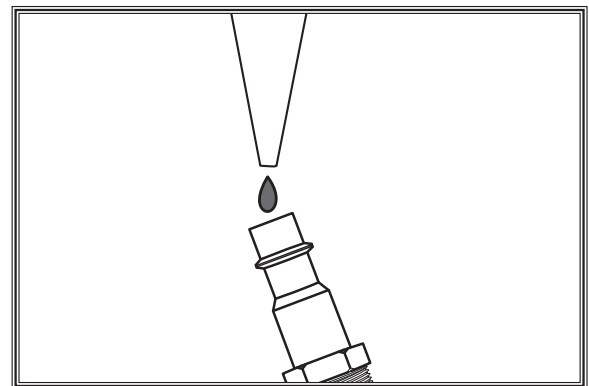

Figure 3. Lubricating directly into air fitting.

**COPYRIGHT © JUNE, 2007 BY WOODSTOCK INTERNATIONAL, INC.**

**WARNING: NO PORTION OF THIS MANUAL MAY BE REPRODUCED IN ANY SHAPE OR FORM WITHOUT**

#9578JM

**THE WRITTEN APPROVAL OF WOODSTOCK INTERNATIONAL, INC.**

**Printed in China**

# W1789 Parts

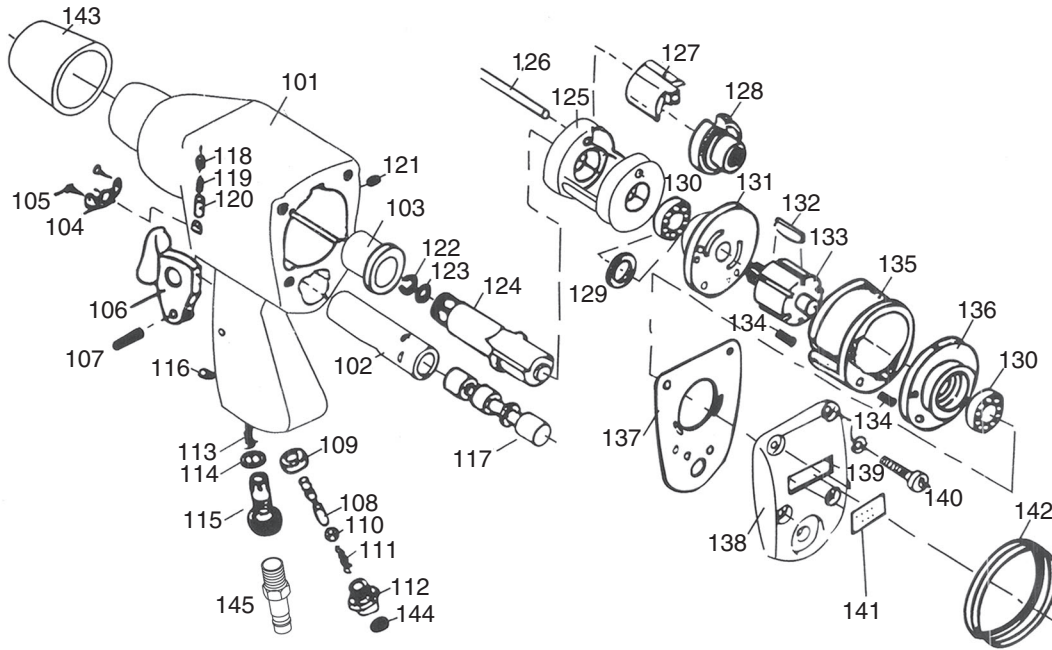

REF	PART #	DESCRIPTION
101	X1789101	HOUSING
102	X1789102	VALVE SLEEVE
103	X1789103	ANVIL BUSHING
104	X1789104	EXHAUST DEFLECTOR
105	X1789105	TAPPING SCREW
106	X1789106	TRIGGER
107	X1789107	SPRING PIN
108	X1789108	VALVE STEM
109	X1789109	BUSHING
110	X1789110	STEEL BALL
111	X1789111	COMPRESSION SPRING
112	X1789112	HOSE ADAPTER
113	X1789113	COMPRESSION SPRING
114	X1789114	O-RING
115	X1789115	AIR REGULATOR
116	X1789116	SET SCREW
117	X1789117	REVERSE VALVE
118	X1789118	PIN
119	X1789119	SPRING
120	X1789120	SET SCREW
121	X1789121	SET SCREW
122	X1789122	ANVIL COLLAR
123	X1789123	O-RING

REF	PART #	DESCRIPTION
124	X1789124	ANVIL
125	X1789125	HAMMER CAGE
126	X1789126	HAMMER PIN
127	X1789127	HAMMER DOG
128	X1789128	DRIVE CAM
129	X1789129	OIL SEAL
130	X1789130	BALL BEARING
131	X1789131	FRONT END PLATE
132	X1789132	ROTOR BLADE
133	X1789133	ROTOR
134	X1789134	SPRING PIN
135	X1789135	CYLINDER
136	X1789136	REAR END PLATE
137	X1789137	REAR GASKET
138	X1789138	REAR COVER
139	X1789139	SPRING WASHER
140	X1789140	CAP SCREW
141	X1789141	NAME PLATE
142	X1789142	RUBBER
143	X1789143	PROTECTING RUBBER
144	X1789144	STEEL BALL
145	X1789145	1/4 NPT AIR FITTING