



# Model 5276 Low Vibration Air Hammer

Form # ZCE701  
Date 5-02/A



<b>Operator Instructions</b> Includes – Foreseen Use, Work Stations, Putting Into Service, Operating, Dismantling, Assembly and Safety Rules.		<b>Important</b> Read these instructions carefully before installing, operating, servicing or repairing this tool. Keep these instructions in a safe accessible place.	
<b>Manufacturer/Supplier</b> Sioux Tools, Inc. 250 Snap-on Drive P.O. Box 1596 Murphy, NC 28906 U.S.A. Tel No. 828-835-9765      Fax No. 828-835-9685		<b>Product Type</b> Low Vibration Air Hammer	Max. BPM <b>3,300</b>
		<b>Model No/Nos</b> <b>5276</b>	<b>Serial No.</b>



<b>Product Net Weight</b> 5.10 lbs 2.32 kg	<b>Recommended Use Of Balancer Or Support</b> NO	<b>Recommended Hose Bore Size – Minimum</b> 5/16 ins    8 mm	<b>Recommended Max. Hose Length</b> 30 Ft    10 M
--	---	---	--

<b>Air Pressure</b> Recommended Working    6.2 bar    90 PSI Maximum                    6.2 bar    90 PSI		<b>Noise Level: Sound Pressure Level</b> 94.3 dB(A) <b>Sound Power Level</b> 106.6 dB(A)
		<b>Test Method: Tested in accordance with Pneurop test code PN8NTC1 and ISO Standard 3744</b>

<b>SAFETY MESSAGES</b> Personal Safety Equipment Use – Safety Glasses    YES Use – Safety Gloves    YES Use – Safety Boots Use – Breathing Masks    YES Use – Ear Protectors    YES	<b>WARNING</b> 	<b>Vibration Level</b> 9.56 Meters / Sec <sup>2</sup>  <b>Test Method: Tested in accordance with ISO standards 8662 Part 1</b>
---	--------------------	--

## Safety rules when using a 5276 Air Hammer

- Always wear safety goggles as use of tool may cause flying objects.
- Prolonged exposure to vibration may cause injury.
- Read all instructions before using this tool. All operators must be fully trained in its use and aware of these safety rules.
- Do not exceed the maximum working air pressure.
- Use personal protection equipment as recommended.
- Some dust created by power sanding, sawing, grinding, drilling, and other construction activities contains chemicals known to cause cancer, birth defects and other reproductive harm.
- Use only compressed air at the recommended conditions.
- If the tool appears to malfunction, remove from use immediately and arrange for service and repair. If it is not practical to remove tool from service, then shut off the air supply to the tool and write or have written a warning note and attach it to the tool.
- If tool is to be used with a balancer or other suspension device, ensure that the tool is firmly attached to the suspension/support device.
- When operating the tool, always keep the body and particularly the hands away from the working attachment

- fixed to the tool.
- The tool is not electrically insulated. Never use the tool if there is any chance of coming into contact with live electricity.
- Always when using the tool, adopt a firm footing and/or position and grip the tool sufficiently only to overcome any reaction forces that may result from the tool doing work. Do not overgrip.
- Use only correct spare parts for maintenance and repair. Do not improvise or make temporary repairs. Major servicing and repairs should only be carried out by persons trained to do so.
- Do not lock, tape, wire, etc. the 'On/Off' valve in 'On' position. The trigger/lever, etc. must always be free to return to the 'Off' position when released.

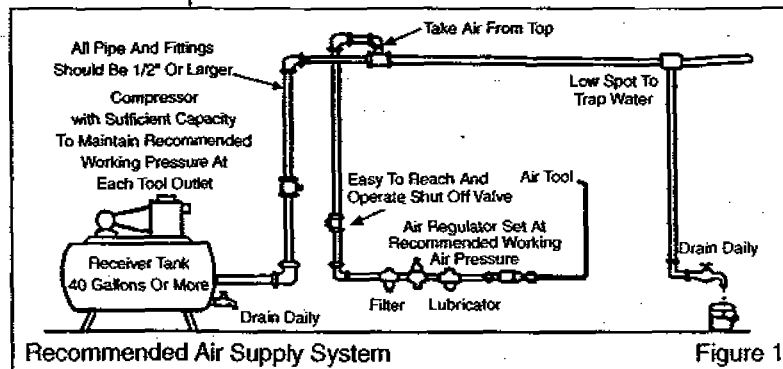

- Always shut off the air supply to the tool and press the 'On/Off' valve to exhaust the air from the feed hose before fitting, removing or adjusting the working attachment fitted to the tool.
- Before using the tool, make sure that a shut off device has been fitted to the air supply line and the position is known and easily accessible so that the air supply to the tool can be shut off in an emergency.
- Check hose and fittings regularly for wear.
- Take care against entanglement of the moving parts of the tool with clothing, hair, ties, cleaning rags, rings, jewelry, watches, bracelets, etc. This could cause the body or parts of the body to be drawn towards and in contact with the moving parts of the tool and could be very dangerous.
- It is expected that users will adopt safe working practices and observe all local, regional and country legal requirements when installing, using or maintaining the tool.
- Take care that the exhaust air does not point towards any other person or material or substance that could be contaminated by oil droplets. When first lubricating a tool or if the tool exhaust has a high oil content, do not allow the exhaust air to come near very hot surfaces or flames.
- Never lay the tool down until the working attachment has stopped moving.
- When the tool is not in use, shut off the air supply and press the trigger/lever to drain the supply line. If the tool is not to be used for a period of time, first lubricate, disconnect from air supply and store in a dry average room temperature environment.
- If the tool is passed from one user to a new or inexperienced user, make sure these instructions are passed with the tool.
- Do not remove any manufacturer fitted safety devices where fitted, i.e., wheel guards, safety trigger, speed governors, etc.
- Wherever possible, secure workpiece with clamps, a vise, etc. to make it rigid so it does not move during the work operation. Keep good balance at all times. Do not stretch or overreach.
- Try to match the tool to the work operation. Do not use a tool that is too light or heavy for the work operation. If in doubt, seek advice.
- In general terms, this tool is not suitable for underwater use or use in explosive environments — seek advice from manufacturer.
- Try to make sure that the work area is clear to enable the work task to be performed safely. If practical and possible, try to clear unnecessary obstructions before starting work.
- Always use air hose and couplings with minimum working pressure ratings at least 1 1/2 times the maximum working pressure rating of the tool.

## Foreseen Use Of The Tool – 5276

This tool is designed for the purpose of chipping, riveting and scaling of metals and stone. In general terms, a reciprocating free piston in the cylinder of the tool imparts a blow to the chisel or working attachment. A list of suitable equipment to use with this tool can be provided by the manufacturer. Do not use the tool for any other purpose than that for which it was designed without first consulting the manufacturer or the manufacturer's authorized representative. Do not modify the tool even for its use as a chipper, etc. or for any other purpose without first consulting the manufacturer or his authorized representative.

## Work Stations

The tool should only be used as a handheld, hand operated tool. It is always recommended that the tool is used when standing on a solid floor. It can be used in other positions, but before any such use, the operator must be in a secure position having a firm grip and footing and be aware of the extra safety precautions that must be observed when using the air hammer

## Putting Into Service

### Air Supply

Use a clean lubricated air supply that will give a measured air pressure at the tool of 90 p.s.i./6.2 bar when the tool is running with the trigger/lever fully depressed. Use recommended hose size and length. It is recommended that the tool is connected to the air supply as shown in figure 1. Do not connect the tool to the air line system without incorporating an easy to reach and operate air shut off valve. The air supply should be lubricated. It is strongly recommended that an air filter, regulator, lubricator (FRL) is used as shown in Figure 1 as this will supply clean, lubricated air at the correct pressure to the tool. Details of such equipment can be obtained from your supplier. If such equipment is not used, then the tool should be lubricated by shutting off the air supply to the tool, depressurizing the line by pressing the trigger/lever on the tool. Disconnect the air line and pour into the hose adaptor a teaspoonful (5ml) of a suitable pneumatic motor lubricating oil preferably incorporating a rust inhibitor. Reconnect tool to air supply and run tool slowly for a few seconds to allow air to circulate the oil. If tool is used frequently, lubricate on daily basis and if tool starts to slow or lose power.

It is recommended that the air pressure at the tool while the tool is running is 90 psi/6.2 bar.

## Operating

With the air supply disconnected, select the appropriate chisel attachment to perform the work task. The Quick Change Chuck (25) is designed to accept only 0.401" (10.2 mm) diameter round shank chisels. They can be quickly attached as follows. Screw the Quick Change Chuck (25) on the threaded end (tapered) of the cylinder (22). Using a hex wrench, tighten the three hex screws in the base of the chuck against the cylinder to prevent the turning of the chuck due to vibration. Then, to install a chisel, pull the textured ring on the chuck back towards the cylinder, insert chisel until bit collar passes the four steel balls. Release textured ring and make sure the chisel is locked in place.

To use the spring retainer, screw the spring clockwise on the threaded barrel. Insert the chisel through the spring from the drive end. The small end of the spring must face the working end of the chisel. Move it to one side, allowing it to grip the outer shoulder flange of the chisel bit.

Never fit or remove a chisel with the air supply connected as, accidental starting could cause the chisel to fly out of the tool causing serious injury.

The trigger (15) is the on/off valve for the tool. The power regulator (7) on the bottom of the handle regulates the flow of compressed air fed to the piston, which regulates the blow rate and the power of each blow.

An air strainer is built into the air inlet bushing (4). This should be checked periodically for blockage, particularly if the tool appears to lose power. It can be cleaned by removing air inlet bushing (4).

## Dismantling & Assembly Instructions

Disconnect tool from air supply.

Pull textured ring on the back of Quick Change Chuck (25) toward cylinder and take out chisel as fitted. Unscrew the Quick Change Chuck (25). By using a 3 mm hex wrench, unscrew set screw (2). Grip housing (1) in a vise fitted with soft jaws and unscrew clamping cover (23). Pull out the cylinder assembly (17) to (22) from housing (1) and remove the cushion spring (16). Unscrew the cylinder (22) from the cylinder sleeve (18). If it is difficult to unscrew cylinder (22) and clamping cover (23), use an extension bar on the spanner and/or provide local heating to the threaded area to soften and break the grip of the thread locking sealant.

Remove valve block assembly (19) from cylinder (22). Separate piston (21), spacer washer (20), and O-rings (17). Unscrew inlet bushing (4), remove roll pin (3) to allow air regulator (7) to be pulled out completely with O-rings (6) and cap (5). Tap out roll pin (3) and pull out the trigger assembly. Grip valve stem (9) and pull off trigger button (15). This could release the valve parts: spring (14), O-ring (11), valve bushing (12), O-ring (13), O-ring (10) and O-ring (8).

## Reassembly

Clean all parts and examine for wear. Replace any components with parts obtained from the manufacturer or authorized distributor. Coat all parts with a suitable pneumatic lubricating oil and then reassemble in the reverse order. Fit chisel or attachment as required.

Operation Specification	
Average Air Consumption	2.0 cfm (14 scfm)
Piston Stroke	2-5/8" (66 mm)
Chuck Bit Size	0.401" (10.2 mm) Dia. Shank Only
Bore Diameter	3/4" (19 mm)
Air Inlet Thread	1/4-18NPT
Length (with Q.C. Chuck)	10" (254 mm)
at 90 PSIG /6.2 bar	

## NOTES

## NOTES

CE

### Declaration of Conformity

**Sioux Tools Inc.**

**250 Snap-on Drive, P.O. Box 1596, Murphy, NC 28906, U.S.A.**

declare under our sole responsibility that the product

**Model 5276 Air Hammer, Serial Number**

to which this declaration relates is in conformity with the following standard(s) or other normative document(s)

**EN792 (Draft), EN292 Parts 1 & 2, ISO 8662 Part 1, Pneurop PN8NTC1**

following the provisions of **89/392/EEC as amended by 91/368/EEC & 93/44/EEC Directives**

*Gerald E. Seebeck*  
**Gerald E. Seebeck (President)**

Name and signature or equivalent marking of authorized person



# 5276 Low Vibration Air Hammer

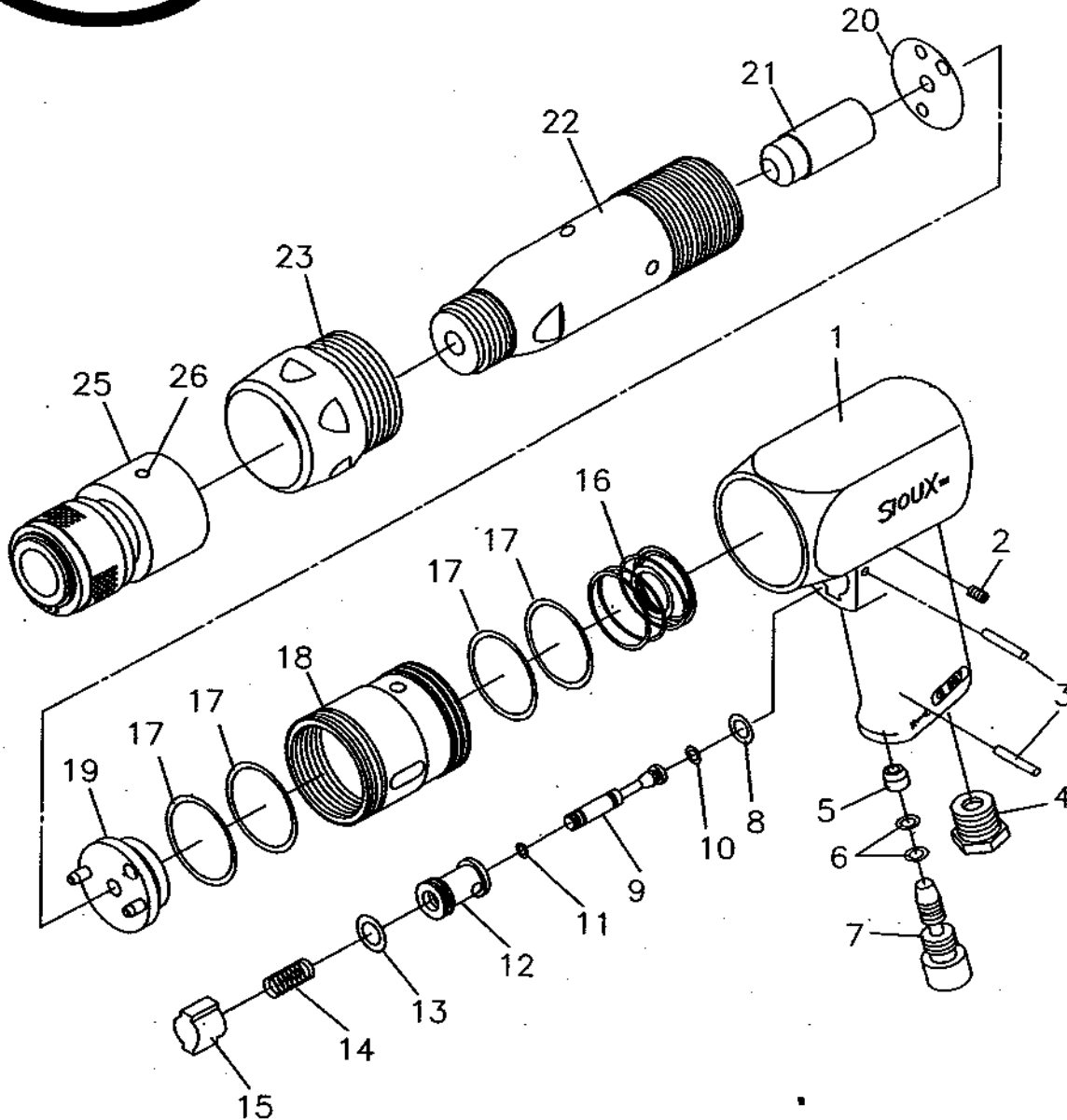

Ref. No.	Part No.	Description
1	506291	Housing
2	506292	Set Screw
3	66468	Roll Pin (2)*
4	505465	Inlet Bushing
5	505466	Cap
6	505467	O-Ring (4.9 x 2.2 mm) (2)*
7	505468	Regulator
8	505469	O-Ring (11 x 2.4 mm)
9	505470	Valve Stem
10	505471	O-Ring (3.8 x 1.9 mm)
11	66462	O-Ring (3.5 x 1.5 mm)
12	505472	Valve Bushing
13	66465	O-Ring (12 x 2 mm)
14	506474	Spring

Ref. No.	Part No.	Description
15	505475	Trigger Button
16	506293	Cushion Spring
17	506294	O-Ring (42 x 2 mm) (4)*
18	506295	Cylinder Sleeve
19	506270	Valve Block Assembly
20	506271	Spacer Washer
21	505482	Piston
22	505485	Cylinder
23	506296	Clamping Cover
25	2270	Quick Change Chuck
26	506396	Set Screw (3)*
Not Shown	506287	Retaining Spring
Not Shown	505488	Warning Icon Label

\*Order Quantity as Needed