

# Service Manual

## Cordless Impact Driver

### EY6506-U1

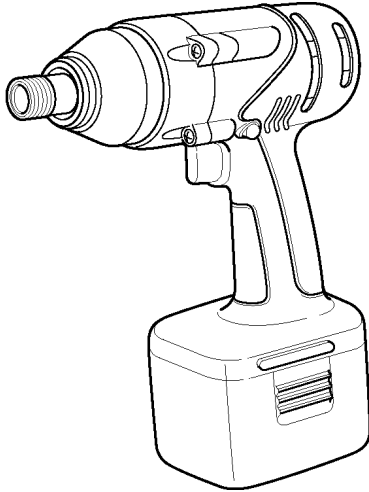

## SPECIFICATIONS

### MAIN UNIT

Motor	DC Motor 12V
No load speed	0-2800/min (rpm)
Maximum torque	98.0Nm (1000kgf-cm, 867in-lbs.)
Impact per minute	0-3000 ipm in Impact Mode
Overall length	155mm (6-1/8")
Weight (with battery pack)	1.45kg (3.2lbs.)

### **⚠ WARNING**

This service information is designed for experienced repair technicians only and is not designed for use by the general public. It does not contain warnings or cautions to advise non-technical individuals of potential dangers in attempting to service a product. Products powered by electricity should be serviced or repaired only by experienced professional technicians. Any attempt to service or repair the product or products dealt with in this service information by anyone else could result in serious injury or death.

## CONTENTS

	Page		Page
1 SCHEMATIC DIAGRAM .....	2	4 TROUBLESHOOTING GUIDE .....	5
2 WIRING CONNECTION DIAGRAM .....	2	5 EXPLODED VIEW .....	7
3 DISASSEMBLY/ASSEMBLY INSTRUCTIONS .....	3	6 REPLACEMENT PARTS LIST .....	8

# Panasonic®

© 2003 Matsushita Electric Works Ltd. All rights reserved. Unauthorized copying and distribution is a violation of law.

# 1 SCHEMATIC DIAGRAM

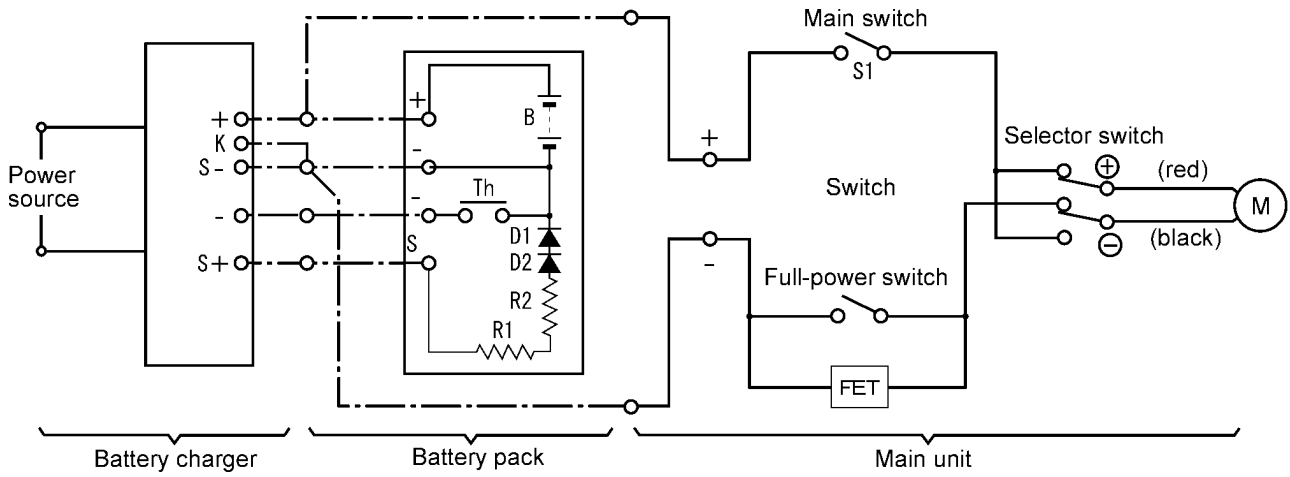

# 2 WIRING CONNECTION DIAGRAM

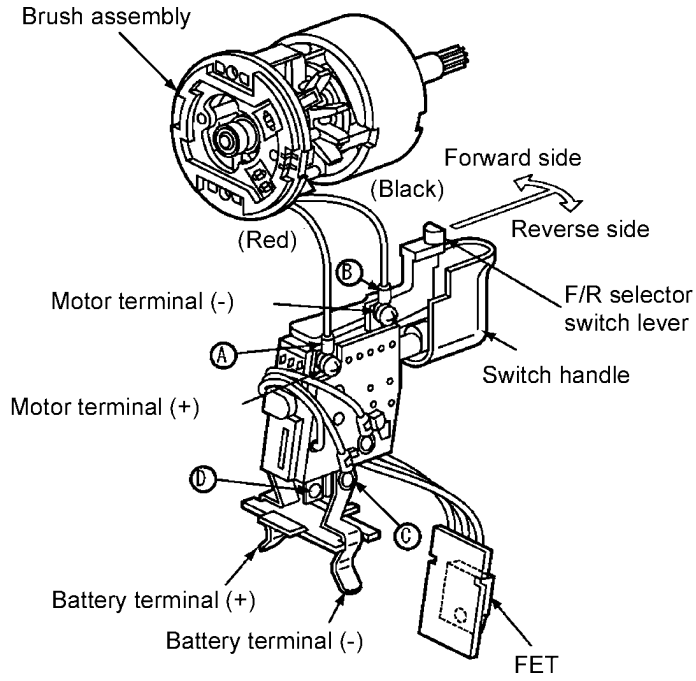

### 3 DISASSEMBLY/ASSEMBLY INSTRUCTIONS

#### ■HOW TO DISASSEMBLE MAIN UNIT.

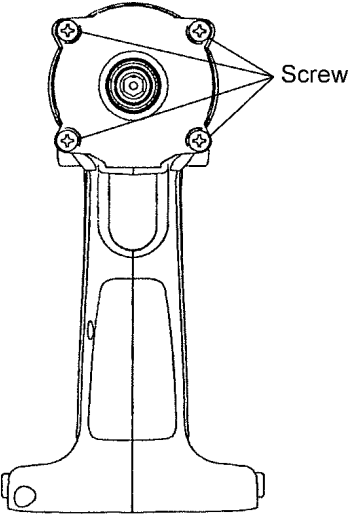
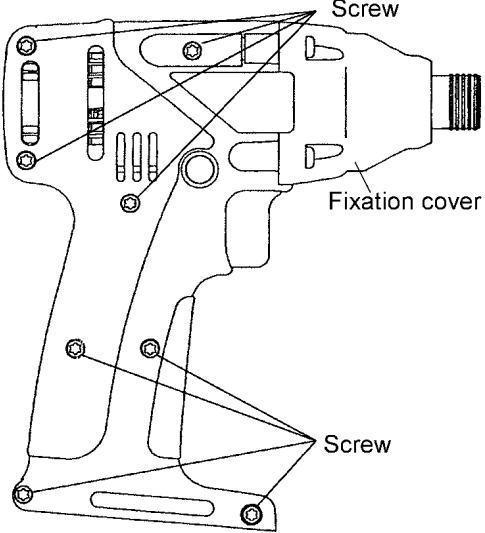
Ref. No. 1A	Procedure 1A	Removal of the Fixation cover and Housing.
		<ol style="list-style-type: none"> <li>1. Remove four screws tightened with the fixation cover and take it out.</li> <li>2. Remove eight housing screws.</li> </ol> 

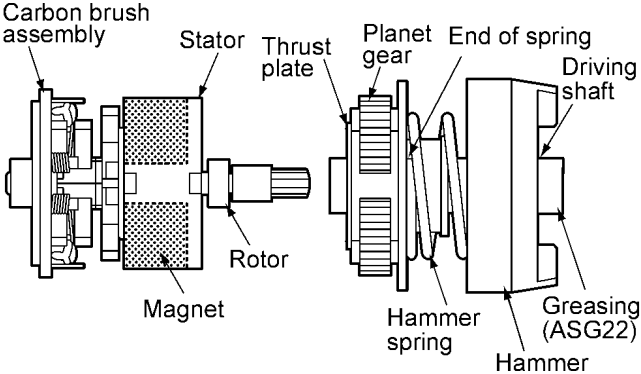
Ref. No. 1B	Procedure 1A → 1B	Removal and attachment of the Motor.
		<p>(Removal)</p> <ol style="list-style-type: none"> <li>1. Take out the motor with the driving block from housing.</li> <li>2. Separate the motor assembly from the driving block.</li> <li>3. Take out the motor rotor assembly from the motor stator.</li> </ol> <p><b>NOTE :</b> Make sure not to damage the magnet by motor rotor.</p> <p>(Attachment)</p> <ol style="list-style-type: none"> <li>1. Insert the motor rotor assembly into the stator.</li> </ol> <p><b>NOTE :</b> Make sure that the motor stator has their own direction for proper assembly. If it is assembled wrongly, the rotation may be the opposite way.</p>

Ref. No. 1C

Procedure 1A → 1B → 1C

Removal of the Driving Block.

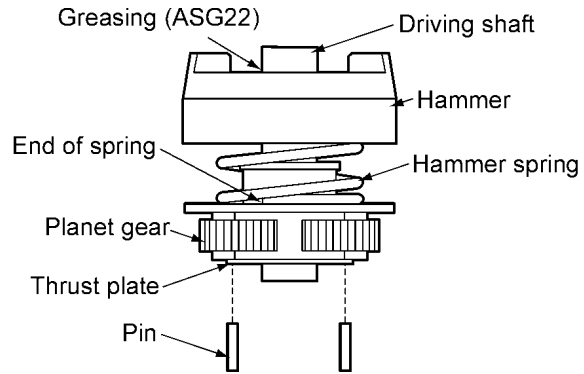

1. Remove the thrust plate.
2. Take out the planet gears and pins slightly tapping the driving block on the table.

Ref. No. 1D

Procedure 1A → 1B → 1C → 1D

Assembly of the Switch.

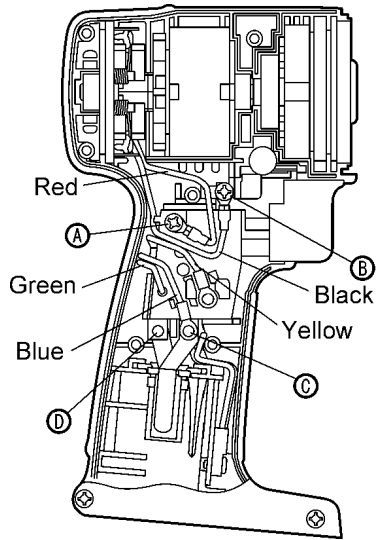

1. Press fit the lead wires firmly.

# 4 TROUBLESHOOTING GUIDE

(Refer to WIRING CONNECTION DIAGRAM)

< TROUBLE >	< CHECK >	< REMEDY >	
Does not operate.	<p align="center">&lt;CHECK BATTERY PACK.&gt;</p> <p>If no less than 12V DC is available across the (+) and (-) terminals, the battery pack is OK.</p> <p><b>NOTE:</b> The battery pack is sold separately as an optional accessory. See the nearest sales dealer for details. The battery pack has a limited life.</p> <p>The pack should be replaced if;</p> <ul style="list-style-type: none"> <li>- after being charged for the rated charging time the battery voltage is less than 12V DC or the usable time is extremely short.</li> <li>- the battery leaks. Check battery for leaks and terminals for corrosion.</li> </ul>	NO → Replace battery pack.	
↓OK			
<p align="center">&lt;CHECK TERMINAL CONNECTIONS BETWEEN MAIN UNIT AND BATTERY PACK.&gt;</p> <p>Check for proper terminal contacts.</p>			NO → Repair contacts.
↓OK			
<p align="center">&lt;CHECK SWITCH BLOCK.&gt;</p> <p align="center">(See WIRING CONNECTION DIAGRAM.)</p> <p>Check continuity between following terminals.</p> <p>* Inspection of the forward / reverse selection switch.</p> <p>When switch handle is depressed all the way:</p> <ul style="list-style-type: none"> <li>- There should be 0Ω between (A) - (D) , and between (B) - (C) ; when switch lever is set to forward side.</li> <li>- There should be 0Ω between (A) - (C) , and between (B) - (D) ; when switch lever is set to reverse side.</li> </ul> <p>* Inspection of the brake.</p> <p>When switch handle is not depressed:</p> <ul style="list-style-type: none"> <li>- There should be 0Ω between (A) - (B) .</li> </ul>			NO → Contacts in switch block are defective. Replace switch & FET block.
↓OK			
<p align="center">&lt;CHECK MOTOR BRUSH.&gt;</p> <p>A. Check the condition of carbon brush. (Do not touch between brush holder and holding spring.)</p> <p>B. There should be 0Ω between motor lead wire and terminal of brush holder.</p>			NO → Replace motor brush assembly.
↓OK			
<p align="center">&lt;CHECK MOTOR ROTOR.&gt;</p> <p>Check the condition of rotor if there is any wear, crack and deformation.</p>			NO → Replace motor rotor assembly.
↓OK			
<p align="center">&lt;CHECK MOTOR STATOR.&gt;</p> <p>Check the condition of motor case if there is any crack and deformation.</p>			NO → Replace motor stator.

< TROUBLE >

Does not speed-control.



< CHECK >

<CHECK FET.>

Even if FET block is defective, it can not be replaced individually.  
 Replace whole switch block.  
 Remove the FET circuit block and check the lead wire terminals.  
 These terminals are open normally when there is an open circuit ( $\infty \Omega$ )  
 between the green and yellow lead wires, and between the blue and  
 yellow lead wires.

**NOTE:**

- \* FET is weak against static electricity.
- \*\* The resistance value may be some differences depends on the measurement range.

NO

< REMEDY >

Repair the contact  
 or replace switch  
 & FET block.



Does not vibrate  
 or weakness of  
 vibration.



<CHECK ANVIL.>

Check wear condition of anvil. If no less than 1mm from  
 the corner at (A) side or 0.5mm from the corner at (B) side,  
 anvil is OK.

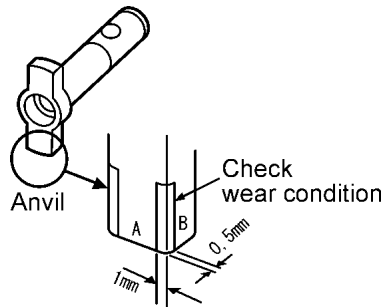

NO

Replace anvil.



# 5 EXPLODED VIEW

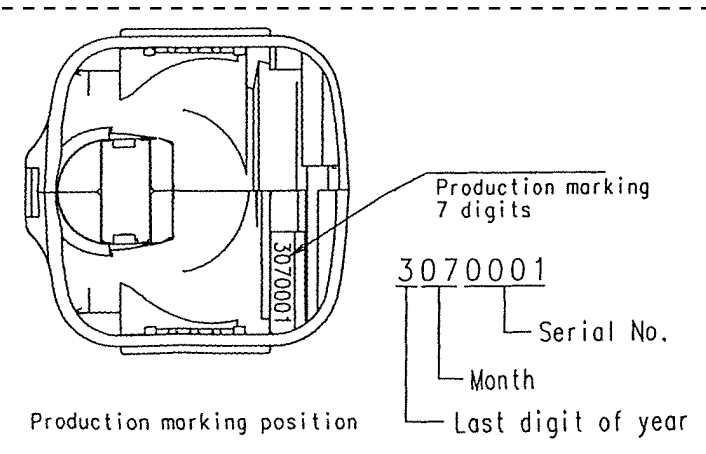
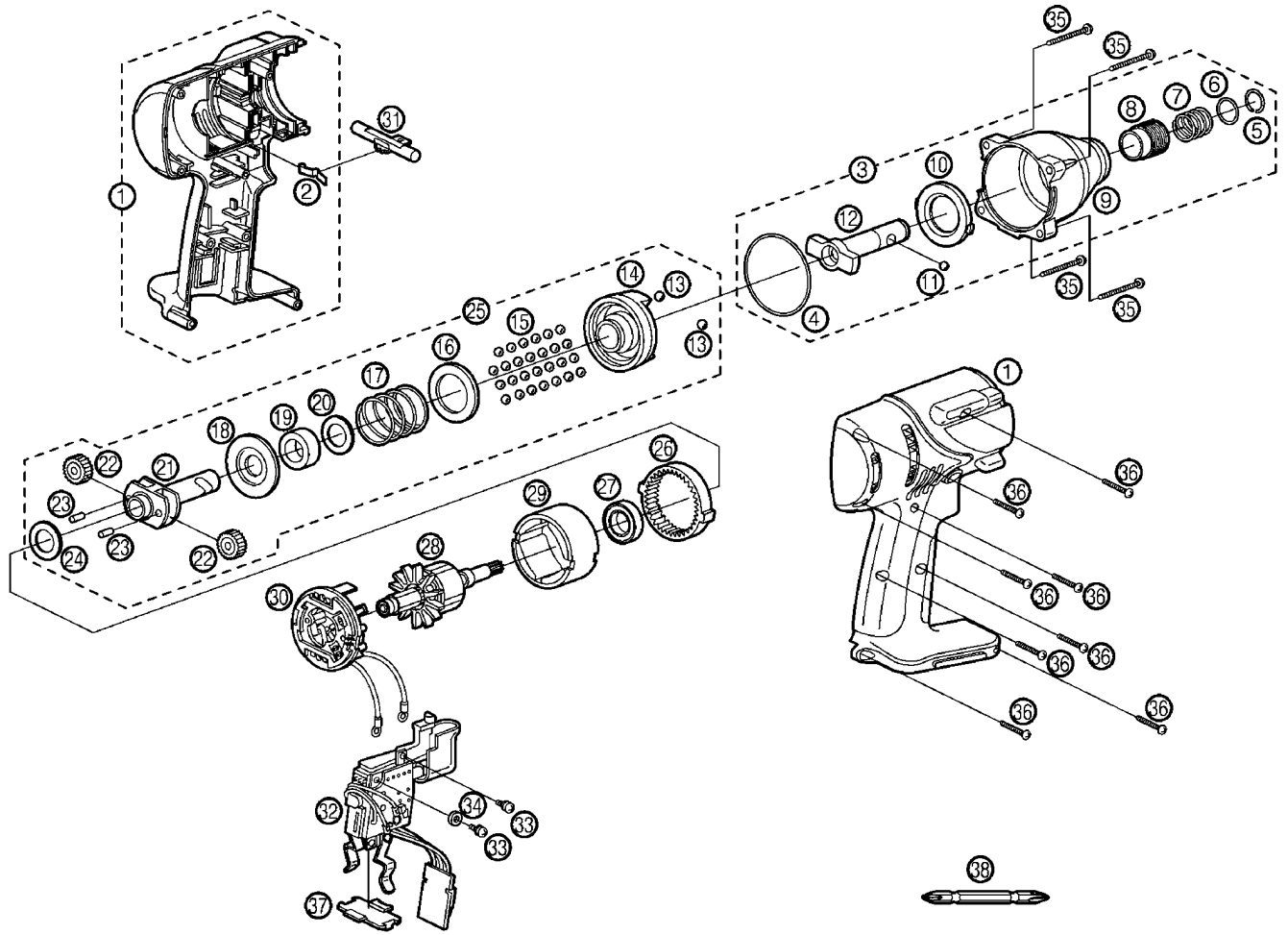

# 6 REPLACEMENT PARTS LIST

## NOTE:

\*B=only available as set

\*C=available individually

Ref.No.	Part No.	Part Name & Description	Remarks		Per Unit
1	WEY6506K3078	HOUSING AB SET			1
2	EY6481L0177	CLICK SPRING			1
3	WEY6506H4057	FIXATION COVER ASSEMBLY			1
4	WEY6504L0987	O-RING		Ø 47	1
5	WEY7300K1167	C-TYPE RING			1
6	WEY6605L0857	THRUST PLATE			1
7	WEY6605L0197	BIT HOLDER SPRING			1
8	WEY6404K3717	BIT HOLDER			1
9	WEY6506H3747	FIXATION COVER			1
10	WEY6505L0867	SLIDER			1
11	EY6225L6977	STEEL BALL		Ø 3.5	1
12	WEY6506L1127	ANVIL			1
13	WEY574B6967	STEEL BALL	*B	(2PCS/PK)	2
14	WEY6506L1377	HAMMER			1
15	WEY7300L6957	STEEL BALL	*B	(27PCS/PK)	27
16	WEY6506L0877	THRUST PLATE			1
17	WEY6506L0157	HAMMER SPRING			1
18	WEY6506L1147	SPRING FIXING PLATE			1
19	WEY6506L0317	DUST PREVENT RUBBER			1
20	WEY6506L0847	THRUST PLATE			1
21	WEY6506L1137	DRIVING SHAFT			1
22	WEY6506L1357	PLANET GEAR	*B	(2PCS/PK)	2
23	WEY6506L1347	PIN	*B	(2PCS/PK)	2
24	WEY6506L0837	THRUST PLATE			1
25	WEY6506L1067	DRIVING BLOCK			1
26	WEY6506L1457	RING GEAR			1
27	WEY6606L4957	BEARING			1
28	WEY6506L1467	MOTOR ROTOR ASSEMBLY			1
29	WEY6506L1187	STATOR			1
30	WEY6506L2308	BRUSH ASSEMBLY			1
31	WEY6506Y3247	F/R SELECTOR HANDLE			1
32	WEY6506Y2007	SWITCH			1
33	EY6261B6027	SEMS SCREW	*C	K3-5	2
34	WEY6506L0887	THRUST PLATE			1
35	WEY6506K9217	M-TIGHT SCREW	*C	K4-22	4
36	EY6230K9218	TORX TAPPING SCREW	*C	K3-20	▲ 8
37	EY6230L0207	DUST PREVENTIVE PLATE			▲ 1
38	WEY6505X7928	PHILLIPS BIT		(+) 65mm	1
-	WEY6506K8108	OPERATING INSTRUCTIONS			▲ 1

\*\*Battery Pack, and Tool Case are available as an optional accessory.

See the nearest sales dealer for details.

\*\*\*For replacement parts of charger, see the charger service manual.

Charger complete set is available as an optional accessory. See the nearest sales dealer for details.