



---

# OWNER'S OPERATING MANUAL

---

**VIRTUAL**<sup>TM</sup>  
HIGH DEFINITION

**PRELIMINARY**

**VHD-4402 ULTRA**

*Virtual High Definition Processor With Aspect Ratio Control*



**THE WORLD'S FINEST HOME THEATER PRODUCTS<sup>TM</sup>**





---

# OWNER'S OPERATING MANUAL

---

**VIRTUAL**<sup>TM</sup>  
HIGH DEFINITION

**PRELIMINARY**

**VHD-4402 ULTRA**

*Virtual High Definition Processor With Aspect Ratio Control*



**THE WORLD'S FINEST HOME THEATER PRODUCTS<sup>TM</sup>**

The software installed in the VHD-4402 ULTRA is protected by copyright laws and International copyright treaties, as well as other intellectual property laws and treaties.

**IMPORTANT - READ CAREFULLY:** This Runco License Agreement is a legal agreement between you (either an individual or a single entity) and Runco International for the Runco software product installed within the VHD-4402 ULTRA. By using the VHD-4402 ULTRA, you agree to be bound by the terms of this License Agreement. If you do not agree to the terms of this License Agreement, do not use the VHD-4402 ULTRA; you may, however, return it to your place of purchase.

© 2000, Runco International. All rights reserved.

# CONTENTS

---

<b>Warnings and Safety Precautions</b> .....	<b>4</b>
<b>Introduction</b> .....	<b>6</b>
General Description .....	6
Features and Benefits .....	6
<b>Front and rear panel description</b> .....	<b>7</b>
Front Panel Description .....	7
Rear Panel Description .....	8
Remote Control Description .....	10
<b>Quick Set-up Guide</b> .....	<b>11</b>
Connection Examples .....	11
Getting Started .....	12
Overall Function Description .....	13
<b>Menu Description and Navigation</b> .....	<b>14</b>
Main Menu .....	14
Picture Quality Adjustments .....	15
<b>Aspect Ratios</b> .....	<b>18</b>
First the Basics .....	19
<b>Dimensions</b> .....	<b>20</b>
<b>RS-232 Protocol</b> .....	<b>21</b>
<b>Specifications</b> .....	<b>22</b>
Supplied Accessories .....	22

# Warnings and Safety Precautions

---

---

**CAUTION:**

To turn off main power, be sure to remove the plug from power outlet. The power outlet socket should be installed as near to the equipment as possible, and should be easily accessible.

---

**REMARQUE:**

Pour mettre l'appareil hors circuit, s'assurer de retirer la fiche de la prise d'alimentation. La prise d'alimentation doit être installée aussi proche que possible de l'appareil et doit être facile d'accès.

---

 **WARNING**

TO PREVENT FIRE OR SHOCK HAZARDS, DO NOT EXPOSE THIS UNIT TO RAIN OR MOISTURE. ALSO DO NOT USE THIS UNIT'S POLARIZED PLUG WITH AN EXTENSION CORD RECEPTACLE OR OTHER OUTLETS, UNLESS THE PRONGS CAN BE FULLY INSERTED. REFRAIN FROM OPENING THE CABINET AS THERE ARE HIGH-VOLTAGE COMPONENTS INSIDE. REFER SERVICING TO QUALIFIED SERVICE PERSONNEL.

 **AVERTISSEMENT**

POUR EVITER UN FEU OU UN RISQUE D'ELECTROCUTION NE PAS EXPOSER CET ENSEMBLE A LA PLUIE OU A L'HUMIDITE; DE MEME, NE PAS BRANCHER LA PRISE POLAIRE AVEC UNE RALLONGE A MOINS QUE LES DENTS DE LA PREMIERE NE S'Y INSERENT PLEINEMENT.

EVITER D'OUVRIR LE COFFRET CAR IL Y A, A L'INTERIEUR, DES COMPOSANTS SOUMIS A UNE HAUTE-TENSION; POUR LES REPARATIONS, S'ADRESSER A UN PERSONNEL QUALIFIE.

**WARNING:**

This equipment has been tested and found to comply with the limits for a Class B digital device, pursuant to Part 15 of the FCC Rules. These limits are designed to provide reasonable protection against harmful interference when the equipment is operated in a commercial environment. This equipment generates, uses, and can radiate radio frequency energy and, if not installed and used in accordance with the installation manual, may cause harmful interference to radio communications. Operation of this equipment in a residential area is likely to cause harmful interference, in which case, the user will be required to correct the interference at his own expense.

---

**DOC compliance Notice**

This Class B digital apparatus meets all requirements of the Canadian Interference-Causing Equipment Regulations.

---

**DOC avis de conformation**

Cet appareil numérique de la classe B respecte toutes les exigences du Règlement sur le Matériel D'interférence du Canada.

**Safety Tips:**

Please read and follow the safety precautions listed below to ensure the equipment is free from damage, and to ensure that no injury will occur as a result of improper use.

- Do not insert any object, especially metal or liquids, into the VHD-4402 ULTRA.
- Do not place any objects containing water or any other liquid on top of the VHD-4402 ULTRA
- Do not place the unit in direct sunlight, near heaters or in extremely dusty or humid locations
- Do not install this unit outdoors or otherwise exposed to the elements
- Do not place heavy objects on top of the unit
- If the power cord is damaged or frayed in any way, electrical shock and/or fire may result. Please do not place objects on the power cord, and keep the cord away from heat-emitting devices. Should the power cord become damaged in any way, please contact your Runco dealer for a replacement cord.
- Do not remove the cover of the unit for any reason. If any problems arise with the unit, please contact a Runco dealer or Runco International for service. Removing the cover will void the warranty.

# INTRODUCTION

---

## General Description

Congratulations on your purchase of the VHD-4402 ULTRA! This processor is designed to work with either a CRT projector or a fixed-pixel device (DLP, Plasma, etc.), and will provide full aspect ratio control as well as greatly enhanced picture quality. For example, DLP projectors were not initially designed to be used on wide aspect-ratio screens (16:9 or 1.85:1). The VHD-4402 ULTRA, however, expands the use of the DLP projector to be able to accommodate Letterbox, anamorphic (16:9) and 4:3 images on your wide-aspect ratio screen. This allows you to use the full benefit of your widescreen without having to sacrifice aspect ratio control. When using the VHD-4402 ULTRA with a CRT projector (i.e. DTV-940), the aspect ratio control feature allows the projector to stay in a single memory, making integration into the system much easier.

The VHD-4402 ULTRA is not only an aspect-ratio controller, but is also scaler with a progressive output, which virtually eliminates motion artifacts as a result of interlaced signals. Also, its 10-bit processing results in the cleanest, most resolved video images a processor can provide.

This preliminary version of the VHD-4402 you have just received has all of the features noted above, and has a scan rate output (38 kHz) optimized for the Runco projector you have purchased with it. This processor will be upgradeable in the future; these upgrades include multiple scan rate outputs and the ability to optimize the output for either CRT projectors or fixed pixel devices. This upgrade will either be in the form of an exchange with a fully upgraded unit, or a software upgrade which involves a simple chip replacement. Please contact Runco for more updated information regarding these upgrades.

## Features and Benefits

The VHD-4402 ULTRA has many great features and benefits that make it a flexible, high-quality processor. Its many benefits include:

- An adaptive 2-dimensional comb filter that greatly reduces artifacts when using a composite video signal as an input.
- A Luma edge enhancement circuit makes the edges of objects appear sharper without the ringing and noise increase associated with traditional sharpness circuits
- A Chroma edge enhancement circuit is included to compensate for lower chroma resolution found in composite and S-video.
- Inverse Telecine (3:2 pulldown) detection and processing allows the scaler to almost completely eliminate interlace artifacts associated with other scalers
- The controller can correctly scale anamorphic, letterbox and 4:3 formats to fit on a wide aspect-ratio screen, and scale anamorphic formats on a 4:3 screen
- A pass-through connector is supplied for routing HDTV or computer graphics directly to the projector.
- An RS-232 input is provided for easy integration into the automated home theater environment
- A TBC (Time Base Corrector) circuit is provided for unstable sources such as VCR's.
- A Dual-Screen actuator output for both Widescreens and 4:3 screens is provided
- A simple 7-button remote controls all aspects of operation. One button source selection and aspect ratio control is also provided via the remote control or the front panel.



# FRONT AND REAR PANEL DESCRIPTIONS \_\_\_\_\_

## Front Panel

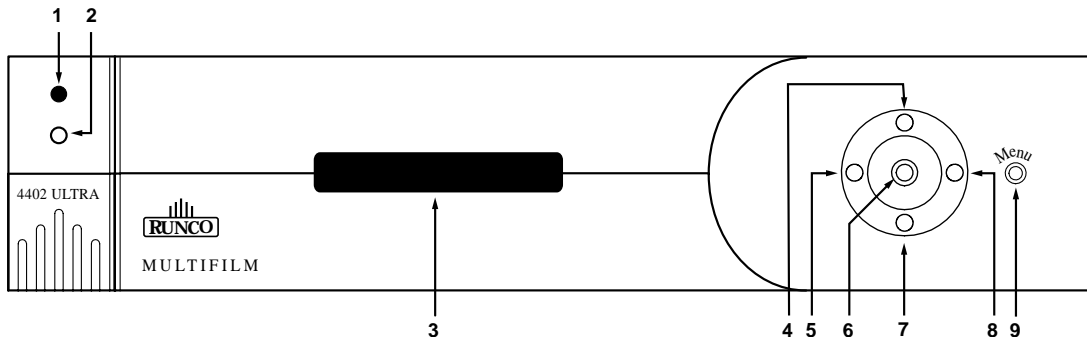

### 1. IR RECEIVER

Receives the IR commands from the remote control.

### 2. MENU BUTTON

The MENU button brings up the main adjustment menu. After making adjustments, the MENU button will bring you back to the sub-menu, then the main menu. The Menu will then either time-out after approximately 10 seconds, or pressing the MENU button will remove the menu immediately.

### 3. LCD DISPLAY

Indicates the function or active adjustments and current scan rate.

### 4. UP BUTTON

When no menu is present on-screen, this button will toggle you through the different aspect ratios.

When the menu is on-screen, the up button will move the cursor up within a menu.

### 5. LEFT BUTTON

When no menu is present on-screen, this button will toggle you through the four different sources, in the order of:  
—► COMPOSITE —► S-VIDEO —► COMPONENT —► PASS THROUGH

When an adjustment function has been selected (i.e. Brightness), the LEFT button will decrease the value of that function.

### 6. ENTER BUTTON

When an item is highlighted on the On-Screen Display, the ENTER button will select the item.

### 7. DOWN BUTTON

When no menu is present on-screen, this button will toggle you through the different aspect ratios.

When the menu is on-screen, the down button will move the cursor down within a menu.

### 8. RIGHT BUTTON

When no menu is present on-screen, this button will toggle you through the four different sources, in the order of:  
—► PASS THROUGH —► COMPONENT —► S-VIDEO —► COMPOSITE

When an adjustment function has been selected (i.e. Brightness), the RIGHT button will increase the value of that function.

### 9. POWER BUTTON

Turns the unit on. The MAIN POWER switch on the rear of the unit must be on first for this button to be active.

## Rear Panel

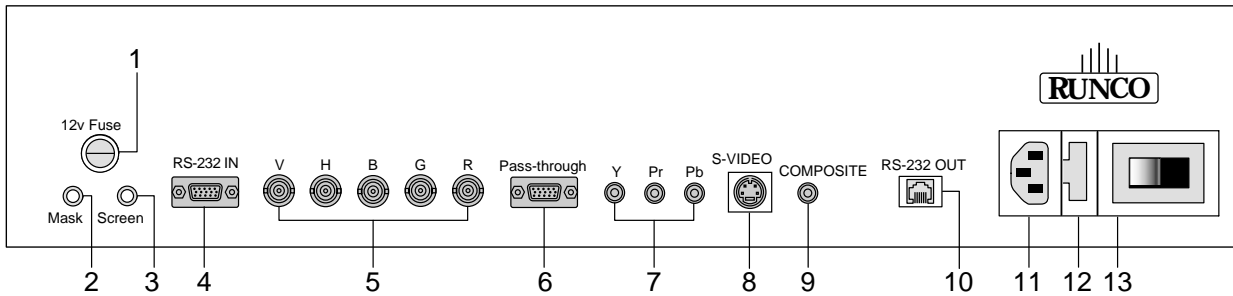

### 1. 12v Fuse

This fuse protects the 12v outputs from the MASK and SCREEN jacks. (Screen Fuse: 5mm x 25mm, AGC, 1A, 250v, Fast Blow)

### 2. Mask

This is a 12V output that is used to trigger masking on screens that have that capability (For use on motorized screens only).

### 3. Screen

This is a 12V output that is used to trigger the screen to drop (For use on motorized screens only).

### 4. RS-232 In

This is for systems using serial (RS-232) to control the VHD-4402 ULTRA. Please refer to the RS-232 Protocol section at the end of this manual for information.

### 5. RGB OUTPUT

This is the main output of the VHD-4402 ULTRA. The RGB Signal goes directly to the VX projector; If component is used through the pass-through, then only the R (Pr), G(Y) and B(Pb) jacks will be active. Individually, the jacks are: V=vertical sync, H=horizontal sync, B=Blue, G=Green, R=Red.

### 6. Pass-through

Anything input to this jack will by-pass the processing of the VHD-4402 ULTRA and be sent straight to the projector. This is useful for computer graphics and HDTV which do not require processing.

### 7. Component Input

This is the input for component video from sources such as DVD players.

#### Note:

The component output from a DTV decoder or a progressive-scan DVD cannot be used with this jack; it must be used with the Pass-through.

### 8. S-Video Input

This is the input for S-video from sources such as Satellite receivers, S-VHS VCR's and DVD players.

### 9. Composite Video Input

This is the input for Composite video from sources such as Laser disc players, VCRs and other miscellaneous sources.

## FRONT AND REAR PANEL DESCRIPTIONS

---

### 10. Phone Jack

The output of this jack must be connected to the PC Control input of the Projector. This communication will allow the controller and projector to be turned on simultaneously by turning on just the VHD-4402 ULTRA.

### 11. Power Input

Plug in main power here.

### 12. 115 VAC Fuse

This is the main AC input fuse.  
(Main Fuse: 5mm x 20 mm, 500mA, 250v, Slow Blow)

### 13. Main Power Switch

Disconnects or applies main power to the processor.

**Remote Control Description**

**A. LED**

Lights when a button is pressed indicating IR output.

**B. POWER BUTTON**

Turns the unit on. The MAIN POWER switch on the rear of the unit must be on first for this button to be active.

**C. UP BUTTON**

When no menu is present on-screen, this button will toggle you through the different aspect ratios.

When the menu is on-screen, the up button will move the cursor up within a menu.

**D. LEFT BUTTON**

When no menu is present on-screen, this button will toggle you through the four different sources, in the order of:

→ COMPOSITE → S-VIDEO → COMPONENT → PASS THROUGH

When an adjustment function has been selected (i.e. Brightness), the LEFT button will decrease the value of that function.

**E. DOWN BUTTON**

When no menu is present on-screen, this button will toggle you through the different aspect ratios.

When the menu is on-screen, the down button will move the cursor down within a menu.

**F. RIGHT BUTTON**

When no menu is present on-screen, this button will toggle you through the four different sources, in the order of:

→ PASS THROUGH → COMPONENT → S-VIDEO → COMPOSITE

When an adjustment function has been selected (i.e. Brightness), the RIGHT button will increase the value of that function.

**G. MENU BUTTON**

The MENU button brings up the main adjustment menu. After making adjustments, the MENU button will bring you back to the sub-menu, then the main menu. The Menu will then time-out after approximately 10 seconds, or pressing the MENU button will remove the menu immediately.

**H. ENTER BUTTON**

When an item is highlighted on the On-Screen Display, the ENTER button will select the item.

**I. PROGRAM BUTTON**

Reprogramming of the remote control with lost memory.

**J. DIRECT ACCESS BUTTONS**

These buttons are a shortcut that allow you to go directly to a particular source of Aspect Ratio, as well as provide discreet ON/OFF commands. These buttons are:

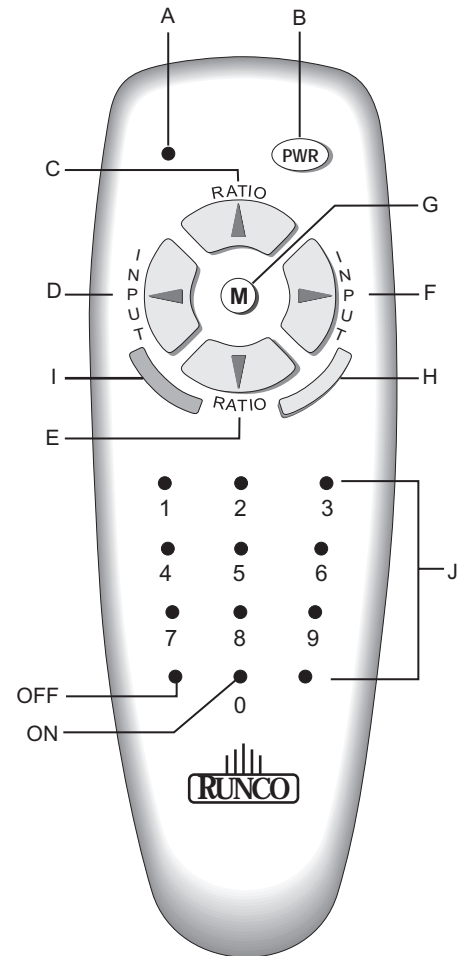

- 1. Composite Video Source Selection
- 2. S-Video Source Selection
- 3. Component Video Source Selection
- 4. Not used
- 5. Pass-Through
- 6. Not used
- 7. Anamorphic Aspect Ratio Selection
- 8. 4:3 Aspect Ratio Selection
- 9. Letterbox Aspect Ratio Selection

**ON:** Discreet ON Command

**OFF:** Discreet OFF Command

# Quick Set-up Guide

## Connection Examples

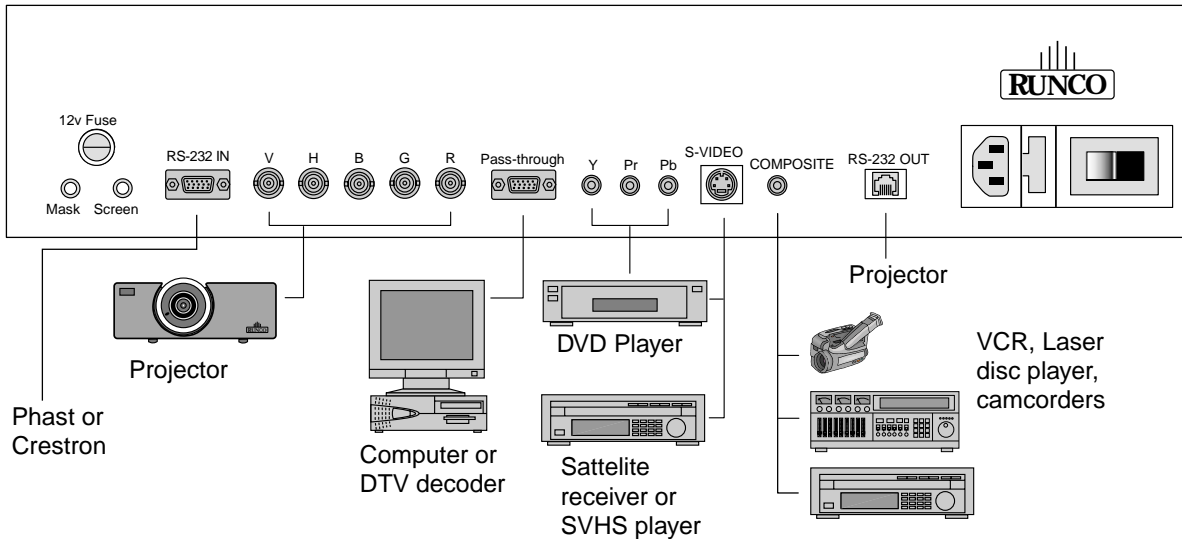

While there are many different ways to connect your source equipment to your VHD-4402 ULTRA, the examples shown above are the most common and are recommended by Runco.

### • COMPOSITE VIDEO INPUT:

Composite video is the most common type of signal used, but is also the lowest in picture quality. Many sources have outputs that are limited to composite video, such as most VCR's and some camcorders; others such as Laser Disc players actually produce slightly better results when using composite video. While the VHD-4402 ULTRA has an excellent decoder for composite video, it is recommended that composite video be used only if necessary.

### • S-VIDEO INPUT

S-video is the second-best type of signal that can be used, but is MUCH better than composite video. Using such sources as Satellite receivers, high-quality VCRs and DVD players (with no component output) will produce a MUCH cleaner and sharper signal. Decoder artifacts that are associated with composite video (dot crawl and 'rainbows') are non-existent when using S-video.

### • COMPONENT INPUT

Component video is the best type of signal that can be used. The most common sources that use component outputs are DVD players, and it is highly recommended that component be used when possible. Component video goes one step beyond S-video in picture quality; chroma (color) information is more resolved and the overall picture appears more well-defined.

### • PASS-THROUGH

This input is used to 'pass-through' any high-definition or computer signals that do not require processing. The signal by-passes the VHD-4402 ULTRA's processing and is sent directly to the projector. The pass-through may be used for COMPONENT outputs from a DTV decoder, a progressive-scan DVD player or RGB outputs from a computer.

## Getting Started

To get started using your VHD-4402 ULTRA and projector, follow these simple steps:

1. Ensure all sources that you are using are properly connected to the VHD-4402 ULTRA. This is something your Runco dealer has probably already done for you; if not, please refer to the 'Connection Examples' and the owners manuals of each appropriate source as necessary.
2. Turn on all sources. If a A/V receiver or a RUNCO OVSS-8 is being used to switch the video, ensure that is also turned on.
3. Turn on the VHD-4402 ULTRA. Make sure the Main Power switch (pg. 8) is ON, then press the power button on the front of the controller (or the power button on the remote). Ensure the red LED lights up on the front of the unit.
4. Turn on the projector.
5. With the left or right buttons on the front panel or remote, select the desired source. You may also do this by going through the menu (see pg. 14).
6. Select the desired aspect ratio by using the up and down buttons on the front panel or the remote. You may also do this by going through the menu. For an explanation of Aspect ratios, please refer to pg. 18.

**Overall Functional Description**

The VHD-4402 ULTRA's purpose is twofold. First, it provides aspect ratio control and can do so on either a WIDESCREEN or a standard 4:3 screen. Second, it provides a clean, progressive signal to the projector.

The processing the VHD-4402 ULTRA uses is called SCALING. Scaling is simply a way of taking a signal, 'digitizing' it, then converting it to any of a number of resolutions. It is by manipulating the algorithms of the scaling process that we are able to not only produce properly-configured aspect ratios, but to provide the most effective scan rate for the projector it will be used with.

An INTERLACED signal is the type of signal that comes from all consumer sources (with the exception of DTV decoders and computers). DVD players, Laser Disc players, and VCRs are all examples of source equipment that have interlaced outputs. An interlaced signal is simply described as this:

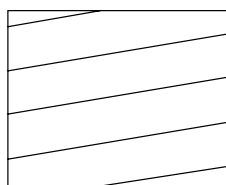

**240 lines (odd)**  
**First 1/60th of a second**

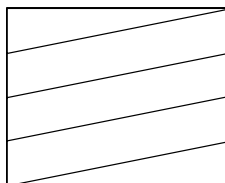

**240 lines (even)**  
**Second 1/60th of a second**

An NTSC picture is made of approximately 480 lines. Images are drawn 60 times a second, but in an interlaced system, only half the lines are drawn each 'pass'. Therefore, it takes two 'passes' to actually complete the picture. On the first 1/60th of a second, all of the 'ODD' lines are drawn, then the 'EVEN' lines the next 1/60th of a second. This is also called '480i', where 480 is the total number of lines of resolution, and 'i' means interlaced.

A PROGRESSIVE signal, however, draws all 480 lines each 1/60th of a second, not half and half like an interlaced signal. A 'line doubler', for example, outputs a 480-line progressive signal (also known as 480P). The line doubler takes the first field (odd lines), and stores them in memory, then takes the second field (even lines) and does the same. Then, all 480 are output at once, and then the same frame is repeated.

The VHD-4402 ULTRA starts off as a line doubler by 'de-interlacing' the signal. Then, the 480p signal is scaled to appropriate resolution, and then output to the projector. It is Runco's high-quality scaling process as well as its de-interlacing that provides the clean, resolved image that you see from your projector. It is also how the processor can provide aspect ratio control.

In the next chapter, the individual menu items will be described in detail. Overall, the VHD-4402 ULTRA has a number of useful functions aside from the scaling and de-interlacing described above. It has typical picture controls, including COLOR (saturation), TINT (hue), BRIGHTNESS (black level), SHARPNESS, CONTRAST (ratio of white to black) and other picture enhancements such as LUMA and CHROMA ENHANCE.

# MENU DESCRIPTION AND NAVIGATION

## Main Menu

### MAIN MENU

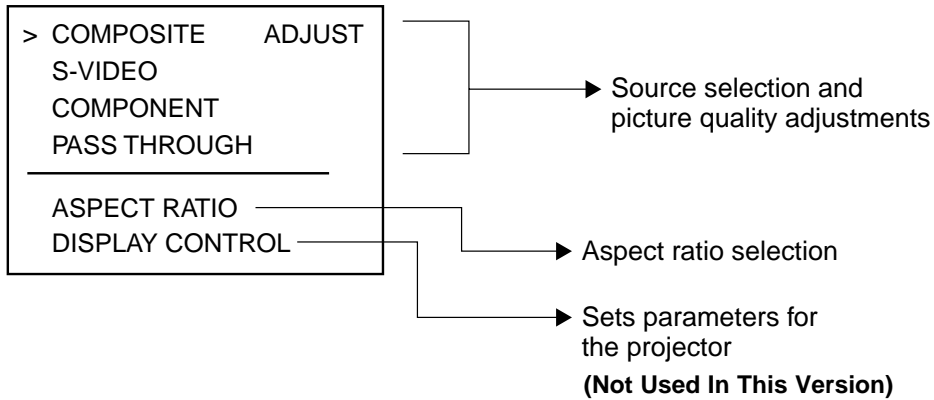

The main menu (shown above) includes two sections: Source Selection/ Picture quality adjustments and Functional adjustments. Pressing MENU on the front panel or on the remote control will bring up the main menu.

In the menu shown above, Composite video is selected as the current source. This is indicated by an arrow to the left of 'COMPOSITE' in the menu. If S-video were selected, for example, the arrow would then be to the left of 'S-video'.

**To select a source**, there are two options. First, using the main menu, you can highlight the desired source with the up or down arrows (front panel or remote), then press enter. The VHD-4402 ULTRA will immediately switch to the desired source. The second option is to simply press the LEFT or RIGHT buttons on the remote or front panel (see page 4) while there are no menus on screen.

**Note:**

There will be no on-screen display when the PASS-THROUGH is used. If you are using the PASS-THROUGH and wish to change sources, simply press the left or right buttons on the remote or front panel.



## MENU DESCRIPTION AND NAVIGATION

---

**Aspect Ratio** allows selection of one of the three aspect ratios provided by the processor. You have two options for selecting an aspect ratio: First, highlight ASPECT RATIO on the main menu, then press ENTER. Then select the desired aspect ratio, and again press ENTER. The second option is to simply press the UP or DOWN arrows on the remote or front panel. Doing this will toggle you through the three choices- Anamorphic (16:9), Letterbox and Standard (4:3). For more information on aspect ratios, please refer to pg. 18.

**Display Control:** Not used in this version.

### Picture Quality Adjustments

#### MAIN MENU

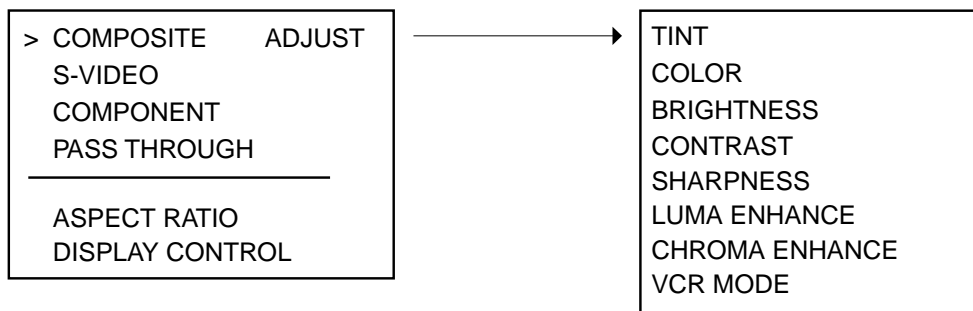

Picture quality adjustments are those that change the various parameters of the image, such as COLOR (saturation level) and BRIGHTNESS (black level), among others. Typically, these adjustments should be made only once (during initial calibration) and then left alone. However, if it is necessary to make any adjustments, perform the following procedure:

In the example above, note that COMPOSITE is the active source. This is indicated by an arrow to the left of the word 'COMPOSITE'. To make adjustments, highlight the active source (composite in this case) and press ENTER.

**Note:**

Pressing ENTER after highlighting a different source will switch you to that source instead of making picture quality adjustments.

After pressing ENTER, the picture quality menu will appear (the menu to the right of the main menu above). To adjust a certain function, highlight it with the or DOWN buttons, and press ENTER. The following will then appear on-screen (we'll use COLOR as an example):

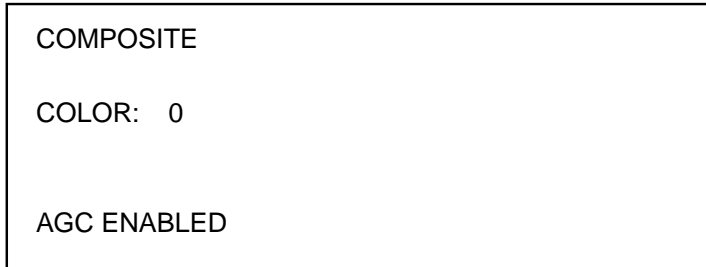

To Change the value of the function (Color in this case), simply press the UP button to increase the value, and the DOWN button to decrease the value. For COLOR and CONTRAST, to turn AGC on or off, press the ENTER button.

- **TINT**

Also known as 'HUE'. Decreasing this will give the picture a 'redder' tint, increasing it gives the picture a 'greener' feel. This is actually a ratio of one color vs. another (red, green or blue), so making the picture 'greener' for example, is actually affecting all three colors. It is recommended that this function stay about mid-range.

- **COLOR**

Also known as 'SATURATION'. Decreasing this will decrease the amount of color in the image (it will be black and white if it is decreased all the way), Increasing this will add color to the image. This is typically best at about mid-range, but increasing it a little will add more vibrance to the colors. However, if it is increased too high, the picture will look very unnatural.

The 'AGC enabled/disabled' function should normally be left in 'AGC Disabled'. If, however, you are using an unstable source and are having color level fluctuations in the image, you may try to use 'AGC Enabled' to see if it helps.

- **BRIGHTNESS**

This actually controls the black level of the picture- not the overall light output! If this is set too low, then there will be no detail in the dark areas of the image. If it is set too high, then the picture will appear 'washed out'. This is normally set using a 'PLUGE' test pattern; if this has already been calibrated it should not be adjusted (for best results).

- **CONTRAST**

This is the ratio of brightest whites to the darkest scenes. Basically, this increases the 'white level' of the image. While it will increase the light output to a certain extent it could also cause 'clipping' if it is increased too high. This appears as a loss of definition in the brightest scenes, where the whites appear to 'bleed together'.

The 'AGC enabled/disabled' function should normally be left in 'AGC Disabled'. If, however, you are using an unstable source and are having brightness (light output) level fluctuations in the image, you may try to use 'AGC Enabled' to see if it helps.

## MENU DESCRIPTION AND NAVIGATION

---

### • SHARPNESS

This controls the 'high-frequency' detail of the image. The more sharpness is increased, the more detail is added into the picture. However, if it is increased too much, it will also increase 'noise' in the picture as well as other types of artifacts. This may be set to personal preference; midrange is factory-preset.

### • LUMA ENHANCE

This is similar to the sharpness control, but it does not boost the frequencies all over the picture. Instead, this is more like an 'edge enhancement' that makes transitions between objects more or less defined. The edges of a building, for example, may appear more or less defined depending on the setting of LUMA ENHANCE. This affects areas of the image that do not have much color.

The LOW and HIGH FREQUENCIES setting on the bottom of the LUMA ENHANCE adjustment window are for different sources; it should be set to LOW FREQUENCIES if a lower quality source is used (VCRs), and HIGH FREQUENCIES if a good quality source like a DVD player is used. To select HIGH or LOW FREQUENCIES, use the ENTER button.

### • CHROMA ENHANCE

This is basically the same as LUMA ENHANCE, but affects the color edges. It helps remove the watercolor look of NTSC images. Use low frequency for VCRs and cable and high frequency for DVDs.

# ASPECT RATIOS

---

## First, the Basics

An 'aspect ratio' is simply the ratio of the width vs. the height of the screen. For example, the current aspect ratio standard is 4:3 (or 1.33:1), where the image is 4 units wide and 3 units tall.

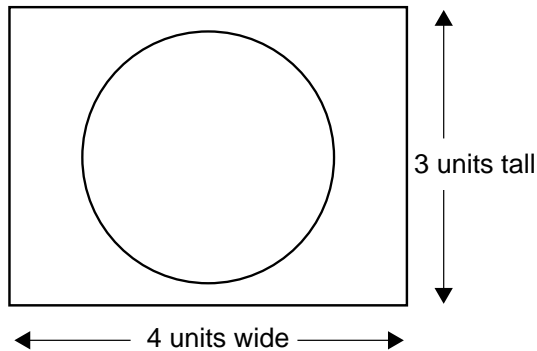

All of our 'regular' televisions are this aspect ratio. You have probably noticed that occasionally you'll watch a movie that does not fill the screen vertically. This is because the movie was filmed in WIDESCREEN (letterbox), and the result is 'black bars' above and below the image:

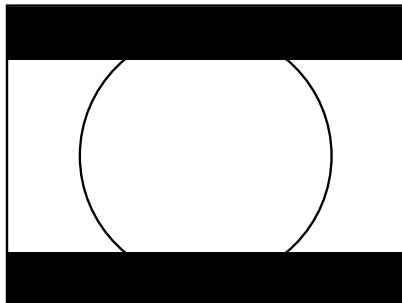

Obviously, watching a movie like this does not lend itself to a truly cinematic experience! This is why Runco invented the first-ever multiple aspect-ratio projection system back in 1991, so true movie-lovers can watch actual widescreen (letterbox) movies on a WIDESCREEN!

A WIDESCREEN can be a number of aspect ratios; many movies are either 1.85:1 or 2.35:1, and HDTV is always 1.78:1 (16:9). The way we create a widescreen (or LETTERBOX) aspect ratio is to take a full 4:3 image, then 'blank' (or cut off) the top and bottom so the displayed image is in a widescreen format. For movies recorded in 'letterbox', there would be no information above and below the screen anyways, so we're not losing any of the picture. However, if you were to watch standard television broadcast this way, you would lose some information (see next drawing).

## ASPECT RATIOS

---

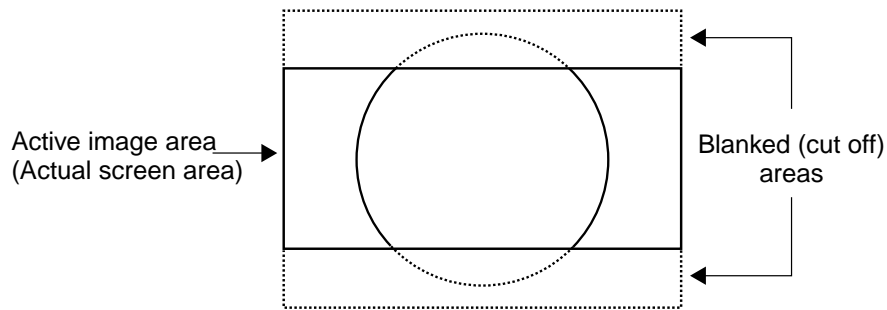

As you can see, our screen in this example is a 1.85:1 ratio. The dashed lines show the area that we 'blanked'. If you recall, watching a letterbox movie on a 4:3 screen gave us black bars; therefore with letterbox movies, we're not losing any information!

The 'other' type of widescreen is called 'ANAMORPHIC'. The image is still a widescreen format, but instead of 'blanking' the top and bottom, we simply reduce the overall height of the image:

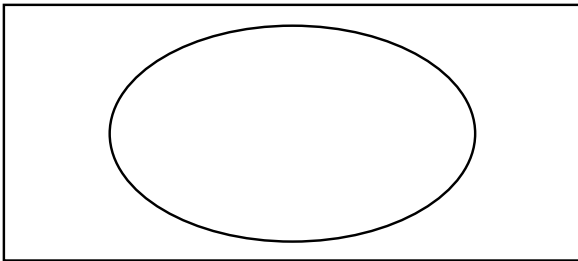

As a result, all objects will be 'short and fat' (like the circle above), right? Well, not if you're using software that is anamorphic. Most (but not all) DVD movies have an anamorphic option.

Anamorphic material will always produce a better image when using a high quality scaler such as the VHD-4402 ULTRA. The reason is that you will actually get more lines of resolution (and ultimately more detail) when using anamorphic titles (assuming your display device has that capability). Basically, a TV image is made of 480 lines. When using LETTERBOX (the drawing at the top of the page), we're 'throwing away' information by blanking the top and bottom. The end result is that there will only be around 360 lines of information on the screen. With anamorphic, 480.

# DIMENSIONS

## Front Panel

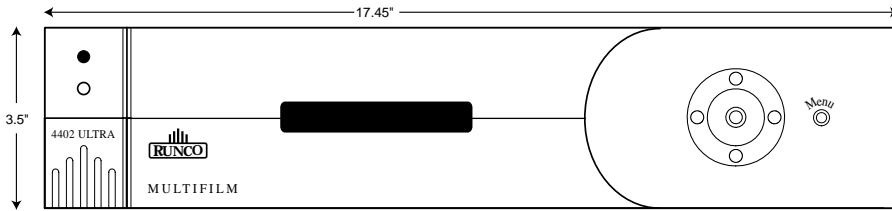

## Rear Panel

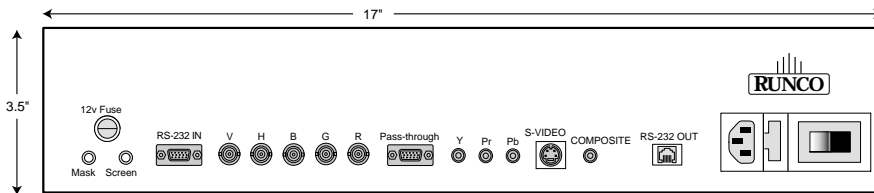

## Top

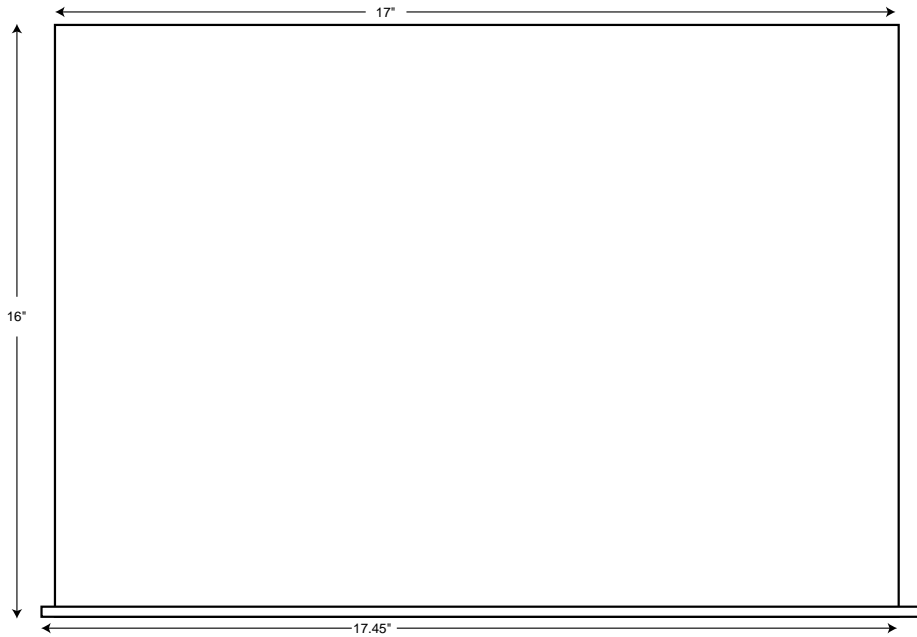

## Side

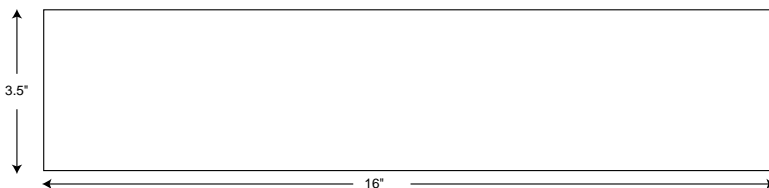

# RS-232 PROTOCOL

---

9600 Baud  
8 bits  
No parity  
1 Stop bit

## ASCII

RxD of the PC or TxD of the VHD is on pin2  
TxD of the PC or RxD of the VHD is on pin3  
Gnd is pin 5  
RTS of the PC or CTS of the VHD is on pin7 (not used)  
CTS of the PC or RTS of the VHD in on pin8 (not used)

Command format <input><aspect ratio>

### Inputs:

0 = Composite  
1 = S-Video  
2 = Component  
3 = Pass Through

### Aspect Ratios:

A = Anamorphic  
L = LetterBox  
S = Standard (4:3)  
H = HDTV (for pass through)  
C = Computer (for pass through)

### Power:

ON = Power on  
OF = Power off

To keep the currently selected aspect ratio or input, replace the letter/number with a dash "-"

Each command must be followed by a carriage return <CR>.

### Examples:

2L will select the component input and change the aspect ratio to letterbox  
-A will change the aspect ratio to anamorphic, but leave the input selection alone  
1- will change the input to S-Video, but leave the aspect ratio alone

RS-232 Projector Control requires a cable terminated with male RJ-11 jacks at both ends.  
Wiring is the same as for a phone (ie. in a cross configuration).

### Projector

### VHD-4402 ULTRA

N.C.	1	_____	6	
GND	2	_____	5	GND
RxD/TxD	3	_____	4	RxD/TxD
RxD/TxD	4	_____	3	RxD/TxD
GND	5	_____	2	GND
N.C.	6	_____	1	

# SPECIFICATIONS

---

**Inputs:** (1) Component, (1) S-video, (1) Composite, (1) Pass-through

**Input standards:** NTSC (PAL, NTSC export version)

**Output formats:** 540p, 600p (38 khz)

**Bandwidth:** Video inputs: 5.5 Mhz  
Pass-through: 100 Mhz

**Power input:** 120V (220V export model), 50/60 Hz

**Power consumption:** 15W

**Control Options:** RS-232, Infrared, Front panel

**Operating environment:** 41-95° F (5-35° C)  
0-90% humidity (non-condensing)

**Dimensions:** Width: 17.45 in./443.23 mm  
Depth: 16 in./406.40 mm  
Height: 3.5 in./88.90 mm

**Weight:** 16 lbs./7.26 kg

## **Safety**

**Regulations:** Complies with UL, FCC class 'B', CE, C-tick

**Fuses:** (Screen Fuse: 5mm x 25mm, AGC, 1A, 250v, Fast Blow)  
(Main Fuse: 5mm x 20 mm, 500mA, 250v, Slow Blow)

**Rack Ears:** Included

## **Supplied Accessories**

- Remote Control w/ 2 AAA Batteries
- Power Cord
- User's Manual





RUMA-008900 rev 10-00



**THE WORLD'S FINEST HOME THEATER PRODUCTS™**

2463 Tripaldi Way  
Hayward, CA 94545  
510-293-9154 Fax: 510-293-0201