

Palsonic

INSTRUCTION MANUAL

MICRO COMPONENT SYSTEM

PMC-191



**PALSONIC CORPORATION PTY LTD
1 JOYNTON AVENUE
WATERLOO NSW 2017 AUSTRALIA
TEL: (02) 9313 7111
FAX: (02) 9313 7555
www.palsonic.com.au**

**PALSONIC CUSTOMER SERVICE
TELEPHONE
AUSTRALIA: 1300 657 888**

LOCATION OF CONTROLS

- 1.) CASSETTE
- 2.) REWIND KEY
- 3.) PLAY KEY
- 4.) RECORD KEY
- 5.) CD DOOR
- 6.) REMOTE SENSOR
- 7.) FUNCTION SELECTOR
- 8.) MULTI FUNCTION DISPLAY
- 9.) FM MODE / BEAT CUT SELECTOR
- 10.) STANDBY / ON INDICATOR
- 11.) POWER BUTTON
- 12.) SKIP / TUNING DOWN BUTTON
- 13.) PLAY/PAUSE
- 14.) POWER (STANDBY) BUTTON
- 15.) STOP BUTTON
- 16.) BAND SELECTOR
- 17.) HEADPHONE SOCKET
- 18.) SKIP / TUNING UP BUTTON
- 19.) EXTRA BASS
- 20.) VOLUME UP/DOWN BUTTON
- 21.) FAST FORWARD KEY
- 22.) STOP / EJECT KEY
- 23.) PAUSE KEY
- 24.) AC POWER CORD
- 25.) FM ANTENNA LEAD
- 26.) SPEAKER JACKS (L / R)

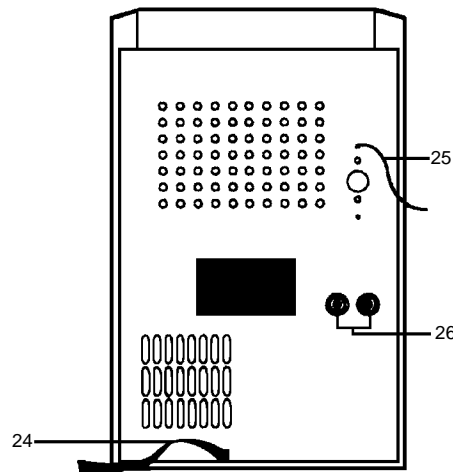
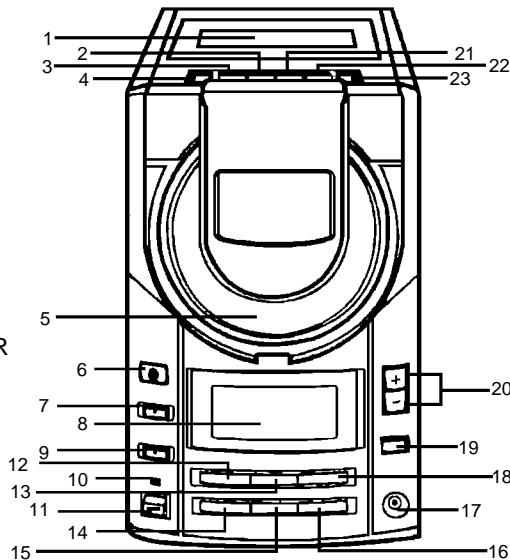

CAUTION:

USAGE OF CONTROLS OR ADJUSTMENTS OR PERFORMANCE OF PROCEDURES OTHER THAN THOSE SPECIFIED HEREIN MAY RESULT IN HAZARDOUS RADIATION EXPOSURE. THIS UNIT SHOULD NOT BE ADJUSTED OR REPAIRED BY ANYONE EXCEPT QUALIFIED SERVICE PERSONNEL.

IMPORTANT:

SINCE MOVEMENT OF THE CD MECHANISM AND THE SENSITIVE CIRCUITRY MAY CAUSE INTERFERENCE, TO THE RADIO TURNER NEARBY, SWITCH THIS UNIT OFF WHILE OPERATING OTHER RADIO DEVICES.

LISTENING TO RADIO

Manual Tuning

1. Set Function Selector to "Tuner" position.
2. Set Band button to the desired band.
3. Press Manual Tuning "UP" button or Manual Tuning "DOWN" button until your desired station is reached.
4. Adjust the volume control to the appropriate level as desired.

Auto Tuning

1. Follow steps 1, 2 of "Manual Tuning".
2. Press UP or DOWN button continuously to start the automatic tuning.
3. To terminate Auto Tuning, press the UP or DOWN button again.

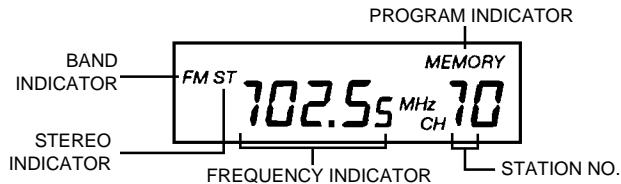

Preset Stations by Remote Handset

This unit equipped 10 preset station for FM and MW, 5 station for LW if LW is available. Once they are preset broadcasting corresponded to those can readily be enjoyed by simply pressing the Preset Station button.

1. Set in Tuner mode.
2. Your desired station can be received by "Manual Tuning" or "Auto Tuning".
3. Press the MEMORY button (at Remote), to enable program state.
4. Press the M-UP / REPEAT button (at Remote), to adjust preset station number.
5. Frequency is written in the Preset a Memory by pushing MEMORY button once again.
6. Repeat step 2 to step 5 to enter additional channels into Program.
7. To return normal Tuner mode, leave keys free.

- **Remarks:** There are 5 seconds for program state. After 5 seconds this state would release automatically.

Calling the Preset Stations

Press the M-UP / Repeat Key (at Remote) to select the Preset Station in order.

FM & FM-Stereo Reception

- Set FM mode selector at "MONO" position. Programs are received in Mono mode. In particular when stereo signals are weak, it is preferable to receive the program in MONO.
- Set FM mode selector at "STEREO" position for receiving stereo programs.

Beat Cut

When beats are produced while listening to recording an AM broadcast, active the beat cut switch so the beats are eliminated or minimised.

PLAYING COMPACT DISC

Getting Started

1. Set Function Selector to CD mode. lift up the CD door and put a disc into the Compact Disc Compartment, then close the Compartment.
2. The Display will show "00" for a few seconds, then the total number of tracks and the total playing time of the disc.
3. "DISC" will be displayed when there is no disc inside the compartment.

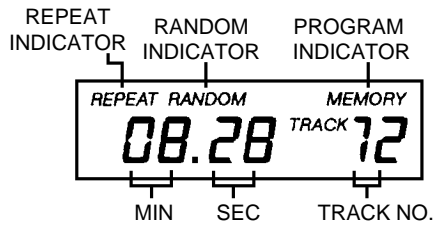

General Operation

PLAY / PAUSE Button

Press once to start play, press once again to stop the ►|| disc play temporarily. When CD player is paused, display is blinking.

STOP Button

Press to stop play.

SKIP Buttons

Press once to skip to next track ►► or back to previous track ◀◀ UP/ ►► and DOWN / ◀◀

RANDOM Button (at Remote)

Press once, the display will show a "Random".

Press the Play button to play the disc in random order. When CD is playing in Random mode, press UP / ►► to select another track randomly.

Press the Random button again to terminate the Random display.

- During CD Play Random Play is started by pressing the RANDOM button once.
- To obtain optimum sound performance for CD, select the switch at the back to CD position.

Program Play (For CD only) by Remote

Up to 20 tracks can be programmed for disc play in any order. Before use, be sure to press the Stop button.

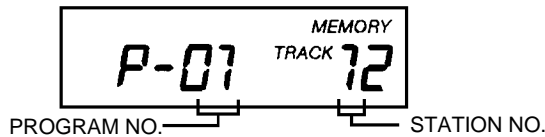

1. Set in CD mode.
2. Press the MEMORY button (at remote), the display will show blinking "Track" and "Memory". Moreover, it will indicate program no. and digits for track no. to be programmed.
3. Select a desired track by using the Skip buttons.
4. Press the MEMORY button again to enter the track into the program.
5. Repeat steps 2 and 3 to enter additional memories into the program, if necessary.
6. When all the desired tracks have programmed, press PLAY / PAUSE button to play the disc in the order you have programmed. The display will show the Program Indicator "MEMORY" to identify this function.
7. Press STOP button to terminate program play.

- **Remarks:** There are 5 seconds for memory writing enable state, after that the state would released automatically.

Notes:

1. The program memory will be cleared when the Power button is set to "OFF", when CD mode is changed to other modes, or when EJECT button is pressed.
2. During program play, press UP / ►► button to select the programmed track in order.

You can repeat all programmed tracks endlessly by this function.

1. Follow step 1 to step 5 in Program Play.
2. Press M-UP / REPEAT button.
3. To cancel Repeat Play, press the M-UP / REPEAT button again.

Repeat Play (For CD only) by Remote

Single Track Repeat Play (*only available for normal playing*)

You can repeat a particular track of the disc endlessly by this function.

1. Select a desired track by Skip buttons.
2. Press M-UP / REPEAT button twice at Remote.
3. The display will show "REPEAT" and flashing, and repeat function would be initialised.
4. Press PLAY / PAUSE Button to start.
5. To cancel repeat play, press the M-UP / REPEAT button one again.

- **Remarks:** *To repeat the track that is playing, press the M-UP /REPEAT button twice.
All Tracks Repeat Play (available for both normal playing and programmed playing)*

You can repeat the entire disc endlessly by this function.

1. Press M-UP / REPEAT button once.
2. The display will show "REPEAT".
3. Press PLAY / PAUSE button to start.
4. To cancel repeat play, press the M-UP / REPEAT button twice.

Playing the Beginning of each Track (INTRO)

The Intro feature lets you sample all of the CD tracks for 10 seconds.

1. Press INTRO. Intro play will begin with Track 1.
2. To cancel Intro play and begin normal play, press INTRO again.

LISTENING TO TAPE

General Operation

| | |
|------------------|---|
| Stop / Eject key | Press to stop all deck operations. Press again to the Cassette Doors. |
| Fast Forward Key | Press to start rapid tape winding in either forward or reverse direction. |
| Fast Rewind Key | Press Stop / Eject Keys when the cassette spools stop turning. |
| Play Key | Press to start playing a tape. |
| Pause Key | Press to stop tape operation temporarily. Press again to resume tape operation. |
| Record Key | Press together with Play Key to start recording. |

Playback

- Set the Function selector to TAPE position.
- Put in your cassette tape.
- Press Play Key to activate playback.
- Adjust the Volume Control to the desired level.
- Use Pause Key when you want to stop playback temporarily.
- Press Stop / Eject Key when finished.

RECORDING

A. Recording From Radio

- Set in Tuner mode.
- Tune in your station and put in your cassette tape.
- Press Record Key and the Play Key of deck at the same time to start recording.
- Press STOP / EJECT Key when finished.

NOTE: If beat noise is present when recording. Adjust the position of the Beat Cut switch on mode selector (For AM / MW or LW Band only).

B. Recording From CD

- Set Function selector to "CD" position.
- Insert a cassette suitable for recording, press pause key then press record key. Recording function will be on stand by.
- Activate the CD player, and then press (to release) pause key to start recording.
- To stop recording, first press STOP button on CD player - then press the STOP / EJECT key on tape deck.

REMOTE CONTROL TRANSMITTER CONTROL FUNCTIONS

- 1.) POWER
- 2.) DIRECT SEARCH KEYS
- 3.) VOLUME UP / DOWN
- 4.) SKIP DOWN BUTTON
- 5.) SKIP UP BUTTON
- 6.) MODE BUTTON
- 7.) RANDOM BUTTON
- 8.) SCAN-UP BUTTON
- 9.) BAND SELECTOR
- 10.) MEMORY BUTTON
- 11.) M-UP / REP BUTTON
- 12.) INTRO BUTTON
- 13.) PLAY / PAUSE BUTTON
- 14.) STOP BUTTON
- 15.) MUTE

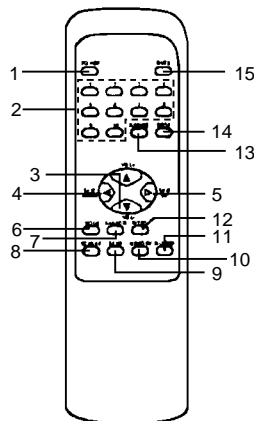

BATTERY INSTALLATION

THE INFRARED TRANSMITTER REQUIRES 3.0 VOLTS FOR OPERATION. (UM-4/AAA SIZE)

Button Description

- PLAY/PAUSE - IN CD MODE, PRESS ONCE TO START PLAYBACK. PRESS ONCE AGAIN TO STOP THE DISC PLAY. TEMPORARILY.
- STOP - PRESS TO TERMINATE CD PLAYBACK.
- SKIP ◀◀ - PRESS ONCE TO SKIP TO PREVIOUS TRACK.
- SKIP ▶▶ - PRESS ONCE TO SKIP TO NEXT TRACK.
- REPEAT - IN CD MODE, PRESS TO ENABLE REPEAT PLAY.
- MEMORY - IN CD / RADIO MODE, PRESS TO ENTER PROGRAM MODE.
- RANDOM - IN CD MODE, PRESS TO ENTER RANDOM MODE.

SPECIFICATIONS

GENERAL

Power Supply: 240V/50Hz
Power Consumption: 30 Watt
Output Power (RMS): 2 x 5W
Terminal Impedance: Speaker 4.0 OHMS, Phones 32 OHMS
Unit Dimensions: 188(L) x 230(W) x 279(H) mm
Unit Weight: 7 kgs

CASSETTE SECTION

Tape Speed: 4.75 cm/sec
Recording System: AC BIAS
Erasing System: DC MAGNET
Frequency Response: 125-6300Hz

CD SECTION

Channel: 2 Channels
S/N Ratio: 60dB
Sampling Frequency: 44.1kHz
Disc Size: 75 or 120 mm
Frequency Response: 125Hz - 20kHz

RADIO SECTION

Tuning Frequency: AM: 511 - 1620KHz
FM: 87.5 - 108MHz

PALSONIC CORPORATION PTY LTD
1 JOYNTON AVENUE
WATERLOO NSW 2017 AUSTRALIA
TEL: (02) 9313 7111
FAX: (02) 9313 7555
www.palsonic.com.au

**PALSONIC CUSTOMER SERVICE
TELEPHONE
AUSTRALIA: 1300 657 888**