

SI-275

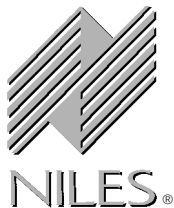

Systems Integration Amplifier™



CONGRATULATIONS!

Thank you for purchasing the Niles SI-275, one of the most flexible and convenient amplifiers ever offered. Like all Niles products, the SI-275 is built to the highest standards of quality control and reliability. With proper installation and operation, you'll enjoy years of trouble-free use.

Niles manufactures the industry's most complete line of custom installation components and accessories for audio/video systems. For a free full line catalog write:
Niles, Catalog Request, P.O. Box 160818, Miami, Florida 33116-0818

TABLE OF CONTENTS

| | |
|------------------------------|----|
| INTRODUCTION | 2 |
| FEATURES AND BENEFITS | 3 |
| INSTALLATION CONSIDERATIONS | 5 |
| INSTALLATION | 11 |
| FRONT AND REAR PANEL DETAILS | 9 |
| OPERATION | 15 |
| TROUBLESHOOTING GUIDE | 16 |
| SPECIFICATIONS | 18 |

INTRODUCTION

The SI-275 is a member of the award-winning Niles Systems Integration Amplifier family. It is designed for home theaters and whole house audio systems requiring high power. Niles specifically created Systems Integration Amplifiers to solve the problems of interfacing with different brands and models of equipment, different acoustic environments in different rooms, and different kinds of applications; home theater, stereo, and background music. The SI-275 brings extremely high-current power to a custom installed A/V System in a remarkably convenient way.



SI-275
*Systems Integration
Stereo Power Amplifier*

FEATURES AND BENEFITS

Real World Power

The SI-275 delivers 75 watts per channel at 8 Ohms and 100 watts per channel at 4 Ohms. You'll get tremendous bass and dynamics from every pair of speakers powered by an SI-275.

Transparent Sound

The audio circuitry of the SI-275 is constructed using the finest parts available; including 1% metal film resistors, high quality capacitors, and oversized heat sinks. All this attention to technical detail creates a sound that is clear and uncolored with phenomenal imaging.

Freedom From Crosstalk

Each channel of the SI-275 is powered via its own independent power supply. This increases the isolation between the two channels, and eliminates cross talk guaranteeing you absolute silence as the backdrop to your music.

Current For Reactive Loads

The high current design of the SI-275 assures that even unusual and reactive loads are handled with aplomb. A massive toroidal transformer with two separate windings for each of the power supplies supplies more than ample current to your system.

Freedom from Fan Noise

The oversized heat sinks inside the SI-275 allow the amplifier to stay cool even when operating into low impedance loads—without the noise of fan-cooled amplifiers.

Independent Level Controls

Each channel has its own independent level control enabling you to precisely match the SI-275 to the rest of your system. The level controls also enable you to limit the volume, preventing abuse of the system.

Lifetime Connections

The SI-275 features gold plated stereo inputs, the cascade stereo outputs as well as the five way binding posts are gold plated to ensure perfect connections without corrosion for years to come.

Turn-On Modes

The SI-275 features three turn-on modes: 1. Music Sense 2. External Voltage Trigger 3. Manual Turn-On via the front panel switch. You can configure the SI-275 to interface with any kind of system and have the unit automatically turn on.

Automatic Protection

The SI-275 is equipped with sophisticated protection circuits. In the unlikely event that a problem occurs, the amplifier shuts itself off. When conditions return to normal, regular operation resumes.

Status Display for Troubleshooting

LED's on the front panel indicate Power, Active Status, and a Protection Warning. With a glance at the front panel, a troubleshooter is quickly provided with key information!

Control Output

A 12 volt DC output is provided whenever the amplifier is on, allowing you to operate voltage-triggered devices like motorized screens and curtains.

Designed and Engineered in the USA

Limited two year parts and labor Warranty.

INSTALLATION CONSIDERATIONS

Placement

Place the SI-275 on a flat level surface like a table or shelf. It should be placed upright so that its weight rests on the four attached feet. Placing the weight of the amplifier on the rear or front panel for even an instant will result in damage to the amplifier's connectors and controls.

The SI-275, like any hi-fi component, will last much longer if it is given adequate ventilation for proper cooling. When installing the SI-275 in a cabinet, be sure that the rear of the cabinet is open to fresh air to provide proper cooling (see **Figure 1**). If the cabinet's design will not accommodate an open rear, install two small "boxer fans" to provide continuous air flow into and out of the cabinet (see **Figure 2**). Place the SI-275 so that there is at least 5" of free air space above the chassis. If the amplifier is located on a carpeted surface, place a board under the amplifier's feet. Do not block the ventilation holes on the top and bottom of the SI-275.

The SI-275 is equipped with an internal transformer, which generates a powerful magnetic field which could induce hum in a turntable (particularly a turntable equipped with a moving coil cartridge). Do not place a turntable directly above or directly adjacent to the SI-275.

Figure 1

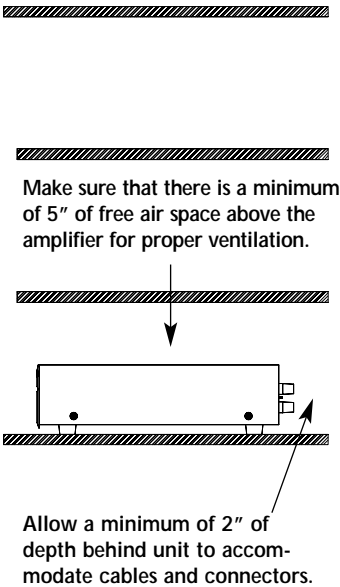
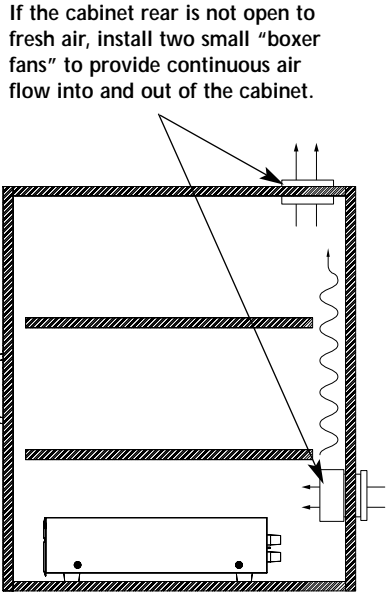
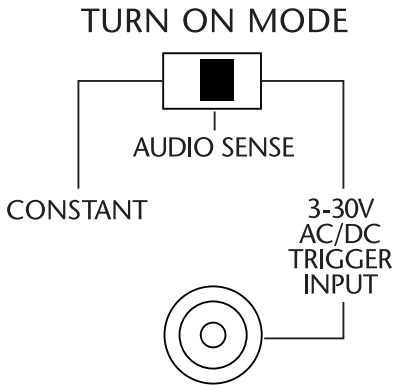

Figure 2



Turn-On Modes

The SI-275 draws more current than a preamplifier's switched AC outlet can safely supply. Also, your preamplifier may "thump" at dangerous volumes if the amplifier is already on when the preamp turns on. It is usually best to turn the amplifier on only when it is needed. The Turn-On Mode selector switch gives you three options for turning the SI-275 on and off.



Constant - The auto turn-on circuitry is off. The front panel master power switch operates the amplifier. In is "On", out is "Off".

Audio Sense - The master switch on the front panel must be in the "On" position. The amplifier is off when there is no audio signal present at either the left or the right input, but the sensing circuitry is on. The turn-on sensing circuitry looks for a tiny amount of audio signal present at any of the audio inputs. If it detects a signal, the amplifier is turned on. Once the audio signal stops, the sensing circuit waits two minutes, then turns the amplifier off.

3-30 Volt AC/DC Opto-Isolated Voltage Trigger - The master switch on the front panel must be in the "On" position. The amplifier is off when there is no 3-30V AC or DC voltage detected at the trigger input. Once the sensing circuitry detects a voltage, the amplifier is turned on. Once the voltage stops, the sensing circuit instantly turns the amplifier off. Voltage triggers can be supplied by Niles automated switchers, some video projectors, some surround sound processors, or something as simple as a 16 volt AC wall adapter (Niles XF00008) plugged into the switched outlet of your stereo receiver. **DO NOT USE A DC WALL ADAPTER.** The long discharge time of the DC adapter's filter capacitor will delay the turn-off of the amplifier.

If you are using a wall adapter or external power supply to provide the trigger, it doesn't have to be very large (a minimum current capability of 2.5 milliamps for a 3 volt trigger increasing up to a minimum of 38 milliamps for a 30 volt trigger).

Multiple Speaker Loads

The SI-275 is stable into very low impedance loads. This means you can safely operate three pairs of 8 ohm speakers (a 2.67 ohm load) directly connected to the SI-275. Note that the SI-275 does not have on/off speaker switching built in. When the amplifier is on, so are all of the speakers.

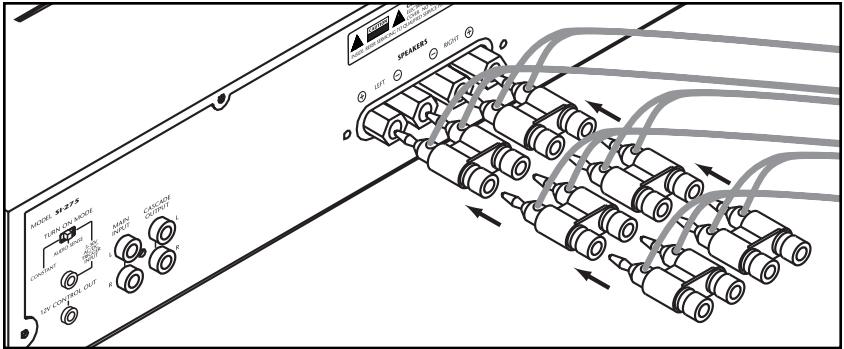

Niles makes a number of different speaker selection and impedance matching systems. Speaker selection systems allow each pair of speakers to be turned on and off from your equipment location (or even via remote control). That way, you know that the speakers in the bedroom are off so you can avoid waking a sleeping spouse! These speaker selectors provide an easy way to terminate all of the wires for more than three pairs. Testing and troubleshooting a new system is much easier with the individual room labels and on/off switches of a Niles speaker selection system. Additionally, Niles speaker selection systems offer impedance matching features which will allow you to connect up to ten pairs of speakers to your SI-275 amplifier.

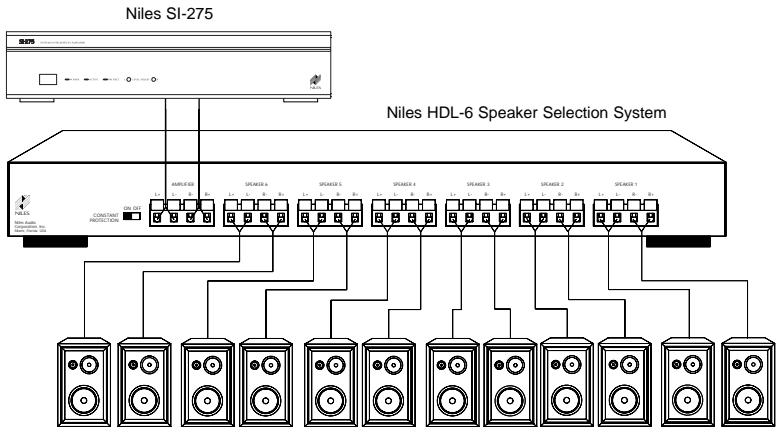

Speaker selection systems allow each pair of speakers to be turned on and off from your equipment location (or even via remote control).

Cable and Wire

It will be easier to reconfigure or troubleshoot your system in the future if you label the cables and wires for their destination or source, rather than which terminal of the SI-275 they are connected to.

The SI-275 connects to your sources via shielded line level audio cables with RCA phono plugs. Use high quality cables with your Niles amplifier for the lowest possible noise and best overall performance. Your Niles dealer can recommend the proper cable.

The SI-275 connects to your speakers using 2 conductor speaker wire. For most applications, we recommend you use 16 or 18 gauge wire. For wiring runs longer than 80 feet, we recommend 14 gauge wire. The binding posts of the SI-275 will accommodate up to 12 gauge wire. Larger sizes can be accommodated by attaching banana plugs to the wire. Note that the binding posts accept dual banana or single banana connectors.

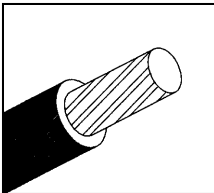

TECH TIP

Wire size is expressed by its AWG (American Wire Gauge) number. The lower the number, the larger the wire, i.e. twelve AWG is physically larger than fourteen AWG.

Red "Power" LED confirms the amplifier is connected to a live AC power outlet. (and that the master power switch is on).

Red "Active" LED lights when the amplifier circuitry has been turned on by the Turn-On circuits.

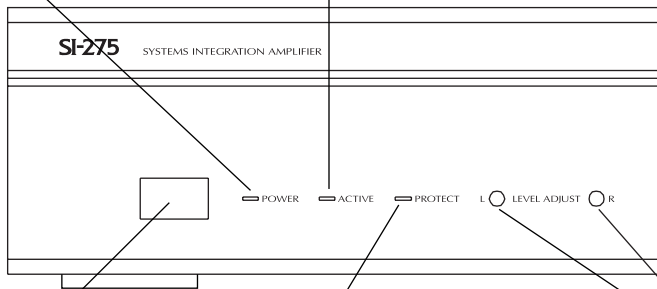

Front panel "Master Power" switch turns off the entire amplifier, including the Turn-On circuitry.

The red "Protect" LED indicates the amp has shut down because there is a fault in the speaker, the wiring, or with the SI-275 itself.

Main Inputs enable you to route a stereo line level source to the SI-275.

Cascade Outputs of the main input enable you to daisy chain multiple amplifiers.

"Turn-On Mode" switch

3.5 Mini Plug socket for voltage input.

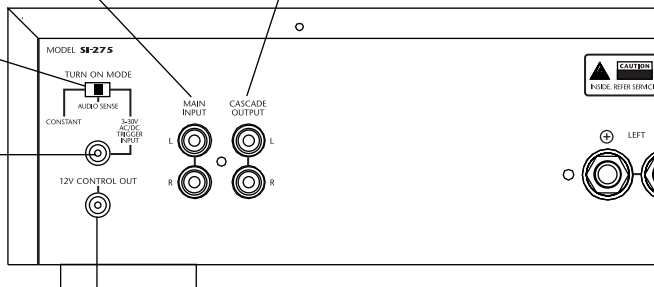

3.5mm Mini Plug socket for 12v DC Control output.

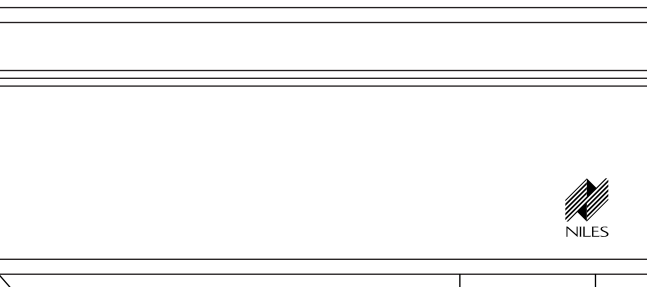

Level Adjustment screws enable you to preset the maximum system volume (or match levels with another amplifier).

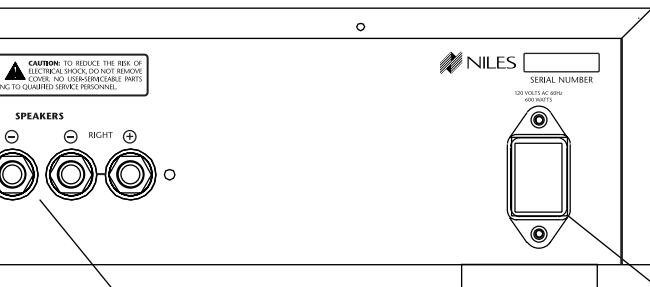

Binding posts for speaker connections.

IEC receptacle for AC power cord.

INSTALLATION

- 9 Setting The Turn-On Mode Switch
- 9 Control Output
- 10 Speaker Wire Connections
- 13 Line Level Audio Inputs
- 13 Cascade Audio Outputs
- 14 AC Power plug
- 17 Rail Fuse Holders

Setting the Turn-On Mode Switch

The SI-275 has three turn-on modes. Select which mode you desire by sliding the mode switch. See Installation Considerations on page 6 for more information about each of the turn-on modes.

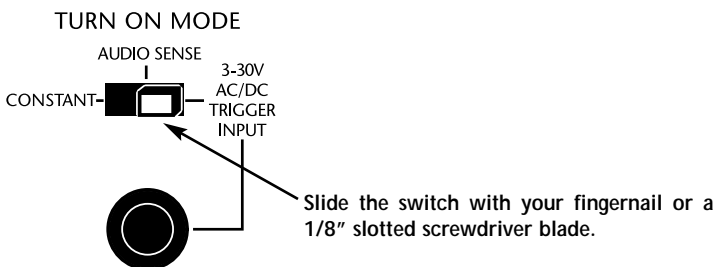

Control Output

This terminal provides a 12v DC signal suitable for triggering Niles automated switchers, some motorized screens, some electric curtain controls, etc. The trigger voltage is present only when the amplifier is active or "on". When the amplifier turns "off", the 12 volt signal is off.

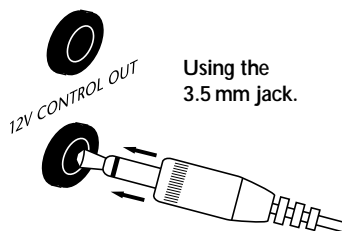

| STEP | DESCRIPTION |
|--|--|
| 1. Check the requirements of the device you want to control. | The control output has a maximum current capability of 12vDC 150 mA. |
| 2. Connect the 3.5 mm Jack to the control output maintaining proper polarity (tip = +) | Niles makes an accessory cable plug FG00724. |

Speaker Wire Connections

CAUTION! All speaker wire connections must be made with the amplifier Off.

Bare Wire

Unscrew the red or black plastic knob, insert the bare wire end into the opening, and then tighten the knob until the wire is securely clamped.

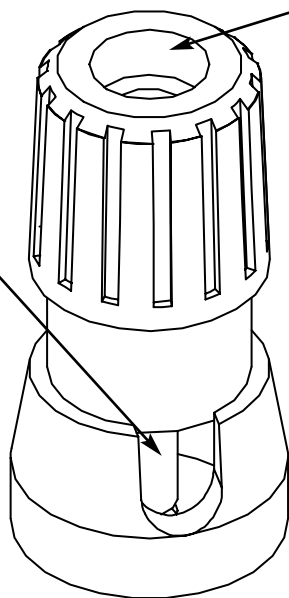

Banana Plugs

There are many types of banana plugs, some crimp, some solder. The Niles gold banana plug has a quick-connect binding post for the bare wire on the body of the plug. A banana plug is simply inserted into the jack at the end of the amplifier's binding post. Dual banana plugs will fit the SI-275 binding posts.

STEP

DESCRIPTION

1. Label all wires.

If you label the wires for their destination, rather than which terminal of the SI-275 they are connected to, it will be easier to reconfigure your system in the future.

2. Connect one stripped wire end or banana plug to the black terminal and one to the red terminal.

A. Split the speaker wire insulation so that at least two inches of each conductor are separated.

B. Strip one half inch of insulation from the end of each conductor of the speaker wire

C. Attach banana plugs or twist the strands of wire together and insert them into the appropriate binding post.

CAUTION- Avoid even a single strand of wire touching the chassis or another connector.

Line Level Audio Input

CAUTION! THE AMPLIFIER MUST BE OFF WHENEVER YOU MAKE CHANGES TO THE INPUT CONNECTIONS.

| STEP | DESCRIPTION |
|---|---|
| <p>1. Label all of the interconnecting cables for the sources they connect to.</p> | <p>Use audio patch cables with RCA phono plugs attached to the ends.</p> |
| <p>2. Connect the sources by inserting the RCA plugs into the amplifier's jacks.</p> | <p>Connect outputs from your sources to inputs on the amplifier. Never connect a source or preamplifier's input (e.g., record inputs) to the inputs of your SI-275.</p> |

Cascade Audio Outputs

The "Cascade Audio Outputs" enable you to connect another amplifier to your preamplifier output. The connectors are gold-plated RCA phono jacks. Connect them to another amplifier's inputs with a standard audio patch cable. The outputs are not buffered; if you wish to daisy-chain more than 5 Niles amplifiers you will need a Niles ADA-6 buffered distribution amplifier. A single ADA-6 will allow you to daisy-chain 5 amplifiers from each of its six outputs, allowing 30 SI-275 power amplifiers to be fed from the same master preamplifier. If your preamp has a vacuum tube output stage, you must use a Niles ADA-6 to drive more than a single SI-275.

AC Power Plug

| STEP | DESCRIPTION |
|---|---|
| Plug the female IEC socket of the supplied AC cord into the IEC receptacle on the rear of the amplifier. | Just like a computer or printer, the SI-275 has an AC cord which unplugs either at the amp or at the wall for your convenience. |
| Plug the 2 prong plug into a correctly grounded 120V 60 Hz wall outlet. | If you use a grounded power strip, surge suppressor or extension cord, verify that proper ground is maintained. |
| CAUTION! Typically the preamp/receiver's switched outlet is not rated for a power amplifier. | The SI-275 draws a maximum of approximately 700 watts from an AC wall outlet. Use the auto turn on circuit instead. |

OPERATION

Power Switch

The front panel switch is a master or "vacation" power switch. No matter which turn-on mode you have selected, the master power switch will turn off all circuitry—including the sensing circuitry. If you will not be using the amplifier for an extended period of time, turn the master power switch "Off" (push button switch out). When you would like to return to normal operation, turn the switch "On" (push button switch in).

Power LED

The power LED indicates that the AC cord is plugged into a working AC power receptacle and that the power switch is in the "On" position.

Active LED

The rear panel turn-on mode switch determines when and how the amplifier will turn on. The "Active" LED indicates that the amplifier is operating.

Protection LED

The front panel protection LED indicates that the amplifier has been shut down because of either a fault in the wiring or the speaker, or with the SI-275 itself.

Level Adjustment Screws

The front panel level adjustment screws allow you to adjust the level of the SI-275 relative to other amplifiers in your system. Use a 1/8" slotted screwdriver to adjust the screws. If the SI-275 is the only amplifier in your system, leave the screws at their factory default position (turned fully clockwise).

Cleaning and Maintenance

The internal parts of the SI-275 are electronic and require no maintenance. Once a year it is appropriate to twist the RCA connectors on each input to remove corrosion and improve conductivity.

You can clean the amplifier with soft cloth or paper towel dampened with water or a mild detergent. Do not use any spray-type, abrasive cleaners on the amplifier.

TROUBLESHOOTING GUIDE

When there is a problem consult this guide first. If the problem persists, or you have additional questions, call your local Niles dealer or Niles Technical Support at 1-800-289-4434. The most common problems relate to hook up. Call from your telephone extension nearest the system.

| SYMPTOM | POSSIBLE CAUSES AND TEST PROCEDURE |
|---|--|
| <p>No sound on one channel</p> | <p>Short circuit or loose wire at the speaker or amplifier terminals. Check that the connections are secure and that there are no loose strands of wire crossing from the positive to the negative terminals at the back of the amplifier and/or the speaker.</p> <p>Short circuit or a break in the speaker wire. Disconnect the speaker wire at both ends, separate the 2 conductors at both ends and test with a meter for a short circuit. If there is no short, connect the two conductors at one end and test with a meter for continuity.</p> <p>Speaker is not working. Connect the speaker to a channel that plays another speaker.</p> <p>Audio cable to input is bad. Connect another cable that is known to be good.</p> |
| <p>No sound on both channels</p> | <p>Audio cable to the main inputs is bad. Connect another cable that is known to be good.</p> |
| <p>Hum from the speakers</p> | <p>Hum may be caused by a ground loop between two of the other components in the system. To test for another ground loop, try reversing the AC plugs of each of the components in the system.</p> |

TROUBLESHOOTING GUIDE (continued)

| SYMPTOM | POSSIBLE CAUSES AND TEST PROCEDURE |
|---|---|
| Hum from the speakers | Check for faulty cables, faulty source material, an ungrounded phono system or a defective component. |
| Amp will not turn on | AC power cord must be plugged into a working outlet. Master power switch must be on. |
| Bass sound is weak and the stereo image is "phasey" or "blurry" sounding in one room | The loudspeakers are wired out of phase. Reverse the connections at the back of one speaker. |

SPECIFICATIONS

Design Principle

Linear voltage/current amplification.

Continuous Average Power Output

75 watts per channel RMS at 8 ohms.

100 watts per channel RMS at 4 ohms.

Input Impedance

56K ohms

Input Sensitivity

.985V for 8 Ω rated output

Overall Voltage Gain

30 dB

Frequency Response

Bandwidth Limited from 10 Hz to 100 kHz

Total Harmonic Distortion

8 Ohms

.05% THD from 20 Hz to 20 kHz @ full rated power

4 Ohms

.06% THD from 20 Hz to 20 kHz @ full rated power

Overall Dimensions

17" wide 4" high (including feet) 13-1/8" deep

Weight

21 lbs



NILES®

**Niles Audio
Corporation**

www.nilesaudio.com

**12331 S.W. 130 Street
Miami, Florida 33186**

Tel: (305) 238-4373

Fax: (305) 238-0185

© 1999 Niles Audio Corporation. Because Niles strives to continuously improve its products, Niles reserves the right to change product specifications without notice. Niles, the Niles logo and Blending High Fidelity and Architecture are registered trademarks of Niles Audio Corporation. Systems Integration Amplifier and BusMatrix are trademarks of Niles Audio Corporation Printed in the USA 7/98 DS00219B