

## Herculine® 11280S Smart Actuator

## Specification

### Overview

Honeywell's **HercuLine® 11280S Smart** actuators incorporate all of the high quality and reliable features of the traditional **HercuLine®** actuators plus the added benefits of a microprocessor-based Enhanced Electronics Unit (EEU). These additional benefits provide:

- Faster set-up and commissioning
- Network capability
- Health parameter monitoring for proactive maintenance planning.

**HercuLine 11280S Smart** actuators enable operation at maximum process efficiency, minimal downtime, and access to all actuator parameters for real-time business decisions.

Honeywell's 11280S actuators are industrial rated and engineered for very precise positioning of dampers and valves. The **HercuLine 11280S** performs especially well in extremely demanding environments requiring continuous duty, high reliability, and low maintenance. Typical applications are ID/FD fan dampers, furnace pressure dampers, coal mill dampers, burner tilts and more.

### Actuator Operation

Microprocessor-based electronics continually monitor the performance, health, and position of the actuator for repeatable positioning and response to demand signal.

A double reduction worm gear set combines with a variable speed motor controller (inverter) that is continuous duty rated for accurate and repeatable positioning of final control elements.

The worm gear set combination also functions as a brake, capable of holding greater than two times the output torque in a back-driving condition.

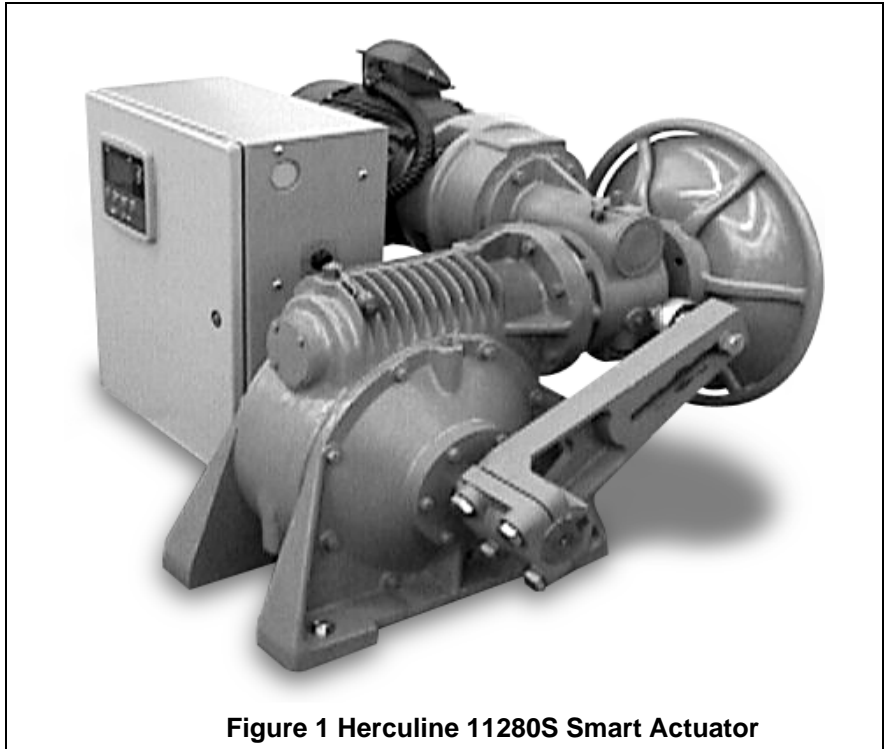

Figure 1 Herculine 11280S Smart Actuator

Control options are available to interface with a modulating 4-20 mA input signal and 4-20 mA customer feedback or remote setpoint through Modbus. Internal balance, customer feedback and patented slidewire emulation is provided by a non-contacting position sensor.

### Features

#### Performance —

- **Accurate Positioning** – Motor/gear train provides accurate positioning with almost instantaneous start/stop characteristics.
- **Non-Contact Position Sensing** – Non-contacting sensing lowers maintenance costs and improves performance.
- **Duty Cycle** – Continuous duty rated motor.

- **Full Travel Speed** – Full stroke travel speeds as fast as 10 seconds.
- **Torque** – High torque capability in small package (425 – 5,500 lb-ft).
- **High Accuracy** – Typically 0.25 % of 90° span.
- **High Repeatability** - Typically 0.2 % of 90° span.
- **Characterization** – Linear, square root or programmable user-configured 21-point characterization allows tailoring of control for specific applications.
- **Input Filter Setting** – Four programmable combinations of input filter settings are provided to accommodate various customers needs. The combinations are none, spike, low pass, or spike + low pass filter.
- **Deadband** – Deadband is programmable between 0.2 % to 5 % of 90° span.

## Features (continued)

### Operation —

- **Control Signals** – 0/4 to 20 mA, 0/1 to 5 Vdc, 0 to 10 Vdc, Digital remote setpoint (RS485 Modbus RTU protocol).
- **Output Signals** – 0/4 to 20 mA, 0/1 to 5 Vdc and slidewire emulation.
- **Manual Operation** – All 11280S series actuators are supplied with a manual handwheel to operate the actuator when power is not available.
- **Auto-Manual** – electric handswitch with auxiliary contacts indicating an "Out-of-Auto" position is available for local electric control.
- **RS485/Modbus RTU Communication** – Simple and easy to use Modbus RTU communication is standard with all 11280S actuators allowing seamless networking of Honeywell control products.
- **Auxiliary Outputs** – Two types of auxiliary outputs can be specified, SPDT switches or electromechanical relay outputs. Relay outputs can be programmed to output alarm conditions, provide control of other equipment, or indicate status.
- **Alarm Functions** – Alarms may be assigned to relay outputs or may be accessed through Modbus. Alarms can be triggered from stall, temperature limits, motor cycle count, out of automatic mode, digital input, position, input failure, position sensor failure, power up failure, and more.
- **Local HMI Configuration** – An integral keypad and high intensity display is available for non-intrusive local configuration of the actuator (Figure 2).
- **Configuration Security** – Password protection is provided, allowing users to lock out some, all, or no groups of setup parameters to prevent tampering.

- **Factory Calibration** – Factory calibration is stored in non-volatile memory and can be restored via the local HMI at any time.
- **Direction of Rotation** – Direction of rotation on increasing input signal is programmable.
- **Split Range Operation** – Split range is programmable and infinitely adjustable.
- **Digital Input Override** – A digital input is provided and is programmable to provide override of all other input signals as an emergency override of control. The digital input can be programmed to drive the actuator open, closed, remain in-place, or to a user-specified position on contact closure.
- **Failsafe** – When input signal exceeds high or low range limits (or input signal failure), the actuator can be programmed to drive open, closed, remain in-place, or drive to a user-specified position.

### Construction —

- **Enclosure** – Rugged, industrial grade enclosure.
- **Low Maintenance** – Simple-proven design means high reliability/low maintenance.
- **Output Shaft Hardware** – All 11280S series actuators are supplied with an adjustable radius crank arm. Optional linkage kits are available.
- **Limit Switches** – Two end-of-travel electric limit switches are supplied as standard equipment with all 11280S series actuators.
- **Warranty** – Exceptional warranty.

## Health Monitoring

A standard feature on all 11280S actuators accumulates information about actuator operation. This information then can be used to evaluate and determine predicted or scheduled maintenance periods. The parameters that are monitored include: accumulated stall time, thermal operating rating of the actuator exceeded, number of motor starts in a region of motor travel, total travel and current actuator travel.

### Non-Contact Position Sensing

Honeywell 11280S series actuators implement a variable inductance, non-contact position sensor mounted directly to the actuator output shaft providing precision position sensing from 0 to 90 degrees, (Figure 3). This technology eliminates maintenance items such as wipers, bearings, as well as static friction, hysteresis and electrical noise over a wide range of demanding environmental conditions.

### Slidewire Emulation

The Slidewire Emulation Circuit (SEC) emulates the proportional voltage output of a typical slidewire through a high impedance circuit. The voltage output is proportional to the supply voltage and shaft position. A non-contact position sensor is used to determine shaft position in place of the slidewire.

## Local Display and Keypad

Configuration and set-up is through the local HMI, consisting of a display and keypad interface (Figure 2). A high intensity 10-character LED display and simple pushbuttons provide quick access for actuator set up and status information. If relay outputs are specified, all configuration can be done through either the local HMI interface. If mechanical switches are specified, then the user must manually set the auxiliary output.

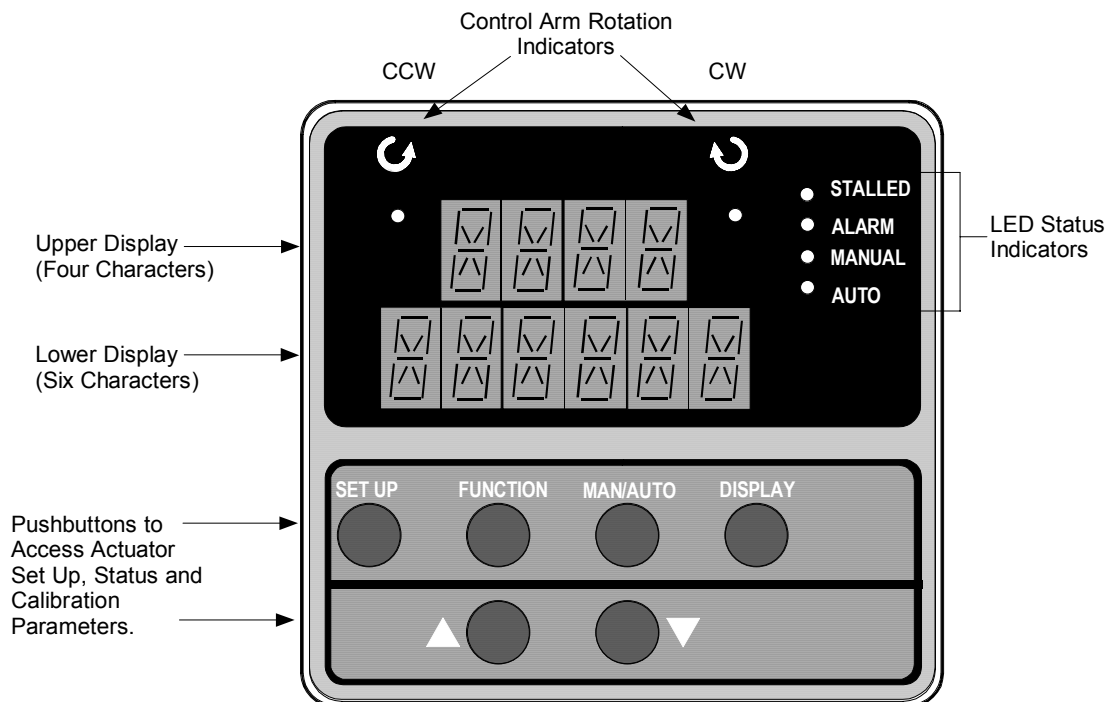

**Figure 2 Local HMI (Display and Keypad)**

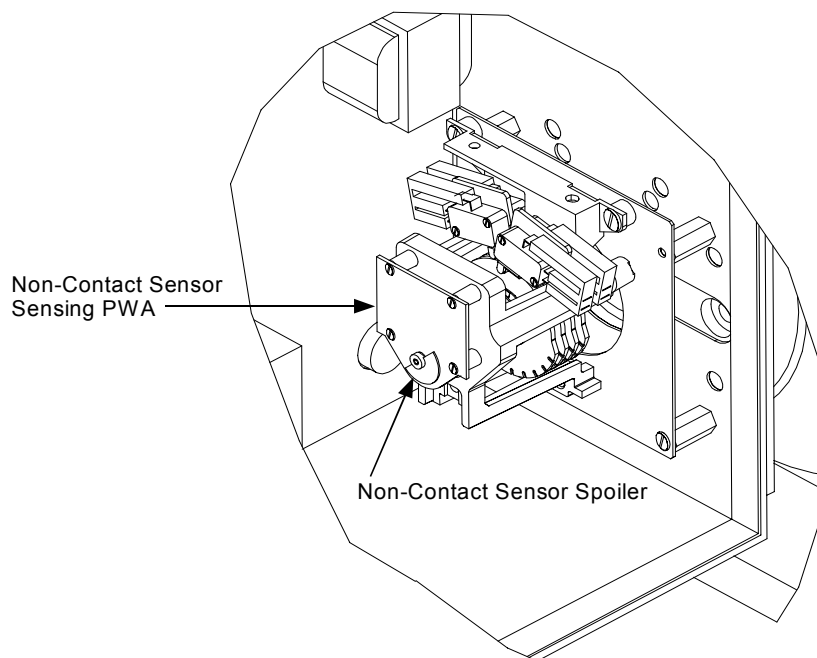

**Figure 3 Non-Contact Sensor Assembly**

## Set Up/Configuration Parameters

Configuration parameters are logically grouped and accessed using the local HMI. Actuator calibration is also accomplished through a simple procedure using the keypad. By pressing the SETUP button on the HMI, you can step through the set up groups that contain all of the configuration parameters. The table below summarizes the configuration parameters available within the various set up groups. Full details of all configuration parameters are found in the *11280S Series Smart Actuator Installation, Operation and Maintenance Manual*, document number 61-86-25-09.

Set Up Group	Configuration Parameter Selections/Settings	
<p><b>SET INPUT</b>— Selects various parameters that define actuator operation.</p>	<p>IN TYP – Input Actuation Type                      INP HI – Input High Range Value                      INP LO – Input Low Range Value                      FILTYP – Input Filter Type                      LPFILT – Low Pass Filter Time Constant                      Direct – Actuator Rotation</p>	<p>Dband – Input Deadband                      FsTYP – Failsafe Type                      FsVAL – Failsafe Value                      CHAR – Input Characterization                      LDCAL – Restore Calibration Type</p>
<p><b>SET RELAY</b>— When the actuator is equipped with optional relays, this set up group allows you to set relay action for various actuator operating conditions. Contact closure can be wired to external annunciators or alarm points to indicate conditions for any of the Relay Types.</p>	<p>RTYPnn – Relay Type                      Input Range                      Position Range                      Deviation                      Upper or Lower Limit Travel                      Temperature High or Low                      Motor Starts                      Motor Stalled                      Manual Mode                      Power Up Test Failure                      Input Signal Failure                      Position Sensor Signal Failure                      Digital Input Closure</p>	<p>RnnE – Relay Count Multiplier                      RnnVAL – Relay Value                      Rnn HL – Relay High/Low                      RLYnHY – Relay Hysteresis</p>
<p><b>SET CUROUT</b>— Selects the current (or voltage) output range of the actuator.</p>	<p>CUROUT - Output Signal Range                      4 – 20 mA,    0 – 20 mA,                      1 – 5V,        0 – 5V,                      SW E (Slidewire Emulation)</p>	
<p><b>SET COMM</b>— Actuator can be defined as a master or slave device on a Modbus RTU RS-485 loop. Operating setpoint can be transmitted to the actuator and operating status can be read when connected to supervisory control systems.</p>	<p>COMM – Communications Parameters                      ADDRES – Device Address                      BAUD – Baud Rate                      XmtDLY – Response Delay                      DBLBYT – Floating Point Data Format</p>	
<p><b>SET DIGINP</b>— Selects digital input action upon contact closure.</p>	<p>DIGINP – Digital Input State                      Endpos – End Position Value</p>	
<p><b>SET DISPLA</b>— Selects desired decimal places and engineering units for local display.</p>	<p>DECMAL – Decimal Point Location                      EUNITS – Units Display                      UNITS – Display Units</p>	
<p><b>CAL INPUT, MTR, CURENT</b>— If needed, calibration of the actuator input, motor position and actuator output can be performed using the local keypad and display.</p>		

Continued on next page ⇒

Set Up Group	Configuration Parameter Selections/Settings	
<b>SET LOCK</b> — Enables lock out or access to selected set up group parameters and calibration values.	LOCKID – Set Security Password LOCK – Lock Out	
<b>READ STATUS</b> — Displays failsafe condition and the results of various diagnostics performed during power up.	FAILSF – Failsafe RAMTST – RAM Test Diagnostic SEETST – Serial EEPROM Test Diagnostic	CFGTST – Configuration Test Diagnostic CALTST – Calibration Test Diagnostic
<b>SET DRVIN</b> — Allows access to actuator device information.	VERSON – Firmware Version SPEED – Stroke Speed POWER – Power Input Voltage and Line Frequency TAG – Tag Name	MFGDAT – Manufacturing Date LREP – Date of Last Repair LCAL – Date of Last Field Calibration REPTYP – Repair Type
<b>SET MAINT</b> — Allows access to parameters that monitor operating conditions.	TEMP – Actuator Temperature TEMPHI – High Temperature Limit TEMPLO – Low Temperature Limit ACST – Accumulated Motor Stall Time STARTS – Accumulated Motor Starts	RLnCNTS – Relay Cycle Counts REGNn – Accumulated Motor Starts (Regions of Travel) TOTDEG – Total Degrees of Motor Travel MANRST – Reset Maintenance Statistics

### Specifications – General

Physical	
<b>Enclosure</b>	Precision-machined ductile iron with corrosion resistant paint
<b>Gear Train</b>	Precision-machined double reduction worm gear
<b>Operating Temperature</b>	-30 °C to +65 °C (-20 °F to +150 °F) except Model 11287S which has a range of: -20 °C to +65 °C (-4 °F to +150 °F)
<b>Storage Temperature</b>	-40 °C to +93 °C (-40°F to +200 °F)
<b>Relative Humidity</b>	0-99% R.H. noncondensing, over the full operating temperature range.
<b>Crank Arm</b>	Adjustable radii (8" to 14") crank arm is standard
<b>Rotation</b>	Factory set to 90 degrees, for 0% to 100% travel
<b>Direction of Rotation</b>	Field programmable via local display and keypad
<b>Manual Handwheel</b>	Provides a means of positioning the actuator in the event of a power failure or set-up
<b>Lubrication</b>	Mobil Synthetic bearing and gear lubricant SHC 634 (ISO 460) or equivalent
<b>Weight</b>	300 lb to 600 lb (136 kg to 272 kg)—See Table below for more information.

Specifications continued on next page ⇒

### Specifications – General, Continued

Physical							
Model #	Torque lb-ft (N_M)	Output Shaft Size	Shaft Key Size	Output Shaft Length	Maximum Overhang Load	Handwheel Diameter	Approx. Maximum Weight
11284S	425 (576)	2" (51 mm)	1/2" (13 mm)	5" (127 mm)	3700 lb. (1678 kg)	18" (457 mm)	300 lb. (136 kg)
11285S	840 (1139)	2" (51 mm)	1/2" (13 mm)	5" (127 mm)	3700 lb. (1678 kg)	18" (457 mm)	300 lb. (136 kg)
11286S	1500 (2033)	2" (51 mm)	1/2" (13 mm)	5" (127 mm)	3700 lb. (1678 kg)	18" (457 mm)	300 lb. (136 kg)
11288S	2500 (3389)	2-1/2" (64 mm)	5/8" (16 mm)	6" (152 mm)	7500 lb. (3402 kg)	18" (457 mm)	550 lb. (251 kg)
11289S	4000 (5423)	2-1/2" (64 mm)	5/8" (16 mm)	6" (152 mm)	7500 lb. (3402 kg)	18" (457 mm)	600 lb. (272 kg)
11287S	5500 (7457)	2-1/2" (64 mm)	5/8" (16 mm)	6" (152 mm)	7500 lb. (3402 kg)	18" (457 mm)	600 lb. (272 kg)

Electrical			
<b>Mains Supply</b>	115/220 Vac, single phase 50/60 Hz up to 1500 lb-ft 208/200 – 240/380 – 480/575 Vac, three phase 50/60 Hz		
<b>Motor</b>	Inverter rated, continuous duty, C face mounting		
<b>Motor Current</b>	<b>Motor Size</b>	<b>Full Load Amps (FLA)</b>	
	<b>(Horsepower)</b>	<b>@ 230 Vac</b>	<b>@ 460 Vac</b>
	1/2	1.6	0.8
	3/4	2.2	1.1
	1	2.6	1.3
	1 1/2	4.4	2.2
	2	5.6	2.8
	3	7.8	3.9
<b>Loss of Power</b>	Stays in place		
<b>Local Auto - Manual Switch</b>	Allows local manual and automatic operation of the actuator		
<b>Limit Switches</b>	Standard - Two SPDT end-of-travel limits rated 10 A at 125 Vac, 5 A at 250 Vac.		
<b>Auxiliary Switches/Relays</b>	Optional – Up to 2 additional SPDT switches (or 4 relay outputs, programmable)		
<b>Installation Category</b> (Overvoltage Category)	Category II: Energy-consuming equipment supplied from the fixed installation. Local level appliances, and industrial control equipment. (EN 61010-1)		
<b>Pollution Degree</b>	Pollution degree 2: Normally non-conductive pollution with occasional conductivity caused by condensation. (ref. IEC 664-1)		

## Specifications – Actuator

Electrical		
<b>Input Signals</b>	<b>Analog:</b> 0/4 to 20 mA (With supplied 250 ohm shunt resistor for current range) 0/1 to 5 Vdc 0 to 10 Vdc  <b>Digital:</b> Remote Setpoint via Modbus RTU (RS485)	
<b>Input Impedance</b>	<b>Input</b>  0/4 to 20 mA  0/1 to 5 Vdc	<b>Input Impedance</b>  250 ohms  10 K ohms
<b>Input Characterization</b>	Provides characterization of the input signal. Selections are: Linear, Square Root or Custom.	
<b>Sensitivity</b>	0.2 % to 5 % of 90° span, proportional to deadband	
<b>Hysteresis</b>	Less than 0.4 % of full scale	
<b>Deadband</b>	0.2 % to 5 % of 90° span, adjustable. Shipped at 0.5%	
<b>Repeatability</b>	0.2 % of 90° span	
<b>Voltage/ Supply Stability</b>	0.25 % of span with +10/-15 % voltage change	
<b>Temperature Coefficient</b>	Less than ± 0.030 % of span per degree C for 0 °C to 50 °C  Less than ± 0.05 % of span per degree C for -30 °C to 65 °C	
<b>Zero Suppression</b>	90% of span	
<b>Input Filters</b>	Selectable spike and low pass filters	
<b>Solid State Motor Control</b>	CW/CCW open collectors (opto-isolators) for use as discrete control inputs to the inverter for motor operation.	
<b>Failsafe operation</b>	If input signal exceeds configured input range. Selectable and adjustable.	
<b>Feedback signals/Output</b>	0 to 20 mA, 4 to 20 mA  0 to 5 Vdc, 1 to 5 Vdc with 250 ohm resistor; (0 to 16 Vdc with 800 ohm resistor)	
<b>Slidewire Emulation</b>	Provides output voltage ratiometric to shaft position and potentiometric to supply voltage (1 to 20 Vdc) without a slidewire. Emulates a 100 ohm to 1000 ohm slidewire. 10 mA output maximum.	
<b>Isolation</b>	Input signal, output signal and power are isolated from each other.	
<b>Load Requirement (4-20)</b>	Current Out — 0 to 1000 ohms	
<b>Programmable Functions</b>	Selectable and configurable operating parameters: <ul style="list-style-type: none"> <li>• Input range</li> <li>• Input filtering</li> <li>• Input characterization</li> <li>• Security</li> <li>• Digital Input action</li> <li>• Deadband</li> <li>• Failsafe on loss of input signal</li> <li>• Failsafe on loss of position sensor</li> <li>• Direction of rotation</li> <li>• Relay closure action</li> <li>• Communication parameters</li> <li>• Split range operation</li> <li>• Output range</li> <li>• Alarms</li> </ul>	

## Pipe Linkage Kit

Pipe linkage kits are available from Honeywell and can be used for linkage lengths from 24 to 240 inches (61 to 610 cm). The kits include the mechanical pipe couplings, load rod end (left-hand thread), connecting rods and locking nuts. See Figure 4. The actuator rod end (right-hand thread), nut and bolt are supplied with the actuator. The customer must supply a piece of schedule 40 pipe 2 1/2" \* (both ends with right-hand NP threads) and a nut and bolt to connect the rod end to the load. Pipe linkage kits can be ordered with the Actuator using Table VIII of the Model Selection Guide.

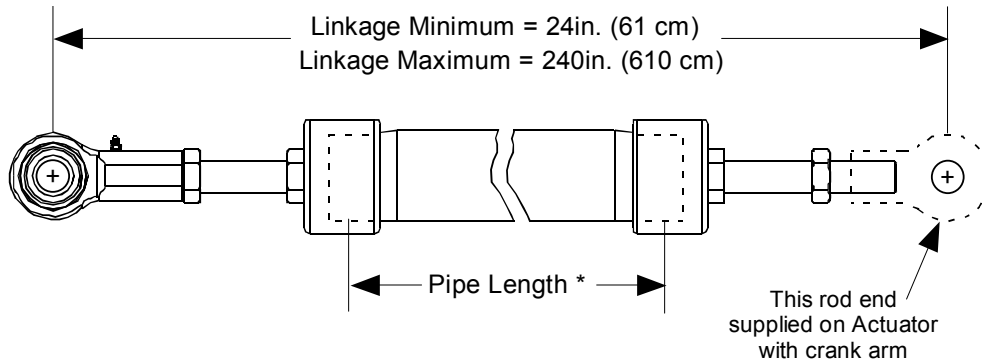

\*Pipe length = Overall linkage length minus (-) 20 inches (51 cm).

**Figure 4 Pipe Linkage Kit**

## Actuator Crank Arm

The 11280S Series Actuator comes standard with an 8" to 14" adjustable radius crank arm. The crank arm uses a standard right-hand thread 1" rod end to compliment the pipe linkage kit.

The crank arm for the 11284S, 11285S and 11286S has a 2" shaft hole, while the crank arm from the 11287S, 11288S and 11289S has a 2 1/2" shaft hole.

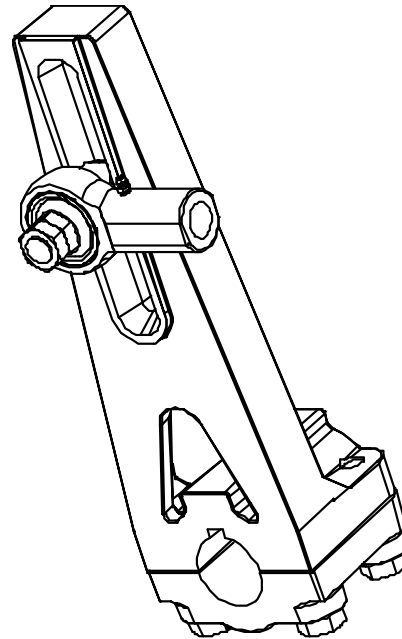

**Figure 5 11280S Crank Arm**

### Recommended Bolt Torque

The table below lists the type of bolts to be used and the recommended torque for each bolt.

Bolt Type	Torque
Clamp bolts	220 lb.-ft
Rod End Bolt	220 lb.-ft
Jam nuts	100 lb.-ft



## External Transformers

### 120 Vac (Single Phase)

For customer applications requiring 120/240 Vac single phase operation, a step-up transformer is mounted in a separate enclosure (Model Selection Guide Table I, option 1). Figure 6 shows the installation for the transformer enclosure.

### 575 Vac (3 Phase)

For customer applications requiring 575/460 Vac 3 phase operation, a step-down transformer is mounted in a separate enclosure (Model Selection Guide Table I, option 6). Figure 6 shows the installation for the transformer enclosure.

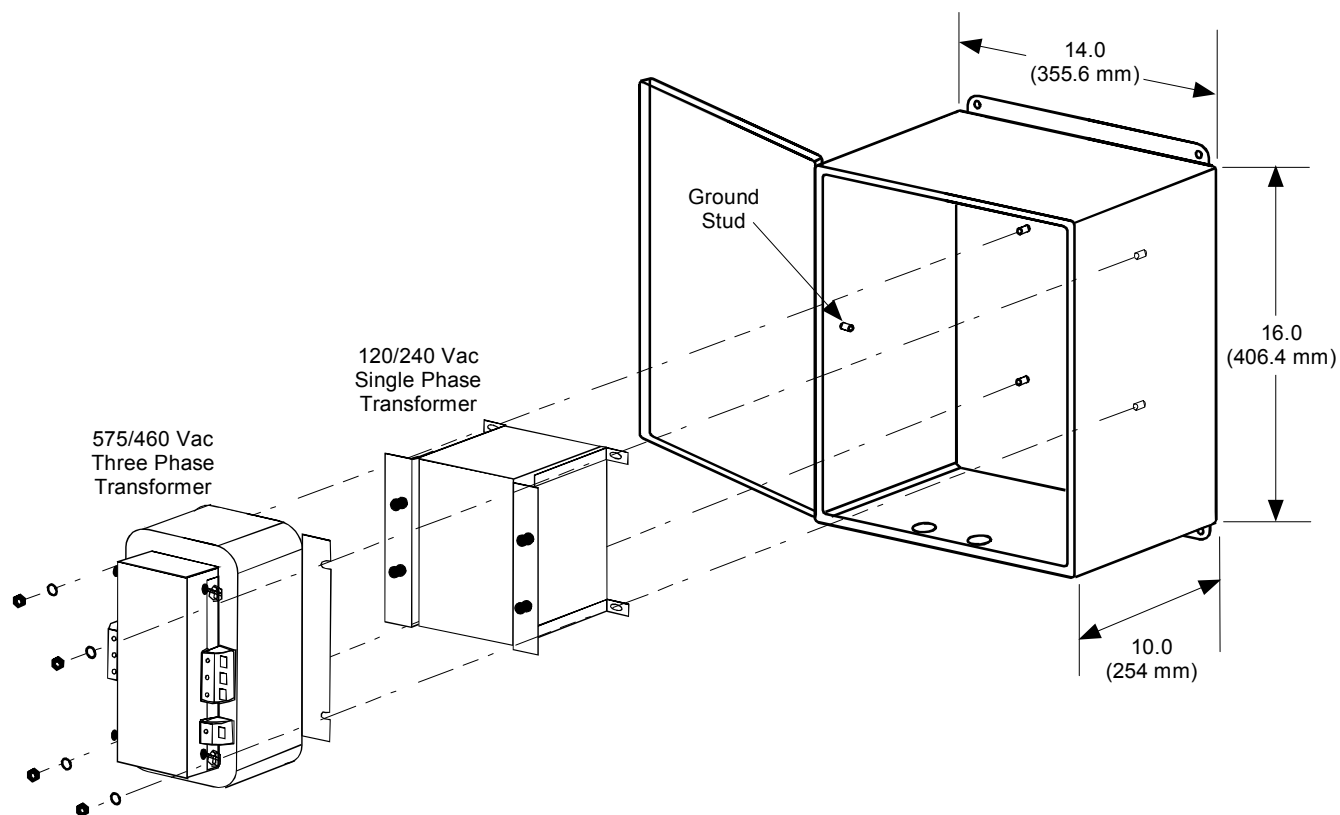

Figure 6 Installation Drawing for External Transformer Enclosure

## Model Selection Guide

Reference 62-86-16-19

### Instructions

- Select the desired key number. The arrow to the right marks the selection available.
- Make the desired selections from Tables I thru VIII using the column below the arrow.  
A dot (•) denotes unrestricted availability.

Key Number	I	II	III	IV	V	VI	VII	VIII	IX

### KEY NUMBER - Electronics

Output Torque (lb. - ft.) (N - M)		Selection	Availability	
425 (575)	<b>(Note 1)</b>	011284S	↓	
850 (1150)		011285S	↓	
1500 (2025)		011286S	↓	
2500 (3400)		011288S	↓	
4000 (5425)		011289S	↓	
5500 (7450)		011287S		↓

**TABLE I - POWER SUPPLY**

Single Phase	120 Vac, 50/ 60 Hz	1	a	
	240 Vac, 60 Hz / 200 Vac, 50 Hz	2	a	
Three Phase	200 - 240 Vac, 60 Hz	4	•	•
	380 - 480 Vac, 50-/60 Hz	5	•	•
	575 Vac, 60 Hz	6	•	•

**TABLE II - STROKE SPEED**

Stroke Speed @ 60 Hz	10 sec/90 degrees	1	•	
	30 sec/90 degrees	2	•	•
	60 sec/90 degrees	3	•	•

**TABLE III - MOTOR ORIENTATION** (See specification 61-86-03-13 for diagrams)

Motor	Right-hand floor configuration, H.W. Shaft Horizontal	01	•	•
Orientation	Left-hand floor configuration, H.W. Shaft Horizontal	03	•	•

**TABLE IV - ANALOG INPUT/OUTPUT SIGNALS**

Input	4-20 mA, 0-20mA (1-5 Vdc, 0-5 Vdc, 1-10 Vdc, 0-10Vdc)	0__	•	•
Output	No Analog Position Output	_00	•	•
	4-20 mA, 0-20mA (1-5 Vdc, 0-5 Vdc, 1-10 Vdc, 0-10Vdc)	_20	•	•
	Slidewire Emulation <span style="float: right;"><b>(Note 2)</b></span>	_40	•	•

**Model Selection Guide, continued**

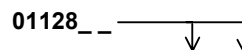
01128 \_ \_ 

**TABLE V - SWITCH AND RELAY OUTPUTS** (2 mech end-of-travel limits standard)

		Selection	4S	5S	6S	8S	9S	7S
Auxiliary Switches and	None	00 _	•	•				
	2 Aux. SPDT Switches	20 _	•	•				
	2 Aux. + 2 Programmable Relay Outputs	22 _	•	•				
	2 Programmable Relay Outputs	02 _	•	•				
	4 Programmable Relay Outputs	04 _	•	•				
Auto/Manual Switch	None	_ _ 0	•	•				
	One Auto/Manual Switch with Out-of-Auto Contact	_ _ 1	•	•				

**TABLE VI - CONFIGURATION INTERFACE**

Remote	None	0		
Local	Integrally mounted local display/keypad interface	1	•	•

**TABLE VII - COMMUNICATIONS/PROTOCOL**

Modbus RTU RS485	RS-485 Modbus compliant - standard with EEU	0	•	•
Additional Communications	Future	1		

**TABLE VIII - OPTIONS**

Crank Arm	Adjustable 8" to 14" Radii - Standard	0 _ _ _ _	•	•
	None	1 _ _ _ _	•	•
Linkage Kit	None	_ 0 _ _ _	•	•
	Up to 20 ft. length - customer supplies schedule 40 pipe	_ 1 _ _ _	•	•
Future Option	None	_ _ 0	•	•
Future Option	None	_ _ _ 0	•	•
Tagging	None	_ _ _ _ 0	•	•
	Linen <b>(Note 3)</b>	_ _ _ _ 1	•	•
	Stainless Steel <b>(Note 3)</b>	_ _ _ _ 2	•	•
Future Option	None	_ _ _ _ 0	•	•

**TABLE IX - FACTORY OPTIONS**

Motor Orientation	None	00	•	•
-------------------	------	----	---	---

**RESTRICTIONS**

Restriction Letter	Table	Available Only With	Not Available With	
		Selection	Table	Selection
a	I	11284S, 11285S, 11286S	I	11287S, 11288S, 11289S

**Note 1:** Requires (2) adapters PN 51204694-501 for retrofit of existing Leeds & Northrup 011284 and 011285 actuators.

**Note 2:** Slidewire emulation is a solid state circuit providing a ratiometric voltage output proportional to shaft position.

**Note 3:** Customer must supply tagging information: Up to 3 lines (22 characters for each line)

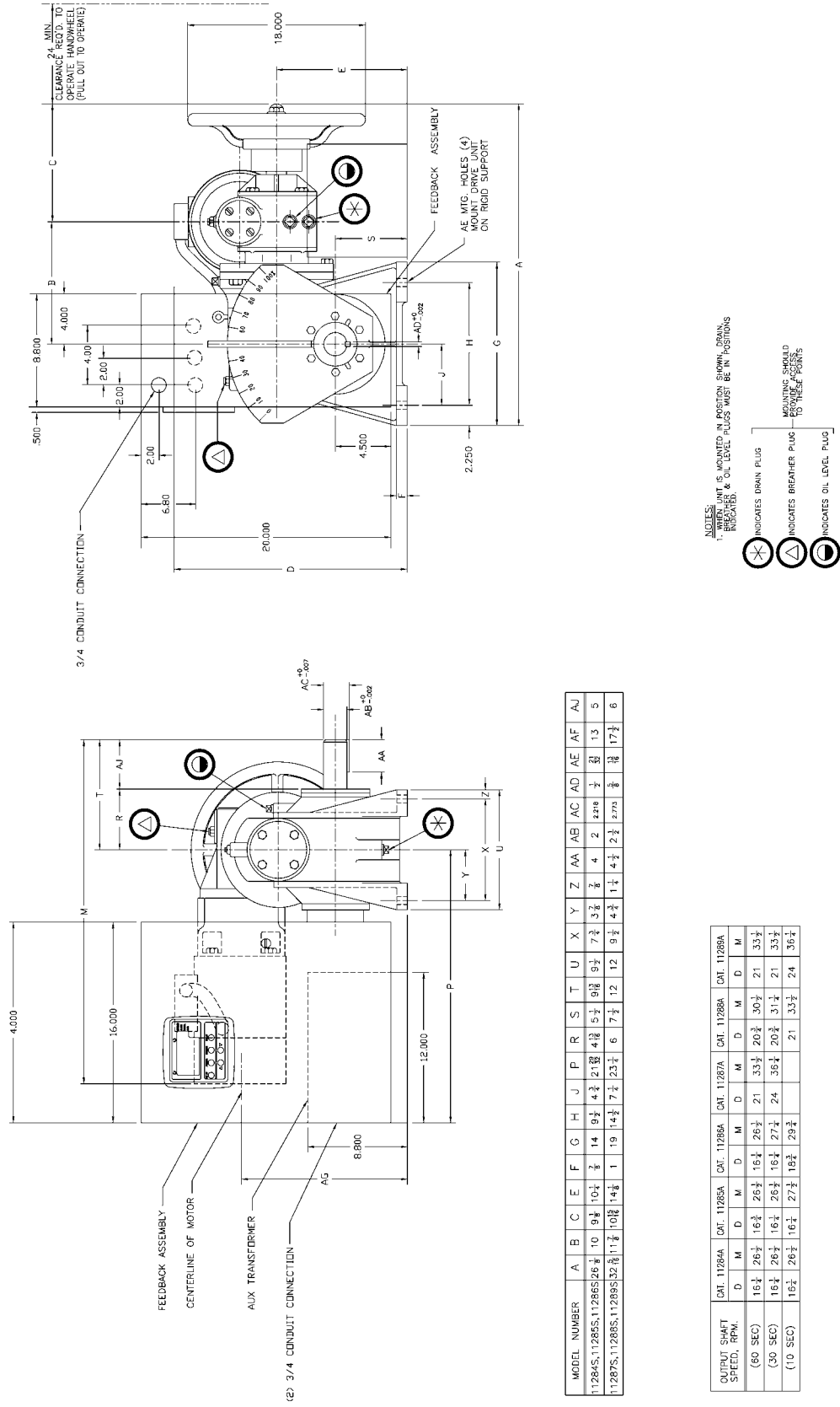

MODEL NUMBER	A	B	C	E	F	G	H	J	P	R	S	T	U	X	Y	Z	AA	AB	AC	AD	AE	AF	AJ
11284S, 11285S, 11286S, 26 3/4	10	9 1/2	10 1/4	10 1/8	14	9 1/2	4 3/4	2 1/8	4 1/8	5 1/2	9 1/2	9 1/2	9 1/2	7 3/4	5 3/8	7 1/2	4	2	2 1/2	2 1/2	2 1/2	2 1/2	17 1/2
11287S, 11288S, 11289S, 32 1/2	11 1/2	10 1/2	11 1/4	10 3/4	14 1/2	19	14 1/2	7 1/2	2 3/4	6	7 1/2	12	12	9 1/2	4 3/4	1 1/2	4 1/2	2 1/2	2 1/2	2 1/2	2 1/2	2 1/2	17 1/2

OUTPUT SHAFT SPEED, RPM.	CAT. 11284A	CAT. 11285A	CAT. 11286A	CAT. 11287A	CAT. 11288A	CAT. 11289A
(60 SEC)	16 1/4	26 1/2	16 1/4	26 1/2	16 1/4	26 1/2
(30 SEC)	16 1/4	26 1/2	16 1/4	26 1/2	16 1/4	26 1/2
(10 SEC)	16 1/4	26 1/2	16 1/4	26 1/2	16 1/4	26 1/2

Figure 7 Mounting and Outline Dimensions for 11284S, 11285S, 11286S, 11288S, and 11289S Weather-Proofed Motor Actuators - Right Hand Floor Mounting, Handwheel Shaft Horizontal (D-MTG-616-200)

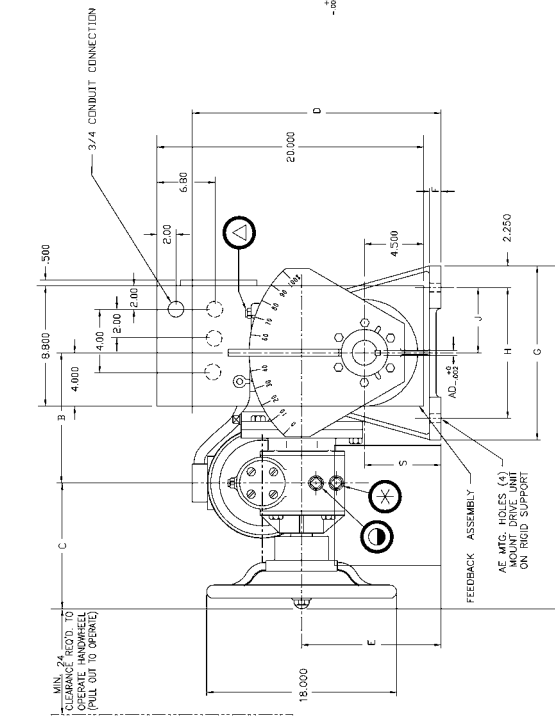
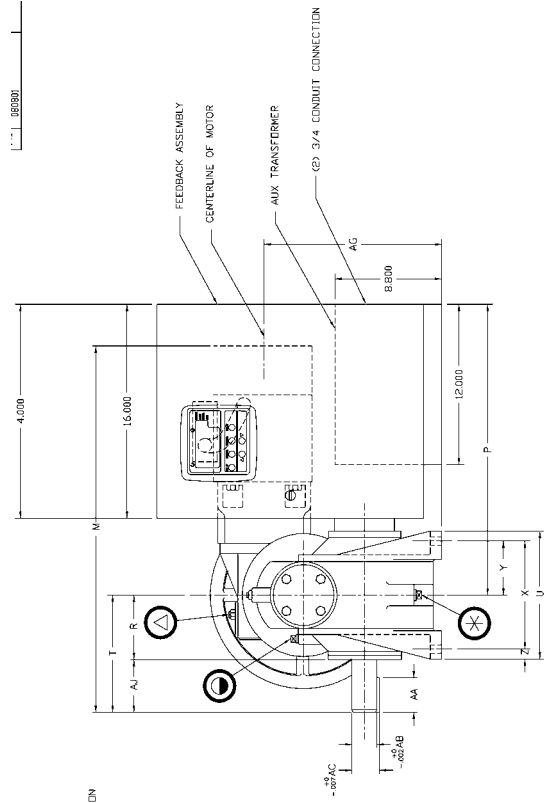

MODEL NUMBER	A	B	C	E	F	G	H	J	P	R	S	T	U	X	Y	Z	AA	AB	AC	AD	AE	AF	AJ
11284S, 11285S, 11286S	26 1/2	10 1/2	14	9 1/2	4 1/2	21 1/8	4 1/2	5 1/2	19 1/2	4 1/2	7 1/2	12	12	9 1/2	4 1/2	1 1/4	4 1/2	2 1/2	2 3/4	2 1/2	2 1/2	13	5
11287S, 11288S, 11289S	32 1/8	11 1/2	16 1/2	14 1/2	19	14 1/2	7 1/2	23 1/2	6	7 1/2	12	12	12	9 1/2	4 1/2	1 1/4	4 1/2	2 1/2	2 3/4	2 1/2	2 1/2	17 1/2	6

NOTES:  
1. WHEN UNIT IS MOUNTED IN POSITION SHOWN, DRAIN PLUGS AND OIL LEVEL HOLES MUST BE IN POSITIONS INDICATED.

⊗ INDICATES DRAIN PLUG  
⊙ INDICATES BREAKER PLUG  
⊕ INDICATES OIL LEVEL PLUG

OUTPUT SHAFT SPEED, RPM.	CAT. 11284A	CAT. 11285A	CAT. 11286A	CAT. 11287A	CAT. 11288A	CAT. 11289A
(60 SEC)	16 1/2	26 1/2	26 1/2	26 1/2	33 1/2	30 1/2
(30 SEC)	16 1/2	26 1/2	26 1/2	26 1/2	33 1/2	30 1/2
(10 SEC)	16 1/2	26 1/2	26 1/2	26 1/2	33 1/2	30 1/2

Figure 8 Mounting and Outline Dimensions for 11284S, 11285S, 11286S, 11288S, and 11289S Weather-Proofed Motor Actuators - Left Hand Floor Mounting, Handwheel Shaft Horizontal (D-MTG-616-210)

---

## Warranty/Remedy

---

Honeywell warrants goods of its manufacture as being free of defective materials and faulty workmanship. Contact your local sales office for warranty information. If warranted goods are returned to Honeywell during the period of coverage, Honeywell will repair or replace without charge those items it finds defective. The foregoing is Buyer's sole remedy and is **in lieu of all other warranties, expressed or implied, including those of merchantability and fitness for a particular purpose**. Specifications may change without notice. The information we supply is believed to be accurate and reliable as of this printing. However, we assume no responsibility for its use. © Honeywell 2004.

While we provide application assistance personally, through our literature and the Honeywell web site, it is up to the customer to determine the suitability of the product in the application.

---

Distributor :



Tlf: 67150 250 Faks: 67 150 251

Mail: [post@instrumentteam.no](mailto:post@instrumentteam.no)

Web: [www.instrumentteam.no](http://www.instrumentteam.no)

---

**Honeywell**

**Sensing and Control**  
Honeywell  
11 West Spring Street  
Freeport, IL 61032