

JVC



DIGITAL MEDIA SYSTEM

TH-L1

Consists of AX-THL1, SP-THL1W,
SP-THL1F, SP-THL1C and SP-THL1S

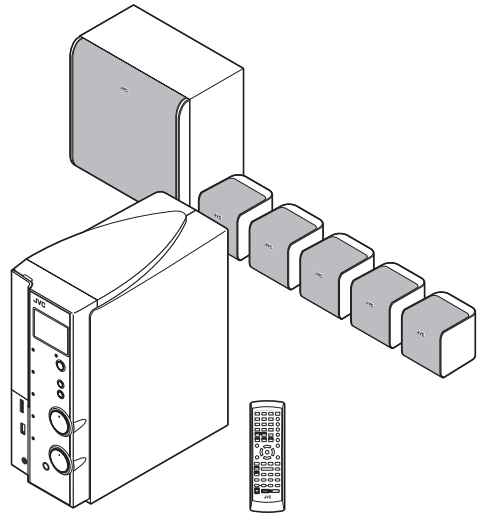

HDMI



Digital Direct Progressive Scan

MPEG-4
ASF PLAYBACK

INSTRUCTIONS

For Customer Use:

Enter below the Model No. and Serial No. which are located either on the rear, bottom or side of the cabinet. Retain this information for future reference.

Model No. _____

Serial No. _____

Warnings, Cautions and Others

Mises en garde, précautions et indications diverses

	CAUTION RISK OF ELECTRIC SHOCK DO NOT OPEN	
CAUTION: TO REDUCE THE RISK OF ELECTRIC SHOCK, DO NOT REMOVE COVER (OR BACK). NO USER SERVICEABLE PARTS INSIDE. REFER SERVICING TO QUALIFIED SERVICE PERSONNEL.		



The lightning flash with arrowhead symbol, within an equilateral triangle, is intended to alert the user to the presence of uninsulated "dangerous voltage" within the product's enclosure that may be of sufficient magnitude to constitute a risk of electric shock to persons.



The exclamation point within an equilateral triangle is intended to alert the user to the presence of important operating and maintenance (servicing) instructions in the literature accompanying the appliance.

	ATTENTION RISQUE D'ÉLECTROCUTION NE PAS OUVRIR	
ATTENTION: POUR ÉVITER TOUT RISQUE D'ÉLECTROCUTION, NE PAS OUVRIR LE BOÎTIER. AUCUNE PIÈCE INTÉRIEURE N'EST À RÉGLER PAR L'UTILISATEUR. SE RÉFÉRER À UN AGENT QUALIFIÉ EN CAS DE PROBLÈME.		



Le symbole de l'éclair à l'intérieur d'un triangle équilatéral est destiné à alerter l'utilisateur sur la présence d'une "tension dangereuse" non isolée dans le boîtier du produit. Cette tension est suffisante pour provoquer l'électrocution de personnes.



Le point d'exclamation à l'intérieur d'un triangle équilatéral est destiné à alerter l'utilisateur sur la présence d'opérations d'entretien importantes au sujet desquelles des renseignements se trouvent dans le manuel d'instructions.

WARNING: TO REDUCE THE RISK OF FIRE OR ELECTRIC SHOCK, DO NOT EXPOSE THIS APPLIANCE TO RAIN OR MOISTURE.

CAUTION— button!

Disconnect the mains plug to shut the power off completely (the STANDBY lamp goes off). When installing the apparatus, ensure that the plug is easily accessible.

The  button in any position does not disconnect the mains line.

- When the system is on standby, the STANDBY lamp lights red.
- When the system is turned on, the STANDBY lamp goes off.

The power can be remote controlled.

ATTENTION— Touche

Déconnectez la fiche secteur pour mettre l'appareil complètement hors tension (le témoin STANDBY s'éteint). Lors de l'installation de l'appareil, assurez-vous que la fiche soit facilement accessible.

La touche , dans n'importe quelle position, ne déconnecte pas le système du secteur.

- Quand le système est en attente, le témoin STANDBY est allumé en rouge.
- Quand le système est sous tension, le témoin STANDBY s'éteint.

L'alimentation peut être télécommandée.

CAUTION

To reduce the risk of electrical shocks, fire, etc.:

1. Do not remove screws, covers or cabinet.
2. Do not expose this appliance to rain or moisture.

ATTENTION

Afin d'éviter tout risque d'électrocution, d'incendie, etc.:

1. Ne pas enlever les vis ni les panneaux et ne pas ouvrir le coffret de l'appareil.
2. Ne pas exposer l'appareil à la pluie ni à l'humidité.



[European Union only]
[Union européenne seulement]

For U.S.A.

This equipment has been tested and found to comply with the limits for a Class B digital device, pursuant to part 15 of the FCC Rules. These limits are designed to provide reasonable protection against harmful interference in a residential installation.

This equipment generates, uses and can radiate radio frequency energy and, if not installed and used in accordance with the instructions, may cause harmful interference to radio communications. However, there is no guarantee that interference will not occur in a particular installation. If this equipment does cause harmful interference to radio or television reception, which can be determined by turning the equipment off and on, the user is encouraged to try to correct the interference by one or more of the following measures: Reorient or relocate the receiving antenna.

- Increase the separation between the equipment and receiver.
- Connect the equipment into an outlet on a circuit different from that to which the receiver is connected.
- Consult the dealer or an experienced radio/TV technician for help.

CAUTION

Changes or modifications not approved by JVC could void the user's authority to operate the equipment.

CAUTION

Excessive sound pressure from earphones or headphones can cause hearing loss.

ATTENTION

Une pression acoustique excessive des écouteurs ou du casque d'écoute peut entraîner une perte auditive.

For Canada/pour le Canada

THIS DIGITAL APPARATUS DOES NOT EXCEED THE CLASS B LIMITS FOR RADIO NOISE EMISSIONS FROM DIGITAL APPARATUS AS SET OUT IN THE INTERFERENCE-CAUSING EQUIPMENT STANDARD ENTITLED "DIGITAL APPARATUS," ICES-003 OF THE DEPARTMENT OF COMMUNICATIONS.

CET APPAREIL NUMERIQUE RESPECTE LES LIMITES DE BRUITS RADIOELECTRIQUES APPLICABLES AUX APPAREILS NUMERIQUES DE CLASSE B PRESCRITES DANS LA NORME SUR LE MATERIEL BROUILLEUR; "APPAREILS NUMERIQUES", NMB-003 EDICTEE PAR LE MINISTRE DES COMMUNICATIONS.

CAUTION

- Do not block the ventilation openings or holes. (If the ventilation openings or holes are blocked by a newspaper or cloth, etc., the heat may not be able to get out.)
- Do not place any naked flame sources, such as lighted candles, on the apparatus.
- When discarding batteries, environmental problems must be considered and local rules or laws governing the disposal of these batteries must be followed strictly.
- Do not expose this apparatus to rain, moisture, dripping or splashing and that no objects filled with liquids, such as vases, shall be placed on the apparatus.

ATTENTION

- Ne bloquez pas les orifices ou les trous de ventilation. (Si les orifices ou les trous de ventilation sont bloqués par un journal un tissu, etc., la chaleur peut ne pas être évacuée correctement de l'appareil.)
- Ne placez aucune source de flamme nue, telle qu'une bougie, sur l'appareil.
- Lors de la mise au rebut des piles, veuillez prendre en considération les problèmes de l'environnement et suivre strictement les règles et les lois locales sur la mise au rebut des piles.
- N'exposez pas cet appareil à la pluie, à l'humidité, à un égouttement ou à des éclaboussures et ne placez pas des objets remplis de liquide, tels qu'un vase, sur l'appareil.

Caution: Proper Ventilation

To avoid risk of electric shock and fire and to protect from damage, place the apparatus on a level surface. The minimal clearances are shown below:

Attention: Ventilation Correcte

Pour éviter les chocs électriques, les incendies et tout autre dégât, poser l'appareil sur une surface plate. Le dégagement minimum est indiqué ci-dessous:

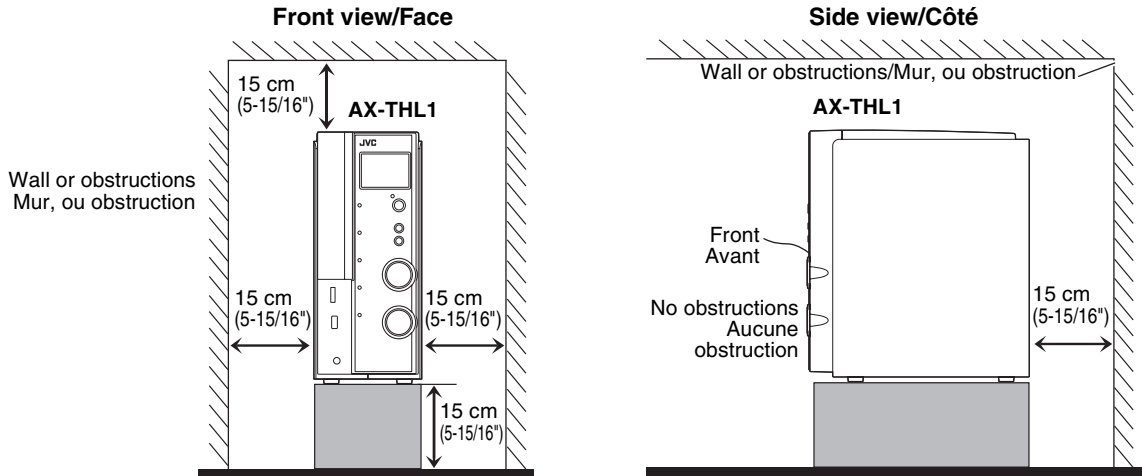

Table of contents

Introduction	2	Basic operations	16
Notes on handling	2	Turning the system on/off	16
Supplied accessories	2	Selecting the source to play	16
About files	3	Adjusting the volume [VOLUME]	17
Playable file types for the USB MEMORY	3	Listening with headphones (not supplied)	17
Index of parts and controls	4	Turning off the sound temporarily [MUTING]	17
Front panel (center unit)	4	Adjusting the brightness of the indications [DIMMER]	17
Rear panel (center unit)	5	Sleep Timer [SLEEP]	17
Remote control	6	Adjusting the output level of the speakers and subwoofer	18
Connections	7	Changing the scanning mode	18
Connecting the speakers and subwoofer	7	Operations for iPod	19
Speaker layout	8	Playing an iPod	19
Connecting a TV	9	Operations for USB MEMORY	21
Connecting the video components for the source of VIDEO 1.....	10	Basic operations for USB MEMORY	21
Connecting the video components for the source of VIDEO 2.....	11	Advanced operations for USB MEMORY	24
Connecting the video components for the source of VIDEO 3.....	12	Operations for surround mode	27
Connecting a USB mass storage class device	13	Using the surround mode	27
Connecting the iPod.....	13	Setting preferences	29
Connecting the power cord	13	Using the setup menus	29
Operating the TV and DVD player	14	Menu description	29
Operating the TV	14	Setting the audio terminal	31
Operating the DVD player	15	References	32
		Troubleshooting	32
		Specifications	33

Introduction

Notes on handling

■ Important cautions

Installation of the system

- Select a place which is level, dry and neither too hot nor too cold; between 5°C and 35°C (41°F and 95°F).
- Leave sufficient distance between the system and the TV.
- Do not use the system in a place subject to vibration.

Power cord

- Do not handle the power cord with wet hands.
- A small amount of power is always consumed while the power cord is connected to the wall outlet.
- Do not pull on the power cord to unplug the cord. When unplugging the cord, always grasp and pull the plug so as not to damage the cord.

To prevent malfunctions of the system

- There are no user-serviceable parts inside. If anything goes wrong, unplug the power cord and consult your dealer.
- Do not insert any metallic object into the system.

Note about copyright laws

Check the copyright laws in your country before recording from original sources. Recording of copyrighted material may infringe copyright laws.

■ Safety precautions

Avoid moisture, water and dust

Do not place the system in moist or dusty places.

Avoid high temperatures

Do not expose the system to direct sunlight and do not place it near a heating device.

When you are away

When away on travel or for other reasons for an extended period of time, disconnect the power cord plug from the wall outlet.

Do not block the vents

Blocking the vents may damage the system.

Care of the cabinet

- Stains on the system should be wiped off with a soft cloth. If the system is heavily stained, wipe it with a cloth soaked in water diluted neutral detergent and wrung well, then wipe clean with a dry cloth.
- Since the system may deteriorate in quality, become damaged or get its paint peeled off, be careful about the following.
 - DO NOT wipe it forcefully.
 - DO NOT wipe it with thinner, benzene or other organic solvents including disinfectants.
 - DO NOT apply any volatile substance such as insecticides to it.
 - DO NOT allow any rubber or plastic to remain in contact with it for a long time.

If water gets inside the system

Turn the system off and disconnect the power cord plug from the wall outlet, then call the store where you made your purchase. Using the system in this condition may cause a fire or electrical shock.

Supplied accessories

Check to be sure you have all of the supplied accessories. The number in parentheses is the quantity of the pieces supplied.

If anything is missing, contact your dealer immediately.

- Remote control (1)
- Batteries (2)
- Composite Video cord (1)
- Connection cable for iPod (1)
- Stand for iPod (1)

-
- This product incorporates copyright protection technology that is protected by U.S. patents and other intellectual property rights. Use of this copyright protection technology must be authorized by Macrovision, and is intended for home and other limited viewing uses only unless otherwise authorized by Macrovision. Reverse engineering or disassembly is prohibited.
 - iPod is a trademark of Apple Inc., registered in the U.S. and other countries.

- USE OF THIS PRODUCT IN ANY MANNER THAT COMPLIES WITH THE MPEG-4 VISUAL STANDARD IS PROHIBITED, EXCEPT FOR USE BY A CONSUMER ENGAGING IN PERSONAL AND NON-COMMERCIAL ACTIVITIES.
- Microsoft and Windows Media are either registered trademarks or trademarks of Microsoft Corporation in the United States and/or other countries.
- HDMI, the HDMI logo and High-Definition Multimedia Interface are trademarks or registered trademarks of HDMI licensing LLC.
- HDCP is the abbreviation of "High-Bandwidth Digital Content Protection," and is the high-reliable copy control technology licensed by Digital Content Protection, LLC.

Playable file types for the USB MEMORY

For all playable files

- The system can only recognize and play files with one of the following extensions, regardless of the letter case—upper/lower:
MP3: <.MP3>, <.mp3>
WMA: <.WMA>, <.wma>
WAV: <.WAV>, <.WAVE>, <.wav>, <.wave>
JPEG: <.JPG>, <.JPEG>, <.jpg>, <.jpeg>
MPEG-1/MPEG-2: <.MPG>, <.MPEG>, <.mpg>, <.mpeg>
ASF: <.ASF>, <.asf>
- The system recognizes up to 150 tracks (files) per group, 99 groups per device, and the total number of the tracks (files) that the system can play is 4 000.
- Some files may not be played back normally because of their characteristics or recording conditions.
- Some files require a longer readout time. (It differs due to the complexity of the directory/file configuration.)
- If different kinds of files are mixed, set the FILE TYPE setting in the PICTURE menu to the appropriate setting for the data to be read (“AUDIO”, “STILL PICTURE” or “VIDEO”). (See page 30.)

For MP3/WMA/WAV files

- The system supports MP3/WMA files recorded at a bit rate of 32 – 320 kbps and a sampling frequency of 16 kHz, 22.05 kHz, 24 kHz (for WMA only), 32 kHz, 44.1 kHz, or 48 kHz.
- If the track information (album name, artist, and track title, etc.) is recorded, it appears in the file control display on the TV screen. (See page 24.)
- It is recommended that you make each MP3/WMA/WAV files at the following conditions:
MP3/WMA: At a sample rate of 44.1 kHz and bit rate of 128 kbps.
WAV: 44.1 kHz/16 bit Linear PCM.

For JPEG files

- It is recommended that you record a file at 640 x 480 resolution. (If a file has been recorded at a resolution of more than 640 x 480, it will take a longer time to be displayed.)
- This system can only play baseline JPEG files.

For MPEG-1/MPEG-2 files

- The stream format should conform to MPEG system/program stream.
- 720 x 576 pixels (25 fps)/720 x 480 pixels (30 fps) is recommended for the highest resolution.
- This system also supports the resolutions of 352 x 576/480 x 576/352 x 288 pixels (25 fps) and 352 x 480/480 x 480/352 x 240 pixels (30 fps).
- The file format should be MP@ML (Main Profile at Main Level)/SP@ML (Simple Profile at Main Level)/MP@LL (Main Profile at Low Level).
- Audio streams should conform to MPEG1 Audio Layer-2 or MPEG2 Audio Layer-2.

For ASF files

- The system supports the types of the advanced simple profile as MPEG-4 files (MPEG-4 ASF).
- The system supports MPEG-4 files with the following conditions:
File format: ASF
Visual profile: MPEG-4 SP (Simple Profile)
Audio CODEC: G.726
Max. picture size: 352 x 288 (CIF)
Max. bit rate: 384 kbps

Index of parts and controls

The numbers in the figures indicate the pages where the details of the parts are described.

Front panel (center unit)

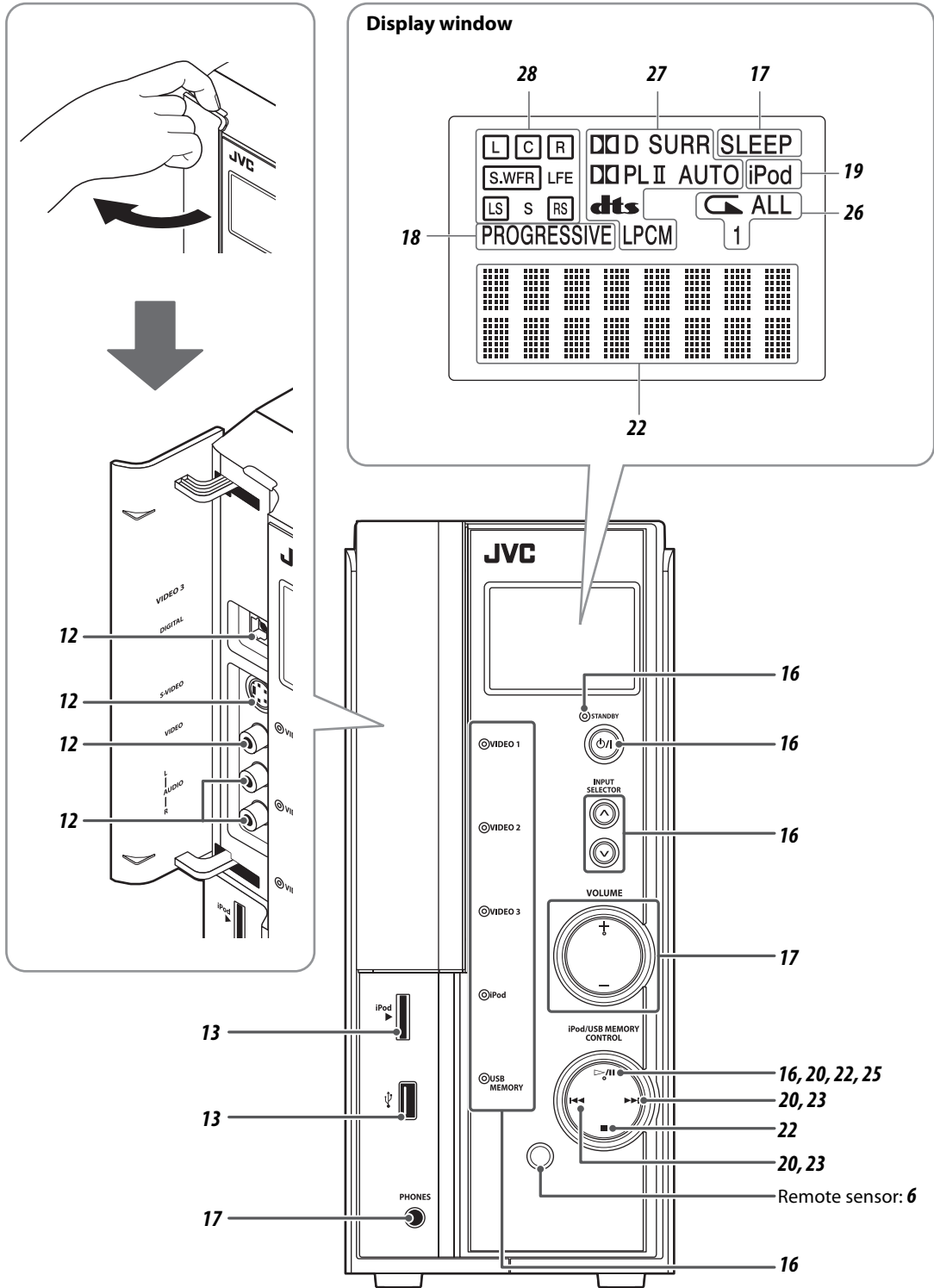

Rear panel (center unit)

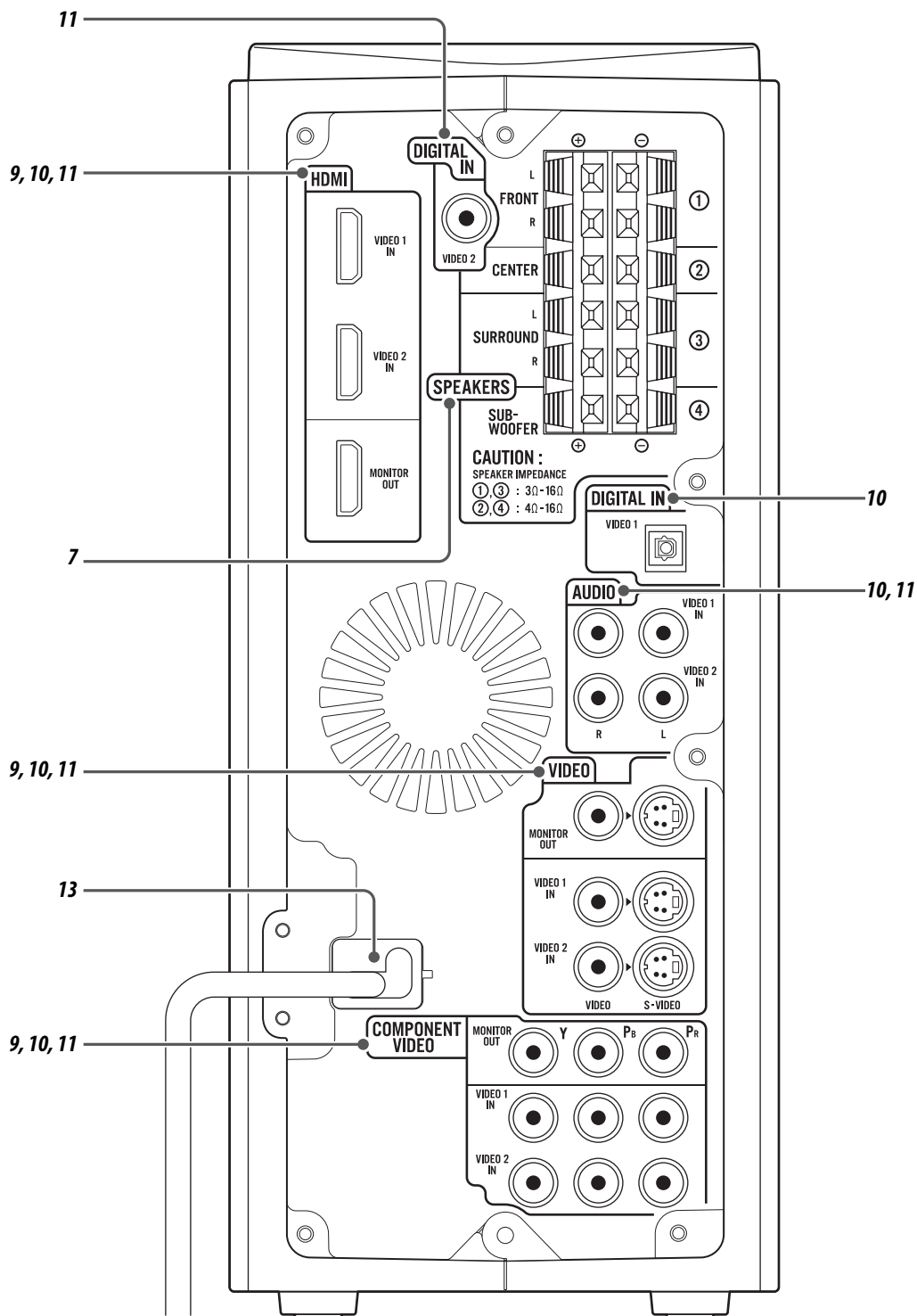

Remote control

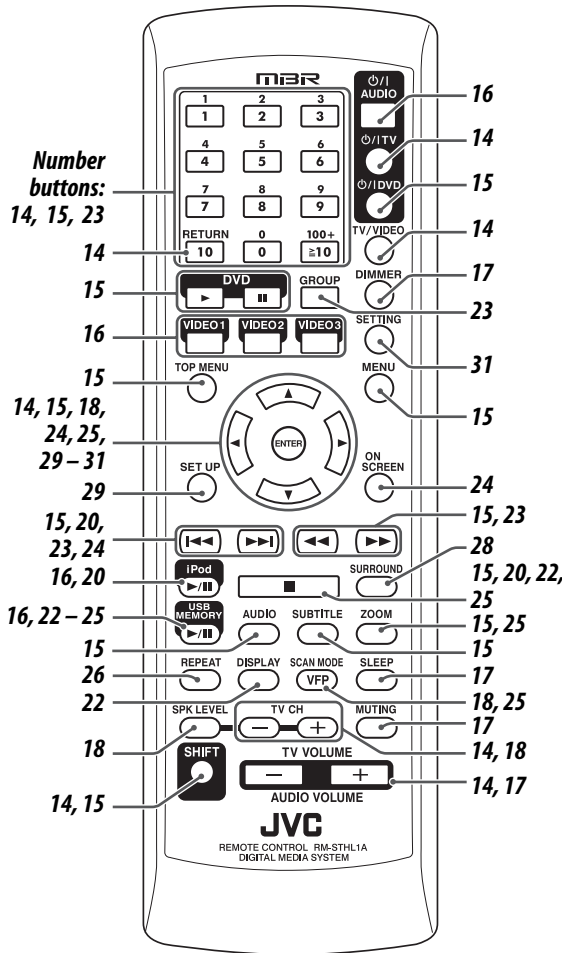

Number buttons: 14, 15, 23

14

15

16

15

14, 15, 18, 24, 25, 29-31

29

15, 20, 23, 24

16, 20

16, 22-25

15

26

22

18

14, 15

■ Putting batteries in the remote control

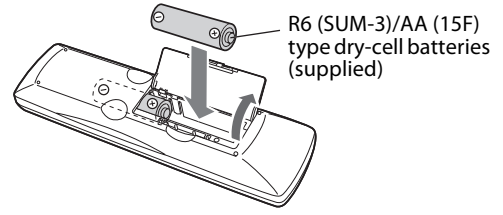

If the range or effectiveness of the remote control decreases, replace both batteries.

CAUTION

- Batteries shall not be exposed to excessive heat such as sunshine, fire or the like.

Operating the system from the remote control

Aim the remote control directly to the remote sensor of the center unit.

- If you operate it from a diagonal position, the operating range (approx. 5 m (16 ft)) may be shorter.
- Do not block the remote sensor.

Connecting the speakers and subwoofer

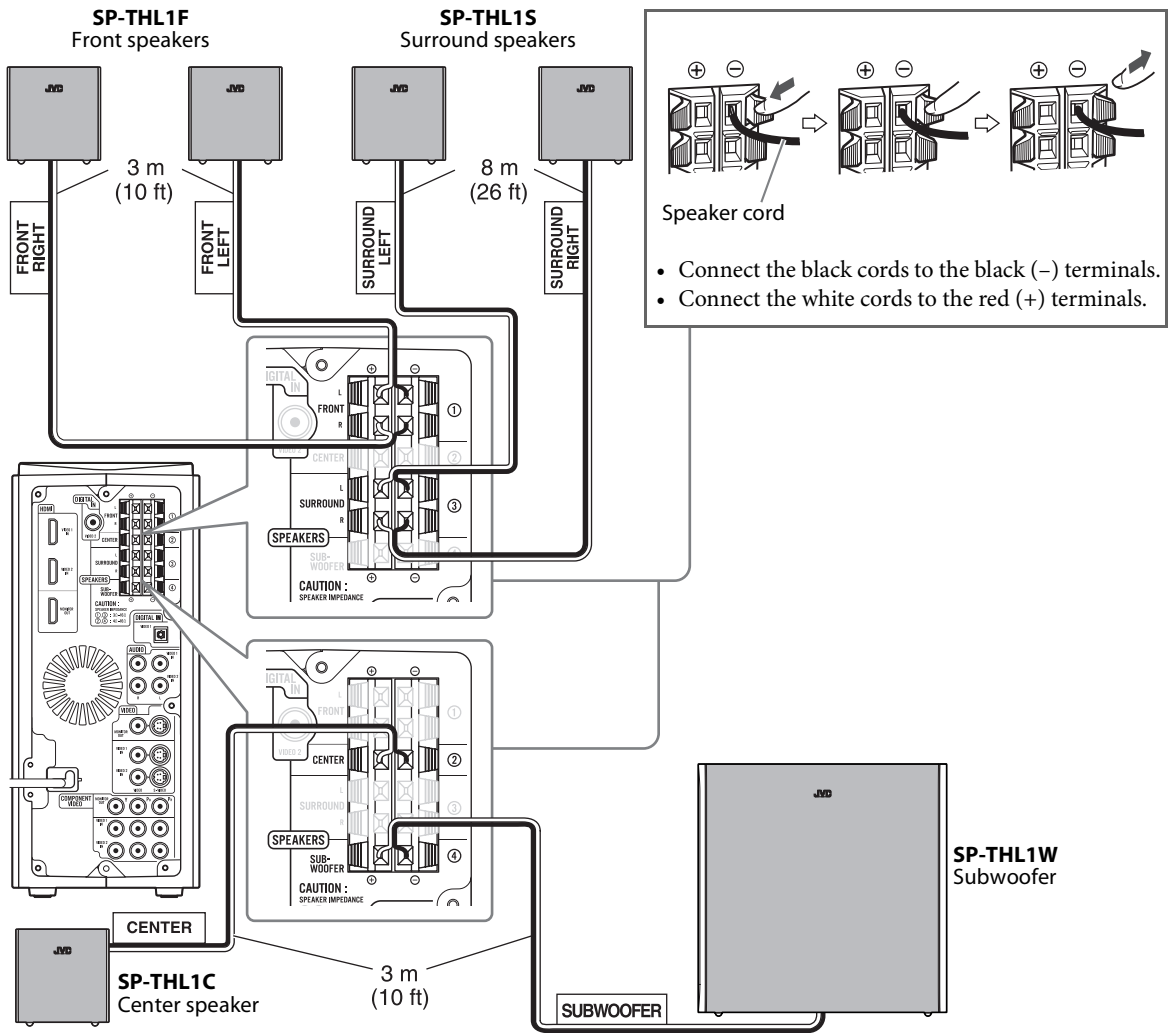

CAUTION

- If you connect speakers other than the supplied ones, use speakers of the same speaker impedance (SPEAKER IMPEDANCE) indicated on the rear of the center unit.
- DO NOT connect more than one speaker to one speaker terminal.
- When installing the satellite speakers on the wall;
 - Be sure to have them installed on the wall by qualified personnel.
 - DO NOT install the satellite speakers on the wall by yourself to avoid unexpected damage from falling off the wall due to incorrect installation or weakness in wall structure.
 - Care must be taken in selecting a location for speaker installation on a wall. Injury to personnel or damage to equipment may result if the speakers installed interfere with daily activities.

Precautions for daily use

- When moving the speakers, do not pull the speaker cords; otherwise, the speakers may fall over, causing damage or injury.
- Do not reproduce sounds at so high a volume that the sound is distorted; otherwise, the speakers may be damaged by internal heat buildup.

Speaker layout

To obtain the best possible sound from this system, you need to place all the speakers except the subwoofer at the same distance from the listening position.

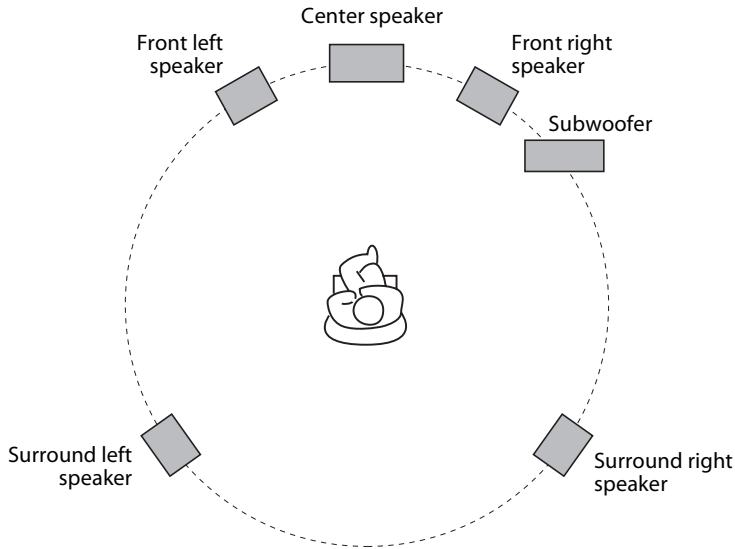

If your speakers cannot be placed at the same distance from the listening position
You can adjust the delay time of the speakers. See “Delay menu (DELAY)” on page 30.

NOTE

- Place the satellite speakers on a flat and level surface.
- The subwoofer, front and center speakers are magnetically shielded to avoid color distortions on TVs. However, if not installed properly, they may cause color distortions. So, pay attention to the following when installing the speakers.
 - When placing the speakers near a TV set, turn off the TV’s main power switch or unplug it before installing the speakers. Then wait at least 30 minutes before turning on the TV’s main power switch again.Some TVs may still be affected even though you have followed the above. If this happens, move the speakers away from the TV.
- The surround speakers are not magnetically shielded. If they are located nearby the TV or monitor, it will probably cause color distortion on the screen. To avoid this, do not place the speakers nearby the TV or monitor.

Connecting a TV

- You can get better picture quality in the order — HDMI > Component video > S-video > Composite video.
- Distortion of picture may occur when connecting the TV via a VCR, or to a TV with a built-in VCR.
- You need to set “MONITOR TYPE” in the PICTURE menu correctly according to the aspect ratio of your TV. (See page 29.)
- If your TV supports progressive video input, you can enjoy a high quality picture from the source of “USB MEMORY” by setting the progressive scan mode to active and connect your TV with the HDMI cord or component video cord. (See page 18.)
- You can use below terminals for each sources to see the picture on the TV.

Terminal	Source	VIDEO 1 VIDEO 2	VIDEO 3	iPod	USB MEMORY
HDMI		√	—	—	—
COMPONENT VIDEO		√	—	—	√
S-VIDEO		√	√	√	√
VIDEO		√	√	√	√

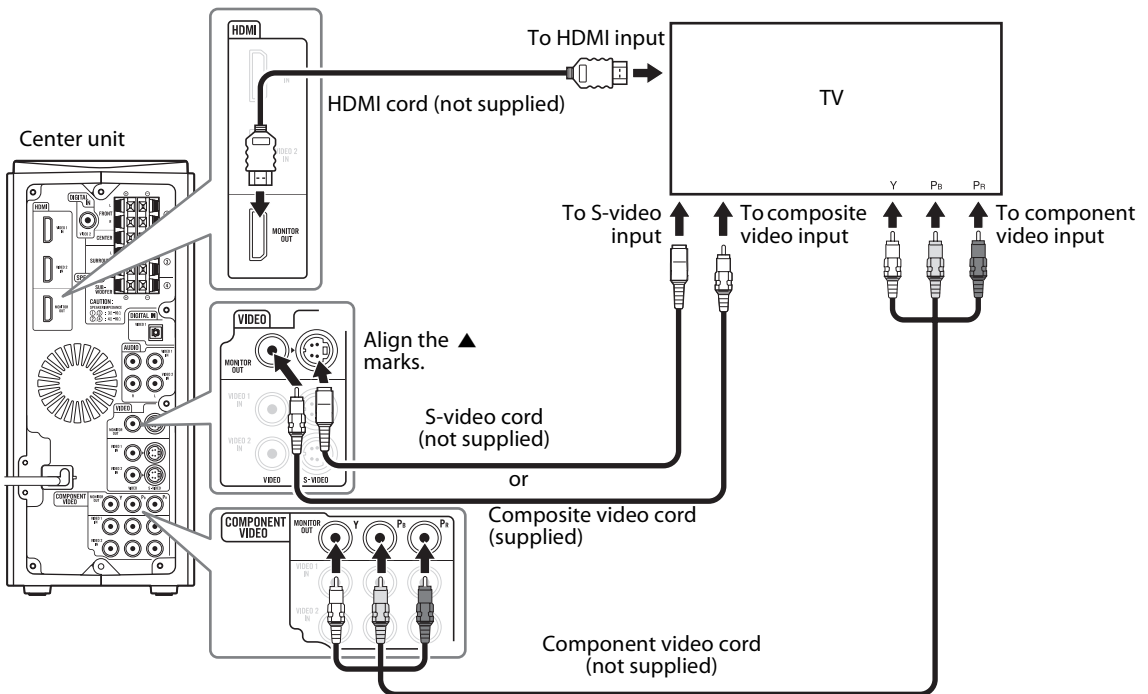

NOTE

- HDMI MONITOR OUT terminal passes through the signal from the HDMI input terminal (VIDEO 1 and VIDEO 2) selected as the source.
- COMPONENT MONITOR OUT terminal passes through the signal from the COMPONENT input terminal (VIDEO 1 and VIDEO 2) selected as the source.
- S-VIDEO MONITOR OUT terminal passes through the signal from the S-VIDEO input terminal (VIDEO 1, VIDEO 2 and VIDEO 3) selected as the source.
- VIDEO MONITOR OUT terminal passes through the signal from the VIDEO input terminal (VIDEO 1, VIDEO 2 and VIDEO 3) selected as the source.
- Use an HDMI cable shorter than 5 m (15 ft).
- When you are playing HDCP (High-Bandwidth Digital Content Protection) content, the sound and picture may not be transmitted to the speakers and TV for a few seconds at the beginning due to the confirmation process.
- If the component video input jacks of your TV are of the BNC type, use a plug adapter (not supplied) to convert the pin plugs to BNC plugs.

Connecting the video components for the source of VIDEO 1

■ To connect the video components for the source of VIDEO 1

- You can get better picture quality in the order — HDMI > Component video > S-video > Composite video.

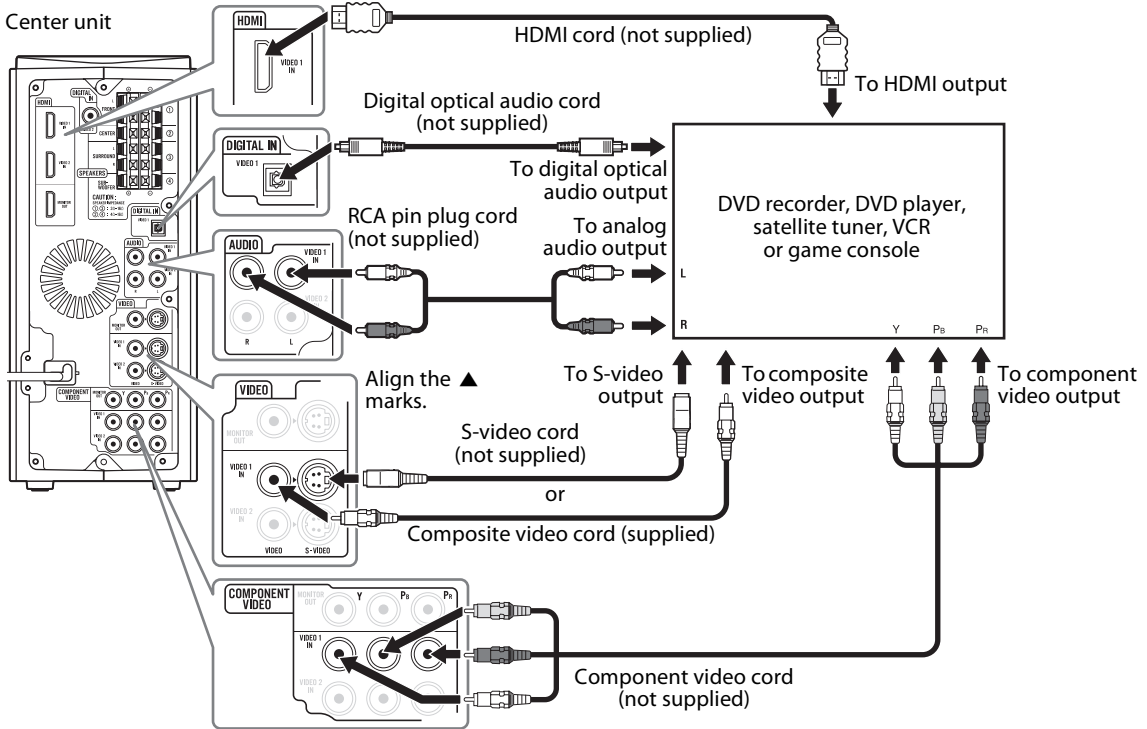

NOTE

- Unify the way of TV connection and that of video component's (for example, connect a video component through S-VIDEO jack when TV is connected through S-VIDEO jack). Otherwise, the signal from the component is not sent to the TV.
- The audio signal through the HDMI VIDEO 1 IN terminal is not reproduced on this system. The signal is reproduced on the TV connected with HDMI MONITOR OUT terminal.
- Use an HDMI cable shorter than 5 m (15 ft).
- When you are playing HDCP (High-Bandwidth Digital Content Protection) content, the sound and picture may not be transmitted to the speakers and TV for a few seconds at the beginning due to the confirmation process.
- If the component video output jacks of your video components of the BNC type, use a plug adapter (not supplied) to convert the pin plugs to BNC plugs.
- When shipped from the factory, the source of "VIDEO 1" have been set for use with the AUDIO VIDEO 1 IN terminal for the audio connection. If you connect the components with digital optical audio cord, change the audio input (VIDEO 1) setting to "Digital." (See page 31.)
- Before connecting a digital optical cable, unplug the protective plug from DIGITAL IN VIDEO 1 terminal.
- If you connect a sound-enhancing device such as a graphic equalizer between the source components and this system, the sound output through this system may be distorted.

Connecting the video components for the source of VIDEO 2

■ To connect the video components for the source of VIDEO 2

- You can get better picture quality in the order — HDMI > Component video > S-video > Composite video.

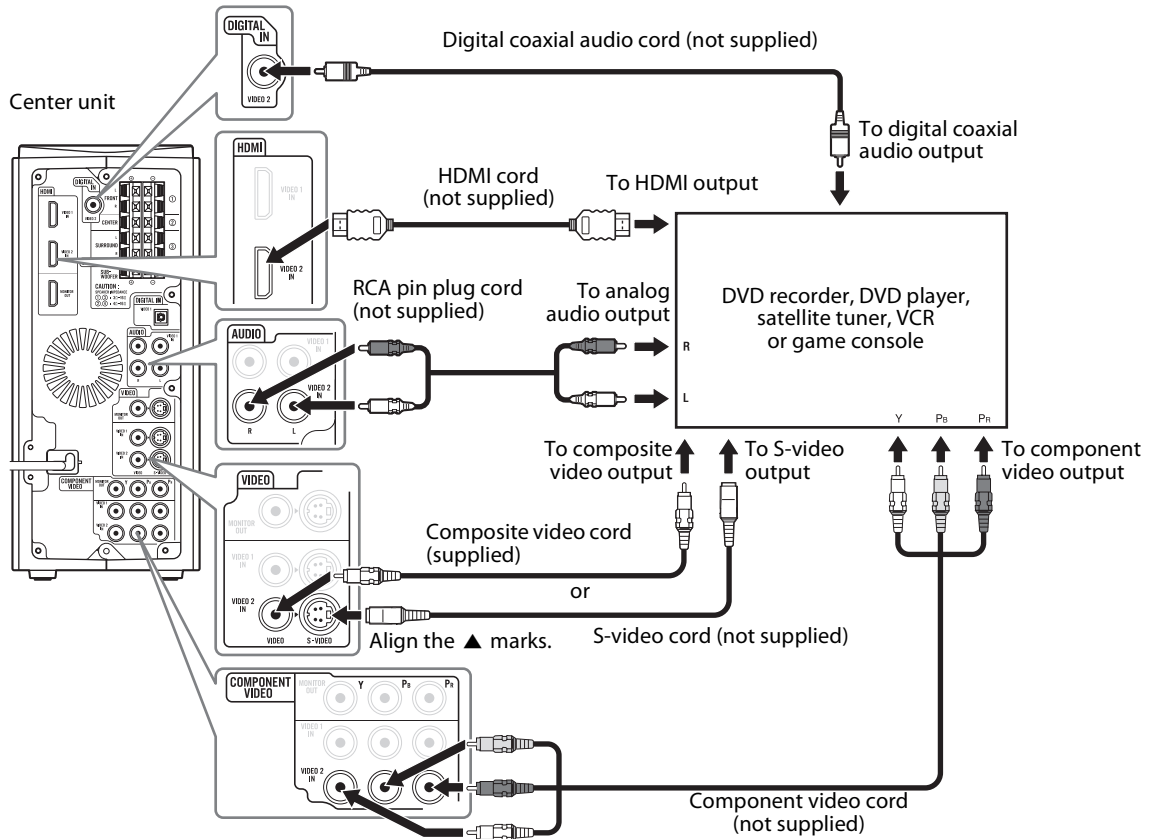

NOTE

- Unify the way of TV connection and that of video component's (for example, connect a video component through S-VIDEO jack when TV is connected through S-VIDEO jack). Otherwise, the signal from the component is not sent to the TV.
- The audio signal through the HDMI VIDEO 2 IN terminal is not reproduced on this system. The signal is reproduced on the TV connected with HDMI MONITOR OUT terminal.
- Use an HDMI cable shorter than 5 m (15 ft).
- When you are playing HDCP (High-Bandwidth Digital Content Protection) content, the sound and picture may not be transmitted to the speakers and TV for a few seconds at the beginning due to the confirmation process.
- If the component video output jacks of your video components of the BNC type, use a plug adapter (not supplied) to convert the pin plugs to BNC plugs.
- When shipped from the factory, the source of "VIDEO 2" have been set for use with the AUDIO VIDEO 2 IN terminal for the audio connection. If you connect the components with digital coaxial audio cord, change the audio input (VIDEO 2) setting to "Digital." (See page 31.)
- If you connect a sound-enhancing device such as a graphic equalizer between the source components and this system, the sound output through this system may be distorted.

Connecting the video components for the source of VIDEO 3

■ To connect the video components for the source of VIDEO 3

- You can get better picture quality in the order — S-video > Composite video.

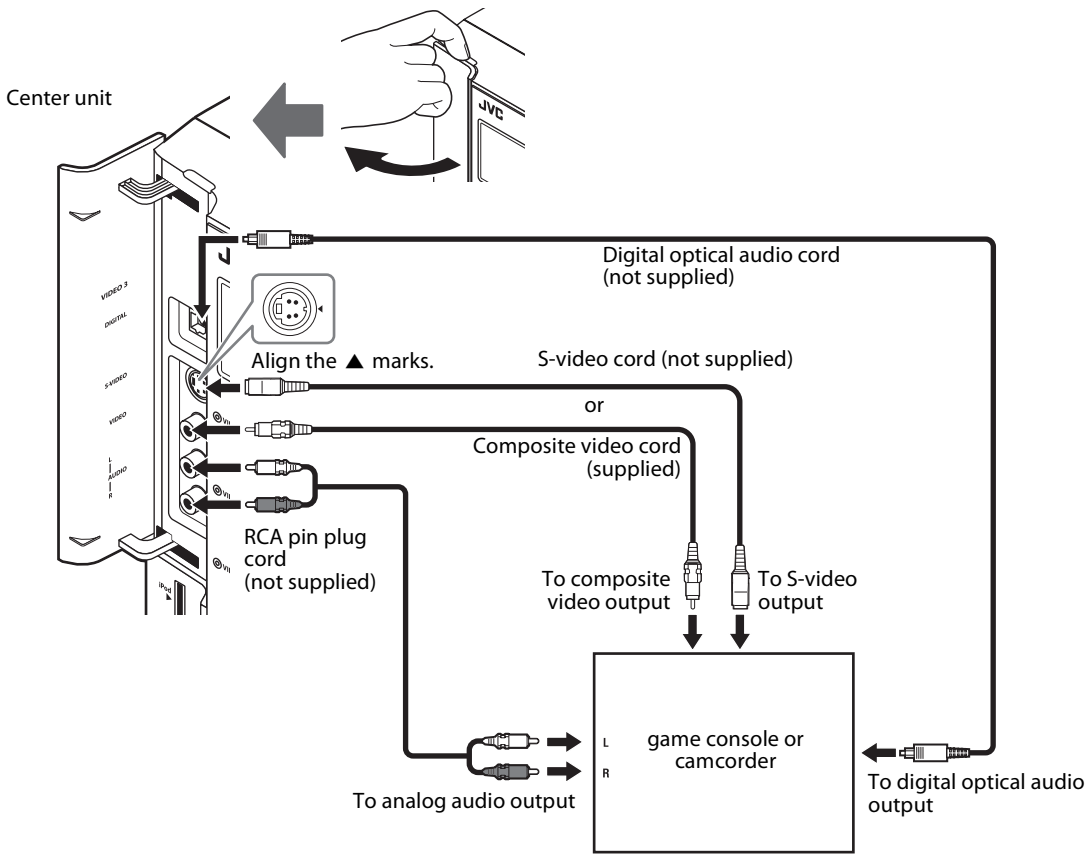

NOTE

- Unify the way of TV connection and that of video component's (for example, connect a video component through S-VIDEO jack when TV is connected through S-VIDEO jack). Otherwise, the signal from the component is not sent to the TV.
- When playback from USB source, scan mode can be adjusted to have better picture quality. (See page 18.)
- If you connect a sound-enhancing device such as a graphic equalizer between the source components and this system, the sound output through this system may be distorted.
- When shipped from the factory, the source of "VIDEO 3" have been set for use with the VIDEO 3 AUDIO L/R audio terminal for the audio connection. If you connect the components with digital optical audio cord, change the audio input (VIDEO 3) setting to "Digital." (See page 31.)

Connecting a USB mass storage class device

You can connect a USB mass storage class device such as a USB flash memory device, hard disk drive, multimedia card reader, digital camera, etc. to this system.

- After connecting a USB mass storage class device to this system and selecting USB MEMORY as the source, the file control display appears on the TV screen. (See page 24.)

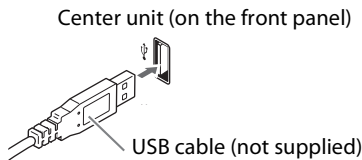

NOTE

- Connect one USB mass storage class device to the system at a time. Do not use a USB hub.
- While playing back a file in a USB mass storage class device, do not disconnect the device. It may cause a malfunction of both the system and the device.
- JVC bears no responsibility for any loss of data in the USB mass storage class device while using this system.
- When connecting with a USB cable, use a cable less than 1 m (3.3 ft) in length.
- This system is compatible with USB 2.0 Full Speed.
- You can play back the following types of files in a USB mass storage class device (maximum data transfer rate: 2 Mbps):
 - Music: MP3, WMA, WAV
 - Picture: JPEG
 - Movie: MPEG-1, MPEG-2, ASF
- To view a picture/movie files in a USB mass storage class device on the TV, connect the system to the TV via the composite, S-video or component jacks. (See page 9.)
- You cannot play back a file larger than 2 GB.
- When playing a file which has a large transfer rate, frames or sounds may be dropped during playback.
- This system cannot recognize a USB mass storage class device whose rating exceeds 5 V/500 mA.
- This system may not recognize some USB mass storage class devices and does not support DRM (Digital Rights Management).
- This system may not play back some files even though their formats are listed above.
- The battery of a USB mass storage class device is charged while “USB MEMORY” is selected as the source.
- You cannot connect a computer to the (USB MEMORY) terminal of the system.
- When connecting a USB mass storage device, refer also to its manual.
- An iPod does not play on the USB MEMORY terminal.

Connecting the iPod

Center unit (on the front panel)

Turn the arrow-mark side left when connecting the plug.

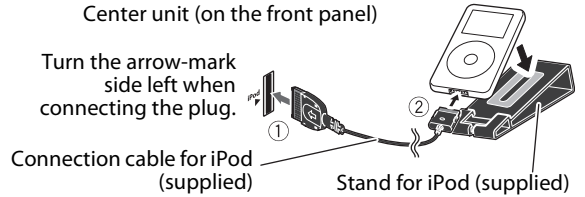

CAUTION

- Be sure to reduce the volume on the system to the minimum level before connecting an iPod. Adjust the volume after playback has started.
- DO NOT connect or disconnect the iPod when the system is turned on.

NOTE

- To disconnect the connection cable from the iPod, hold the buttons on the sides of the plug then pull it out.
- You cannot send any data to your iPod from the system.
- Do not carry the System with iPod connected. You might drop it or it might cause damages to the connector part.
- Do not touch or hit the iPod terminal pins or connector pins directly. It might cause damages to the connector part.
- “iPod” indicator lights up during iPod connectivity.
- To view a video/picture from the iPod on the TV, connect the system to the TV via the composite or S-video jacks. (See page 9.)
- iPod does not correspond to the component video output.

Connecting the power cord

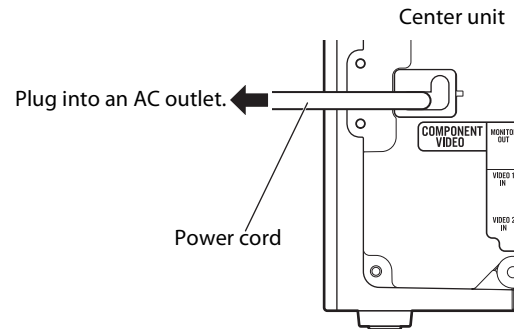

CAUTION

- Disconnect the power cord before cleaning or moving the system.
- Do not pull on the power cord to unplug the cord. When unplugging the cord, always grasp and pull the plug so as not to damage the cord.

NOTE

- If the wall outlet does not match the AC plug, use an AC plug adapter (not supplied).

Operating the TV and DVD player

You can use the remote control to operate not only this unit but also JVC and other manufacturers' TV and DVD player.

- Refer also to the manuals supplied for the TV and DVD player.
- To operate the equipment, aim the remote control directly at the remote sensor on the target equipment.

The buttons described below are used on pages 14 to 15.

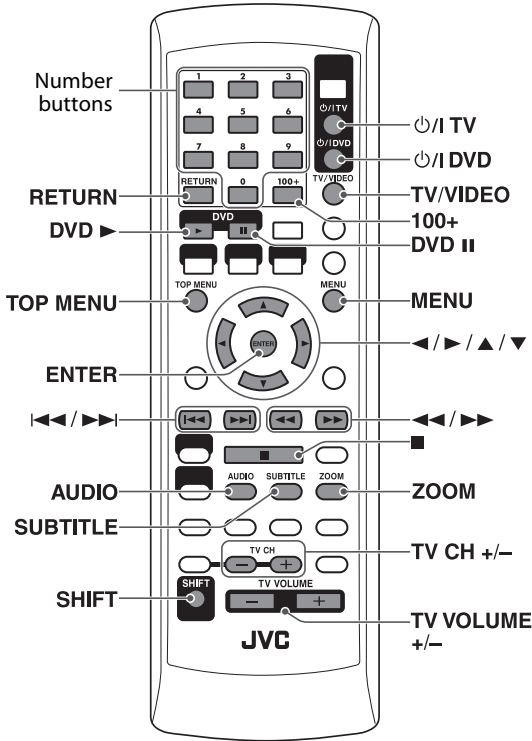

3 Press number buttons (1 - 9, 0) to enter the manufacturer's code (2 digits).

Examples:

For a AKAI TV: Press 0, then 2.

For a FISHER TV: Press 1, then 7.

* 01 is the initial setting.

JVC	01*	PHILIPS	29
AKAI	02, 17	PIONEER	42
DAEWOO	08, 09, 29	SABA	35, 36, 37, 62, 63, 64
FISHER	17	SAMSUNG	29, 51, 52, 71, 72, 73, 74
HITACHI	24, 26	SANYO	17
IRRADIO	17	SCHNEIDER	17
MAGNAVOX	29	SHARP	54
MARANTZ	30	SONY	55
MITSUBISHI	30	TOSHIBA	53
ORION	38	ZENITH	69, 70
PANASONIC	39, 41		

4 Release TV/VIDEO .

If there is more than one code listed for corresponding brand, try each one until you enter the correct one.

NOTE

- Manufacturers' codes are subject to change without notice.

Operating the TV

■ To set the manufacturer's code

1 Press and hold TV/VIDEO .

Press and hold the button until step 3 is finished.

2 Press ENTER.

■ To operate a TV

You can perform the following operations on the TV.

TV/VIDEO	Turn on or off the TV.
TV/VIDEO	Set the input mode (either TV or VIDEO).
1 - 9, 0, or +100 while pressing SHIFT	Selects the channels.
RETURN while pressing SHIFT	Alternates between the previously selected channel and the current channel.
TV CH +/- while pressing SHIFT	Change the channels.
TV VOLUME +/- while pressing SHIFT	Adjust the volume.

NOTE

- The operating buttons may differ depending on manufacturers.

Operating the DVD player

■ To set the manufacturer's code

1 Press and hold  DVD.
Press and hold the button until step 3 is finished.

2 Press ENTER.

3 Press number buttons (1 - 9, 0) to enter the manufacturer's code (2 digits).

Examples:

For a MAGNAVOX DVD player: Press 0, then 5.

For a PANASONIC DVD player: Press 1, then 0.

* 01 is the initial setting.

JVC	01*	PIIONEER	11
KENWOOD	03, 04	PROSCAN	12
MAGNAVOX	05	RCA	12
MARANTZ	06	SAMSUNG	13
MITSUBISHI	07	SONY	14
ONKYO	08, 09	TOSHIBA	05
PANASONIC	10	YAMAHA	15
PHILIPS	06	ZENITH	05, 16

4 Release  DVD.

If there is more than one code listed for corresponding brand, try each one until you enter the correct one.

■ To operate a DVD player

You can perform the following operations on the DVD player.

 DVD	Turn on or off the DVD player.
DVD ►	Play back a disc.
DVD II	Pause playback. To release it, press DVD ►.
1 - 9, 0 while pressing SHIFT	Select a desired chapter number.
TOP MENU	Display a DVD top menu.
MENU	Display a DVD menu.
◀ / ▶ / ▲ / ▼	Select a DVD menu item.
ENTER	Enter a DVD menu item.
◀◀ / ▶▶	Skip to the beginning of next chapter / return to the beginning of current (or previous) chapter.
◀◀ / ▶▶	Fast-forward/fast-reverse search.
■	Stop playback.
AUDIO	Select the audio language/ audio channel.
SUBTITLE	Select the subtitle language.
ZOOM	Enlarge the picture.

NOTE

- The operating buttons may differ depending on manufacturers.

Basic operations

The buttons on the remote control are used to explain most of the operations in this manual. You can use the buttons on the center unit if they have the same name or marks as on the remote control, unless otherwise noted.

- The icon such as  shows the file types the operation is available for.

The buttons described below are used on pages 16 to 18.

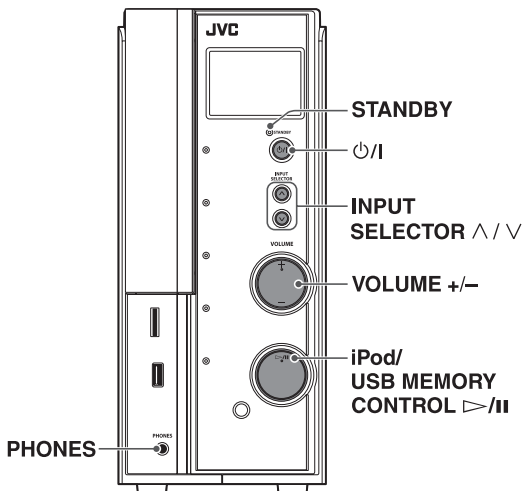
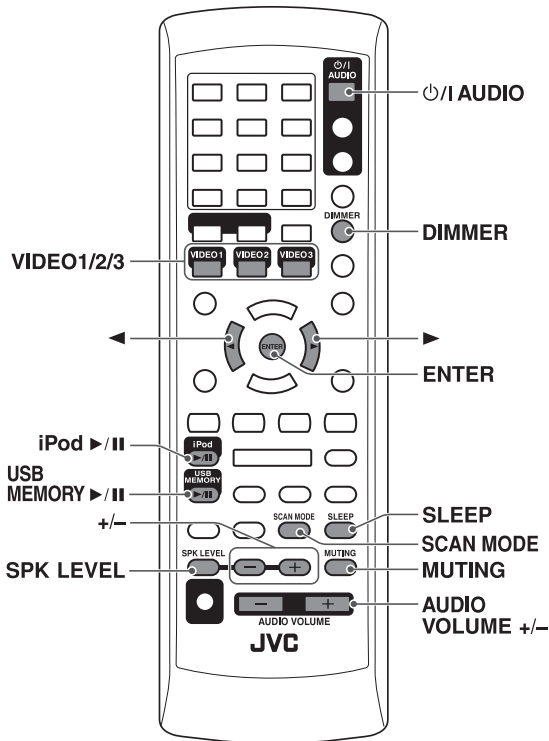

Turning the system on/off

On the remote control:
Press  **AUDIO**.

On the center unit:
Press .

NOTE

- A small amount of power is consumed even when the power is turned off. This is called standby mode and the STANDBY lamp lights in this mode. Unplug the power cord from the AC outlet to turn the power off completely.
- You can also turn on the system by pressing the following buttons;
 - One of the source selecting buttons on the remote control (VIDEO1, VIDEO2, VIDEO3, iPod >/|| and USB MEMORY >/||)
 - iPod/USB MEMORY CONTROL >/|| on the center unit. (Turning on by the button automatically changes the source to USB MEMORY except when the last source was iPod.)

Selecting the source to play

On the remote control:
Press one of the source selecting buttons (VIDEO1 - 3, USB MEMORY >/||, or iPod >/||).

USB MEMORY >/||: To play back a file in a USB mass storage class device. (See page 21.)

iPod >/||: To start play back a connected iPod. (See page 19.)

VIDEO1 - 3: To select the external components connected to the VIDEO 1 - 3 terminals on the center unit. (See page 10 to 12.)

On the center unit:

Press **INPUT SELECTOR ^ / v** repeatedly until the source name you want appears on the display window.

NOTE

- The source selection lamp of the selected source lights up on the center unit.
- It may take time to change the source.

Adjusting the volume [VOLUME]

CAUTION

- Always set the volume to minimum level before starting any source. If the volume is set at a high level, the sudden blast of sound may damage your hearing and/or blow out the speakers.

On the remote control:

Press **AUDIO VOLUME +/-**.

On the center unit:

Press **VOLUME +/-**.

Listening with headphones (not supplied)

CAUTION

Be sure to turn down the volume;

- Before connecting or putting on headphones as high volume may damage both the headphones and your hearing.
- Before disconnecting headphones as high volume may suddenly come out of the speakers.

While connecting a pair of headphones to the PHONES jack on the center unit, the system automatically cancels the surround mode (see page 27) currently selected, deactivates the speakers, and activates the headphone mode. "HEAD PHONE" appears on the display window.

Headphone mode

When using the headphones, the following signals come out regardless of your speaker setting;

- For 2 channel sources, the front left and right channel signals are come out from the headphones.
- Multi-channel signals are downmixed and come out from the headphones.

Turning off the sound temporarily [MUTING]

Press MUTING.

To restore the sound

Perform one of the following:

- Press MUTING again.
- Press AUDIO VOLUME +/-.
- Press VOLUME +/- on the center unit.

Adjusting the brightness of the indications [DIMMER]

Press DIMMER.

Each time you press the button, you can change the brightness level in 3 steps.

Sleep Timer [SLEEP]

The system turns off automatically when the specified period of time has passed.

Press SLEEP repeatedly.

Each time you press the button, the shut-off time changes as follows:

10 → 20 → 30 → 60 → 90 → 120 → 150 → 180 →
 -- (Canceled) → (back to the beginning)

- The SLEEP indicator lights up on the display.

Example:

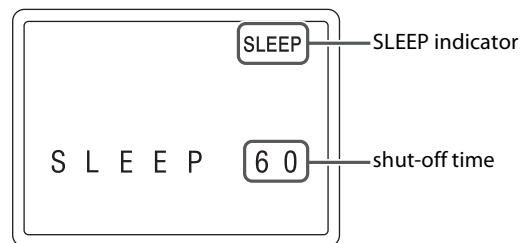

To check the remaining time

Press SLEEP once.

To change the remaining time

Press SLEEP repeatedly.

To cancel

Press SLEEP repeatedly, until "SLEEP --" appears.

- The SLEEP indicator goes off.
- Turning off the power also cancels the Sleep Timer.

Adjusting the output level of the speakers and subwoofer

1 Press SPK LEVEL to show the target speaker indication on the display window.

Each time you press the button, the indication of the speakers changes as follows:

FRNT L (Front left speaker) ➔ FRNT R (Front right speaker) ➔ CENTER (Center speaker) ➔ SURR L (Surround left speaker) ➔ SURR R (Surround right speaker) ➔ SUBWFR (Subwoofer) ➔ (back to the beginning)

2 Press +/- to adjust the output level from -6 to +6 while speaker indication is displayed.

NOTE

- You can also make adjustments by using the setup menu shown on the TV screen. (See page 30.)
- The adjustments take effect for all sources.

Changing the scanning mode

The system can be accommodated to your TV's scanning mode when playing back a JPEG/MPEG-1/MPEG-2/ASF file in the USB mass storage class device.



NOTE

- To use the system in the progressive mode, it is required that the center unit is connected to the TV by using component video cord (not supplied). (See page 9.)

■ While USB MEMORY playback is stopped

1 Press and hold SCAN MODE for 2 seconds.

The current setting appears on the display window.

2 Press ◀/▶ to select the desired mode.

- **INT-LACE:** Select when your TV supports the interlaced scanning mode only.
- **PROGRESS:** Select when your TV equipped with component jacks terminal supports the progressive scanning mode.

You can get better picture quality in PROGRESS mode than in INT-LACE mode.

3 Press ENTER while the selected mode is displayed.

When "PROGRESS" is selected, the PROGRESSIVE indicator lights on the display window.

NOTE

- Although the picture may be distorted when you press ENTER, this is not a malfunction of the system.

- There are some progressive TVs and High-Definition TVs that are not fully compatible with this system, resulting in an unnatural picture when playing back a JPEG/MPEG-1/MPEG-2/ASF file in the progressive scanning mode. In such a case, change the scanning mode to "INT-LACE."
- All JVC progressive TVs and High-Definition TVs are fully compatible with this system.

Operations for iPod

The buttons described below are used on page 20.

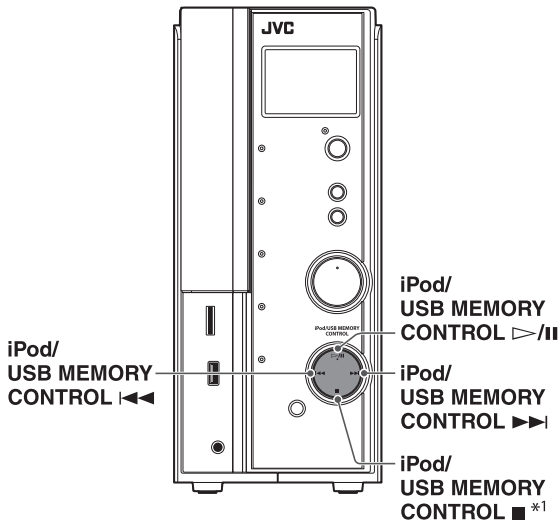
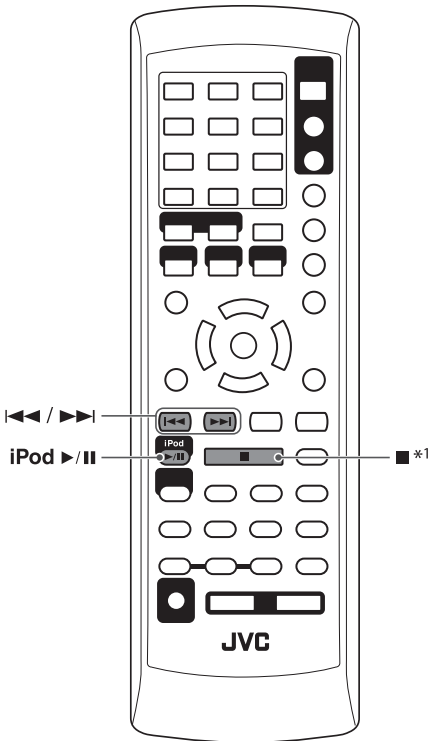

*1 This button does not function as a stop button to operate an iPod. This button functions only to turn ON/OFF the charge mode to operate an iPod.

Playing an iPod

CAUTION

- Before selecting the video source to play, make the appropriate setting for video output on the iPod.

Compatible iPod types:

iPod model	AUDIO	VIDEO
iPod nano 1GB/2GB/4GB	√	
iPod nano (2nd Generation) 2GB/4GB/8GB	√	
iPod mini 4GB/6GB	√	
iPod (4th Generation) 20GB/40GB	√	
iPod photo (4th Generation) 20GB/30GB/40GB/60GB	√	√*2
iPod video (5th Generation) 30GB/60GB/80GB	√	√

*2 Only for still picture.

- If the iPod does not play correctly, update your iPod Software to the latest version. For details about updating your iPod, check on the Apple web site <<http://www.apple.com>>.
- If incompatible iPod type is connected, the iPod may not be operated from the System. To enable the operation, before connecting the iPod, switch the charge mode to "CHARGE OFF" (refer to "To turn ON/OFF the charge mode" on page 20) with "iPod" selected as source.

NOTE

- Sound distortion may occur when playing back audio sources with high recording levels. When distortion occurs, it is recommended to turn off the equalizer of the iPod. For information on operating the iPod, see the iPod instruction manual.

To turn ON/OFF the charge mode

- While “iPod” is selected as a source

1 Display the current charge mode.

On the remote control:

Press and hold ■ for 2 seconds.

On the center unit:

Press and hold iPod/USB MEMORY CONTROL ■ for 2 seconds.

The current charge mode appears on the display window.

2 Select the desired charge mode.

On the remote control:

Press ■ repeatedly.

On the center unit:

Press iPod/USB MEMORY CONTROL ■ repeatedly.

- CHARGE ON: Select when you want to charge the iPod battery through the iPod terminal.
- CHARGE OFF: Select when you do not want to charge the iPod battery through the iPod terminal.

NOTE

- When the charge mode is “CHARGE ON” the iPod battery is charged through the iPod terminal while “iPod” is selected as a source.
- The initial setting of charge mode is “CHARGE ON” and it is advisable to set it to “CHARGE ON” for most of the time.

Starting playback

1 Connect an iPod (see page 13) while the system is turned off.

2 Turn on the system. (see page 16)

3 Select “iPod” as the source. (see page 16)

“iPod CONNECT” appears on the display. If an iPod is not connected firmly, “iPod NO CONNECT” appears.

- The iPod indicator lights up on the display.

4 Start playing on the iPod.

On the remote control:

Press iPod ▶/II.

On the center unit:

Press iPod/USB MEMORY CONTROL ▷/II.

Press above button again if iPod does not start playback.

To pause playback

On the remote control:

Press iPod ▶/II during playback.

On the center unit:

Press iPod/USB MEMORY CONTROL ▷/II during playback.

To continue playback, press the button again.

Fast-forward/fast-reverse search

On the remote control:

Press and hold |◀◀ or ▶▶| during playback.

On the center unit:

Press and hold iPod/USB MEMORY CONTROL |◀◀ or ▶▶| during playback.

To return to normal speed playback

Release the button.

Skip to the next/previous item

On the remote control:

Press |◀◀ or ▶▶|.

On the center unit:

Press iPod/USB MEMORY CONTROL |◀◀ or ▶▶|.

Turning off the iPod

On the remote control:

Press and hold iPod ▶/II.

On the center unit:

Press and hold iPod/USB MEMORY CONTROL ▷/II.

Turning off the system (on standby mode) or selecting another source also turns off the iPod.

Operations for USB MEMORY

- The icon such as  shows the file types the operation is available for.

The buttons described below are used on pages 22 to 26.

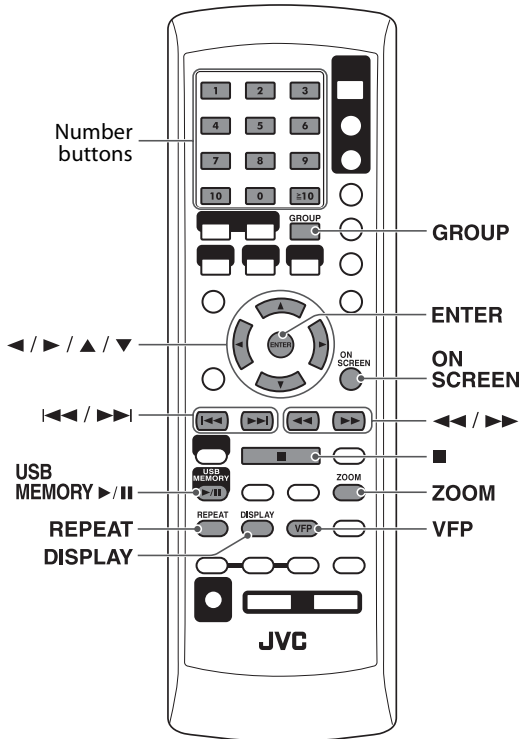

Basic operations for USB MEMORY

When “USB MEMORY” is selected as the source, the following messages will appear on the TV screen.

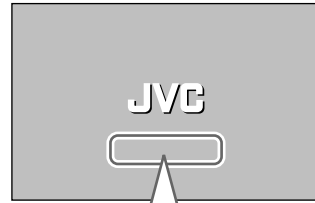

- “NOW READING”:
Appears when the system is reading the file information.
- “NO USB DEVICE”:
Appears when no USB mass storage class device is connected.
- “CANNOT PLAY THIS DEVICE”:
Appears when unplayable USB mass storage class device is connected or no supported file is stored.

CAUTION

- Always set volume to the minimum level when connecting or disconnecting the other equipment.
- You cannot send any data to your USB mass storage class device from this system.

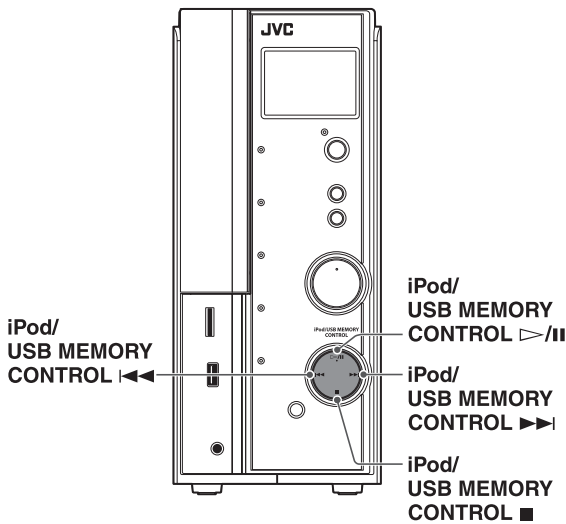

Basic playback for USB MEMORY

- To play a file in a USB mass storage class device



- 1 Connect a USB mass storage class device (see page 13) while the system is turned off.
- 2 Turn on the system. (see page 16)
- 3 Select "USB MEMORY" as the source. (see page 16)
- 4 Start playback.

On the remote control:

Press **USB MEMORY** ►/||.

On the center unit:

Press **iPod/USB MEMORY CONTROL** ▷/||.

The operations of the files in a USB mass storage class device depend on the file types stored in the device.

For MP3/WMA/WAV files

The file control display (see page 24) appears on the TV screen.

For JPEG files

Each file (still pictures) is shown on the TV screen for about 3 seconds (slide-show). When stop the playback, the file control display (see page 24) appears on the TV screen.

For MPEG-1/MPEG-2/ASF files

Pressing TOP MENU or MENU shows the file control display (see page 24) on the TV screen during playback.

NOTE

- When several types of files are recorded on a device, select file type you want to play on the setup menu. (see page 30)

- To stop

Press **■**.

- To pause

On the remote control:

Press **USB MEMORY** ►/|| during playback.

On the center unit:

Press **iPod/USB MEMORY CONTROL** ▷/|| during playback.

To continue playback, press the button again.

- Playback information on the display window

MP3/WMA/WAV/MPEG-1/MPEG-2/ASF file

Example: When an MP3 file is played back

Signal and speaker indicators (see page 28)

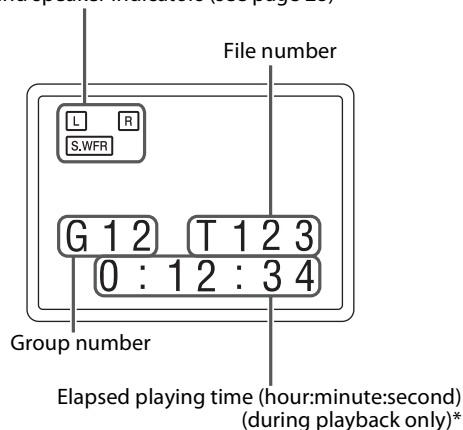

* Each time you press DISPLAY, the elapsed playing time and the file information appears alternately.

JPEG file

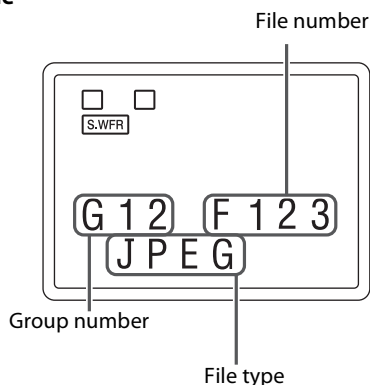

NOTE

- You can also check the playback information using the on-screen bar. (See page 24.)
- When playback is stopped, the file type is shown on the display window instead of elapsed playing time.

- Screen saver

An image may burn in on a TV screen if a static picture is displayed for a long time. To prevent this, the system automatically dims the screen if a static picture is displayed for over 5 minutes (the screen saver function).

- Pressing any button will cancel the screen saver function.
- If you do not want to use the screen saver function, see page 29.

Fast-forward/fast-reverse search

Press **◀◀** or **▶▶** during playback.

Each time you press the button, the search speed changes (x2, x5, x10, x20, x60).

To return to normal speed playback

Press USB MEMORY **▶/||** on the remote control.

NOTE

- When a MP3/WMA/WAV file is played back, sound is intermittent and low during fast-forward/reverse search.
- This feature may not work for some files.
- For MP3/WMA/WAV file, the search speed is not shown.



To skip files one by one

On the remote control:

Press **◀◀** or **▶▶**.

On the center unit:

Press **iPod/USB MEMORY CONTROL**

◀◀ or **▶▶**.

NOTE

- You can also make this operations using the file control display. (See page 24.)
- This feature may not work for some files.



To select a file directly

Press number buttons (0-10, ≥ 10) to select the desired number.

- For details on using the number buttons, see “How to use the number buttons” below.



How to use the number buttons

To select 3: Press 3.

To select 10: Press 10.

To select 14: Press ≥ 10 , 1, then 4.

To select 24: Press ≥ 10 , 2, then 4.

To select 40: Press ≥ 10 , 4, then 0.

To select 114: Press ≥ 10 , ≥ 10 , 1, 1, then 4.

To locate a desired group

1 Press **GROUP** during playback.

“- -” is shown in the group number area (see page 22) on the display window.

2 While the display window shows “- -”, use number buttons (0-10, ≥ 10) to enter the desired title or group number.

The system starts playback from the first file of the selected group.

- For details on using the number buttons, see “How to use the number buttons” on the left column.

NOTE

- This feature may not work for some files.

On-screen guide icons

During MPEG-1/MPEG-2/ASF file playback, the following guide icons may appear for a while on the TV screen;



- **▶** (Play), **||** (Pause), **▶▶** / **◀◀** (Fast forward/fast-reverse): appears when you perform each operation.
- **⊘**: the file cannot accept an operation you have tried to do.

NOTE

- To deactivate the on-screen guide icons, see page 31.

Advanced operations for USB MEMORY

Using the on-screen bar

You can check file information and use some functions through the on-screen bar.



■ Showing the on-screen bar

Press ON SCREEN.

Each time you press the button, the on-screen bar changes as follows on the TV screen.

Example: During ASF playback

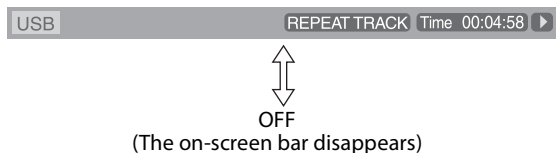

■ Contents of the on-screen bar during playback



- 1 Shows Repeat mode status. (See page 26.)
- 2 Shows time information.
- 3 Shows playback status.
 - ▶ : appears during playback.
 - ▶▶ / ◀◀ : appears during fast forward/reverse.
 - ⏸ : appears when paused.
 - ◻ : appears when stopped.

Using the file control display

You can search and play desired groups and tracks/files using the file control display on the TV screen.



Example:

Current group / total group number

Track information (for MP3/WMA/WAV only)

Repeat mode (See page 26.)

Elapsed playing time of current track (except for JPEG)

USB

Group : 3 / 3

Track : 10 / 30 (Total 1000)

Track Information

Title Meteor

Artist Gloster

Album Invincible birds

01. Gladiator.mp3

02. Hurricane.mp3

03. Spitfire.mp3

04. Defiant.mp3

05. Roc.mp3

06. Whirlwind.mp3

07. Typhoon.mp3

08. Tempest.mp3

09. Firebrand.mp3

10. Meteor.mp3

11. Hornet.mp3

12. Spiteful.mp3

Current group

Current track (file)

Current track (file) / total track (file) number on current group

Total track (file) number

Playback status

The file control display appears automatically during playback (for MP3/WMA/WAV only) or while stopped.

1 Press ◀/▶/▲/▼ to select the desired group/track/file while playback is stopped.

2 Press USB MEMORY ▶/⏸ or ENTER.

- Track playback/slide-show starts from the selected track/file.
- When you press ENTER for JPEG, only the selected file is played back.

To skip the file during playback

Press ▶▶/◀◀ or ▲/▼.

NOTE

- You can also check playback information on the display window. (See page 22.)
- Some group, track and file names may not be displayed correctly depending on recording conditions.
- The order of groups, tracks, and files may be displayed differently from the order displayed on your personal computer.

Resuming playback

When Resume Playback is set to "ON" (see page 31) and you stop playback by the following operations, the position where playback has been stopped is stored. ("RESUME" appears on the display window.)



- Turning off the power (see page 16)
- Pressing **■** once
- Changing the source (see page 16)

To start playback from the stored position

- Press USB MEMORY **▶/||** on the remote control or iPod/USB MEMORY CONTROL **▷/||** on the center unit.
- Select "USB MEMORY" as the source again if you changed the source.

To clear the stored position

Press **■** again.

- Disconnecting the USB mass storage class device also clears the stored position.

Zooming in

■ During playback or while paused

1 Press ZOOM.

Each time you repeat the procedure, the scene magnification changes.



2 While zoomed in, press **◀/▶/▲/▼** to move zoom-in area.

To return to normal playback

Press ZOOM repeatedly, to select OFF.

NOTE

- The number of the magnification steps varies depending on the file type.
- During slide-show playback of JPEG, zooming in is not available. In such a case, press USB MEMORY **▶/||** to pause slide-show playback, then zoom in.
- During playback, **◀/▶/▲/▼** may not work in step 2.

Changing the VFP setting

The VFP (Video Fine Processor) function enables you to adjust the picture character according to the type of programming, picture tone or personal preference.



■ During playback

1 Press VFP.

The current VFP settings appear on the TV screen.

Example:

NORMAL	
GAMMA	0
BRIGHTNESS	0
CONTRAST	0
SATURATION	0
TINT	0
SHARPNESS	0

2 Press **◀/▶** repeatedly to select the VFP mode.

- NORMAL: Normally select this.
- CINEMA: Suitable for movies.

When you select "NORMAL" or "CINEMA," press VFP to complete the setting.

- USER 1 and USER 2: You can adjust parameters that affect picture appearance.

Only when selecting "USER 1" or "USER 2" in step 2, proceed to perform the following operation;

3 Press **▲/▼** repeatedly to select a parameter you want to adjust.

Adjust gradually and confirm picture appearance results are as preferred.

- GAMMA: Control brightness of neutral tints while maintaining brightness of dark and bright portions (-3 to +3).
- BRIGHTNESS: Control screen brightness (-8 to +8).
- CONTRAST: Control screen contrast (-7 to +7).
- SATURATION: Control screen color depth (-7 to +7).
- TINT: Control screen tint (-7 to +7).
- SHARPNESS: Control screen sharpness (-8 to +8).

4 Press ENTER.

Example:



5 Press **▲/▼** to change the setting.

6 Press ENTER.

The current VFP settings appear again.

7 Repeat steps 3 to 6 to adjust other parameters.

8 Press VFP.

NOTE

- If the setting display disappears in the middle of the procedure, the setting at that time will be stored.

Repeating playback

When using the REPEAT button:
Press REPEAT.



Example:

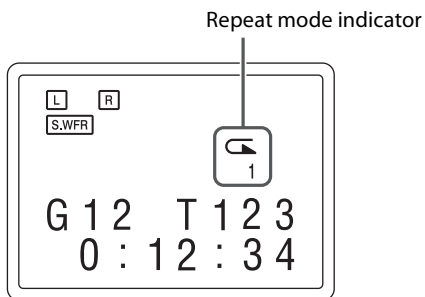

Each time you press REPEAT, the Repeat mode changes.

Display window	TV screen	Meanings
↶ 1	↶ TRACK	Repeats the current track/files.
	REPEAT TRACK	
↶	↶ GROUP	Repeats the current group.
	REPEAT GROUP	
↶ ALL	↶ ALL	Repeats all tracks/files.
	REPEAT ALL	
No indication	↶ OFF	Repeat mode is off. The system plays back the file normally.

Operations for surround mode

The buttons described below are used on page 28.

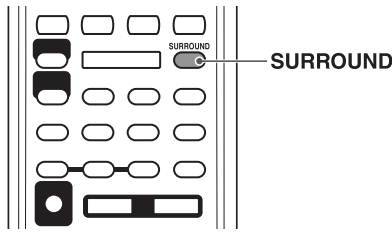

Using the surround mode

You can enjoy more realistic sound field than a stereo sound by using the surround mode.

- The surround modes are also available for external components.

■ Auto Surround (AUTO SURROUND)

This function automatically selects the appropriate surround mode according to the incoming signals. For example, a multi channel source is automatically reproduced in an appropriate multichannel surround mode.

■ Dolby Surround

Dolby Pro Logic II*¹

Dolby Pro Logic II has a developed multichannel playback format to decode all 2 channel sources — stereo source and Dolby Surround encoded source — into a 5.1 channel.

Dolby Pro Logic II has 2 modes — Movie and Music:

- **Pro Logic II Movie (DPL II MOVIE)**
Suitable for reproduction of Dolby Surround encoded sources bearing the mark [DOLBY SURROUND].
- **Pro Logic II Music (DPL II MUSIC)**
Suitable for reproduction of any 2 channel stereo music sources.

■ Dolby Digital*¹

Used to reproduce multichannel soundtracks of the software encoded with Dolby Digital ([DOLBY DIGITAL]).

- There are other encoding formats of digital surround introduced by Dolby Laboratories, such as Dolby Digital EX.

■ DTS Digital Surround*²

Used to reproduce multichannel soundtracks of the software encoded with DTS Digital Surround ([DTS DIGITAL SURROUND] or [DTS]).

DTS Digital Surround (dts SURROUND) is another discrete multi-channel digital audio format available on CD and DVD software.

- There are other encoding formats of multi-channel digital surround introduced by Digital Theater Systems, Inc., such as DTS-ES, DTS 96/24.

Available Surround modes for each input signal

The √ marks show available surround modes.

Signal	Mode	Surround off	Auto Surround	Dolby Surround		Dolby Digital	DTS Digital Surround	DSP		
		SURROUND OFF	AUTO SURROUND	DPL II MOVIE* ³	DPL II MUSIC* ³	DOLBY DIGITAL	dts SURROUND	STADIUM* ³	ALL CH STEREO* ³	GAME* ³
Dolby Digital (Multi-channel)		√	√	—	—	√	—	—	—	—
Dolby Digital (2 channel)		√	√	√	√	—	—	√	√	√
DTS Digital Surround (Multi-channel)		√	√	—	—	—	√	—	—	—
DTS Digital Surround (2 channel)		√	√	√	√	—	—	√	√	√
Analog or Linear PCM		√	√	√	√	—	—	√	√	√

*¹ Manufactured under license from Dolby Laboratories. “Dolby”, “Pro Logic”, and the double-D symbol are trademarks of Dolby Laboratories.

*² “DTS” and “DTS Digital Surround” are registered trademarks of DTS, Inc.

*³ You can select these modes by pressing SURROUND. (See page 28.)

Continued on the next page

■ DSP

• STADIUM

STADIUM mode adds clarity and spreads the sound, like in an outdoor stadium.

• All Channel Stereo

All Channel Stereo (ALL CH STEREO) mode can reproduce a larger stereo sound field using all the connected (and activated) speakers.

All Channel Stereo can be used while reproducing 2 channel stereo source.

Normal stereo sound

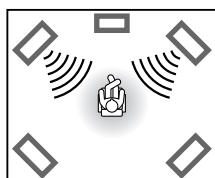

All Channel Stereo

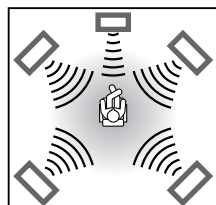

• Game

The surround effect with the optimum force for a game.

■ Indicators on the display window

Digital signal format indicators

LPCM: Lights when Linear PCM signal comes in.

DD: Lights when Dolby Digital signals come in.

dtS: Lights when DTS signals come in.

No indication: No digital signal indicator lights when analog signals come in.

Dolby Surround mode indicator

DDPLII: Lights when Dolby Pro Logic II is activated.

Surround indicator

SURR: Lights when the surround mode is activated.

Source signal indicators, etc.

Light to indicate the incoming signals.

L: Lights when the front left channel signal comes in.

C: Lights when the center channel signal comes in.

R: Lights when the front right channel signal comes in.

LFE: Lights when the LFE channel signal comes in.

LS: Lights when the surround left channel signal comes in.

RS: Lights when the surround right channel signal comes in.

s: Lights when the monaural surround channel signal or 2 channel Dolby Surround signal comes in.

S.WFR: Always lights.

The channel with “□” shows that the corresponding speakers are reproducing the channels’ sound.

If the channels’ sound decoded into 5.1 channel is reproduced, only “□” lights.

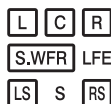

Selecting the surround mode

The system is set up to automatically select the optimal surround mode for input signal from digital multichannel software.

When playing back a 2 channel source, you can select the desired surround mode manually.

■ When playing back digital multichannel software (except while OFF is selected)

The appropriate multichannel surround mode (Dolby Digital or DTS Digital Surround) is automatically selected.

■ When playing back a 2 channel source

You can select either Dolby Pro Logic II (DPL II MOVIE/ DPL II MUSIC) or the DSP mode.

Press SURROUND repeatedly to select the desired mode.

The surround mode is turned on and the current surround mode appears on the display window.

Each time you press the button, the surround mode changes.

For details on each mode, see “Available Surround modes for each input signal”. (See page 27.)

To turn off the surround mode

Press SURROUND repeatedly until “SURROUND OFF” appears on the display window.

Storing adjustments — auto memory

When you turn the power off, the system memorizes the current surround mode. The memorized mode is automatically recalled when you turn the power on.

NOTE

- During playback of MPEG-1, MPEG-2 or ASF files, the surround mode setting is ineffective.

Setting preferences

The buttons described below are used on page 29 to 31.

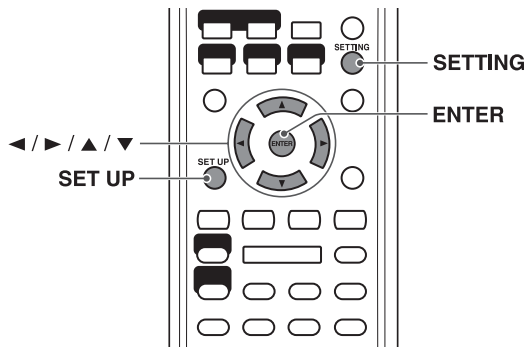

Using the setup menus

- You can change the language used in the setup menus. See “Menu description” below.

NOTE

- You can use SET UP menu only when the source is USB MEMORY.

Basic operation on the setup menus

- While stopped

1 Press SET UP.

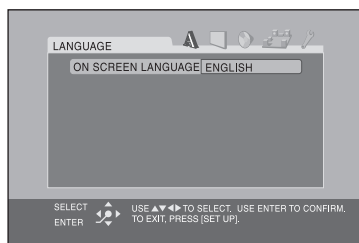

2 Follow the instructions that appear on the TV screen.

Menu description

A: Language menu (LANGUAGE)

■ ON SCREEN LANGUAGE

- Select the language shown on the TV screen when operating this system.

Picture menu (PICTURE)

■ MONITOR TYPE

You can select the monitor type to match your TV when you play files recorded in the picture's height/width ratio of 16:9.

- 16:9 NORMAL (Wide television screen)**
Select this when the aspect ratio of your wide TV is fixed to 16:9.
- 16:9 AUTO (Wide television conversion)**
Select this when your TV is an ordinary wide TV.
- 4:3 LB (Letter Box conversion)**
Select this when the aspect ratio of your TV is 4:3 (conventional TV). While viewing a wide screen picture, the black bars appear on the top and the bottom of the screen.
- 4:3 PS (Pan Scan conversion)**
Select this when the aspect ratio of your TV is 4:3 (conventional TV). While viewing a wide screen picture, the black bars do not appear, however, the left and right edges of the pictures will not be shown on the screen.

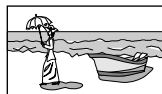

Ex.: 16:9

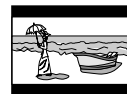

Ex.: 4:3 LB

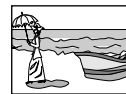

Ex.: 4:3 PS

NOTE

- Even if “4:3 PS” is selected, the screen size may become “4:3 LB” with some files. This depends on how files are recorded.

■ PICTURE SOURCE

You can obtain optimal picture quality by selecting whether the content of the file is processed by field (video source) or by frame (film source). Normally set to “AUTO”.

• AUTO

Used to play a file containing both video and film source materials.

This system recognizes the source type (video or film) of the current file according to the file information.

– If the playback picture is unclear or noisy, or the oblique lines of the picture are rough, try to change to fixed modes.

• FILM

Suitable for playing back a film source file.

• VIDEO

Suitable for playing back a video source file.

■ SCREEN SAVER (See page 22.)

You can activate or deactivate screen saver function.

■ FILE TYPE

When several types of files are recorded on a device, you can select which files to play.

- **AUDIO**
Select this to play MP3/WMA/WAV files.
- **STILL PICTURE**
Select this to play JPEG files.
- **VIDEO**
Select this to play MPEG-1/MPEG-2/ASF files.

Audio menu (AUDIO)

■ D. RANGE COMPRESSION (Dynamic range compression)

You can enjoy low level recorded sound clearly at night even at a low volume when listening to the sound with Dolby Digital.

- **AUTO**
Select this when you want to enjoy surround sound with its full dynamic range (no effect applied).
- **ON**
Select this when you want to fully apply the compression effect (useful at midnight).

NOTE

- When you play a multichannel Dolby Digital source with the surround mode is off, the setting of D. RANGE COMPRESSION is set to ON automatically.

Speaker setting menu (SPK. SETTING)

■ Level menu (LEVEL)

FRONT LEFT SPEAKER/FRONT RIGHT SPEAKER/ CENTER SPEAKER/SURROUND RIGHT SPEAKER/ SURROUND LEFT SPEAKER

While monitoring the test tone, adjust the output level of the speakers.

You can adjust the output level within the range of -6 dB to +6 dB.

TEST TONE*

Emits the test tone.

- * The test tone comes out of all of the activated speakers in the following sequence:
⇒ **Front left speaker** ⇒ **Center speaker** ⇒ **Front right speaker** ⇒ **Surround right speaker** ⇒ **Surround left speaker** ⇒ **(back to the beginning)**

NOTE

- No test tone comes out of the subwoofer.

■ Delay menu (DELAY)

Example:

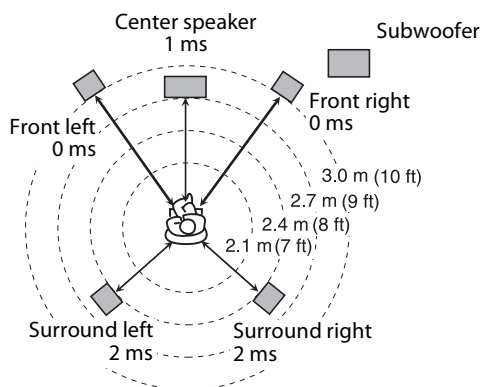

1 ms increase (or decrease) in delay time corresponds to about 30 cm (1 ft) decrease (or increase) in distance.

Set to "0 ms" for the furthest speaker from your position as the basis for the delay time setting.

In this case, set the delay time of each speaker as follows;

- Delay time of front speakers: 0 ms
- Delay time of center speaker: 1 ms
- Delay time of surround speakers: 2 ms

FRONT LEFT SPEAKER/FRONT RIGHT SPEAKER/ CENTER SPEAKER/SURROUND RIGHT SPEAKER/ SURROUND LEFT SPEAKER

Adjust the distance from the listening position to the speakers.

Within the range of 0 ms to 15 ms (by 1 ms).

■ Subwoofer menu (SUBWOOFER)

LEVEL

You can set the output level of the subwoofer within the range of -6 dB to +6 dB.

CROSS OVER

The signals below the preset frequency level will be sent to and be reproduced by the subwoofer.

Select one of the crossover frequency levels according to the size of the small speaker connected.

- **120Hz:** Select when the cone speaker unit built in the speaker is about 8 cm (3-3/16 inches).
- **150Hz:** Select when the cone speaker unit built in the speaker is about 6 cm (2-3/8 inches).
- **200Hz:** Select when the cone speaker unit built in the speaker is about 5 cm (2 inches).

NOTE

- When you use a supplied subwoofer (SP-THL1W), select "150Hz."

Other setting menu (OTHERS)

■ RESUME (See page 25.)

You can activate or deactivate Resume Playback function.

■ ON SCREEN GUIDE

You can activate or deactivate the on-screen guide icons. (See page 23.)

Setting the audio terminal

You can set the analog or digital audio input terminal to use with the source of VIDEO 1-3.

NOTE

- Before you start the operation; There is a time limit in doing the following steps. If the setting is canceled before you finish, start from step 2 again.

1 Select "VIDEO 1", "VIDEO 2" or "VIDEO 3" as the source. (see page 16)

2 Press SETTING.

Example:



3 Press ▲/▼ to select the source you want to set.

- V1 A/D: For the source of VIDEO 1
- V2 A/D: For the source of VIDEO 2
- V3 A/D: For the source of VIDEO 3

4 Press ◀/▶ to select the audio input terminal you want to use for the source selected in the above step.

Example:



- **ANALOG:** Signal from AUDIO jacks comes out of the speakers (see page 10 to 12).
- **DIGITAL:** Signal from DIGITAL IN terminal comes out of the speakers (see page 10 to 12).

NOTE

- If you press DVD ▶ or DVD ■ in the middle of the procedure, you cannot select ANALOG/DIGITAL by pressing ◀/▶. In this case, press the button for the current source (VIDEO1, VIDEO2 or VIDEO3) then press ◀/▶ to select ANALOG/DIGITAL.

References

Troubleshooting

	PROBLEM	POSSIBLE CAUSE	SOLUTION
POWER	Power does not come on.	The power cord is not connected.	Connect the power cord correctly. (See page 13.)
	The system suddenly turns off.	The playback level of the current source is too high.	Play back the source with lower volume level.
REMOTE CONTROL	The remote control does not work.	The batteries are exhausted.	Replace the batteries. (See page 6.)
		Sunlight is shining directly on the remote sensor.	Hide the remote sensor from direct sunlight.
	The remote control does not work as expected.	The remote control mode is not for the desired source.	Before operation, press one of the source selecting buttons for the desired source.
SOUND	No sound.	The speaker cord is not connected.	Check the connection. (See page 7.)
		An incorrect source has been selected.	Select the correct source. (See page 16.)
PICTURE	No picture is displayed on the TV screen.	The video cord is not connected correctly.	Connect the cable correctly. (See page 9.)
		The file is not playable.	Use a playable file. (See pages 3.)
	No picture is displayed on the TV or no sound come out through HDMI connection.	The connected TV is not HDCP-compatible.	Use a HDCP-compatible TV.
		The HDMI cord is not connected correctly.	Disconnect the HDMI cable and connect it again.
	No picture is displayed on the TV screen, the picture is blurred, or the picture is divided into two parts.	The scan mode is set to "PROGRESS" though the center unit is connected to the TV which does not support the progressive video input.	Change the scan mode to "INT-LACE". (See page 18.)
The picture does not fit the TV screen.	The monitor type is not set correctly.	Set "MONITOR TYPE" properly. (See page 29.)	
PLAYBACK	The iPod does not play even though "CONNECT" appears on the display.	The battery of the iPod is exhausted.	Leave the iPod connected for at least 10 minutes.
		The iPod battery charge function is deactivated.	Activate the iPod battery charge function. (See page 19.)
		The iPod is not compatible with the System.	Check the compatibility on the list. (See page 19.)
	The iPod is not charged.	The source is not "iPod."	Change the source to "iPod." (See page 16.)
		The iPod battery charge function is deactivated.	Activate the iPod battery charge function. (See page 19.)
	Video and audio are distorted.	A video component is connected between the center unit and the TV.	Connect the center unit and TV directly. (See page 9.)
Surround modes of "DOLBY DIGITAL" or "dts SURROUND" are not available to use.	"ANALOG" is selected on the setting of the audio terminals.	Select "DIGITAL" on the setting of the audio terminals.	
	The external component is not connected with the digital audio cord (coaxial or optical) or HDMI cord.	Connect the external component with the digital audio cord (coaxial or optical) or HDMI cord. (See pages 10 to 12.)	

Specifications

■ Center unit

Output power

Front/Surround:	40 W per channel, RMS at 3 Ω at 1 kHz, with 10% total harmonic distortion.
Center:	100 W, RMS at 4 Ω at 1 kHz, with 10% total harmonic distortion.
Subwoofer:	100 W, RMS at 4 Ω at 30 Hz, with 10% total harmonic distortion.

Audio section

Analog Input

VIDEO 1 IN, VIDEO 2 IN, VIDEO 3: 500 mV/50 k Ω

Digital Input*

VIDEO 1, VIDEO 3:
-21 dBm to -15 dBm (660 nm ± 30 nm)
VIDEO 2: 0.5 V(p-p)/75 Ω

Video section

Video System:	NTSC
Horizontal Resolution:	500 lines
Signal-to-Noise Ratio:	60 dB
Video output level	

Composite: 1 V(p-p)/75 Ω
S-video-Y: 1 V(p-p)/75 Ω
S-video-C: 0.286 V(p-p)/75 Ω
Component (Interlace/Progressive):
Y: 1 V(p-p)/75 Ω
PB/PR: 0.7 V(p-p)/75 Ω

HDMI

HDMI Input:	VIDEO 1 IN, VIDEO 2 IN
HDMI Output:	MONITOR OUT
Max capability:	1920 × 1080 at 60 Hz / Deep color [4:4:4] / color depth 24 bit.

USB storage

USB specification:	Compatible with USB 2.0 Full Speed
Compatible device:	Mass Storage Class
Compatible file system:	FAT16, FAT32
Bus power supply:	5 V/500 mA

Speaker impedance

Front and Surround:	3 Ω to 16 Ω
Center and Subwoofer:	4 Ω to 16 Ω

General

Power Requirements:	AC 120 V ~, 60 Hz
Power supply to iPod:	5 V/500 mA
Power Consumption:	50 W (at operation) 0.8 W (in standby mode)
Dimensions (W × H × D):	118 mm × 276 mm × 246 mm (4-11/16 inches × 10-15/16 inches × 9-11/16 inches)
Mass:	2.9 kg (6.4 lbs)

■ Subwoofer (SP-THL1W)

Type:	1-way Bass-Reflex Type (Magnetically-Shielded Type)
Speaker:	16 cm (6-5/16 inches) cone × 1
Power Handling Capacity:	100 W
Impedance:	4 Ω
Frequency Range:	30 Hz to 1.5 kHz
Sound Pressure Level:	84 dB/W-m
Dimensions (W × H × D):	266 mm × 270 mm × 157 mm (10-1/2 inches × 10-11/16 inches × 6-3/16 inches)
Mass:	2.9 kg (6.4 lbs)

■ Satellite speakers

Front speakers (SP-THL1F)

Type:	Full-Range Bass-Reflex Type (Magnetically-shielded Type)
Speaker:	6.5 cm (2-9/16 inches) cone × 1
Power Handling Capacity:	40 W
Impedance:	3 Ω
Frequency Range:	90 Hz to 20 kHz
Sound Pressure Level:	77 dB/W-m
Dimensions (W × H × D):	100 mm × 104 mm × 105 mm (3-15/16 inches × 4-1/8 inches × 4-3/16 inches)
Mass:	0.42 kg (0.93 lbs) each

Center speaker (SP-THL1C)

Type:	Full-Range Bass-Reflex Type (Magnetically-shielded Type)
Speaker:	6.5 cm (2-9/16 inches) cone × 1
Power Handling Capacity:	100 W
Impedance:	4 Ω
Frequency Range:	90 Hz to 20 kHz
Sound Pressure Level:	77 dB/W-m
Dimensions (W × H × D):	100 mm × 104 mm × 105 mm (3-15/16 inches × 4-1/8 inches × 4-3/16 inches)
Mass:	0.42 kg (0.93 lbs) each

Surround speakers (SP-THL1S)

Type:	Full-Range Bass-Reflex Type
Speaker:	6.5 cm (2-9/16 inches) cone × 1
Power Handling Capacity:	40 W
Impedance:	3 Ω
Frequency Range:	90 Hz to 20 kHz
Sound Pressure Level:	76 dB/W-m
Dimensions (W × H × D):	100 mm × 104 mm × 105 mm (3-15/16 inches × 4-1/8 inches × 4-3/16 inches)
Mass:	0.5 kg (1.2 lbs) each

Designs & specifications are subject to change without notice.

* Corresponding to Linear PCM, Dolby Digital, and DTS Digital Surround (with sampling frequency — 32 kHz, 44.1 kHz, 48 kHz)

TO OUR VALUED CUSTOMER ———

THANK YOU FOR PURCHASING THIS JVC PRODUCT.
WE WANT TO HELP YOU ACHIEVE A PERFECT EXPERIENCE.

**NEED HELP ON HOW TO HOOK UP?
NEED ASSISTANCE ON HOW TO OPERATE?
NEED TO LOCATE A JVC SERVICE CENTER?
LIKE TO PURCHASE ACCESSORIES?**

JVC[®] IS HERE TO HELP!
TOLL FREE: 1(800)252-5722
<http://www.jvc.com>

Remember to retain your Bill of Sale for Warranty Service.

————— **Do not attempt to service the product yourself** —————

Caution

To prevent electrical shock, do not open the cabinet.
There are no user serviceable parts inside.
Please refer to qualified service personnel for repairs.



LIMITED WARRANTY

USA ONLY

ONLY FOR PRODUCT PURCHASED IN U.S.A.

CONSUMER VIDEO 1-90

JVC COMPANY OF AMERICA (JVC) warrants this product and all parts thereof, except as set forth below ONLY TO THE ORIGINAL RETAIL PURCHASER to be FREE FROM DEFECTIVE MATERIALS AND WORKMANSHIP from the date of original purchase for the period shown below. ("The Warranty Period")

PARTS	1 YR	LABOR	90 DAYS
-------	------	-------	---------

THIS LIMITED WARRANTY IS VALID ONLY IN THE FIFTY (50) UNITED STATES, THE DISTRICT OF COLUMBIA AND IN THE COMMONWEALTH OF PUERTO RICO.

WHAT WE WILL DO:

If this product is found to be defective within the warranty period, JVC will repair or replace defective parts with new or rebuilt equivalents at no charge to the original owner. Such repair and replacement services shall be rendered by JVC during normal business hours at JVC authorized service centers. Parts used for replacement are warranted only for the remainder of the Warranty Period. All products may be brought to a JVC authorized service center on a carry-in basis. Color televisions with a screen size of 27" or greater qualify for in-home service. In such cases, a technician will come to your home and either repair the TV there or remove and return it if it cannot be repaired in your home.

WHAT YOU MUST DO FOR WARRANTY SERVICE:

Please do not return your product to the retailer
Instead, return your product to the JVC authorized service center nearest you. If shipping the product to the service center, please be sure to package it carefully, preferably in the original packaging, and include a brief description of the problem(s). Please call 1-800-252-5722 to locate the nearest JVC authorized service center. Service locations can also be obtained from our website <http://www.jvc.com>. If your product qualifies for in-home service, the service representative will require clear access to the product.

If you have any questions concerning your JVC Product, please contact our Customer Relations Department at 800-252-5722

WHAT IS NOT COVERED:

This limited warranty provided by JVC does not cover:

1. Products which have been subject to abuse, accident, alteration, modification, tampering, negligence, misuse, faulty installation, lack of reasonable care, or if repaired or serviced by anyone other than a service facility authorized by JVC to render such service, or if affixed to any attachment not provided with the products, or if the model or serial number has been altered, tampered with, defaced or removed;
2. Initial installation, installation and removal from cabinets or mounting systems.
3. Operational adjustments covered in the Owner's Manual, normal maintenance, video and audio head cleaning;
4. Damage that occurs in shipment, due to act of God, and cosmetic damage;
5. Signal reception problems and failures due to line power surge;
6. User Removal Memory Devices/Video Pick-up Tubes/CCD Image Sensors are covered for 90days from the date of purchase;
7. Accessories;
8. Batteries (except that Rechargeable Batteries are covered for 90 days from the date of purchase);
9. Products used for commercial purposes, including, but not limited to rental.
10. Loss of data resultant from malfunction of hard drive or other data storage device.

There are no express warranties except as listed above.

THE DURATION OF ANY IMPLIED WARRANTIES, INCLUDING THE IMPLIED WARRANTY OF MERCHANTABILITY, IS LIMITED TO THE DURATION OF THE EXPRESS WARRANTY HEREIN.

JVC SHALL NOT BE LIABLE FOR ANY LOSS OF USE OF THE PRODUCT, INCONVIENCE, OR ANY OTHER DAMAGES, WHETHER DIRECT, INCIDENTAL OR CONSEQUENTIAL (INCLUDING, WITHOUT LIMITATION, DAMAGE TO TAPES, RECORDS OR DISCS) RESULTING FROM THE USE OF THIS PRODUCT, OR ARISING OUT OF ANY BREACH OF THIS WARRANTY. ALL EXPRESS AND IMPLIED WARRANTIES, INCLUDING THE WARRANTIES OF MERCHANTABILITY AND FITNESS FOR PARTICULAR PURPOSE, ARE LIMITED TO THE WARRANTY PERIOD SET FORTH ABOVE.

Some states do not allow the exclusion of incidental or consequential damages or limitations on how long an implied warranty lasts, so these limitations or exclusions may not apply to you. This warranty gives you specific legal rights and you may also have other rights which vary from state to state.

JVC COMPANY OF AMERICA
DIVISION OF JVC AMERICAS CORP.

1700 Valley Road
Wayne, NJ 07470

<http://www.jvc.com>

REFURBISHED PRODUCTS CARRY A SEPARATE WARRANTY, THIS WARRANTY DOES NOT APPLY. FOR DETAIL OF REFURBISHED PRODUCT WARRANTY, PLEASE REFER TO THE REFURBISHED PRODUCT WARRANTY INFORMATION PACKAGED WITH EACH REFURBISHED PRODUCT.

For customer use:

Enter below the Model No. and Serial No. which is located either on the rear, bottom or side of the cabinet. Retain this information for future reference.

Model No. : _____

Serial No. : _____

Purchase date : _____

Name of dealer : _____

JVC