

SIEMENS

**Siemens BACnet
VAV Actuator
Owner's Manual**

125-5037 Rev. AA, February 2008

Rev. AA, February 2008

NOTICE

The information contained within this document is subject to change without notice and should not be construed as a commitment by Siemens Building Technologies, Inc. Siemens Building Technologies, Inc. assumes no responsibility for any errors that may appear in this document.

All software described in this document is furnished under a license and may be used or copied only in accordance with the terms of such license.

WARNING

This equipment generates, uses, and can radiate radio frequency energy and if not installed and used in accordance with the instructions manual, may cause interference to radio communications. It has been tested and found to comply with the limits for a Class A digital device, pursuant to Part 15 of the FCC rules. These limits are designed to provide reasonable protection against such interference when operated in a commercial environment. Operation of this equipment in a residential area is likely to cause interference in which case users at their own expense will be required to take whatever measures may be required to correct the interference.

SERVICE STATEMENT

Control devices are combined to make a system. Each control device is mechanical in nature and all mechanical components must be regularly serviced to optimize their operation. All Siemens Building Technologies branch offices and authorized distributors offer Technical Support Programs that will ensure your continuous, trouble-free system performance.

For further information, contact your nearest Siemens Building Technologies, Inc. representative.

Copyright 2008 by Siemens Building Technologies, Inc.

TO THE READER

Your feedback is important to us. If you have comments about this document, please send them to SBT_technical.editor.us.sbt@siemens.com

CREDITS

Product or company names mentioned herein may be the trademarks of their respective owners.

Country of Origin: US

Table of Contents

How To Use This Manual	V
Manual Organization	V
Manual Conventions	VI
Manual Symbols	VI
Getting Help	VI
Where To Send Comments	VI
Product Overview	1
Introduction	1
Ordering Notes	1
Hardware Inputs	2
Analog	2
Digital	2
Hardware Outputs.....	2
Analog	2
Digital	3
Power Wiring.....	3
Communication Wiring.....	4
Controller LED Indicators.....	4
Temperature Sensors.....	4
Room Temperature Sensor.....	4
Duct Temperature Sensor.....	5
Related Equipment.....	5
Applications	6
Basic Operation	6
Sequencing Logic (optional)	6
Control Temperature Setpoints.....	6
Day/Night Mode	6
Night Mode Override Switch	6
Control Loops.....	6
Calibration.....	7
Damper Status Operation	7

Fail-safe Operation	7
Heating and Cooling Switchover	7
Modulate Damper During Heating Mode (optional).....	7
Hot Water Reheat	8
Electric Reheat.....	8
Notes.....	8
Application 2560 VAV Cooling Only.....	9
Overview	9
Application 2561 VAV Cooling or Heating.....	10
Overview	10
Application 2562 VAV with Electric Reheat or Baseboard Radiation.....	11
Overview	11
Baseboard Radiation	11
Electric Heat Interlock.....	11
Application 2563 VAV with Hot Water Reheat	13
Overview	13
Application 2564 VAV Series Fan Powered with Electric Reheat.....	15
Overview	15
Fan Operation	15
Application 2565 VAV Series Fan Powered with Hot Water Reheat.....	16
Overview	16
Fan Operation	16
Application 2566 VAV Parallel Fan Powered with Electric Reheat.....	17
Overview	17
Fan Operation	17
Application 2567 VAV Parallel Fan Powered with Hot Water Reheat.....	18
Overview	18
Fan Operation	18
Application 2597 Slave Mode.....	19
Overview	19
Using Auxiliary Points	19
Using the Controller as a Point Extension Device	19

Point Database	20
Overview	20
Troubleshooting.....	29
Basic Service Information	29
Preventive Maintenance	29
Safety Features.....	30
Controller LEDs.....	30
Automated Checkout.....	30
Glossary	33
Overview	33
Index	37

How To Use This Manual

This manual is written for the owner and user of Siemens Building Technologies BACnet VAV Actuator. It is designed to help you become familiar with the Siemens BACnet VAV Actuator and its applications.

This section covers manual organization, manual conventions, symbols used in the manual, and other information that will help you use this manual.

Manual Organization

This manual contains the following chapters:

- *Chapter 1, Hardware*, describes the hardware components and the accessories that are used with the BACnet VAV Actuator.
- *Chapter 2, Applications for BACnet VAV Actuator*, describes the control applications available in the model of the BACnet VAV Actuator that includes a terminal block for wireable input/output connections.
- *Chapter 3, Point Database*, defines the point database descriptors and includes address and applications.
- *Chapter 4, Troubleshooting*, describes basic corrective measures you can take should you encounter a problem when using the BACnet VAV Actuator. For issues not covered in this chapter, consult your local Siemens Building Technologies, Inc., representative.
- The *Glossary* describes the terms and acronyms used in this manual.
- The *Index* helps you locate information presented in this manual.



Manual Conventions

The following table lists conventions to help you use this manual in a quick and efficient manner.

Convention	Example
Actions that you should perform are specified in boldface font.	Type F for Field panels. Click OK to save changes and close the dialog box.
Error and system messages are displayed in Courier New font.	The message Report Definition successfully renamed appears in the status bar.
New terms appearing for the first time are italicized.	The Open Processor continuously executes a user-defined set of instructions called the <i>control program</i> .

Manual Symbols

The following table lists the symbols used in this owner's manual to draw your attention to important information.

Notation	Symbol	Meaning
WARNING:		Indicates that personal injury or loss of life may occur to the user if a procedure is not performed as specified.
CAUTION:		Indicates that equipment damage or loss of data may occur if the user does not follow a procedure as specified.

Getting Help

For more information about the BACnet VAV Actuator, contact your local Siemens Building Technologies, Inc. representative.

Where To Send Comments

Your feedback is important to us. If you have comments about this manual, please submit them to SBT_technical.editor.us.sbt@siemens.com.

1

Product Overview

Introduction

The BACnet VAV Actuator is the Siemens Building Technologies, Inc. FLN controller used in pressure independent Variable Air Volume applications (Figure 1). It provides Direct Digital Control (DDC) for eight applications, and can operate independently as a stand-alone DDC room controller or networked with a field panel. The controller provides all input/output, system, and local communication connections. Hardware consists of the controller and the mounting bracket.

Table 1 lists the BACnet VAV Actuator products that are covered:

Table 1. BACnet VAV Actuator – Electronic Output Applications.

Application Number	Application Description
2560	VAV Cooling Only
2561	VAV Cooling or Heating
2562	VAV with Electronic Reheat or Baseboard Radiation
2563	VAV with Hot Water Reheat
2564	VAV Series Fan Powered with Electric Reheat
2565	VAV Series Fan Powered with Hot Water Reheat
2566	VAV Parallel Fan Powered with Electric Reheat
2567	VAV Parallel Fan Powered with Hot Water Reheat
2597	Slave Mode

Ordering Notes

BACnet VAV Actuator (GDE Actuator)	550-430
BACnet VAV Actuator (GLB Actuator)	550-431

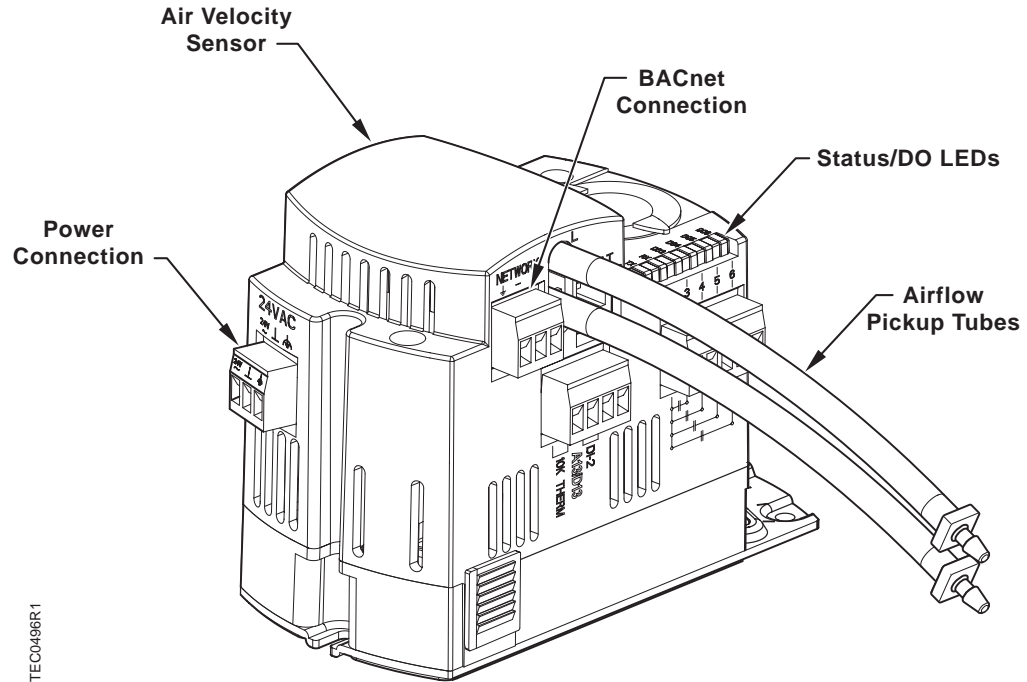

Figure 1. Siemens BACnet VAV Actuator.

Hardware Inputs

Analog

- Air Velocity Sensor (AVS)
- Duct temperature sensor (optional)
- Room temperature sensor (RTS)
- Room temperature setpoint dial (optional)

Application 2561

Digital

- Night mode override (optional)
- Wall switch (optional)

Hardware Outputs

Analog

- None

Digital

	Application
• Autozero Module (AZM) (optional)	2560, 2561, 2562, 2563
• Damper Actuator	All
• Fan	2565, 2566, 2567
• First valve actuator (required)	2563
• Second valve actuator (optional) or AZM (optional)	2563
• Stage 1 electric reheat; or, 2-position heating valve	2562
• Stage 1 electric reheat	2564, 2566
• Stage 2 electric reheat (optional)	2562, 2564, 2566
• Stage 3 electric reheat (optional)	2562, 2564, 2566
• Valve actuator	2565, 2567

Power Wiring

The controller is powered by 24 Vac. Power wiring connects to the two screw terminals on the controller labeled “C” (Common) and “H” (Hot) on the terminal block labeled “24 VAC”. No earth ground connection is required (Figure 2).

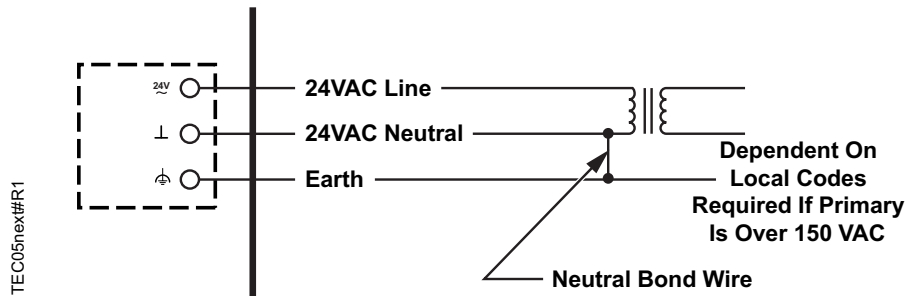

Figure 2. Power Wiring.

Communication Wiring

The controller connects to the field panel by means of a Floor Level Network (FLN) trunk. Communication wiring connects to the three screw terminals on the controller labeled “+” (positive), “-“(negative), and “S” (Shield) (Figure 3).

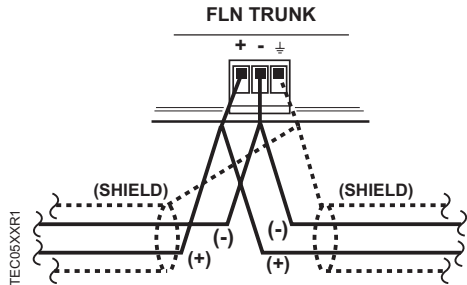

Figure 3. Communication Wiring (2-wire).

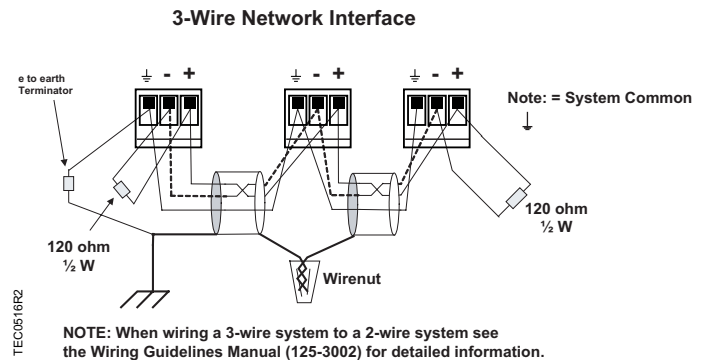

Figure 4. Communication Wiring (3-wire).

Controller LED Indicators

The controller has seven Light Emitting Diode (LED) indicators (see Figure 1).

Table 2. Controller LEDs.

LED Type	Label (if present)*	LED Number	Indication
DO	LED 3 - LED 6	3 - 6	Indicates the ON/OFF status of the DO associated with it. A glowing LED indicates that the DO is energized.
Transmit	TX	0	Indicates, when flashing, that the controller is transmitting information to the field panel.
Receive	RX	1	Indicates, when flashing, that the controller is receiving information from the field panel.
BST "Basic Sanity Test"	BST	2	Indicates, when flashing ON and OFF once per second, that the controller is functioning properly.

* Some LED labels and numerals may be hidden by the controller cover.

Temperature Sensors

Room Temperature Sensor

The controller room temperature sensor connects to the controller by means of a cable terminated at both ends with a six-conductor RJ-11 plug-in connector.

Duct Temperature Sensor

An optional duct temperature sensor provides duct air temperature sensing inputs to the controller.

For more information about temperature sensors, contact your local Siemens Building Technologies, Inc. representative.

Related Equipment

- Autozero Module (optional) 540-200
- Relay Module
- Damper Actuator(s)
- Duct Temperature Sensor (10K Ω) (optional)
- Room Temperature Sensor

Contact your local Siemens Building Technologies, Inc. representative for product numbers and more information.

2

Applications

Basic Operation

The BACnet VAV Actuator provides Direct Digital Control (DDC) for Variable Air Volume (VAV) terminal box applications. Temperature control varies with the application. If present, heating can be provided by hot water, up to three stages of electric reheat, or optional baseboard radiation.

Sequencing Logic (optional)

This application has the additional capability to sequence the flow and mechanical heating when heated supply air is available.

Control Temperature Setpoints

The controller maintains a specified temperature setpoint based on Day/Night mode, or the heating/cooling mode, or the setpoint dial (if used).

Day/Night Mode

The controller maintains the specified day setpoint temperature during daytime hours and the specified night setpoint at night.

Night Mode Override Switch

If the ROOM TEMPERATURE SENSOR has an override switch, it can be used to command the controller into day mode for an adjustable period of time. This only affects a controller in night mode.

Control Loops

Temperature Loop – Heating Loop – Cooling Loop – maintain temperature setpoint by changing the flow setpoint or modulating the heat source (valve/electric heat).

Flow Loop – maintains flow setpoint by modulating the damper actuator.

Calibration

Air Velocity Sensor - Calibration of the controller's internal air velocity sensor is periodically required to maintain accurate air velocity readings. Calibration may be set to take place automatically or manually.

Autozero Module (AZM) – Used when damper cannot be closed and constant airflow is needed.

- For a controller used with an AZM, calibration occurs without closing the damper. Application 2560, 2561, 2562, 2563.
- For a controller used without an AZM, the damper is briefly commanded closed to get a zero airflow reading and an accurate damper position during calibration. Application 2560, 2561, 2562, 2563.

Hot Water Valve – Calibration of a hot water valve (if used) is done by briefly commanding the valve closed. Application 2562, 2565, 2567.

Damper Status Operation

When using an AZM it is possible, after a period of operation, for the calculated damper position to differ from the actual (physical) damper position.

If this occurs, the controller will *automatically* compensate for any difference by readjusting the calculated damper position. This calculated position may not match the actual position.

Fail-safe Operation

If the air velocity sensor fails, the controller uses pressure dependent control. The temperature loop controls the operation of the damper.

If the room temperature sensor fails, then the controller operates using the last known temperature value.

Heating and Cooling Switchover

The heating/cooling switchover determines whether the controller is in heating or cooling mode by monitoring the room temperature and the demand for heating and cooling (as determined by the temperature control loops).

Modulate Damper During Heating Mode (optional)

Applications that have a heating source (valve/electric) can be configured to modulate the flow setpoint in sequence with the heating source.



CAUTION:

If the damper is set to modulate in heating mode, make sure the controller is in the appropriate mode for the current supply air temperature.

Hot Water Reheat



CAUTION:

Do not set HTG FLOW MIN to 0 cfm (0 lps). A minimum airflow should be provided across the heating coils when the heating valve is open.

When the controller is in cooling mode, the heating valve(s) are closed.

The heating loop modulates the heating valve(s) to warm up the room. In cooling mode, the heating valve is closed.

Electric Reheat



CAUTION:

Verify that the equipment is supplied with safeties by others to ensure that there is airflow across the heating coils when they are to be energized.

The heating loop controls up to three stages of electric reheat to warm up the room. The electric reheat is time modulated using a duty cycle. When the controller is in cooling mode, the electric heat is OFF at all times.

Notes

1. If the temperature swings in the room are excessive or if there is trouble in maintaining the setpoint, contact your local Siemens Building Technologies, Inc. representative for more information.
2. The BACnet VAV Actuator, as shipped from the factory, keeps all associated equipment OFF. The controller and its equipment are released to application control at start-up.
3. "Safeties by Others": This note implies that the associated equipment has safety features installed, for example adding mechanical stops to the dampers.

Application 2560 VAV Cooling Only

Overview

In Application 2560, the controller modulates the supply air damper of the terminal box for cooling. In order for it to work properly, the central air-handling unit must provide cool supply air. See Figure 5.

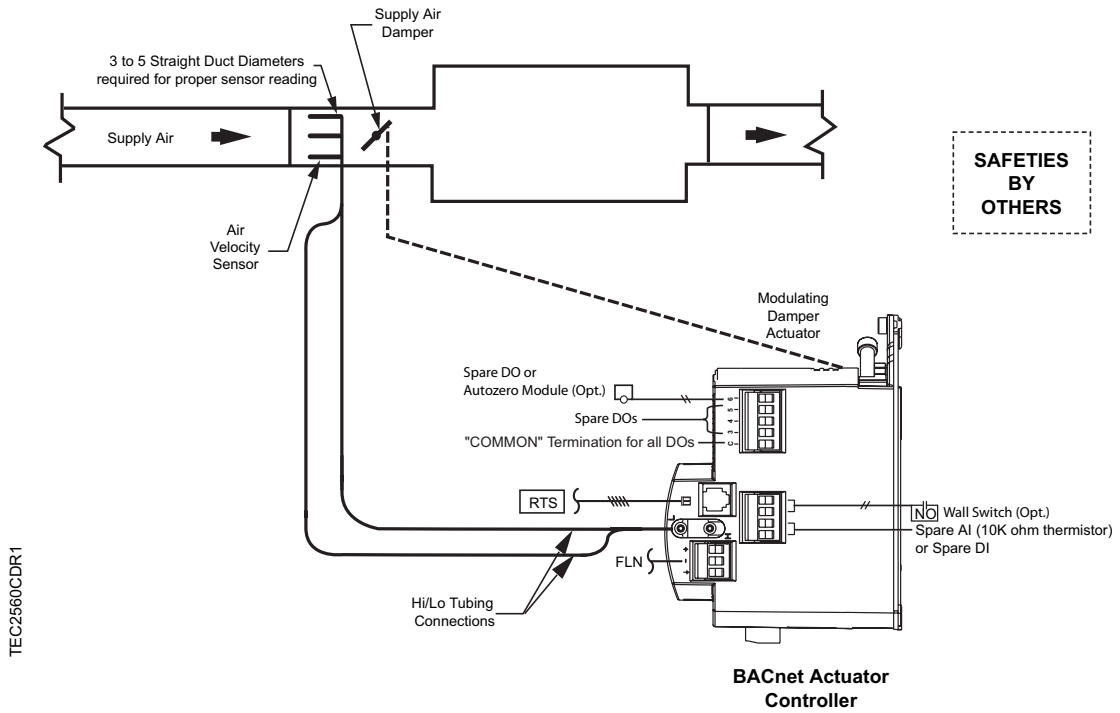

Figure 5. Application 2560 Control Drawing.

Application 2561 VAV Cooling or Heating

Overview

In Application 2561, the controller modulates the supply air damper of the terminal box for cooling and heating. In order for it to work properly, the central air-handling unit must provide cool supply air in cooling mode and warm air in heating mode. See Figure 6.

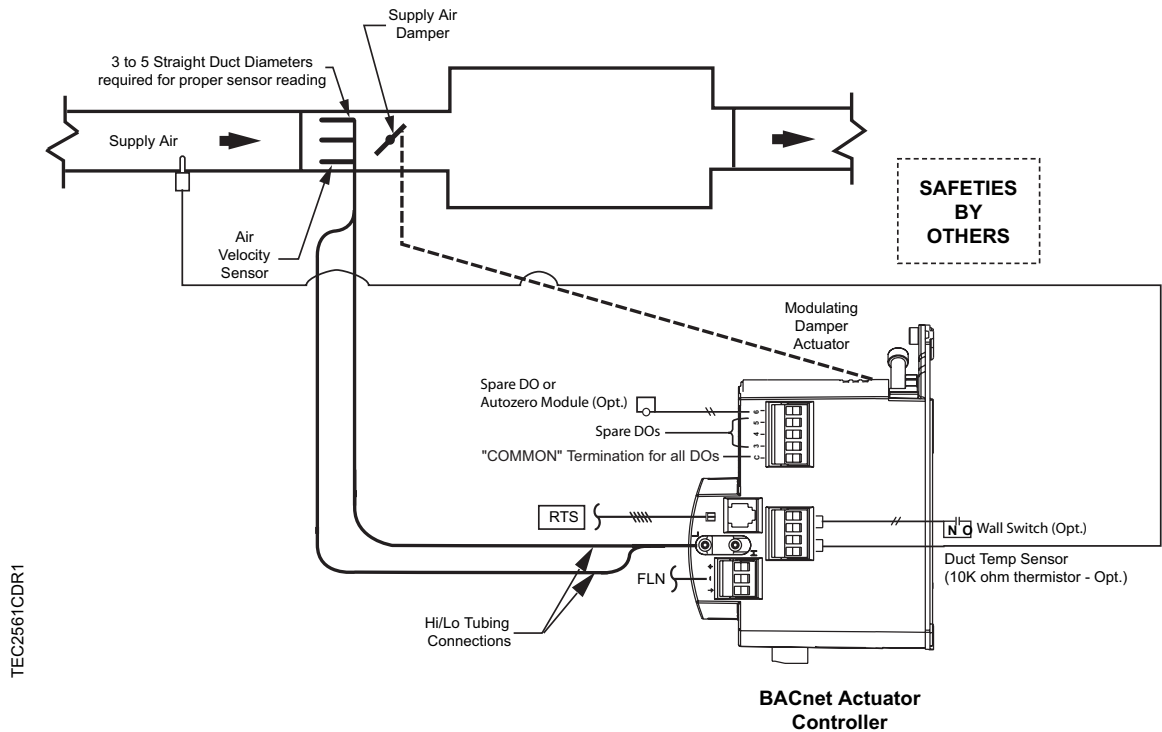

Figure 6. Application 2561 Control Drawing.

Application 2562 VAV with Electric Reheat or Baseboard Radiation

Overview

In Application 2562, the controller modulates the supply air damper for the terminal box for cooling and controls stages of electric reheat or baseboard radiation for heating. When in heating, the terminal box either maintains minimum airflow or modulates the supply air damper. In order for the terminal box to work properly, the central air-handling unit must provide supply air. See Figure 7 and Figure 8.

Baseboard Radiation

Baseboard radiation can be a two-position valve or electrical resistance heating.

If the controller is in cooling mode, the heating valve is closed. When in heating mode, the controller will operate the heating valve to maintain the heating setpoint.

Electric Heat Interlock

The electric heat stages will be disabled (turned off) when the electric heat airflow is less than the defined minimum.



CAUTION:

Do not set EHEAT FLOW (the defined minimum) to less than 5%; otherwise, the electric heat interlock will be disabled.

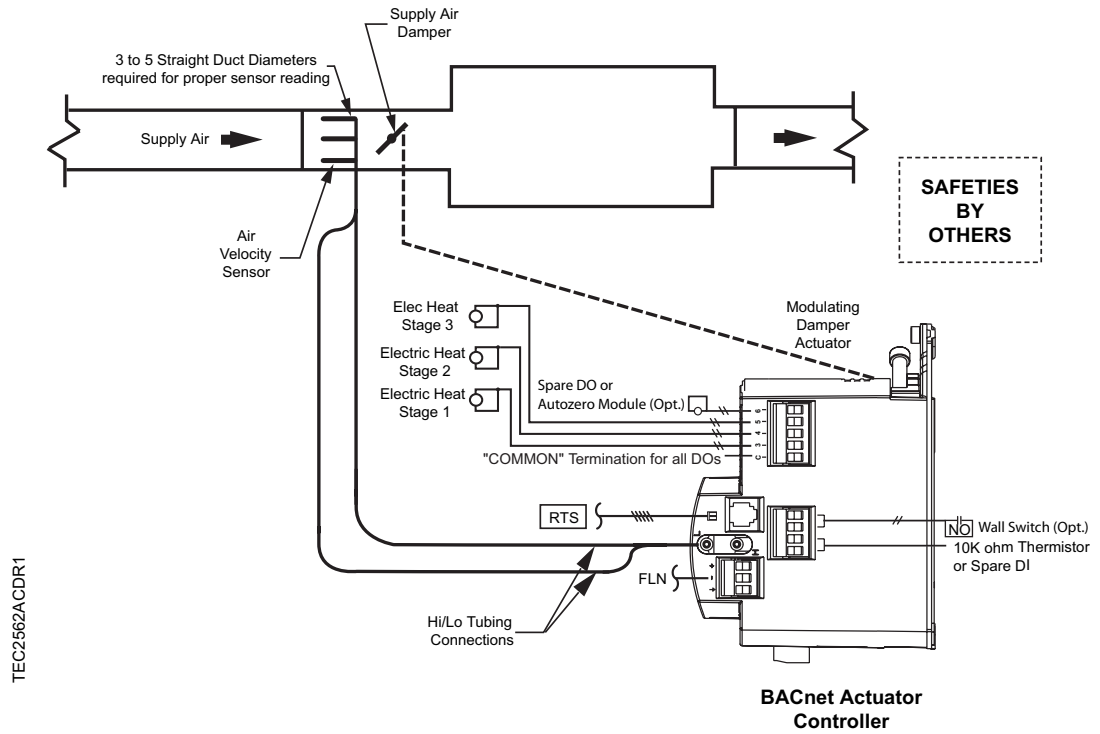

Figure 7. Application 2562 Control Drawing (Electric Heat).

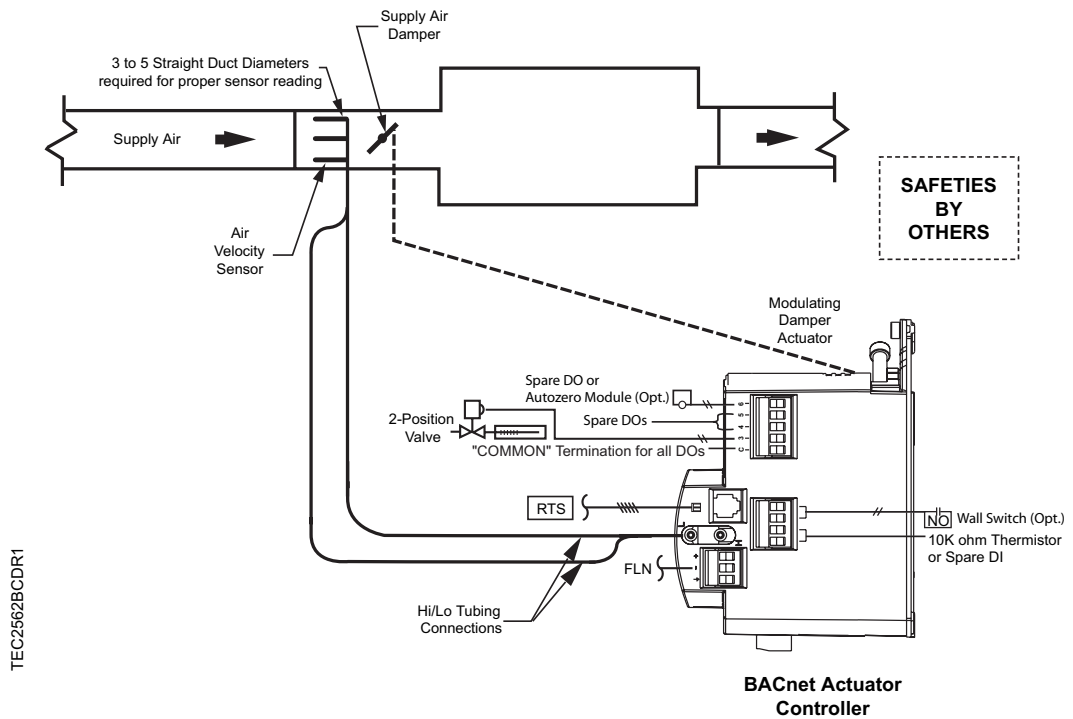

Figure 8. Application 2562 Control Diagram (Baseboard Radiation).

Application 2563 VAV with Hot Water Reheat

Overview

In Application 2563, the controller modulates the supply air damper of the terminal box for cooling and modulates a reheat valve (or valves) for heating. When in heating, the terminal box either maintains minimum airflow or modulates the supply air damper. In order for the terminal box to work properly, the central air handling unit must provide supply air. See Figure 9 and Figure 10.

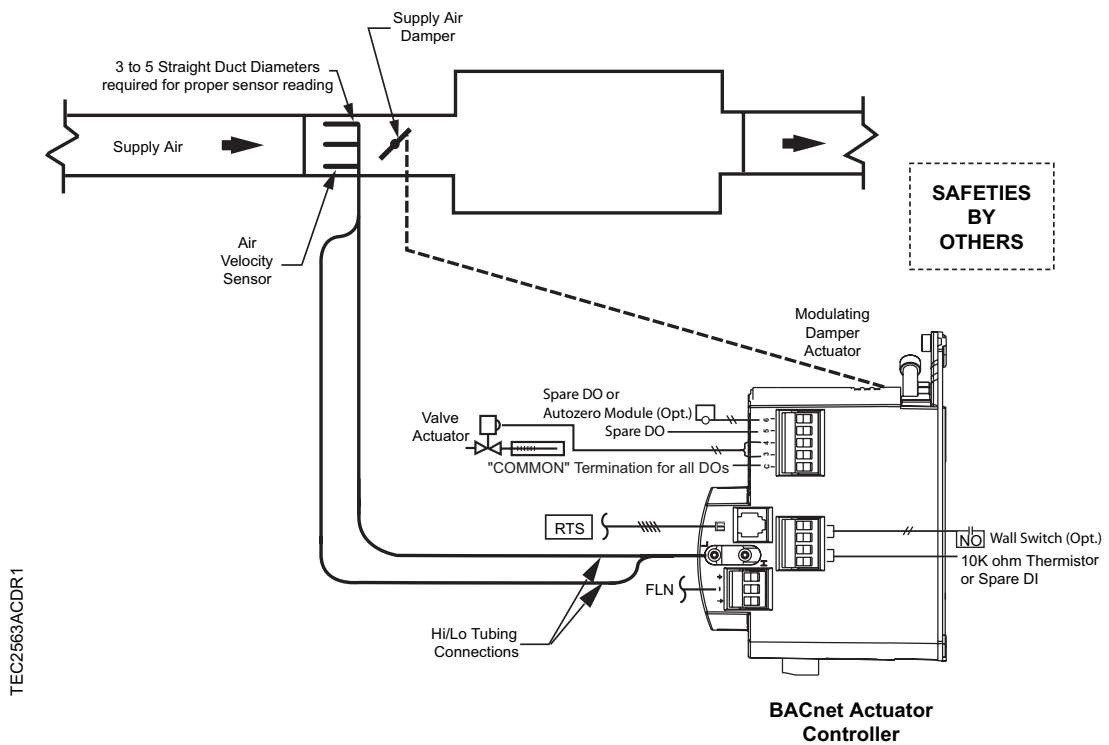

Figure 9. Application 2563 Control Drawing (HW Heat and Spare DO).

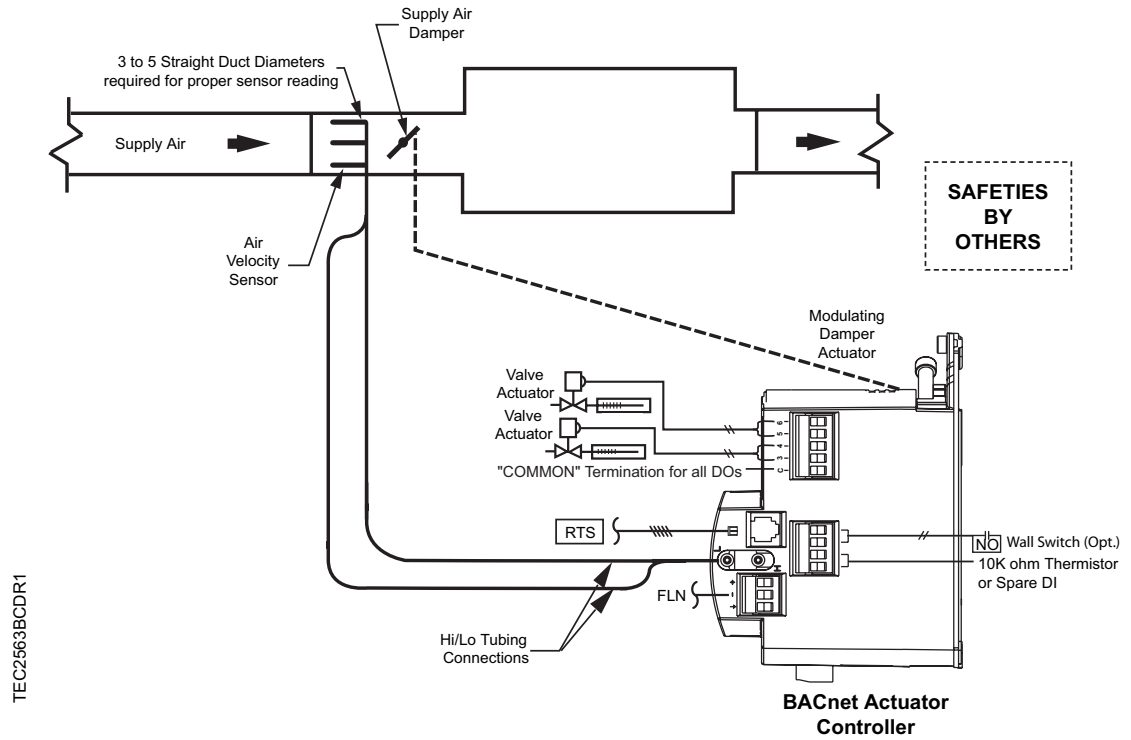

Figure 10. Application 2563 Control Drawing (Two Valve Actuators).

Application 2564 VAV Series Fan Powered with Electric Reheat

Overview

In Application 2564, the controller modulates the supply air damper of the terminal box for cooling and controls stages of electric reheat for heating. When in heating, the terminal box either maintains minimum airflow or modulates the supply air damper. The terminal box also has a series fan for air circulation. In order for the terminal box to work properly, the central air-handling unit must provide supply air. See Figure 11.

Fan Operation



CAUTION:

On series fan powered terminal boxes, the terminal box fan must be controlled/interlocked to start either before or at the same time as the central air handler. Failure to do so may cause the terminal box fan to rotate backwards and cause consequent damage at start up.

In day mode, the fan is ON all the time. In night mode, the fan cycles on when heating or cooling is required.

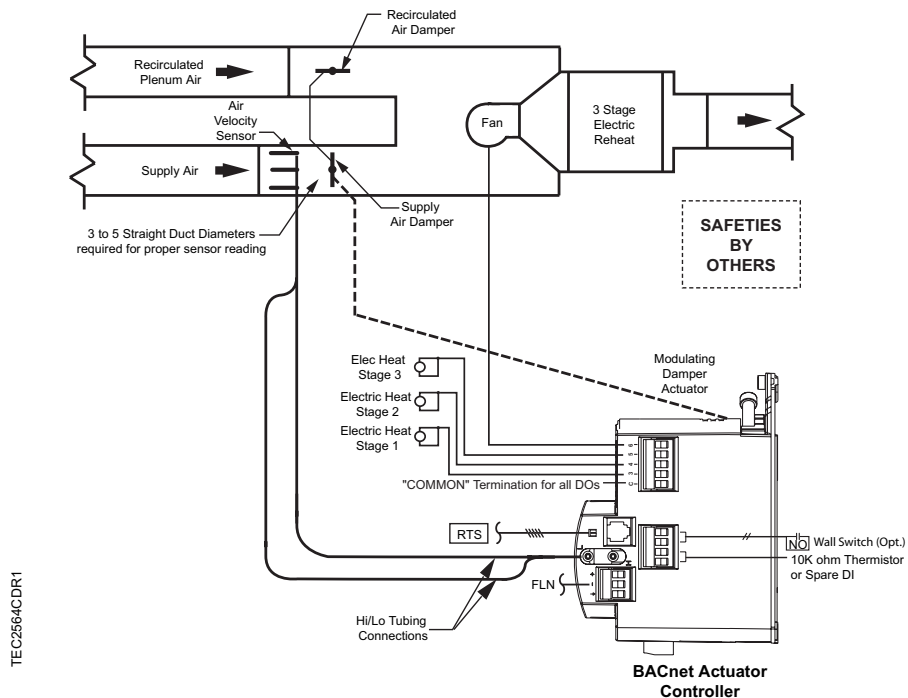

Figure 11. Application 2564 Control Drawing.

Application 2565 VAV Series Fan Powered with Hot Water Reheat

Overview

In Application 2565, the controller modulates the supply air damper of the terminal box for cooling and modulates a hot water valve for heating. When in heating, the terminal box either maintains minimum airflow or modulates the supply air damper. The terminal box also has a series fan for air circulation. In order for the terminal box to work properly, the central air handling unit must provide supply air. See Figure 12.

Fan Operation



CAUTION:

On series fan powered terminal boxes, the terminal box fan must be controlled/interlocked to start either before or at the same time as the central air handler. Failure to do so may cause the terminal box fan to rotate backwards and cause consequent damage at start up.

In day mode, the fan is ON all the time. In night mode, the fan cycles on when heating or cooling is required.

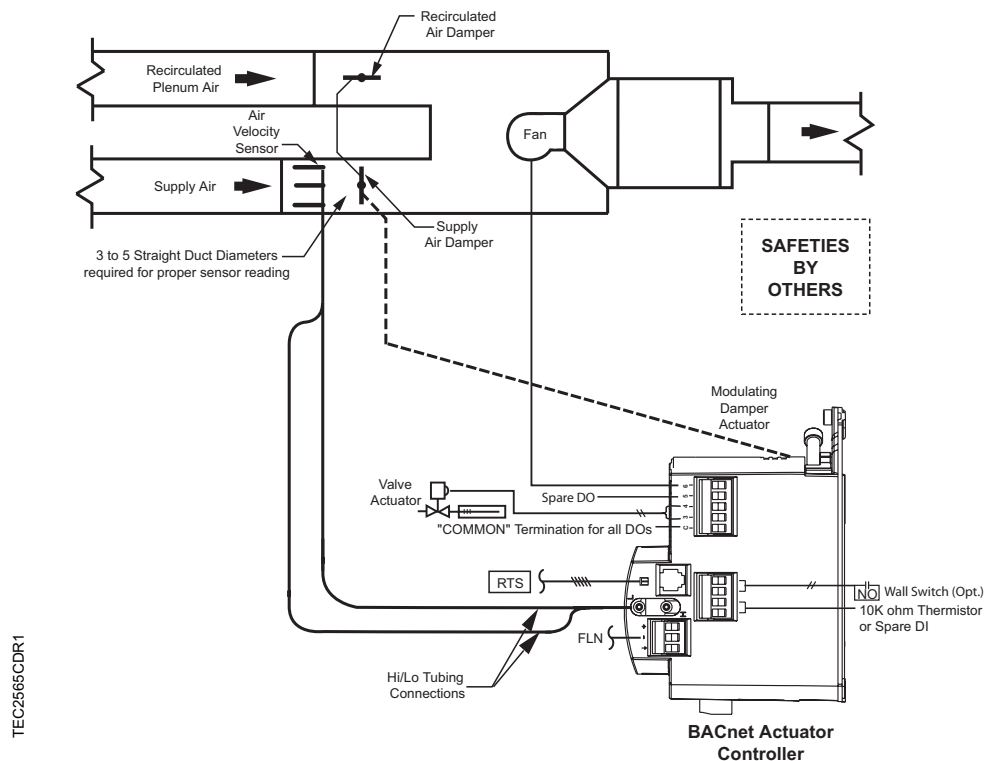

Figure 12. Application 2565 Control Drawing.

Application 2566 VAV Parallel Fan Powered with Electric Reheat

Overview

In Application 2566, the controller modulates the supply air damper of the terminal box for cooling and controls stages of electric reheat for heating. When in heating, the terminal box either maintains minimum airflow or modulates the supply air damper. The terminal box also has a parallel fan, which re-circulates the room air. In order for the terminal box to work properly, the central air handling unit must provide supply air. See Figure 13.

Fan Operation

The fan turns on when heating is required.

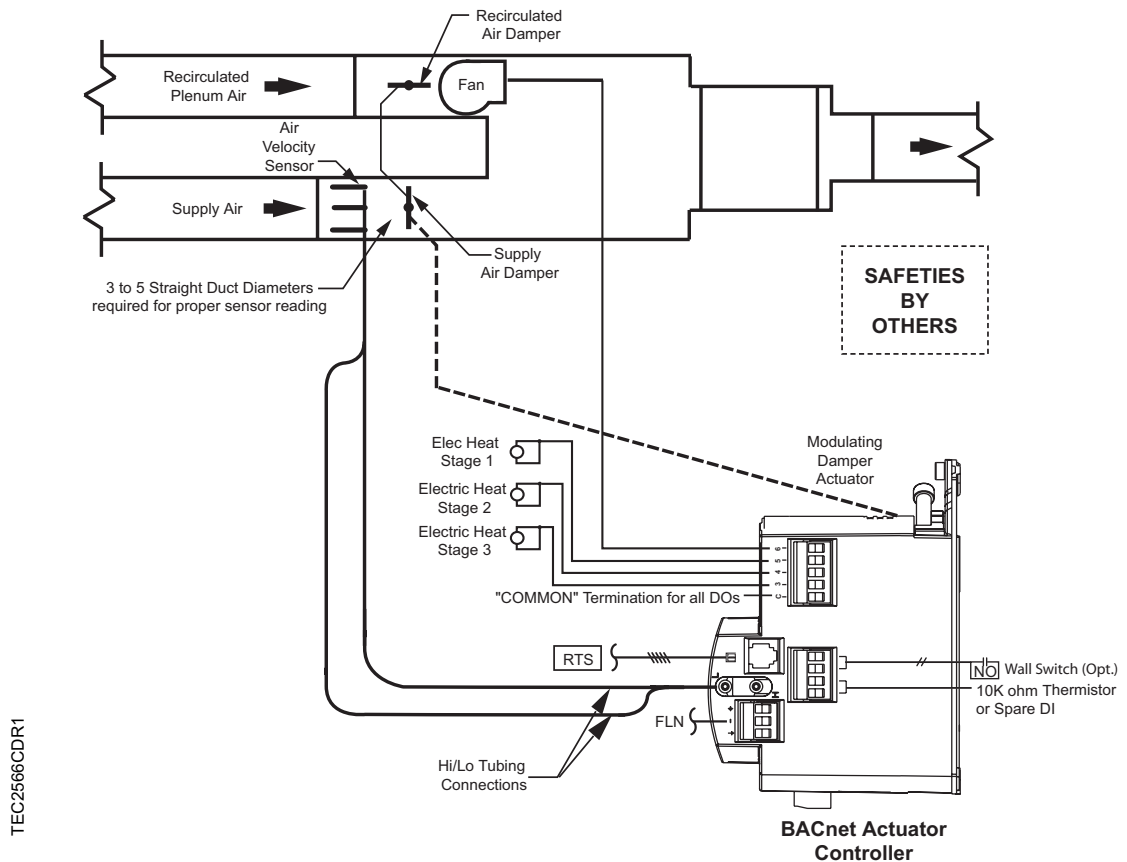

Figure 13. Application 2566 Control Drawing.

Application 2567 VAV Parallel Fan Powered with Hot Water Reheat

Overview

In Application 2567, the controller modulates the supply air damper of the terminal box to provide for cooling and modulates a hot water valve for heating. When in heating, the terminal box either maintains minimum airflow or modulates the supply air damper. The terminal box also has a parallel fan that re-circulates the room air. In order for the terminal box to work properly, the central air handling unit must provide supply air. See Figure 14.

Fan Operation

The fan turns on when heating is required.

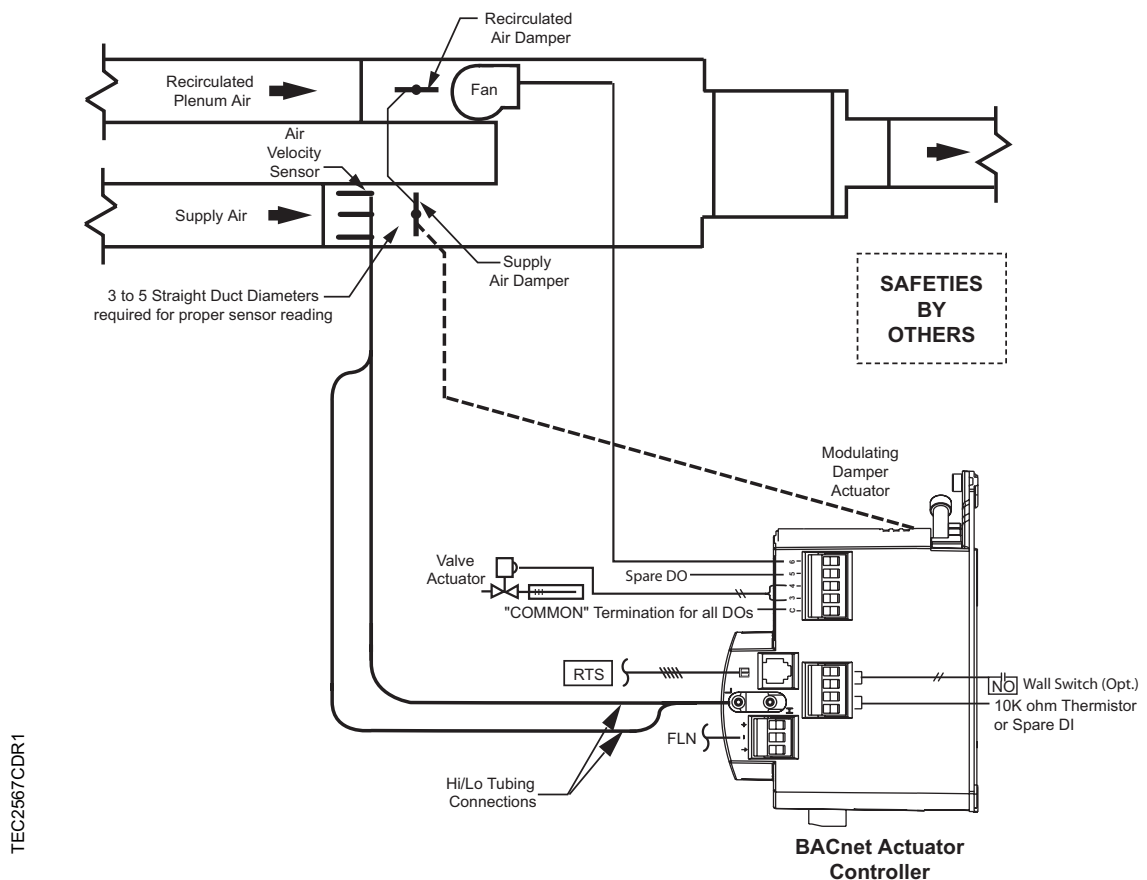

Figure 14. Application 2567 Control Drawing.

Application 2597 Slave Mode

Overview

Application 2597 is the slave mode application for the BACnet VAV Actuator (P/N 550-430 and 550-431). Slave mode is the default application that comes up when power is first applied to the controller. Slave mode provides no control. Its purpose is to allow the operator to perform equipment checkout before a control application is put into effect and to set some basic controller parameters (CTRL ADDRESS, APPLICATION, etc.). A controller in default state can also be used as a point extension device by unbundling spare I/O points at the field panel.

Using Auxiliary Points

It is possible to have extra points available on a BACnet VAV Controller — Electronic Output in addition to the ones used by the current application that is running in the controller. If these extra points are to be controlled by a field panel, then they must be unbundled at the field panel.

Using the Controller as a Point Extension Device

If the controller is only used as a point extension device, with no control application in affect, its application must be set to slave mode and points must be unbundled at the field panel. All points must be controlled from the field panel in order to be used.

DO 3, DO 4, DO 5, and DO 6 may be used as separate DOs or in pairs (DO 3 and DO 4, DO 5 and DO 6) to control a motor as shown in the example.

NOTE: If using either a motor or DOs as auxiliary points, be sure to set MTR SETUP to the correct value. If using a pair of DOs to control a motor, then the DOs cannot be unbundled. Only MTR1 COMD and MTR2 COMD can be unbundled to control the motors.

Example

If using DO 1 and DO 2 as the physical terminations for a motor, follow these steps:

1. Set MTR SETUP to 1 to enable the motor.
2. Unbundle MTR1 COMD at the field panel to command the motor from the field panel.

Contact your local Siemens Building Technologies, Inc. representative for other combinations of DOs and motors.

3

Point Database

Overview

Chapter 3 presents a description of the BACnet VAV Controller — Electronic Output point database, including point descriptors, point addresses, and a listing of applications in which each point is found.

Descriptor	Address ¹	Application	Description
CTLR ADDRESS	01	All	Identifies the controller on the FLN trunk.
APPLICATION	02	All	Identification number of the program running in the controller.
RMTMP OFFSET	03	All	Compensates for deviations between the value of ROOM TEMP and the actual room temperature. This corrected value is displayed in CTL TEMP. RMTMP OFFSET + ROOM TEMP = CTL TEMP
ROOM TEMP	{04} ²	All	Actual reading from the room temperature sensor.
HEAT.COOL	{05}	All except 2560, 2597	Current mode of operation for applications that can be in either a heating mode or a cooling mode.
DAY CLG STPT	06	All except 2597	The temperature setpoint in degrees that the controller maintains during day periods in cooling mode if a room temperature sensor setpoint dial is not present or is not used. See STPT DIAL.
NGT CLG STPT	08	All except 2597	The temperature setpoint in degrees that the controller maintains during the night periods in cooling mode.
DAY HTG STPT	07	All except 2560, 2597	The temperature setpoint in degrees that the controller maintains during day periods in heating mode if a room temperature sensor setpoint dial is not present or is not used. See STPT DIAL.
NGT HTG STPT	09	All except 2560, 2597	The temperature setpoint in degrees that the controller maintains during the night periods in heating mode.
RM STPT MIN	11	All except 2597	The minimum temperature setpoint in degrees that the controller can use from the setpoint dial. This overrides any temperature setpoint from the setpoint dial that falls below this minimum.

Descriptor	Address ¹	Application	Description
RM STPT MAX	12	All <i>except</i> 2597	The maximum temperature setpoint in degrees that the controller can use from the setpoint dial. This overrides any temperature setpoint from the setpoint dial that falls above this maximum.
RM STPT DIAL	{13} ²	All	The temperature setpoint in degrees from the room temperature sensor (not available on all temperature sensor models). This setpoint will be used for control in day mode (heating or cooling) when enabled by STPT DIAL.
STPT DIAL	14	All <i>except</i> 2597	YES indicates that there is a room setpoint dial on the room temperature sensor and it should be used as the temperature setpoint for control in day/occupied mode. NO indicates that the appropriate preset setpoint will be used as the temperature setpoint for control in day/occupied heating or cooling mode. Valid input: YES or NO.
AUX TEMP	{15}	All <i>except</i> 2561	Actual reading from a 10K Ω thermistor connected to the controller's AI 3 input. When a thermistor is connected at AI 3, DI 3 is not available. See DI 3.
SUPPLY TEMP	{15}	2561	Actual reading from a 10K Ω thermistor connected to the controller's AI 3 input. The controller uses this value to determine whether it is in heating or cooling mode.
FLOW START	16	All <i>except</i> 2560, 2561, 2597	Determines how the damper modulation will be sequenced while in heating mode. When HTG LOOPOUT is above this value, then FLOW STPT starts to increase.
FLOW END	17	All <i>except</i> 2560, 2561, 2597	Determines how the damper modulation will be sequenced while in heating mode. When HTG LOOPOUT is below this value, then FLOW STPT starts to decrease.
WALL SWITCH	18	All	YES indicates that the controller is to monitor the status of a wall switch that is connected to DI 2. NO indicates that the controller will not monitor the status of a wall switch, even if one is connected. Valid input: YES or NO.
DI OVRD SW	{19} ²	All	Actual indication of the status of the override switch (not physically available on all temperature sensor models) at the room temperature sensor. ON indicates that the switch is being pressed. OFF indicates that the switch is released. Valid input: ON or OFF.
OVRD TIME	20	All <i>except</i> 2597	The amount of time in hours that the controller will operate in day/occupied mode when the override switch is pressed while the controller is in night/unoccupied mode.

Descriptor	Address ¹	Application	Description
NGT OVRD	{21} ²	All <i>except</i> 2597	Indicates the mode that the controller is operating in with respect to the override switch. NIGHT indicates that the switch has not been pressed and the override timer is not active. DAY indicates that the switch has been pressed and the override timer is active. The controller then uses a day mode temperature setpoint. This point is only in effect when DAY.NGT indicates night mode.
REHEAT START	22	All <i>except</i> 2560, 2561, 2597	Determines how the reheat modulation will be sequenced while in heating mode. When HTG LOOPOUT is above this value, then the reheat modulates upward.
REHEAT END	23	All <i>except</i> 2560, 2561, 2597	Determines how the reheat modulation will be sequenced while in heating mode. When HTG LOOPOUT is below this value, then the reheat modulates downward.
DI 2	{24}	All	Actual status of a contact connected to the controller at DI 2. ON indicates that the contact is closed; OFF indicates that the contact is open. If a wall switch is used, it is connected to DI 2. See WALL SWITCH.
DI 3	{25} ²	All <i>except</i> 2561	Actual status of a contact connected to the controller at AI 3/DI 3. ON indicates that the contact is closed; OFF indicates that the contact is open. When a contact is connected at DI 3, AI 3 is not available. See AUX TEMP.
SERIES ON	26	2564, 2565	When flow rises above this value, the series fan will turn ON.
SERIES ON	26	2566	This point is present, but not used in this application.
SERIES OFF	27	2564, 2565	When flow drops below this value and other conditions have been met, the series fan will turn OFF.
SERIES OFF	27	2566	This point is present, but not used in this application.
PARALLEL ON	28	2564	This point is present, but not used in this application.
PARALLEL ON	28	2566, 2567	When flow drops below this value and other conditions have been met, the parallel fan will turn ON.
DAY.NGT	{29}	All	Indicates the mode in which the controller is operating. Day temperature setpoints will be used in day mode. Night temperature setpoints will be used in night mode. This point is normally set by the field panel.
PARALLEL OFF	30	2564	This point is present, but not used in this application.

Descriptor	Address ¹	Application	Description
PARALLEL OFF	30	2566, 2567	When flow rises above this value, the parallel fan will turn OFF.
CLG FLOW MIN	31	All <i>except</i> 2597	The minimum amount of air in CFM (LPS) to be supplied to the space in cooling mode.
CLG FLOW MAX	32	All <i>except</i> 2597	The maximum amount of air in CFM (LPS) to be supplied to the space in cooling mode.
HTG FLOW MIN	33	All <i>except</i> 2560, 2597	The minimum amount of air in CFM (LPS) to be supplied to the space in heating mode.
HTG FLOW MAX	34	All <i>except</i> 2560, 2597	The maximum amount of air in CFM (LPS) to be supplied to the space in heating mode.
AIR VOLUME	{35} ²	All	Actual amount of air in CFM (LPS) currently passing through the air velocity sensor.
FLOW COEFF	36	All	Calibration factor for the airflow sensor.
MTR3 COMD	{37}	2560, 2561, 2562, 2597	The value to which the Motor 3 actuator is commanded in percent of full value.
VLV2 COMD	{37}	2563	The value to which the valve 2 actuator is commanded in percent of full travel for applications using a second water valve.
MTR3 POS	{38}	2560, 2561, 2562, 2597	The current position of the Motor 3 actuator in percent of full travel. This value is calculated based on motor run time.
VLV2 POS	{38}	2563	The current position of Valve 2 in percent of full travel. This value is calculated based on valve run time.
MTR3 TIMING	39	All <i>except</i> 2564, 2565, 2566, 2567	The time required for the Motor 3 actuator to travel from the full closed position to the full open position.
DO 1	{41} ²	All	Digital output 1 controls a 24 Vac load with an ON or OFF status. If Motor 1 is enabled, DO 1 is coupled with DO 2 to control an actuator.
DO 2	{42}	All	Digital output 2 controls a 24 Vac load with an ON or OFF status. If Motor 1 is enabled, DO 2 is coupled with DO 1 to control an actuator.
DO 3	{43}	All <i>except</i> 2562, 2564, 2566	Digital output 3 controls a 24 Vac load with an ON or OFF status. If Motor 2 is enabled, DO 3 is coupled with DO 4 to control an actuator.
HEAT STAGE 1	{43}	2562, 2564, 2566	This point is DO 3 in applications with electric reheat. This digital output controls the contact for the first stage of heating and has a status of ON or OFF.

Descriptor	Address ¹	Application	Description
DO 4	{44}	All <i>except</i> 2562, 2564, 2566	Digital output 4 controls a 24 Vac load with an ON or OFF status. If Motor 2 is enabled, DO 4 is coupled with DO 3 to control an actuator.
HEAT STAGE 2	{44}	2562, 2564, 2566	This point is DO 4 in applications with electric reheat. This digital output controls the contact for the second stage of heating and has a status of ON or OFF.
DO 5	{45}	2560, 2561, 2563, 2597	Digital output 5 controls a 24 Vac load with an ON or OFF status. If Motor 3 is enabled, DO 5 is coupled with DO 6 to control an actuator.
DO 5	{45}	2565, 2567	Digital output 5 controls a 24 Vac load with an ON or OFF status.
HEAT STAGE 3	{45} ²	2562, 2564, 2566	This point is a digital output used to control the contact for the third stage of heating and has a status of ON or OFF.
DO 6	{46}	All <i>except</i> 2564, 2565, 2566, 2567	Digital output 6 controls a 24 Vac load with an ON or OFF status. If Motor 3 is enabled, DO 6 is coupled with DO 5 to control an actuator. In applications with CAL MODULE set to YES, this digital output controls the Autozero Module to calibrate the controller's internal air velocity transducer.
FAN	{46}	2564, 2565, 2566, 2567	This point is a digital output used to control the fan. ON indicates that the DO is energized; OFF indicates that the DO is de-energized.
DMPR COMD	{48}	All <i>except</i> 2597	The value to which the damper motor is commanded in percent of full travel.
MTR1 COMD	{48}	2597	The value to which the Motor 1 actuator is commanded in percent of full travel.
DMPR POS	{49}	All <i>except</i> 2597	The current position of the damper motor in percent of full travel. This value is calculated based on motor run time.
MTR1 POS	{49}	2597	The current position of Motor 1 in percent of full travel. This value is calculated based on motor run time. See MTR1 TIMING.
MTR1 TIMING	51	All	The time required for the Motor 1 actuator to travel from full closed to the full open position.
MTR2 COMD	{52} ²	2560, 2561, 2597	The value to which the Motor 2 actuator is commanded in percent of full travel (for use as an auxiliary slave point).
VLV COMD	{52}	2565, 2567	The value to which the valve actuator is commanded in percent of full travel for applications using a water valve.
VLV1 COMD	{52}	2563	The value to which the valve 1 actuator is commanded in percent of full travel for applications using a water valve.

Descriptor	Address ¹	Application	Description
MTR2 POS	{53}	2560, 2561, 2597	The current position of the Motor 2 actuator in percent of full travel (for use as an auxiliary slave point). This value is calculated based on motor run time. See MTR2 TIMING.
VLV POS	{53}	2565	The current position of the valve in percent of full travel for applications using a water valve. This value is calculated based on motor run time.
VLV1 POS	{53}	2563	The current position of valve 1 in percent of full travel for applications using a water valve. This value is calculated based on motor run time.
MTR2 TIMING	55	All except 2562, 2564, 2566	The time required for the Motor 2 actuator to travel from full closed to the full open position.
DMPR ROT ANG	56	All except 2597	The number of degrees the damper is free to travel.
DPR1 ROT ANG	56	2597	The number of degrees that damper 1 is free to travel.
DPR2 ROT ANG	57	2597	The number of degrees that damper 2, the hot duct damper, is free to travel.
MTR SETUP	58	All	The configuration setup code for Motors 1, 2, and 3. This enables the motors individually and sets each motor to be either direct or reverse acting. Note: When a motor is enabled, its associated DOs are enabled.
DO DIR.REV	59	All	The configuration setup code for DOs. Allows the DOs to be direct or reverse acting (enabled equals energized or disabled equals de-energized).
EHEAT FLOW	60	2562	The flow required before the electric heat will be enabled.
COOL TEMP	61	2561	The discharge air temperature where the controller will switch from heating to cooling mode. Used only in applications with SUPPLY TEMP.
HEAT TEMP	62	2561	The discharge air temperature where the controller will switch from cooling to heating mode. Used only in applications with SUPPLY TEMP.
CLG P GAIN	63	All except 2597	The proportional gain value for the cooling temperature control loop.
CLG I GAIN	64	All except 2597	The integral gain value for the cooling temperature control loop.
CLG D GAIN	65	All except 2597	The derivative gain value for the cooling temperature control loop.
CHK OUT	66	All	The procedure tests all of the necessary I/O and ensures the controller has the ability to operate within the set airflow range, between CLG FLOW MIN and CLG FLOW MAX.
HTG P GAIN	67	All except 2560, 2597	The proportional gain value for the heating temperature control loop.

Descriptor	Address ¹	Application	Description
HTG I GAIN	68	All <i>except</i> 2560, 2597	The integral gain value for the heating temperature control loop.
HTG D GAIN	69	All <i>except</i> 2560, 2597	The derivative gain value for the heating temperature control loop.
CHK STATUS	70	All	Displays the results of CHK OUT.
FLOW P GAIN	71	All <i>except</i> 2597	The proportional gain value for the flow control loop.
FLOW I GAIN	72	All <i>except</i> 2597	The integral gain value for the flow control loop.
FLOW D GAIN	73	All <i>except</i> 2597	The derivative gain value for the flow control loop.
FLOW BIAS	74	All <i>except</i> 2597	The biasing of the flow control loop.
FLOW	{75} ²	All <i>except</i> 2597	Indicates the actual amount of air currently passing the air velocity sensor. The value is calculated as a percentage based on where the value of AIR VOLUME is in the range between 0 and CTL FLOW MAX.
CTL FLOW MIN	{76} ²	All <i>except</i> 2597	The active minimum flow used as a limit for the flow control loop. This value is the same as CLG FLOW MIN if the controller is in cooling mode, or is the same as HTG FLOW MIN if the controller is in heating mode, unless it is overridden.
CTL FLOW MAX	{77}	All <i>except</i> 2597	The active maximum flow used as a limit for the flow control loop. This value is the same as CLG FLOW MAX if the controller is in cooling mode, or is the same as HTG FLOW MAX if the controller is in heating mode unless, it is overridden.
CTL TEMP	{78}	All <i>except</i> 2597	The temperature used as input for the temperature control loops. This value is the same as the value in ROOM TEMP and RM TEMP OFFSET unless it is overridden.
CLG LOOPOUT	{79}	All <i>except</i> 2597	The cooling temperature control loop output value in percent.
HTG LOOPOUT	{80}	All <i>except</i> 2560, 2597	The heating temperature control loop output value in percent.
AVG HEAT OUT	{81} ²	2562, 2564, 2566	This point is used to determine what stages of electric heat are used for a given loop output value. The ranges for the value are determined by the number of stages used: 0 to 100 for 1 stage of electric heat, 0 to 200 for 2 stages of electric heat, and 0 to 300 for 3 stages of electric heat. With electric heat, this value is equal to: HTG LOOPOUT × STAGE COUNT.
STAGE MAX	82	2562, 2564, 2566	The value, in percent, which the heating loop must exceed for the electric heat to be ON for the full duty cycle (STAGE TIME).
STAGE FAN	83	2565, 2567	The valve must be opened greater than this value before the fan will turn ON.

Descriptor	Address ¹	Application	Description
STAGE MIN	83	2562, 2564, 2566	The value, in percent, which the heating loop must go below for the electric heat to be OFF for the full duty cycle (STAGE TIME).
DMPR STATUS	{84} ²	2560, 2561, 2562, 2563	This point is used only when CAL MODULE set to YES. It readjusts the damper position if the command value is not equal to the actual position of the damper. CAL indicates that the damper is operating normally. RECAL indicates that the damper position was adjusted (recalibrated) by 25% because the desired airflow was not obtainable under its current status.
SWITCH LIMIT	85	All except 2560, 2561, 2597	The active temperature control loop output must be less than this value to switch between cooling mode and heating mode. Actual switchover depends on SWITCH DBAND being exceeded and is subject to SWITCH TIME being expired.
SWITCH TIME	86	All except 2560, 2561, 2597	The time, in minutes, before the heat/cool mode can change over when the other parameters are appropriate.
CAL MODULE	87	All except 2564, 2565, 2566, 2567	YES indicates that the Autozero Modules are enabled to calibrate the air velocity transducers. The dampers will not be used for calibration. NO indicates that Autozero Modules are disabled and that the air velocity transducers will be calibrated by closing the dampers. Valid input: YES or NO.
STAGE COUNT	88	2562, 2564, 2566	The number of electric heating stages used by the application. DOs associated with unused stages may be used as spare DOs.
VALVE COUNT	88	2563	The number of heating valves available.
STAGE TIME	89	2562, 2564, 2566	The cycle time in minutes for the electric reheat stages. For example, if there are three stages of electric heat and STAGE TIME = 10 minutes, STAGE COUNT = 3, and AVG HEAT OUT = 150% then, Stage 1 is ON for 10 minutes (100% of the time), Stage 2 is ON for 5 minutes (50% of 10 minutes) and OFF for 5 minutes, and Stage 3 is OFF.
SWITCH DBAND	90	All except 2560, 2561, 2597	The temperature range in degrees which is compared to the difference between CTL TEMP and CTL STPT. The difference must exceed this value for temperature control mode to change over. Changeover is also subject to the active temperature control loop output being below SWITCH LIMIT (Point 85) and SWITCH TIME being expired.
CTL STPT	{92}	All except 2597	The actual setpoint value being used as input for the active temperature control loop.
FLOW STPT	{93}	All except 2597	The setpoint of the flow control loop.

Descriptor	Address ¹	Application	Description
CAL AIR	{94}	All	YES commands the controller to go through calibration sequence for the air velocity transducers. YES is also displayed when the calibration sequence is started automatically. CAL AIR automatically returns to NO after the calibration sequence is completed. Valid input: YES or NO.
CAL SETUP	95	All	The configuration setup code for the calibration sequence options.
CAL TIMER	96	All	Time interval, in hours, between the calibration sequence initiations if a timed calibration option is selected in CAL SETUP.
DUCT AREA	97	All	Area, in square feet (square meters), of the duct where the air velocity sensor is located. This is a calculated value (calculated by the field panel or computer being used) that depends on duct shape and size. It is used in calculating all points in units of CFM, CF, LPS and L. Valid input: .025 ft ² (.002 m ²) through 6.375 ft ² (.5923 m ²).
LOOP TIME	98	All <i>except</i> 2597	The time, in seconds, between control loop calculations.
ERROR STATUS	{99} ²	All	The status code indicating any errors detected during controller power up. A status of 0 indicates there are no problems.

1. Points not listed are not used in this application.
2. Point numbers that appear in brackets { } may be unbundled at the field panel.

4

Troubleshooting

This chapter describes corrective measures you can take should you encounter a problem when using a BACnet VAV Actuator.

You are not required to do any controller troubleshooting. You may want to contact your local Siemens Building Technologies representative if a problem occurs or you have any questions about the controller.

NOTE: When troubleshooting, record what the problem is and what actions were performed immediately before the problem occurred. Being able to describe the problem in detail is important, should you need assistance from your local Siemens Building Technologies representative.

Basic Service Information

Always remove power to the VAV Actuator when installing or replacing it. Since the controller does not have a power switch, the recommended method of removing power to a locally powered controller is to turn OFF the power to the 24 Vac transformer. The recommended method of removing power to a controller on a power cable (even to service a single controller) is to turn OFF the power at the transformer.

NOTE: When removing power to a controller to perform maintenance or service, make sure that the person in charge of the facility is aware of this and that appropriate steps are taken to keep the building in control.

Never remove the cover from the VAV Actuator. There are no serviceable parts inside. If a problem is found with this device, contact your local Siemens Building Technologies representative for replacement. An anti-static wrist strap is recommended when installing or replacing controllers.

Preventive Maintenance

Most controller components are designed so that, under normal circumstances, they do not require preventive maintenance. Periodic inspections, voltage checks, and point checks are normally not required. The rugged design makes most preventive maintenance unnecessary. However, devices that are exposed to dusty or dirty environments may require periodic cleaning to function properly.

Safety Features

The controller board stores the controller's address, applications, and point values. In the event of a power failure or a reset, these values are retrieved from the controller's permanent memory and are used by the controller unless overridden by a field panel. If one of the following conditions occurs, the controller will activate safety features present in its fail-safe mode.

- Sensor failure.
- Loss of power. Upon controller power loss, communication with the controller is also lost. The controller will appear as failed (*F*) at the field panel.

Controller LEDs

To determine if the controller is powered up and working, verify that the Basic Sanity Test (BST) Light Emitting Diode (LED) is flashing ON/OFF once per second. The controller contains seven LEDs located on the circuit board. See the *Controller LED Indicators* section of *Chapter 1, Product Overview* for more information about LEDs.

NOTE: The TX and RX LEDs indicate communication over the FLN.

Automated Checkout

The BACnet VAV Actuator has a built-in checkout procedure that can be manually initiated at any time after the controller has been installed. The procedure tests all of the necessary I/O and ensures the controller has the ability to operate within the set airflow range, between CLG FLOW MIN and CLG FLOW MAX.

To perform the checkout procedure, set CHK OUT to **YES**. When the procedure is completed, CHK OUT returns to NO and the results are displayed in CHK STATUS. See Table 3.

Table 3. Possible Failure Value and Description.

CHK STATUS Values	Description
-1	Checkout procedure has not been run since last controller initialization.
0	No errors found.
1	Room temperature sensor failed.
2	Room setpoint dial failed [If STPT DIAL is set to YES].
4	Air velocity sensor failed.
8	Controller could not reach CLG FLOW MIN or below.
16	Controller could not reach CLG FLOW MAX or above.

NOTE: Multiple failures are added together and displayed as one value. For example, if the room temperature sensor failed (1) and the controller could not reach CLG FLOW MAX, CHK STATUS displays 17.

Failure codes indicate the following possible problems.

Room temperature sensor failed—CHK STATUS = 1

1. The cable for the room temperature sensor may be unplugged or loose. Check both ends to ensure that the cable is securely seated.
2. Connect directly to the controller through the room temperature sensor connection on the BACnet VAV Actuator and check whether communication is possible. If so, the problem lies in the room temperature sensor or its cable. If not, the problem is with the controller.
3. Contact your local Siemens Building Technologies representative.

Room setpoint dial failed—CHK STATUS = 2

1. The cable for the room temperature sensor may be unplugged or loose. Check both ends to ensure that the cable is securely seated.
2. The controller may be incorrectly set to use a setpoint dial with a sensor that does not have the dial. If the sensor has no dial, change STPT DIAL (Point 14) from **YES** to **NO**.
3. Connect directly to the controller through the room temperature sensor connection on the BACnet VAV Actuator and check whether communication is possible. If so, the problem lies in the room temperature sensor or its cable. If not, the problem is with the controller.
4. Contact your local Siemens Building Technologies representative.

Air velocity sensor failed—CHK STATUS = 4

1. The sensor tubing may be blocked, leaking, or disconnected. Check for pinched, disconnected, or cracked sensor tubing. Correct as needed.
2. The tubing connections for the air velocity sensor may be reversed. Repipe if HI and LO connections are incorrect.

The sensor or the BACnet VAV Actuator may be faulty.

Controller could not reach CLG FLOW MIN or below—CHK STATUS = 8

1. The actuator may be loose on the shaft. Check that the setscrew is fully tightened against the damper shaft. Follow these torque guidelines:
 - 70 ± 5 inch pounds—solid metal
 - 37 ± 2 inch pounds—plastic, graphite, composite, or hollow metal (Hollow metal shafts require an insert to prevent shaft damage.)
2. The tubing for the air velocity sensor may be pinched, disconnected, or cracked. Check the tubing and correct as needed.
3. The tubing connections for the air velocity sensor may be reversed. Repipe if HI and LO connections are incorrect.

4. Box sizing information may be incorrect. Check the values of the following points and correct as needed:
 - DUCT AREA
 - FLOW COEFF
 - CLG FLOW MIN
 - CLG FLOW MAX
5. Motor setup information may be incorrect. Check the values of the following points and correct as needed:
 - MTR SETUP
 - MTR1 TIMING
 - DMPR ROT ANG
6. The box may not have been balanced correctly. Contact your local Siemens Building Technologies Representative.
7. The air velocity sensor may need calibration. Set CAL AIR to **YES** to run the calibration sequence. When CAL AIR returns to NO, indicating that the sequence is finished, run the checkout procedure again to see whether the problem has been corrected.

Controller could not reach CLG FLOW MAX or above—CHK STATUS = 16

1. Check for the problems described immediately above for CLG FLOW MIN.
2. The box may be starved for air, either because the central air-handling unit is off or because of low duct static.

Glossary

Overview

The glossary contains terms and acronyms that are used in this manual. For definitions of point database descriptors, see Chapter 3, *Point Database*, in this manual.

AI

Analog Input. A point receiving a signal that represents a condition that has more than two states. For example, flow rate sensors (water or air), temperature sensors (room or duct), pressure sensors (static or velocity), and humidity sensors (room, duct, or outdoor).

airflow

Rate at which a volume of air moves through a duct. Usually expressed in cubic feet per minute (cfm) or liters per second (lps).

algorithm

Mathematical formula that uses varying inputs to calculate an output value.

AVS

Air Velocity Sensor.

AZM

Autozero Module. Equipment controller device used to calibrate the Variable Air Volume Controller's internal air velocity transducer without changing the volume of air being delivered to a space.

centralized control

Type of control offered by a controller that is connected by means of Field Level Network (FLN).

cfm

Cubic Feet per Minute.

control loop

PID algorithm that is used to control an output that is based on a setpoint and an input reading from a sensor.

DDC

Direct Digital Control.

DI

Digital Input. Physical input point that receives a two-state signal (ON/OFF, OPEN/CLOSED, YES/NO).

DO

Digital Output. Physical output point that sends a two-state signal (ON/OFF, OPEN/CLOSED, YES/NO).

English units

The foot-pound-second system of units for weights and measurements.

equipment controller

FLN device that provides additional point capacity to a field panel or provides individual room or mechanical equipment control.

field panel

A device containing a microprocessor for centralized control of system components and equipment controllers.

FLN

Field Level Network. Network consisting of equipment controllers, FLN end devices, fume hoods, etc.

lps

Liters per Second.

loopout

Output of the control loop expressed as a percentage.

HMI

Human Machine Interface. Terminal and its interface program that allows you to communicate with a field panel or equipment controller.

override switch

Button on a room temperature sensor that an occupant can press to change the status of a room from unoccupied to occupied (or from night to day) for a predetermined time.

pressure independent

Variable Air Volume (VAV) room temperature control system in which the temperature drives an airflow setpoint.

PID

Proportional, Integral, Derivative.

RTS

Room Temperature Sensor.

setpoint

Virtual point that stores a point value such as a temperature setting. Points that monitor inputs, such as temperature, report actual values.

SI units

Système International d'Unités. The international metric system.

slave mode

Default application that displays when power is first applied to an equipment controller. No control action is initiated in the slave mode.

stand-alone control

Type of control offered by a controller that is providing independent DDC control to a space.

Terminal Equipment Controller

Siemens Building Technologies, Inc. product family of equipment controllers (one is the BACnet VAV Controller - Electronic Output) that house the applications software used to control terminal units, such as heat pumps, VAV terminal boxes, fan coil units, unit ventilators, etc.

unbundle

Term used to describe the entering of a point that resides in a controller's database into the field panel's database so that it can be monitored and controlled from the field panel.

VAV

Variable air volume. Ventilation system that changes the amount of air supplied to and exhausted from the rooms served.

Index

A

air velocity sensor	
failure code	30
troubleshooting	31
Air Velocity Sensor (AVS)	2
algorithm	33
application 2560	
control drawing	9
overview	9
application 2561	
control drawing	10
overview	10
application 2562	
baseboard radiation.....	1, 11, 12
control drawing	12
electric heat	12
electric heat interlock.....	11
overview	11
application 2563	
control drawing	13, 14
hot water heat and spare DO	13
overview	13
two valve actuators.....	14
application 2564	
control drawing	15
overview	15
Application 2564	
fan operation.....	15
application 2565	
control drawing	16
overview	16
Application 2565	
fan operation.....	16
application 2566	
control drawing	17
fan operation.....	17
overview	17
application 2567	
control drawing	18
overview	18
Application 2567	
fan operation.....	18
Application 2597	
overview	19

using auxiliary points.....	19
using controller as point extension device ...	19
applications	
calibration	7, 23
control loops	6
control temperature setpoints	6
damper status operation	7
day/night mode.....	6
electric reheat	
stage 1	1, 8, 15, 17
stage 2	1, 8, 15, 17
stage 3	1, 8, 15, 17
fail-safe operation.....	7
heating and cooling switchover.....	7
hot water reheat	1, 8, 13, 16, 18
modulate damper during heating mode	7
night mode override switch	6
notes.....	1, 8
sequencing logic	6

B

Basic Sanity Test (BST).....	30
basic service information	29
BST LED	30

C

centralized control.....	33
checkout procedure	30
CHK OUT (Point 10)	30
CHK STATUS (Point 3)	30
communication wiring	4
control loop	34
controller	
LEDs/LED indicators	30

D

damper	
troubleshooting.....	31, 32
DDC	34
DI	34

Direct Digital Control (DDC).....1, 6
 DO.....34

E

English units.....34
 equipment controller.....34, 36

F

failure codes).....30
 fan 1, 3, 15, 16, 17, 18
 FLN.....34
 Floor Level Network (FLN).....4

H

hardware
 autozero module.....3, 7
 failure codes30
 fan..... 1, 3, 15, 16, 17, 18
 LEDs.....4
 power wiring3
 relay module5
 temperature sensors4

L

Light Emitting Diodes (LEDs).....30
 BST.....30
 RX and TX.....30
 loopout.....34

O

override switch35

P

PID35
 point database
 overview20
 power wiring3
 preventive maintenance29

R

related equipment5
 relay module5
 room temperature sensor
 failure code.....30
 troubleshooting.....31
 RTS.....35
 RX LED30

S

safety features30
 service information, basic29
 setpoint dial
 failure code.....30
 troubleshooting.....31
 SI units35
 stand-alone control35
 static discharge29

T

temperature sensors
 duct temperature sensor4
 RTS4
 troubleshooting29
 basic service information.....29
 TX LED30

U

units, English.....34

V

valve
 2-position heating3, 7, 23

W

wiring
 communication wiring.....4
 power wiring3