

HK6800
HK6900

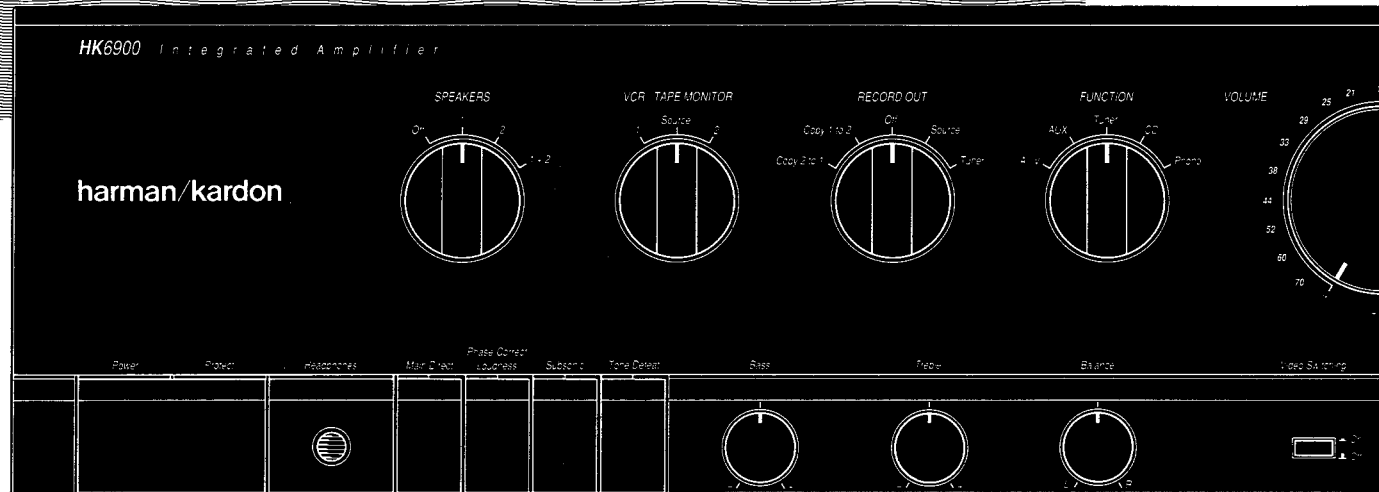

Integrated Amplifier Instruction Manual

harman/kardon

HK6800 and HK6900 Features

Thank you for choosing a Harman Kardon integrated amplifier. This is a superb piece of high fidelity equipment that has been meticulously designed to provide you with thousands of hours of enjoyment.

This manual describes the features and capabilities of your new integrated amplifier. In addition, it describes the proper method for connecting your integrated amplifier to your system. Please read this owner's manual and use your integrated amplifier only in accordance with its instructions. Keep the manual in a safe place for future reference.

Discrete circuitry

Rather than employing simple integrated circuits in the amplifier section, the HK6800 and HK6900 use completely discrete (separate) electronic components for greatly improved linearity and less distortion.

HCC (High-instantaneous Current Capability)

While reproducing dynamic music signals, the instantaneous impedances of nearly all loudspeakers drop to less than a third of the nominal rating. These low instantaneous impedances typically require three to six times more current from the amplifier than a nominal 8 ohm resistive load requires. The HK6800 and HK6900 integrated amplifiers can provide respectively 70 and 90 amperes of instantaneous current, which ensures that your speakers will be able to continually reproduce the entire dynamic range.

Ultrawide bandwidth

Unlike ordinary integrated amplifiers, the HK6800 and HK6900 can reproduce musical frequencies ranging from less than 10Hz to more than 100kHz. This ultrawide bandwidth improves the accuracy of reproduction of transient signals and ensures phase linearity.

Low negative feedback

This design philosophy is used by the world's most exclusive amplifiers. It requires the highest quality internal components, and results in an extremely stable amplifier with unmeasurable TIM distortion and absolutely outstanding imaging characteristics.

Main direct

The MAIN DIRECT switch routes the source signal directly to the input of the amplifier, bypassing all tone controls and other preamplifier circuitry. The signal is therefore attenuated only by the high-quality volume control, resulting in very pure sound quality.

Tone defeat

The TONE DEFEAT switch causes the source signal to completely bypass the tone control circuitry. This results in unaltered, completely accurate musical reproduction.

Video preamplifier switch

In keeping with Harman Kardon's emphasis on quality, the HK6800 and HK6900 incorporate a switch that enables you to turn off the internal video preamplifier for the purest possible sound quality.

Electronic function switching

The controls on the front panel of the HK6800 and HK6900 switch input and output connections electronically through the use of high fidelity electronic analog switches. Harman Kardon's simple and elegant electronic design makes possible complex component configurations. In addition, this all-electronic circuitry ensures that the switches will function quietly and reliably for the life of the unit.

High voltage/high current design

Harman Kardon has designed the HK6800 and HK6900 to be able to handle low impedances and unstable speaker loads that would destroy less rugged amplifiers. While the HK6800 and HK6900 can easily manage these loads, the unit can be set to provide higher voltage and even more power into higher impedance loudspeakers, allowing you to use the unit to full capacity.

Phase-correct loudness contour

Harman Kardon's exclusive Phase-correct loudness circuitry provides a special fixed equalization curve that compensates for the ear's decreased sensitivity at low volumes. This special circuitry is unusual in that it corrects for midrange phase errors inherent in low frequency loudness equalization. The result of this correction is that low frequencies sound clear and natural, with no coloration or degradation of stereo imaging.

Active/passive phono section with MM and MC inputs

A switch on the front panel of the HK6800 and HK6900 sets up the gain and input impedance of your amplifier's internal circuitry to match the type of cartridge being used on your turntable. The HK6800 and HK6900 provide you with both a passive (unamplified) phono section for use with standard moving magnet phono cartridges, and an active (amplified) phono section for use with moving coil (low output) phono cartridges. You can connect both moving coil and moving magnet cartridge inputs and use the switch on the front panel to select between them.

Pre-out connectors

The PRE-OUT connectors on the rear panel allow you to use the preamplifier section independently. You could connect your HK6800/HK6900 to an external power amplifier and use your HK6800/HK6900 as a preamplifier only. Or you could connect an external amplifier to your HK6800/HK6900 and simultaneously use the power amplifier section of your HK6800/HK6900.

HK6800 and HK6900 Basics

Placement

The HK6800 and HK6900 are fully shielded and may be placed on top of or under other stereo components as long as the "feet" provide sufficient clearance for cooling for the component below. Please make sure that the HK6800 or HK6900 receives adequate ventilation. It should always be located away from heat sources such as radiators, fireplaces, stoves, and other appliances that produce heat. Avoid placing the unit in locations that receive prolonged direct sunlight or extremely low temperatures.

Power source

The HK6800 or HK6900 should be connected *only* to a 120 volt, 60 cycle power supply.

Power cord protection

The power cord should be routed in such a way that it is not likely to be walked on or pinched by items laying on or against it. Any power cord is susceptible to stress at the point where it joins the plug and the point where it exits from the back of the unit, so take care not to fold or bend it excessively at those points. Never pull or stretch the cord. The amplifier's power cord should be unplugged from the outlet when the unit is left unused for a long period of time.

Cleaning

Use only a clean dry cloth to clean your amplifier. Do not use solvents such as alcohol, benzine, gasoline, etc. Take care that excessive dust does not accumulate on your unit, and that objects are not dropped inside or liquids spilled into the unit.

Water and moisture

Do not operate this amplifier around water (e.g., near a swimming pool, sink, or in a wet basement).

Abnormal smells

If you detect an abnormal smell or smoke, immediately turn the amplifier off and unplug the power cord. Contact your dealer or nearest Harman Kardon service center.

Service

Your amplifier should be serviced by authorized Harman Kardon service personnel when:

- The plug or power cord has been damaged.
- Objects have fallen into the unit.
- Liquid has been spilled into the unit.
- The unit has been exposed to rain.
- The unit does not operate normally.
- The unit has been dropped or the cabinet has been damaged.

Please do not attempt to service your amplifier beyond the troubleshooting suggestions in this manual. All other service should be referred to authorized Harman Kardon service personnel.

Packing material

Your box and packing material are custom-designed to provide optimum protection for your amplifier. Be sure to save the box and packing material in case you need to transport or ship the unit at some time.

Warranty card

Fill out the warranty card and save your sales receipt. Your sales receipt is your proof of purchase and you may need it to establish the date on which your warranty begins. You will be required to show it for service during the duration of Limited Warranty.



CAUTION
RISK OF ELECTRIC SHOCK
DO NOT OPEN



CAUTION: TO REDUCE THE RISK OF ELECTRIC SHOCK, DO NOT REMOVE COVER (OR BACK). NO USER SERVICEABLE PARTS INSIDE. REFER SERVICING TO QUALIFIED SERVICE PERSONNEL.



The lightning flash with arrowhead symbol, within an equilateral triangle, is intended to alert the user to the presence of uninsulated "dangerous voltage" within the product's enclosure that may be of sufficient magnitude to constitute a risk of electric shock to persons.



The exclamation point within an equilateral triangle is intended to alert the user to the presence of important operating and maintenance (servicing) instructions in the literature accompanying the appliance.

WARNING: TO REDUCE THE RISK OF FIRE OR ELECTRIC SHOCK, DO NOT EXPOSE THIS APPLIANCE TO RAIN OR MOISTURE.

CAUTION: TO PREVENT ELECTRIC SHOCK, DO NOT USE THIS (POLARIZED) PLUG WITH AN EXTENSION CORD, RECEPTACLE OR OTHER OUTLET UNLESS THE BLADES CAN BE FULLY INSERTED TO PREVENT BLADE EXPOSURE.

ATTENTION: POUR PREVENIR LES CHOCS ELECTRIQUES NE PAS UTILISER CETTE FICHE POLARISEE AVEC UN PROLONGATEUR, UNE PRISE DE COURANT OU UNE AUTRE SORTIE DE COURANT, SAUF SI LES LAMES PEUVENT ETRE INSEREES A FOND SANS EN LAISSER AUCUNE PARTIE A DECOUVERT.

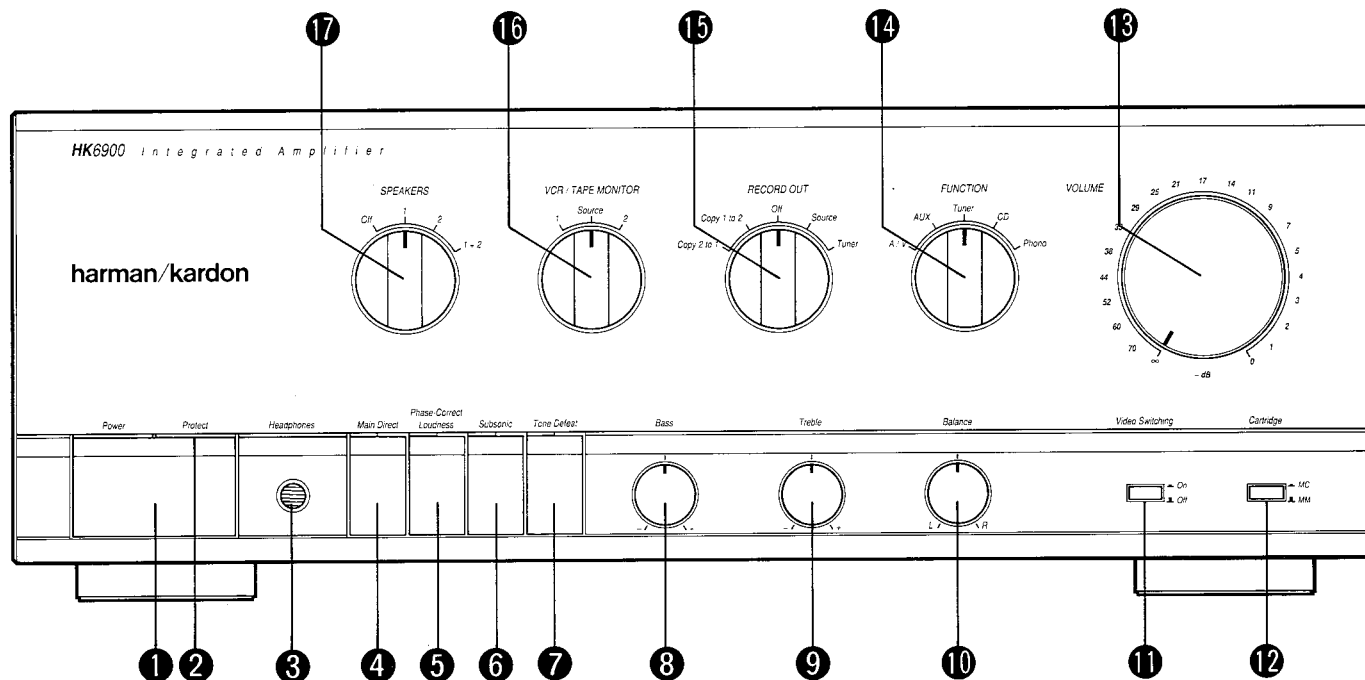

1 POWER switch

The POWER switch turns the unit on and off. In North American and Japanese versions, this switch also controls power to the SWITCHED outlets on the back of the unit. When the power to the unit is off, the switched outlets are also turned off.

2 PROTECT light

This light indicates that the protection circuitry of your amplifier is engaged. The light will come on under two circumstances:

- When you turn the unit on. As the unit prepares itself for operation, a muting circuit temporarily prevents pops or other noise from reaching your speakers. When the unit is ready for operation (in approximately 10 seconds), the light will go off.
- When the unit detects a problem. This light will come on if your speakers wires are touching, causing a short circuit, or if your amplifier overheats. In the case of overheating, a thermal sensor will shut down the unit

before damage can occur. Depending on the cause and extent of the overheating, the unit may take some time to cool down, and the protection circuit will remain in operation until the unit is cool enough to operate safely. In the case of a short circuit in the speaker wires, the protection circuitry will attempt to reset itself every 10 seconds, and you may hear a slight click as it does so. The protection circuit will remain in operation until the condition is corrected.

3 HEADPHONE jack

Stereo headphones with a standard 1/4" plug can be connected to this jack. You can listen to headphones regardless of whether your speakers are playing. To listen to headphones only, turn the speaker selector to "OFF."

4 MAIN DIRECT

When the MAIN DIRECT switch is on, the source signal goes directly to the input of the amplifier, bypassing all tone controls and other preamplifier circuitry and is attenuated

only by the volume control. The indicator light will be lit when the MAIN DIRECT switch is on.

5 PHASE-CORRECT LOUDNESS

At low volume levels, your ear is less sensitive to very low bass frequencies than it is at normal listening levels. The loudness button provides a special equalization curve that boosts low frequencies. The loudness button is useful for restoring full frequency balance at low volume levels, and can also be used to improve the bass response of small bookshelf speakers. The indicator light will be lit when PHASE CORRECT LOUDNESS is on.

6 SUBSONIC filter

Warped records and turntable resonance can generate sub-audible frequencies that can cause your speaker's woofer cones to visibly flutter. This very low frequency noise, while inaudible, can rob power from your amplifier, can cause feedback through your turntable, can cause intermodulation distortion at audible frequencies, and can actually damage your woofers if the movement is violent

enough. The subsonic filter reduces these inaudible frequencies at 6dB per octave below 15Hz. The audible portion of the frequency range will not be affected, so it is useful to leave the subsonic filter on at all times when listening to the turntable. The indicator light will be lit when the SUBSONIC filter is on.

7 TONE DEFEAT switch

When TONE DEFEAT is turned on, the bass and treble controls have no effect. The TONE DEFEAT switch internally bypasses the tone control circuitry, resulting in completely unaltered frequency response. If you want to use the bass and treble controls, turn TONE DEFEAT off. The indicator light will be lit when the TONE DEFEAT switch is on.

8 BASS control

The BASS control boosts or reduces the low frequency sound level. The BASS control affects only frequencies below 300Hz, and allows changes of up to ± 10 dB. The BASS tone control, in some circumstances, can help you adjust the overall sound of your system. For example, "boomy" room acoustics may be improved with a slight decrease in the bass, or the sound of smaller loudspeakers lacking in bass may be improved with a bass boost.

9 TREBLE control

The TREBLE control boosts or reduces the high frequency sound level. The TREBLE control affects only frequencies above 3000Hz, and allows changes of up to ± 10 dB. The TREBLE tone control, in some circumstances, can help you adjust the overall sound of your system. For example, an overly shrill recording or "bright" room acoustics may be improved by a reduction in the amount of treble.

10 BALANCE CONTROL

The BALANCE control distributes the sound between the right and left speakers. For equal balance in each channel, set the control in the center.

11 VIDEO SWITCHING

In the OFF position, this switch turns off the internal video preamplifier for the purest possible sound quality.

12 CARTRIDGE selector

This switch sets up the gain and input impedance of your amplifier's internal circuitry to match the type of cartridge being used on your turntable. Be sure you connect your turntable to the appropriate PHONO input jacks on the

back of the HK 6800/6900 (MM for moving magnet cartridges, or MC for moving coil cartridges). Then use this switch to select the type of cartridge mounted on your turntable. Note that you can connect both moving coil and moving magnet cartridge inputs and use this switch to select between them. The MC setting engages a special MC step-up amplifier stage.

13 VOLUME control

This knob controls the sound level. Turn the VOLUME control all the way down before you turn on your amplifier or change sound source. This will protect your speakers from being damaged by sudden high-volume sound.

14 FUNCTION selector

The FUNCTION selector controls which program source you are listening to.

- PHONO - Selects a turntable connected to either the MM or MC phono jacks.
- CD - Selects a compact disc player connected to the CD jacks.
- TUNER - Selects an AM or FM broadcast from a tuner connected to the tuner jacks.
- AUX - Selects sound from any component connected to the AUX jacks.
- A/V - Selects sound from an audio/video component such as a camcorder, VCR or TV tuner connected to the A/V jacks. Simultaneously the A/V video signal is switched to the MONITOR OUT jacks. To listen to a tape deck, use the VCR/TAPE MONITOR selector (16), described below.

15 RECORD OUT selector

This selector controls which program source you can record on the VCR(s) or tape deck(s) connected to your unit. Whatever source you select is sent to all tape decks connected to your HK6800 or HK6900, so you can record on both decks simultaneously.

- TUNER - In this position, the tuner signal is the source you are recording regardless of the position of the FUNCTION selector. This permits you to record the tuner signal while listening to a completely different source (selected on the FUNCTION selector, described above).
- SOURCE - When SOURCE is selected, whatever source you have selected on the FUNCTION selector will be the source you are recording.
- OFF - Leave the selector in this position when you are not recording. This will ensure the purest sound quality

when you listen directly to a source selected with the FUNCTION selector.

- COPY 1 TO 2 - In this position, you are recording *from* the deck or VCR connected to the VCR/TAPE 1 jacks *to* the deck or VCR connected to the VCR/TAPE 2 jacks.
- COPY 2 TO 1 - In this position, you are recording *to* the deck or VCR connected to the VCR/TAPE 1 jacks *from* the deck or VCR connected to the VCR/TAPE 2 jacks. For example, if you want to make a tape recording of a CD, set the RECORD OUT selector to SOURCE, and set the FUNCTION selector to CD.

16 VCR/TAPE MONITOR selector

The VCR/TAPE MONITOR selector enables you to listen to your VCR or tape deck. If a VCR is connected to the tape monitor you select, the corresponding video signal will be switched to the MONITOR OUT jacks. Note that this selector does not select the source for recording. It selects only the deck or VCR you are listening to. An important use for this selector is for monitoring during recording. To monitor during recording, select the deck that is recording. For listening to one VCR or tape deck while the other deck is recording a different source, select the deck that is not recording.

- 1 - In this position, you are listening to the deck or VCR connected to the VCR/TAPE 1 jacks.
- SOURCE - The SOURCE position turns off the output from your deck or VCR and returns you to the source you have selected on the FUNCTION selector.
- 2 - In this position, you are listening to the deck or VCR connected to the VCR/TAPE 2 jacks.

17 SPEAKER selector

You can connect either one or two sets of speakers to your HK6800 or HK6900. This selector enables you to play a single set of speakers by themselves, both sets of speakers at the same time, or to turn both sets of speakers off for headphone-only listening.

- OFF - Select this position to turn off both sets of speakers.
- 1 - Select this position to play the speakers connected to the SPEAKER SYSTEM 1 terminals.
- 2 - Select this position to play the speakers connected to the SPEAKER SYSTEM 2 terminals.
- 1 + 2 - Select this position to play both sets of speakers at the same time.

HK6800 and HK6900 Connections

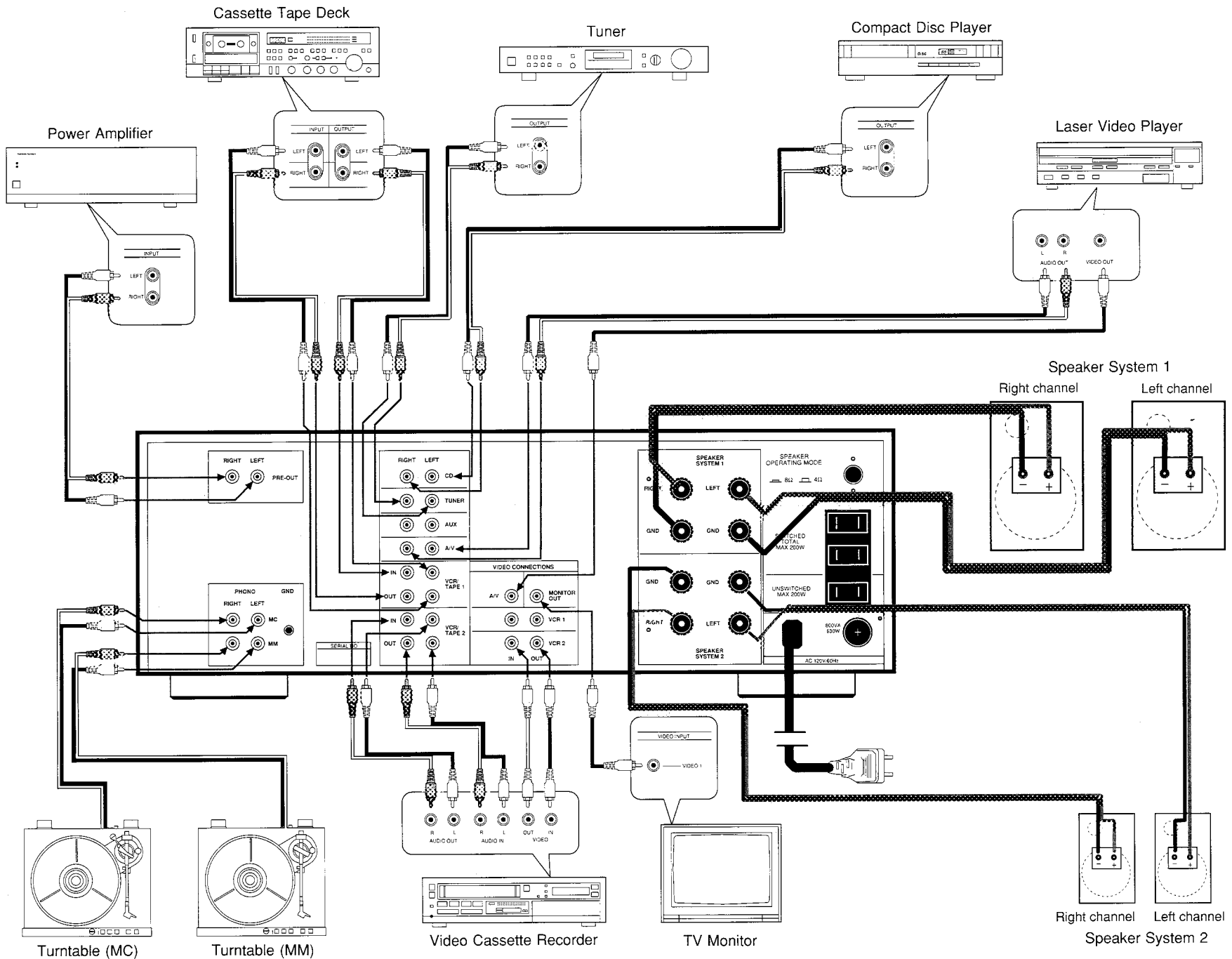

HK6800 and HK6900 Connections

Before you begin to connect this unit to your system, be sure that all components are turned off and unplugged from the electrical outlet.

As you connect each component, carefully connect the plugs to the input jacks, being sure to push the plugs in all the way. Loose connection of a plug can cause hum or other intermittent noise. Take care to match left and right component plugs with the left and right input jacks on the back of the amplifier. Common practice is to use the red plug as right, and the white, gray, or black plug as left.

Do not wind the component cables with the power cord; doing so may degrade the sound quality.

Power outlets

To the right of the back panel on North American and Japanese versions are located three AC power outlets. The two outlets labeled SWITCHED are controlled by the power switch on the front of the amplifier. When the power is switched off at the front panel button, power is also turned off to the SWITCHED outlets. You can plug the power cord of a tuner, tape deck, turntable, or other low-power component into these outlets. When you turn off your amplifier, units plugged into the SWITCHED outlets will be turned off simultaneously.

The SWITCHED outlets have a *combined* power rating of 200 watts. Make sure that the units that you plug into these outlets do not draw more than 200 watts total. Check the owner's manuals to determine how much power each unit draws.

The UNSWITCHED outlet is not controlled by the power switch. This outlet receives power as long as the HK6800 or HK6900 is plugged into an AC outlet. A unit plugged into the UNSWITCHED outlet can remain turned on even if your amplifier is turned off. This outlet has a power rating of 200 watts. Make sure that the unit you plug into this outlet does not draw more than 200 watts.

Connecting speakers

Speaker wires: For the best sound quality, you may choose to use the highest quality speaker cables you can afford. However, common "zip cord" from a hardware store can be used with excellent results if you use the correct gauge (thickness). The gauge of wire you need depends on the distance the wire must run from your amplifier to your speakers:

Wire length

Up to 8 feet
Up to 12 feet
Up to 20 feet
Almost any distance

Gauge of speaker wire

18 gauge
16 gauge
14 gauge
Special speaker cable

Make sure that the wires for both speakers are the same length, even if the distance from each speaker to the amplifier is different. Avoid coiling any excess speaker wire near the cables from your components, since it may degrade sound quality or cause hum or other noise in the system.

Speaker connection: First, examine your speaker wire to determine which lead to use for the positive terminal. One of the two leads will be marked in some way, such as being copper-colored, including a strand of yarn with one conductor, or having a ridge or a + symbol marked on the insulating material. Use the marked lead for the positive (red) terminal both on the speaker and on the back of the amplifier.

1. Remove about 3/4-inch of insulation from the end of each speaker wire. This bare section of wire will make the electrical connection with the terminals.

2. Twist each lead so that no loose strands stick out.

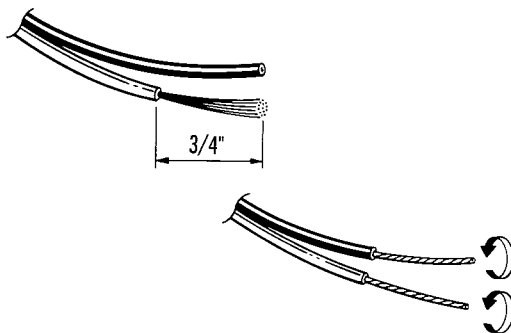

3. Insert about 1/2-inch of the wire that you have identified as positive into the red (+) connector on your right-channel speaker. Insert the other end of this positive lead into the RIGHT (red) Speaker 1 terminal on the back of your amplifier. Tighten the terminal knob, and the wire will be held securely.

4. Insert the other lead of the same wire into the black (-) connector on the same speaker. Insert the other end of this lead into the GND (black) Speaker 1 terminal on the back of the amplifier. The GND terminal is located directly below the RIGHT terminal.

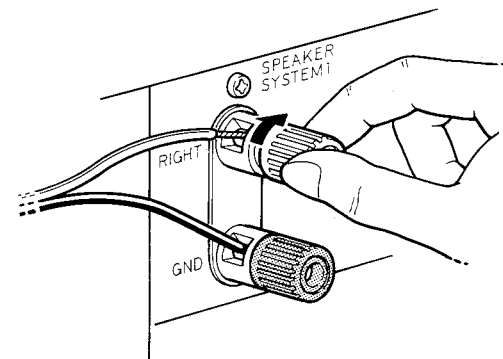

5. Repeat the above procedure for the left speaker.

6. Recheck the polarity of both sets of speaker wires, making sure that you have connected "red to red" and "black to black." If you accidentally connect red to black, your speakers will be out of phase. While this will not harm your system, your speakers will be incapable of producing normal bass response until the connection is corrected.

Setting the SPEAKER OPERATING MODE

switch: This switch, located in the top right corner of the back panel, optimizes the amplifier for the best possible operation with your speakers. *It is extremely important* that you set this switch before playing your speakers.

First, determine the impedance of your speakers. The impedance may be noted on the back of the speaker or in the owner's manual. If not, call the dealer or manufacturer to find out the impedance.

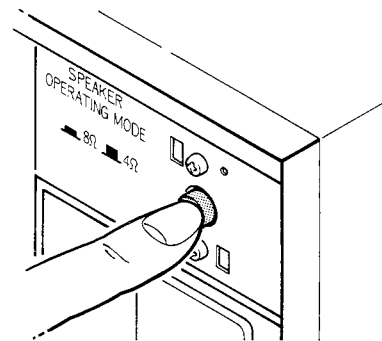

HK6800 and HK6900 Connections

If you are using a single set of 8-ohm speakers, set the SPEAKER OPERATING MODE switch to the 8 Ω position. In all other cases, use the 4 Ω position.

If you are in doubt about the impedance of your speakers, use the 4-ohm position, since the power amplifier runs cooler in this mode. Having this switch set to 8 Ω if you are using 4-ohm or 6-ohm speakers may result in overheating of the amplifier or failure of an internal fuse.

If you are using two pairs of speakers, it is important to note that the *combined total impedance* of both sets of speakers must not be less than 4 ohms. If the combined impedance is lower, you may overload the amplifier, resulting in overheating or failure of an internal fuse.

Two sets of 8-ohm speakers presents a combined total impedance of 4 ohms, which is an acceptable load for your amplifier as long as you set the SPEAKER OPERATING MODE switch to 4 ohms. If you have questions, consult your Harman Kardon dealer before adding a second set of speakers to your system.

Connecting a turntable

Your HK6800 or HK6900 has two sets of PHONO input jacks for connecting turntables. One set of jacks is marked MC, for Moving Coil. If you have a moving coil cartridge that generates at least 120 μ V mounted on your turntable, be sure you connect the turntable to the MC jacks. These jacks are internally wired to a special step-up amplifier stage.

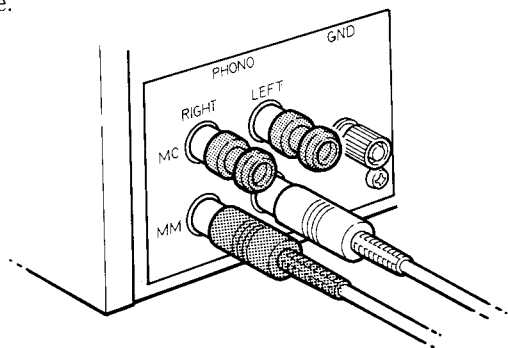

The other set of jacks is marked MM, for Moving Magnet. If you have a regular moving magnet cartridge mounted on your turntable, connect the turntable only to the MM inputs, as the sizeable volume boost of the MC jacks will cause volume problems and severe distortion.

Make sure you connect the thin ground wire from your turntable to the GND post located next to the phono input

jacks. Failure to connect this ground wire can result in a distracting hum when you play your turntable.

When only one turntable is used, be sure to insert the attached shorting pin plug into the PHONO MM or MC jacks that are not being used.

Connecting a CD player

Attach the patch cord from the CD input jacks to your compact disc player.

Connecting a tuner

Attach the patch cord from the TUNER input jacks to your tuner. Be sure you connect an antenna to your tuner; otherwise, the quality of your AM and FM signal may be poor.

Connecting a tape deck

You can have several tape decks connected to your HK6800 or HK6900. The best choice is to connect your tape deck(s) to the jacks labeled VCR/TAPE 1 or VCR/TAPE 2.

The IN and OUT connectors on your tape deck correspond to the opposite connectors on the back of your amplifier. That is, you connect OUT on the tape deck to IN on the amplifier.

A third tape deck can be connected to the AUX or A/V audio connectors if the deck will be used only for playback. Connect a patch cord from the audio OUT connectors on the tape deck to either the AUX or the A/V audio in connectors on your HK6800 or HK6900.

Note that the VCR/TAPE input jacks can be used for connecting either a tape deck or a VCR or other video source. Video equipment connection is described in the following sections.

Connecting a VCR

There are two ways you can connect a VCR to your system. One way is to use the A/V connectors; the other is to use the VCR/TAPE 1 and 2 connectors.

A/V: If you connect your VCR to the A/V inputs, you will be able to playback videocassettes, but not record on them. Connect a patch cord from the audio out connectors on your VCR to the A/V *audio* connectors. Then connect a patch cord from the video out connector on your VCR to the A/V *video* connector.

VCR/TAPE 1 and VCR/TAPE 2: If you connect your VCR to the VCR/TAPE 1 or 2 inputs, you will be able to both playback and record videocassettes. Connect a patch cord from the *audio* OUT connectors on your VCR to

the VCR/TAPE 1 (or 2) *audio* IN connectors. Connect *audio* IN on your VCR to the VCR/TAPE 1 (or 2) *audio* OUT connectors. Then connect a patch cord from the *video* OUT connector on your VCR to the VCR 1 (or 2) *video* IN connector. Connect *video* IN on your VCR to the VCR 1 (or 2) *video* OUT connector. Be sure you plug the video connector into the jacks that correspond with the audio connectors (e.g., if you've plugged the audio into VCR/TAPE 2, plug the video into VCR 2).

You can watch the picture from a VCR on your television while listening to the sound through your hi-fi system. If your source is high-quality (such as Hi-Fi VCR output), and you can position your television set between your speakers, the enhanced sound field will contribute greatly to your video enjoyment.

Connecting a video laser disc player

Connect a patch cord from the *audio* out connectors on your video disc player to the A/V *audio* connectors. Then connect a patch cord from the *video* out connector on your video laser disc player to the A/V *video* connector.

Connecting a video monitor

Connect a patch cord from the MONITOR OUT *video* connector to the *video* IN connector on your TV monitor/receiver. The video signal that goes to your monitor will come from the A/V component you have selected using the FUNCTION selector, or from the VCR selected using the VCR/TAPE MONITOR selector.

Connecting other video equipment

You can also use the A/V audio connectors to connect the audio (stereo or mono) output of a television tuner or MTS adaptor into your hi-fi system.

Connecting an external power amplifier

If you want to use your HK6800 or HK6900 simply as a preamplifier and connect it to an external power amplifier, use the PRE-OUT connectors in the upper-left corner. Connect the patch cord from the PRE-OUT jacks on the HK6800 or HK6900 to the jacks on your external power amplifier. Then connect your speakers to your external power amplifier.

Operation

Turn on the power to all components that aren't connected to the SWITCHED outlets on the back of your amplifier. Make sure the volume control on your HK6800 or HK6900 is turned all the way down, then turn the unit on. This procedure will protect your speakers from turn-on thumps (transients) from the other components.

Listening to a record

1. Set the FUNCTION selector to PHONO.
2. Set the CARTRIDGE selector to MM if the turntable you want to use has a moving magnet cartridge, or to MC if it has a moving coil cartridge.
3. Set the VCR/TAPE MONITOR selector to SOURCE.
4. Turn on the turntable and play the record.
5. If you notice that the record is warped, turn on the SUBSONIC filter to reduce turntable resonance.

If you hear a hum at average listening levels, turn all components off, then check to make sure that the PHONO and GND connections on the back of the amplifier are secure. Depending on the cartridge type used, less hum may be produced without the ground connection.

Listening to a CD, tuner or A/V component

1. Set the FUNCTION selector to the appropriate input (CD, TUNER, or A/V).
2. Set the VCR/TAPE MONITOR selector to SOURCE.
3. Turn on the component.

Playing a tape or videocassette

1. Set the VCR/TAPE MONITOR selector to 1 if the tape deck or VCR you want to play is connected to VCR/TAPE 1. Set the selector to 2 if the unit is connected to VCR/TAPE 2.

2. Turn on the tape or videocassette.

Make sure you return the VCR/TAPE MONITOR selector to SOURCE when you're finished playing the tape deck or VCR.

Recording on a tape deck or VCR

1. If you want to record from the tuner, set the RECORD OUT selector to TUNER. If you want to record from PHONO, CD, AUX, or A/V, set the RECORD OUT selector to SOURCE, then set the FUNCTION selector to PHONO, CD, AUX, or A/V.

2. Start the tape deck or VCR recording.

3. To monitor as you record, set the VCR/TAPE MONITOR selector to 1 if the tape deck or VCR you are recording on is connected to VCR/TAPE 1. Set the selector to 2 if the unit is connected to VCR/TAPE 2.

4. If you are recording from your tuner, you can listen to another program source without affecting your recording. Simply set the FUNCTION selector to whatever source you want to listen to. This selection will not affect your recording from the tuner.

If you have two decks or VCRs connected, you can record on both of them simultaneously, since the same signal is routed to both. You can also record on one deck and listen to the other by using the VCR/TAPE MONITOR selector.

Copying (dubbing) from one tape deck or VCR to another

1. Use the RECORD OUT selector to set the direction of the copying. For example, if you want to play a tape on the deck connected to VCR/TAPE 1 and record that tape on the deck connected to VCR/TAPE 2, select COPY 1 TO 2.

2. Start the first tape playing and the second tape recording.

3. To monitor as you record, set the VCR/TAPE MONITOR selector to 1 if the tape deck or VCR you're recording on is connected to VCR/TAPE 1. Set the selector to 2 if the unit is connected to VCR/TAPE 2. Make sure you return the VCR/TAPE MONITOR selector to SOURCE when you're finished listening to the tape deck or VCR.

4. To listen to another program source while you copy from one deck to another, return the VCR/TAPE MONITOR selector to SOURCE, then set the FUNCTION selector to whatever source you want to listen to. These selections will not affect your recording.

Playing a laser video disc

1. Set the FUNCTION selector to A/V.
2. Set the VCR/TAPE MONITOR selector to SOURCE.
3. Turn on the video disc player.

Copyright Information

Recording of copyrighted material for other than personal use is illegal without permission of the copyright holder.

Troubleshooting

If your HK6800 or HK6900 does not operate as expected, first check the items in the following list. If you cannot determine the source of the problem, contact your dealer or authorized Harman Kardon service representative.

No lights on the front panel.

1. Power cord is not plugged into power outlet.
2. Wall outlet or extension cord is faulty. Check for poor connections and/or blown fuse.
3. Breaker on plug strip has tripped. Reset breaker.

The PROTECT light goes on and stays on

1. The unit is overheated. Make sure that the unit is receiving adequate ventilation. Also check to make sure that the SPEAKER OPERATING MODE switch is set to 4Ω if you are using 4-ohm speakers (using the 8Ω setting with 4-ohm speakers can cause overheating). Be sure you give the unit adequate time to cool off; the PROTECT light will remain on until the unit is cool enough to operate safely, which may take 60 to 90 minutes. Your amplifier will cool off more quickly if you turn off its power switch.
2. Speaker wires are touching one another, causing a short circuit that activates protection circuits that shut down the amplifier. Check the speaker wires.
3. If you have ensured that the unit is not overheated and even with the speaker wires completely disconnected, the PROTECT light still remains on, take the unit to an authorized Harman Kardon service center for service.

No sound.

1. Speakers are connected to wrong set of speaker terminals.
2. SPEAKER selector is not switched to correct set of speakers.
3. Speaker wires are touching one another, causing a short circuit that activates protection circuits that shut down the amplifier.
4. FUNCTION selector has not been switched to the source currently playing.
5. VCR/TAPE MONITOR selector is switched to 1 or 2 while the source currently playing is CD, PHONO, TUNER, AUX or A/V. Switch VCR/TAPE MONITOR selector to SOURCE.

No sound from tape deck or VCR

1. VCR/TAPE MONITOR selector has not been switched to the correct unit.
2. Tape deck or VCR is plugged into the wrong set of input jacks.
3. Output of tape deck is plugged into OUT on back of amplifier. Plug OUT on tape deck into IN on amplifier.

Turntable sound is extremely faint

1. Turntable has been connected to wrong set of input jacks. If turntable has a moving magnet cartridge, connect

cables to the PHONO MM jacks; if turntable has a moving coil cartridge, connect cables to PHONO MC jacks.

Low-pitched hum or buzz from turntable

1. Ground wire from turntable has not been connected securely to ground terminal on amplifier.
2. Cable from turntable is too close to power cords or speaker wires.
3. Tiny wires connecting cartridge to turntable arm are not firmly connected.

Low frequency oscillation or "howling" when playing turntable

1. Too much bass boost is being applied. Turn off LOUDNESS and/or reduce amount of BASS tone control boost. Turn on the SUBSONIC filter.
2. Turntable is too close to speakers.
3. Turntable is placed on unstable surface.

Speakers lack bass

1. Polarity of one speaker has been reversed. Check speaker wires and ensure that the + terminal on the amplifier is connected to the + terminal on the speaker.

Sound quality of tuner is poor

1. Tuner's antenna is not connected or is not positioned properly.

Tone control is not functioning

1. The TONE DEFEAT switch is on, bypassing the tone controls.
2. The MAIN DIRECT switch is on, bypassing the tone controls.

Specifications**HK6900****HK6800**

Continuous Average Power (FTC) per Channel 20Hz – 20kHz,
Both Channels Driven

8 ohms:	170 Watts @ < 0.08% THD	120 Watts @ <0.08% THD
4 ohms:	170 Watts @ < 0.08% THD	120 Watts @ <0.08% THD

HCC (High instantaneous Current Capability):	±90 Amps	±70 Amps
--	----------	----------

Negative Feedback (overall):	12dB	12dB
------------------------------	------	------

Power Bandwidth, at half rated output, 8 ohms:	<10Hz – 100kHz	<10Hz – 100kHz
--	----------------	----------------

Frequency Response at 1 Watt output, +0/-3dB:	0.2Hz – 180kHz	0.2Hz – 180kHz
---	----------------	----------------

Slew Rate:	280 Volts/μsec	280 Volts/μsec
------------	----------------	----------------

Square Wave Rise Time:	1.8μsec	1.8μsec
------------------------	---------	---------

Transient Intermodulation Distortion (TIM):	Unmeasurable	Unmeasurable
---	--------------	--------------

Damping Factor:	70	70
-----------------	----	----

Signal-to-Noise Ratio (ref rated power output, A-Wtd)

Phono (MM):	83dB	83dB
Phono (MC):	76dB	76dB
Video/CD:	98dB	98dB

Input Sensitivity/Impedance

Phono (MM):	2.5mV/47k Ohms, 125 pF	2.5mV/47k Ohms, 125 pF
Phono (MC):	120μV/56 Ohms	120μV/56 Ohms
Video/CD:	250mV/22k Ohms	250mV/22k Ohms

Phono Overload (MM/MC):	150mV/7mV	150mV/7mV
-------------------------	-----------	-----------

RIAA Equalization 20Hz – 20kHz:	±0.2dB	±0.2dB
---------------------------------	--------	--------

Tone Control Range, Bass (50Hz)/Treble (10kHz):	±10dB/±10dB	±10dB/±10dB
---	-------------	-------------

Phase Shift (400Hz – 20kHz):	<5°	<5°
------------------------------	-----	-----

Subsonic Filter:	15Hz, 6dB/octave	15Hz, 6dB/octave
------------------	------------------	------------------

Phase-Correct Loudness Contour at 50Hz:	+6dB	+6dB
---	------	------

Weight (lbs/kgs):	37.5lbs/17.0kg	34.2lbs/15.5kg
-------------------	----------------	----------------

Dimensions (Width x Height x Depth):	17-3/8" x 6-5/16" x 15-15/16" 443 x 160 x 405 mm	17-3/8" x 6-5/16" x 15-15/16" 443 x 160 x 405 mm
--------------------------------------	---	---

Power Supply:	AC 120V, 60Hz	AC 120V, 60Hz
---------------	---------------	---------------

Power Consumption:	630W, 800VA	450W, 540VA
--------------------	-------------	-------------

All specifications and features subject to change without notice.