



MODEL  
THP525LS / THP650LS

**ELAN**<sup>TM</sup>  
HOME SYSTEMS

Life Just Got Better<sup>TM</sup>



# Contents

<b>Introduction</b> .....	<b>2-4</b>
Specifications .....	2
Features .....	4
<b>Installation</b> .....	<b>5-10</b>
Wiring .....	5
Mounting .....	7
Pointing Speakers .....	8
Setting Switches .....	10
<b>Applications</b> .....	<b>11-24</b>
Stereo .....	11
Home Theater .....	13
<b>Limited Lifetime Warranty</b> .....	<b>Back Page</b>



**WARNING: Do Not Exceed Speaker's  
Rated Power! Damage to Speaker  
and/or Amplifier Could Occur.**

# Introduction

Congratulations and thank you for purchasing ELAN TheaterPoint speakers. The TheaterPoint speaker line has been designed specifically to match the needs of dedicated Home Theater and critical listening areas within the home. Using state-of-the-art materials like woven Kevlar fiber cones, neodymium magnets, and aluminum phase plugs each speaker seamlessly reproduces movie soundtracks and music with the clarity and precision demanded in today's multi-channel environments. Advanced features such as three-way EQ switches, bass limiting circuits, custom Q crossovers, and pivoting tweeters allow flexibility and customization for virtually any circumstance where accurate audio reproduction is paramount.

TheaterPoint speakers have been designed as a family. Each speaker complements the others. All use similar components to create a coherent audio experience no matter what the content. TheaterPoint speakers are also designed to provide custom solutions for virtually any multi-room environment. In-wall, in-ceiling, on-wall, and free-standing speakers combine to create the exact setup that each home requires. No matter which combination is appropriate, TheaterPoint speakers provide sonic accuracy and reproduce all audio sources to ELAN's exacting standards.

## Specifications

### THP525LS

**System Type** ..... 2 Way Acoustic Suspension, Dual Woofer  
w/ Pivoting Tweeter

#### Woofer

Cone ..... 2 X 5.25" Woven Kevlar w/Aluminum Phase Plug  
Magnet ..... Shielded Ceramic  
Surround ..... Butyl Rubber  
Basket ..... Cast Aluminum

#### Tweeter

Diaphragm .....1" (25mm) Pivoting Woven Kevlar Dome  
Magnet ..... Shielded Neodymium

**Crossover** ..... 3rd Order Custom Q @ 2.4kHz

**Switches** ..... EQ (Bright/Neutral/Warm) & Bass Limiting

**Nominal Impedance** ..... 6 Ohms

**Sensitivity** ..... 88dB

**Frequency Response** ..... 58Hz to 20kHz

**Power Handling** ..... 80 Watts RMS

#### Dimensions

W/H/D ..... 6 7/8" x 19 1/2" x 8 1/2"  
(175mm x 495mm x 216mm)

Weight ..... 24 lbs. (10.87kg)

**Specifications (cont'd.)****THP650LS**

**System Type** ..... 2 Way Acoustic Suspension, Dual Woofer  
w/ Pivoting Tweeter

**Woofer**

Cone ..... 2 X 6.5" Woven Kevlar w/Aluminum Phase Plug  
Magnet ..... Shielded Double Ceramic  
Surround ..... Inverted Butyl Rubber  
Basket ..... Cast Aluminum

**Tweeter**

Diaphragm ..... 1" (25mm) Pivoting Woven Kevlar Dome  
Magnet ..... Shielded Neodymium

**Crossover** ..... 3rd Order Custom Q @ 2.2kHz

**Switches** ..... EQ (Live/Neutral/Dead) & Bass Limiting

**Nominal Impedance** ..... 6 Ohms

**Sensitivity** ..... 90dB

**Frequency Response** ..... 50Hz to 20kHz

**Power Handling** ..... 110 Watts RMS

**Dimensions**

W/H/D ..... 7 3/4" x 19 1/2" x 12 1/2"  
(197mm x 495mm x 318mm)

Weight ..... 28 lbs. (12.7kg)

## Features

- **Long Throw Woven Kevlar Cone Woofers**
- **Kevlar Fiber Dome Pivoting Tweeters w/ Neo Magnet & Fluid Cooling**
- **Woofers Aluminum Phase Plugs**
- **Cast Aluminum Basket**
- **Custom Q High Order Crossovers**
- **Inverted Butyl Rubber Surrounds**
- **EQ Switch**
- **Bass Limiting Switch**
- **OmniMount Compatible**
- **'TheaterPoint' Pointing Laser Included**
- **Gloss Black Finish**

# Installation

The Installation process is divided into two distinct processes:

## Wiring Mounting

After carefully considering the intended application (defining a Listening Area, Home Theater/Stereo, etc.) specific mounting locations can be decided upon. Once the specific locations are determined, installation can commence.

## Wiring

Before actually running any wire or cable, take the time to look around each room or area of the house and plan your wire paths for maximum efficiency. Look for routes through uncluttered parts of the stud wall or ceiling that allow you to group all low-voltage wires wherever possible. It is a good practice to label both ends of all cables and to protect wires by tying a plastic bag over the ends.

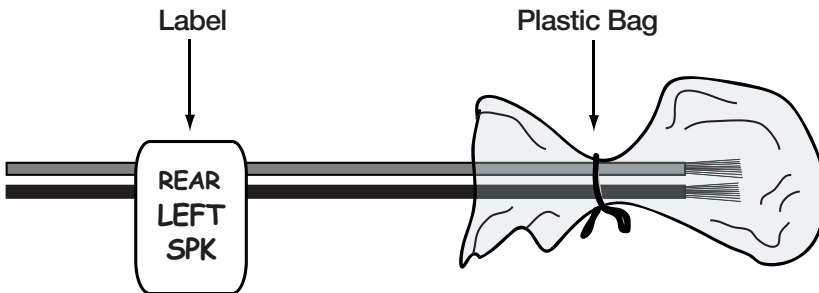

**Note 1:** Low voltage wiring must be run in accordance with the National Electrical Code as well as any other applicable provisions of the local building codes in your area. In some cases (such as commercial installations), running the wire in conduit may be required. If you have any questions concerning the wiring of speakers in your home, contact your local building and inspection department.

**Note 2:** It is recommended that you use quality CL-2 or CL-3 rated stranded speaker wire when installing ELAN TheaterPoint speakers. Solid-core "Romex" type wire is not acceptable! Use at least 16AWG speaker wire for runs up to 100 feet, and at least 14 AWG speaker wire for runs up to 200 feet. If you must cross high-voltage lines, always do so at a 90 degree angle to avoid audible hum through the speakers!

**Wiring** (cont'd.)

When pre-wiring for a Home Theater, run 14-16AWG stranded speaker wire from the equipment location (head-end) to each speaker location. Use speaker wall plates in the listening room as termination points and use ELAN PSP6 or PSP12 Precision Panels for neat and accurate speaker wire management at the head-end equipment location.

**Note:** When pre-wiring for a Home Theater, it is essential to make direct wire runs from the head-end to each speaker. Do not run speaker wires in series or parallel, and do not “daisy-chain” speakers to common wiring.

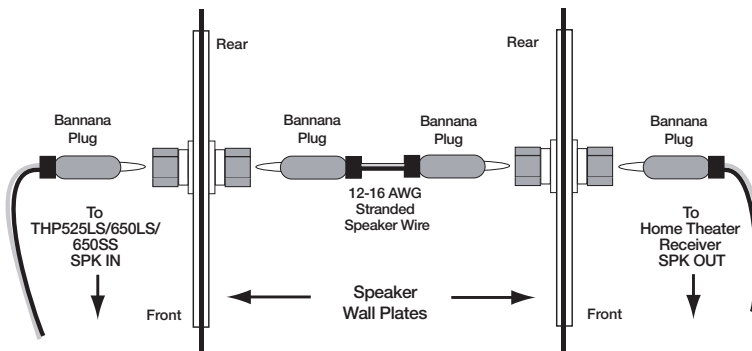

There are instances where TheaterPoint speakers will be connected directly to an amplifier. Use a high quality speaker cable of equal length for each Left and Right speaker directly from the amplifier to each speaker. The use of spade lugs or bannana plugs is recommended.



## Mounting

There are typically two situations that can exist when mounting cabinet Home Theater speakers:

### Wall Mount Shelf or Speaker Stand

#### Wall Mount

Speakers should be placed slightly above ear level when situated in the listening area, or pointed slightly downward when mounted higher.

**Note:** *ELAN THP525LS and THP650LS TheaterPoint speakers are compatible with **OmniMount 30.0 Series** speaker mounts. Please see the instructions included with the speaker mounts for specific information.*

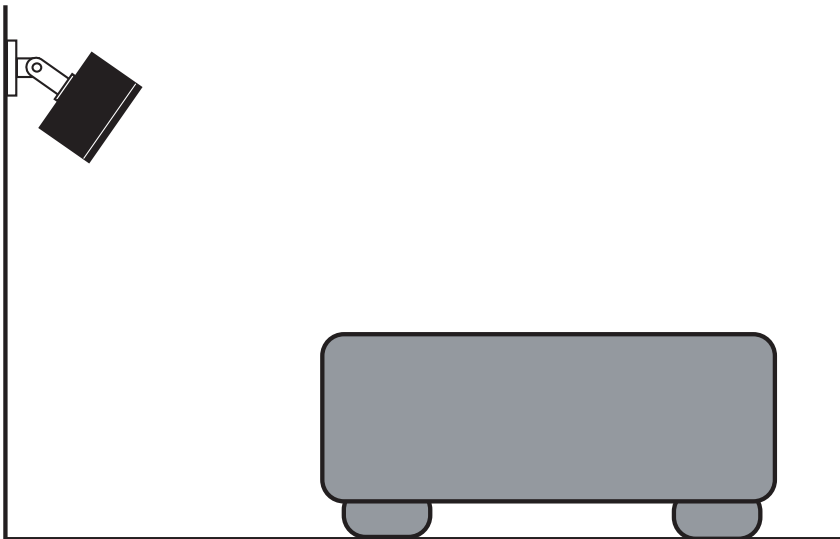

#### Shelf or Speaker Stand

Make sure that speaker wires are free from obstructions or sharp bends. When placing speakers on stands or in open areas, ensure that the speaker wires do not cause a tripping hazard.

## Pointing Speakers

TheaterPoint speakers are specifically designed to produce outstanding audio quality when properly placed in relationship to the listening area. Human hearing relies on mid-range and high frequencies to determine spatial direction (where a sound is coming from). Mid-range and high frequency drivers (tweeters) tend to produce narrow soundfields that sound much better when pointing directly at the listener whereas low frequency drivers (woofers) envelop much larger areas and tend to be more omnidirectional. The tweeter can be fine-tuned using ELAN's exclusive TheaterPointer Laser Pointing Device for pinpoint sonic accuracy in Home Theaters and critical listening applications.

### Pointing the Tweeter

All TheaterPoint speakers include ELAN's exclusive TheaterPointer Laser Pointing Device for precise tweeter adjustment. Because the human ear relies heavily on high frequencies to locate sound, and because high frequency drivers create a narrow soundfield, it is important to align tweeters precisely. Stereo imaging and surround sound effects and dialogue are greatly improved by pointing the tweeter correctly.

#### To Correctly Point the Tweeter:

1. Move the tweeter so that it points toward the desired listening position.
2. Turn TheaterPointer on by pressing the power button.
3. Place the TheaterPointer into the triangular hole located on the tweeter's protective cover. Notice the red beam of light emanating from the TheaterPointer.

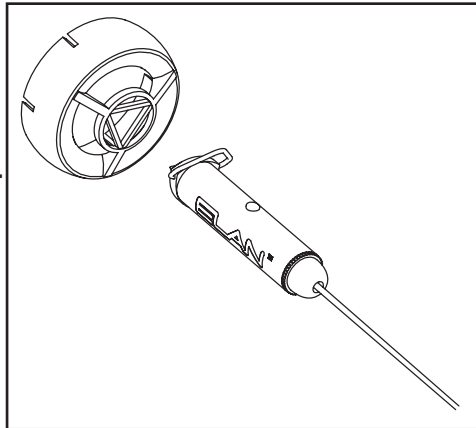

**Pointing the Tweeter (cont'd.)**

4. Position the tweeter such that the red spot of light is pointing directly at the center of the listening area (as shown below).
5. Repeat this process for each TheaterPoint speaker in the system with the exception of **THP650D** and **THP650SS**.

If Utilizing THP650D In-Wall Dipole or THP650SS Dipole speakers as side rear channels of a 5.1, 6.1, or 7.1 surround sound system, the tweeters should NOT point directly at the listening position. Instead, they should point obliquely to the listening area as shown below.

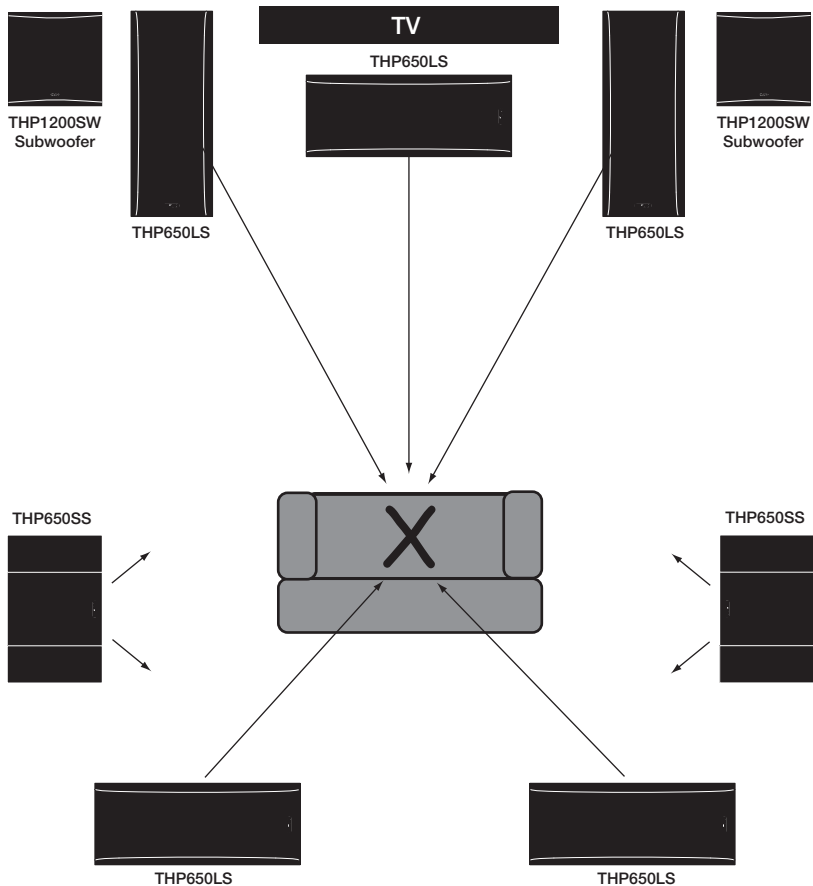

## Setting Switches

Once the speakers are wired, mounted, and positioned correctly, use the EQ switches to fine-tune the speakers based on local environmental variables such as hardwood floors, thick draperies, etc. The two EQ switches are labelled “**EQ**” (Equalizer) and “**BASS**”. The **EQ** switch compensates for the “liveness” or “deadness” of the room while the **BASS** switch cuts bass by approximately - 20dB.

### EQ Switch

Select the **W** (Warm) position on the EQ switch to compensate for “live” rooms where sound bounces and reflects from hard surfaces like tile or hardwood floors, large glass surfaces/windows, stone or brick walls, etc. Select the **B** (Bright) position to compensate for “dead” rooms where sound is absorbed by soft materials like heavy drapes, thick carpeting, upholstered furniture, etc. Use the **N** (Neutral) position if no compensation is required.

### BASS Switch

Select the **+** position for normal bass operation if the speaker is used full-range without a subwoofer. Select the **0** position to reduce bass frequencies by approx. 20dB. The **0** option is designed to protect the the speaker during high volume operation and should only be used when a subwoofer is present in the system.

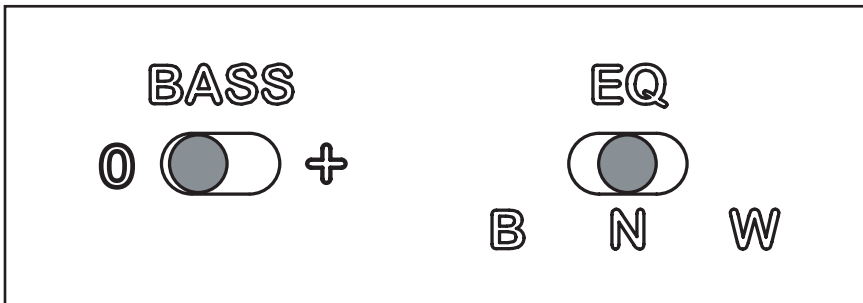

## Applications

All TheaterPoint speakers have similar “voices” designed to work together to create a seamless, high-quality Home Theater or critical listening experience. ELAN strongly recommends installing TheaterPoint speakers in matched groups (Left, Center, Right, Rear, Sub) in order to preserve the acoustic integrity of the source material. The following section describes each TheaterPoint speaker in appropriate applications with other TheaterPoint speakers.

### Stereo

Certain TheaterPoint speakers lend themselves very well to stereo critical listening applications. Please keep in mind that a defined stereo listening area must be present in order to achieve maximum benefit from stereo placement.

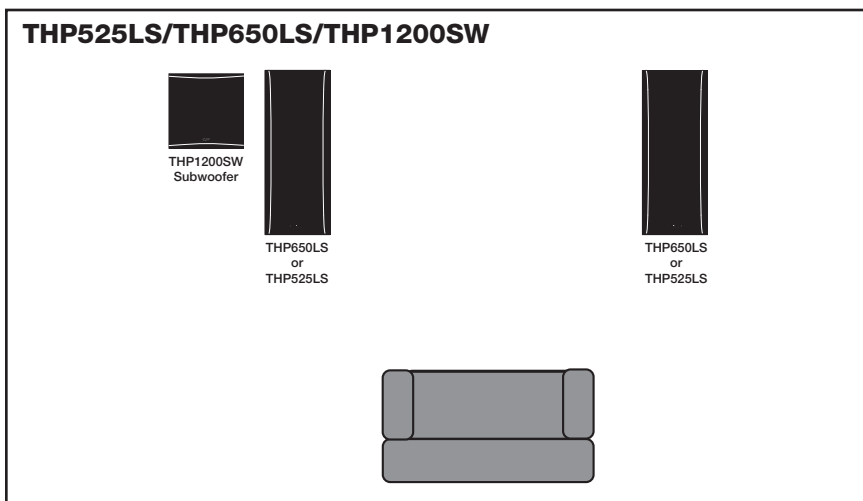
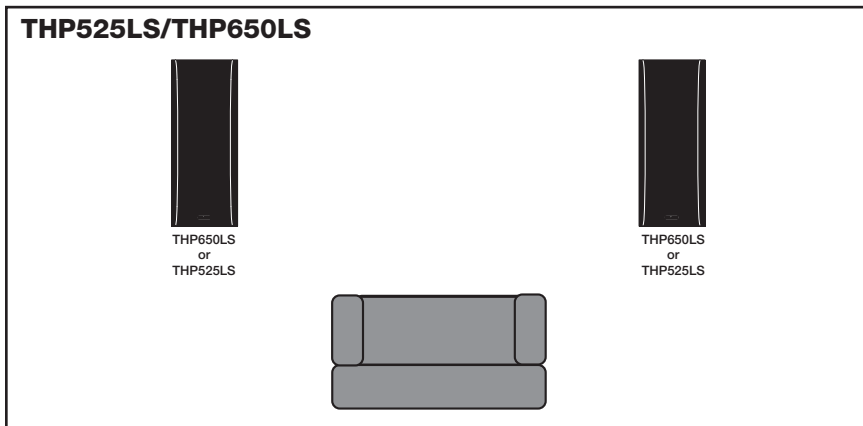

**Stereo Applications (cont'd.)**

**THP800C**

Critical listening areas require a well-defined listening position. Make sure to point the speakers toward the listening area as shown.

THP800C



THP800C

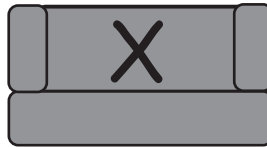

**THP800C/THP1200SW**

Add a THP1200SW subwoofer to increase bass response. This adds richness to the music and makes a huge improvement in sound quality.

THP800C



THP1200SW  
Subwoofer

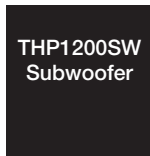

THP800C



## Home Theater

It is essential to use voice-matched speakers in any Home Theater application. Sound emanates from each speaker in turn, and all should sound the same. TheaterPoint speakers satisfy this requirement perfectly, and should be used in combinations shown in the following section.

### Center Channel Positioning

A center channel speaker should be placed as close as possible to the video display utilized in a Home Theater. In-wall center channel speakers should be mounted immediately above or below the screen as shown below. If using a cabinet speaker like ELAN's THP525LS or THP650LS as a center channel, position it on a stand immediately below the screen. A Center Channel speaker can also mount on a shelf above the screen - possibly in a cabinet or entertainment center.

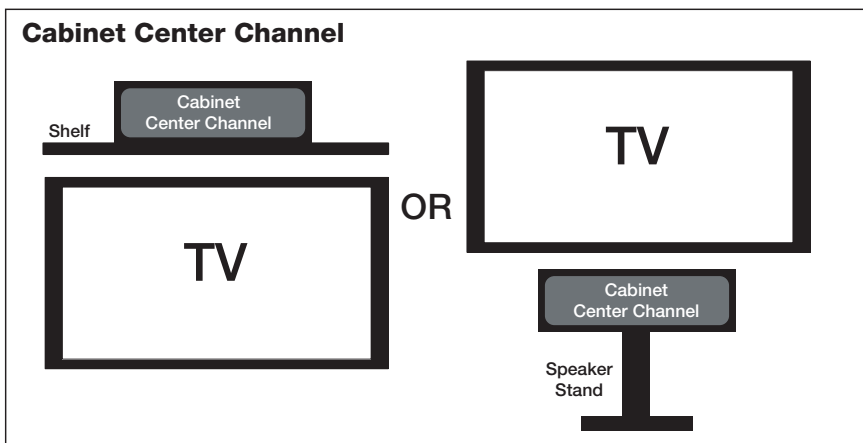
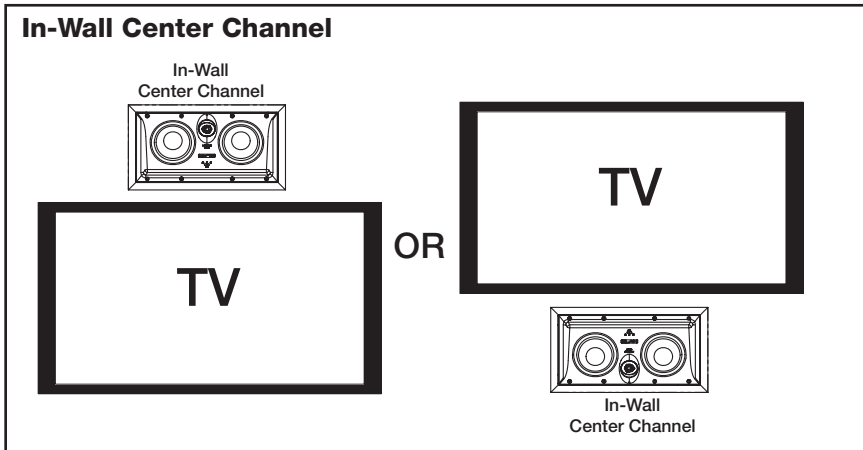

### Subwoofer Positioning

Subwoofers are considered to be omnidirectional. They produce low bass frequencies that are not especially localized. The human ear does not rely on these frequencies to place sounds in space therefore, placement is not as important as with other types of speakers. Place subwoofers along the front wall of the room approximately 2-3 feet from the corners. Expect a 3-9dB bass boost if the subwoofer is placed directly in the corner of a room (called “corner loading”). It is usually not advisable to place subwoofers directly next to the seating position in a Home Theater.

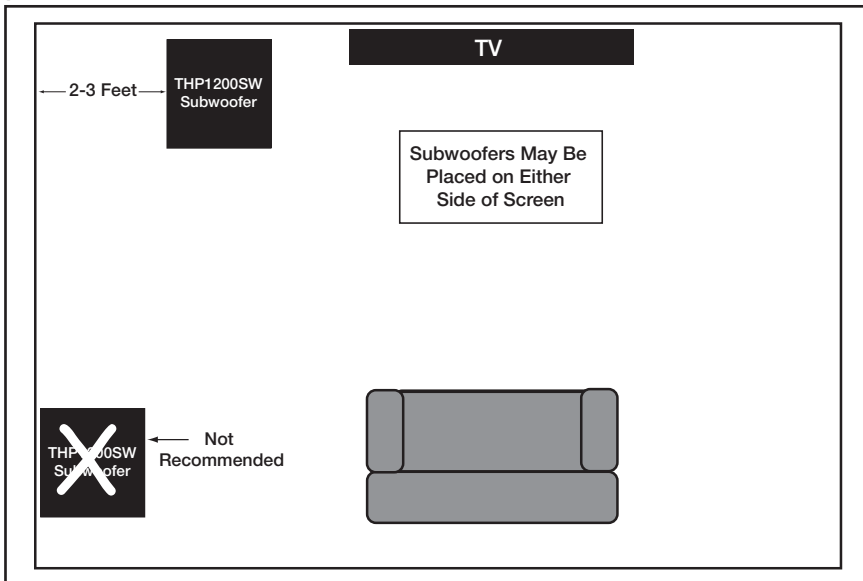

### Multiple Subwoofers

It is sometimes desirable to install multiple subwoofers for increased bass response in a Home Theater. Place the subwoofers equal distance from the screen in similar locations as shown below.

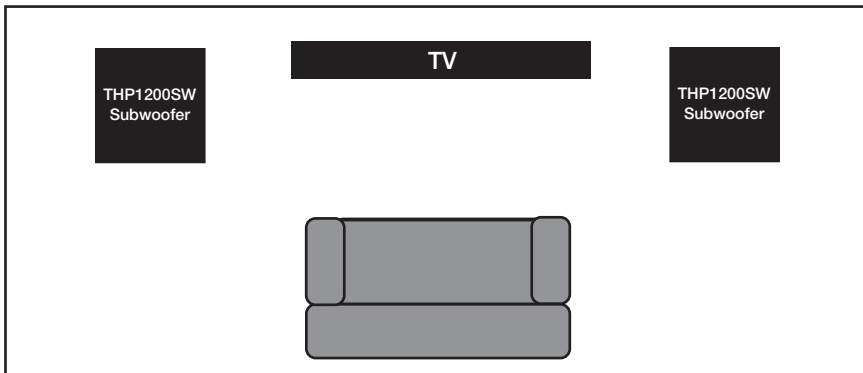



## 5.1 Surround Sound Applications

**THP525LS/THP650LS** - Free-Standing L/C/R  
**THP650SS** - On-Wall Dipole Rear Side  
**THP1200SW** - Subwoofer

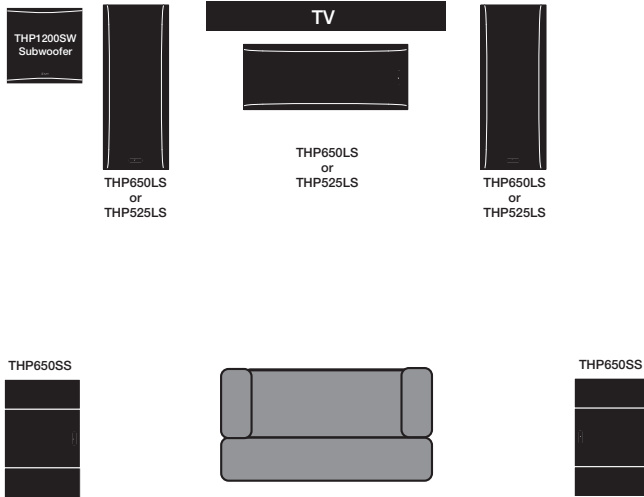

**THP800C** - In-Ceiling L/C/R & Rear  
**THP1200SW** - Subwoofer

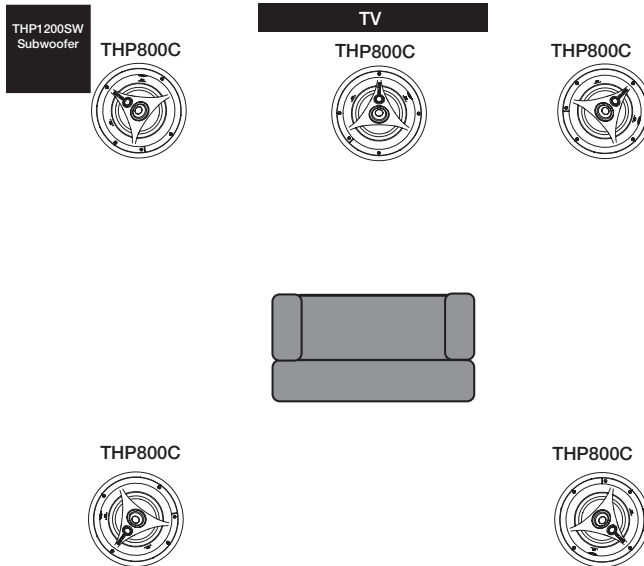

**5.1 Applications (cont'd.)**

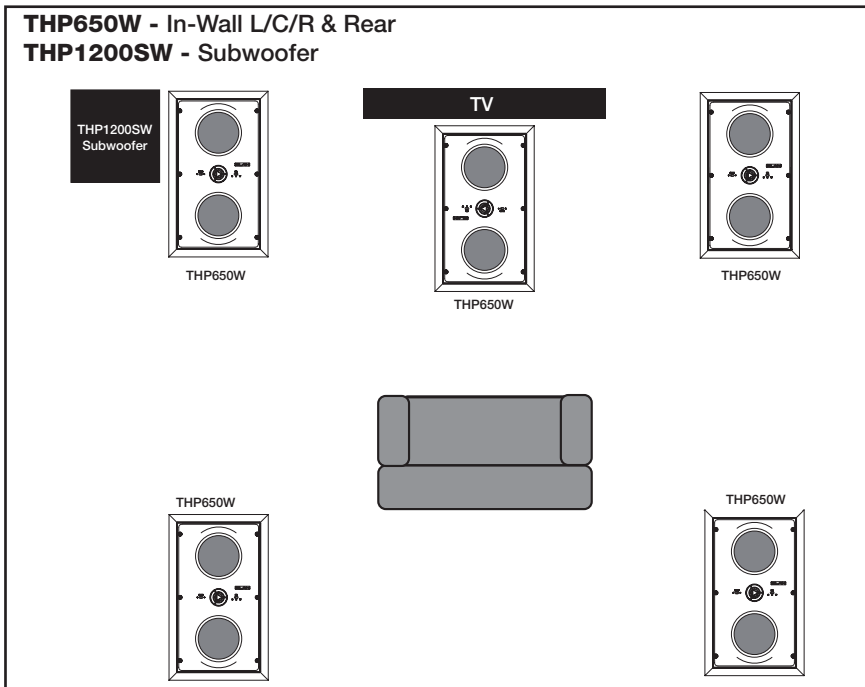
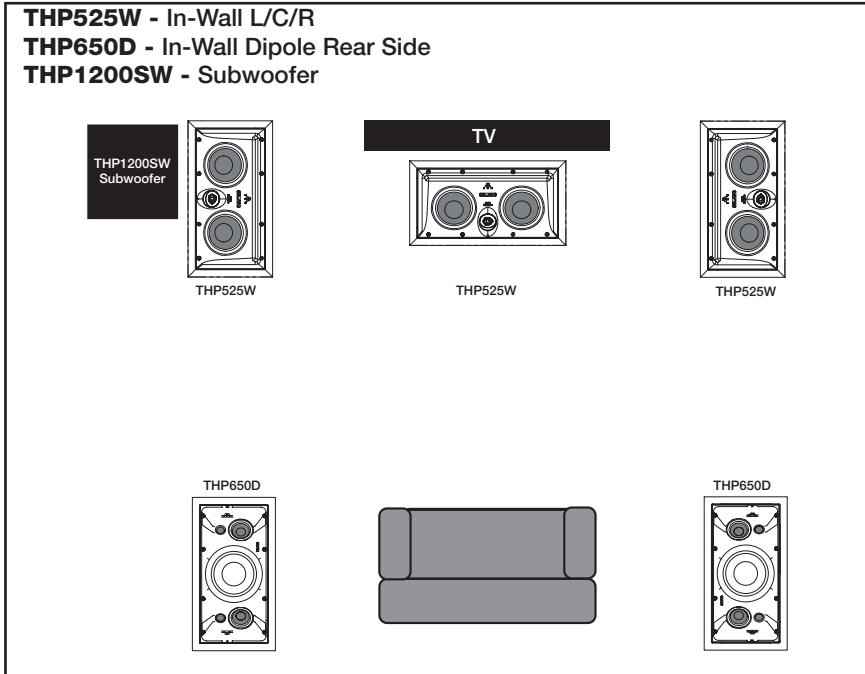

**5.1 Applications (cont'd.)**

- THP650W - In-Wall Left/Right**
- THP525W - In-Wall Center**
- THP650D - In-Wall Dipole Rear Side**
- THP1200SW - Subwoofer**

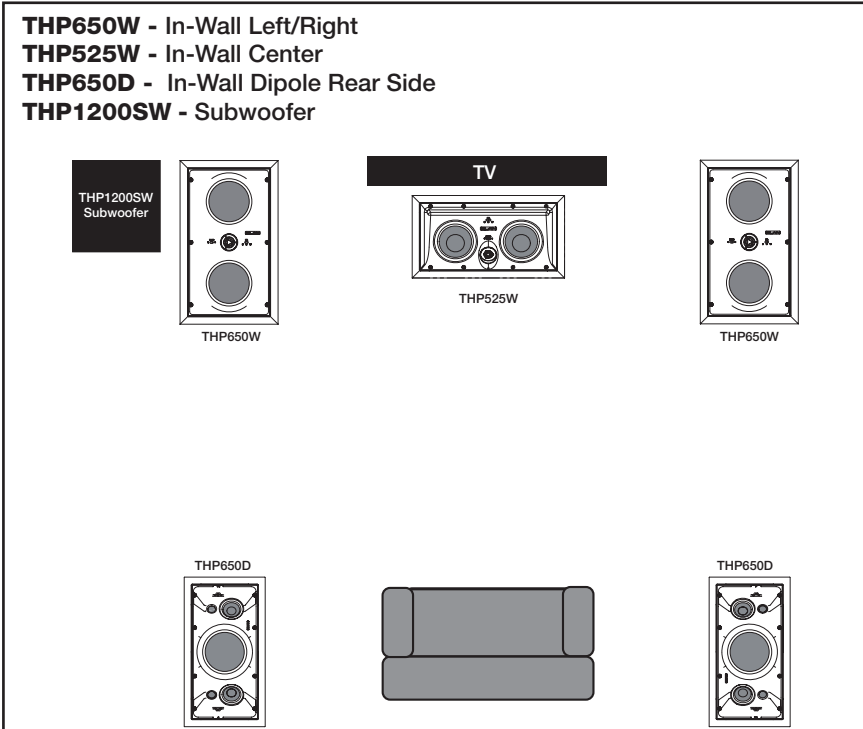

- THP525LS/THP650LS - Free-Standing L/C/R**
- THP650D - In-Wall Dipole Rear Side**
- THP1200SW - Subwoofer**

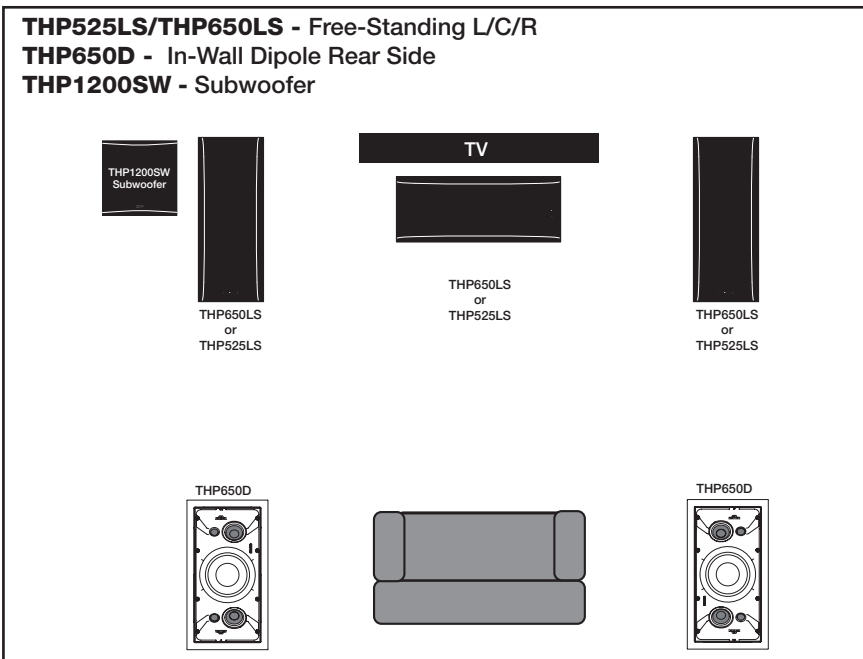

**5.1 Applications (cont'd.)**

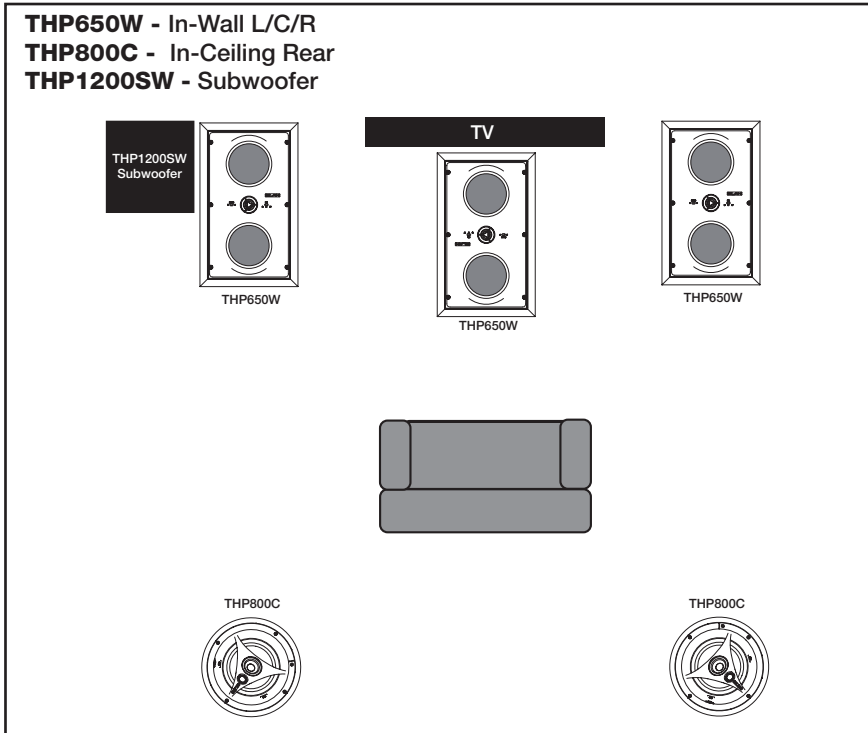
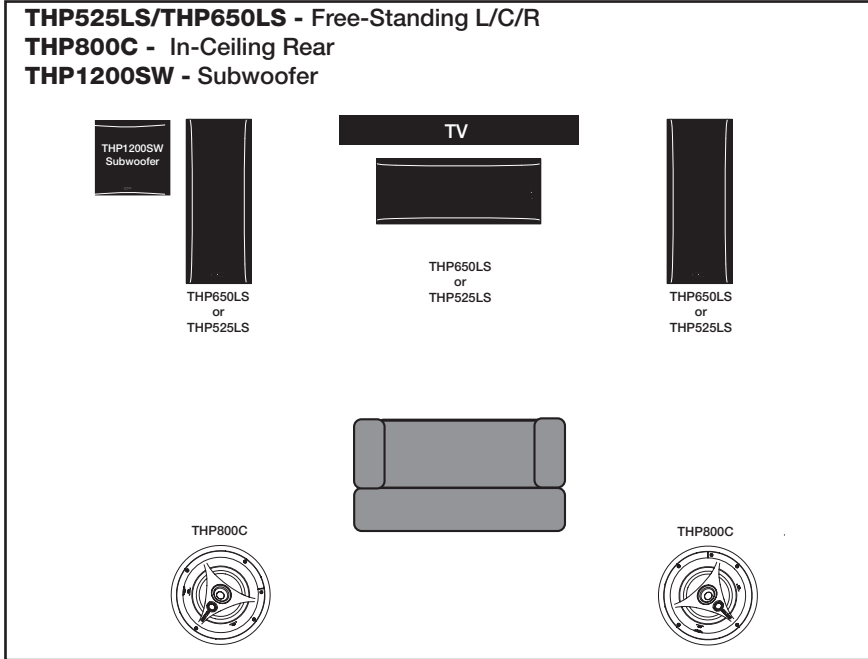

**5.1 Applications (cont'd.)**

**THP525W - In-Wall L/C/R**  
**THP800C - In-Ceiling Rear**  
**THP1200SW - Subwoofer**

THP1200SW  
Subwoofer

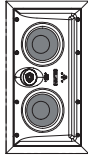

THP525W

TV

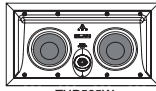

THP525W

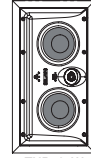

THP525W



THP800C



THP800C



**THP525W - In-Wall Center**  
**THP650W - In-Wall L/R**  
**THP800C - In-Ceiling Rear**  
**THP1200SW - Subwoofer**

THP1200SW  
Subwoofer

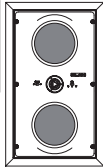

THP650W

TV

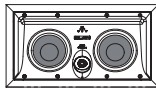

THP525W

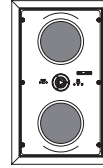

THP650W



THP800C



THP800C



## 6.1/7.1 Surround Sound

6.1 and 7.1 surround sound systems utilize additional rear and/or rear side speakers to enhance the audio effects contained in a soundtrack. Any of the previous examples can easily become a 6.1 or 7.1 system by changing the configuration of the rear channels. The diagrams in this section show **rear** and **side rear** speakers only!

### 6.1 Systems

Typical 6.1 systems use two rear side speakers with a center rear speaker. Several logical combinations can be created using Theater-Point speakers as shown in the following examples.

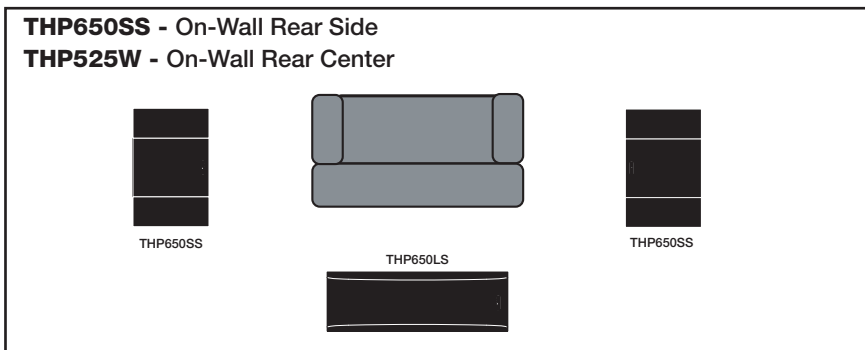
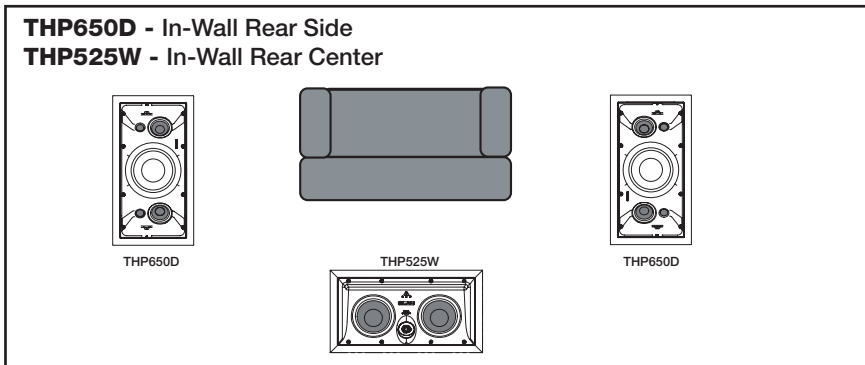
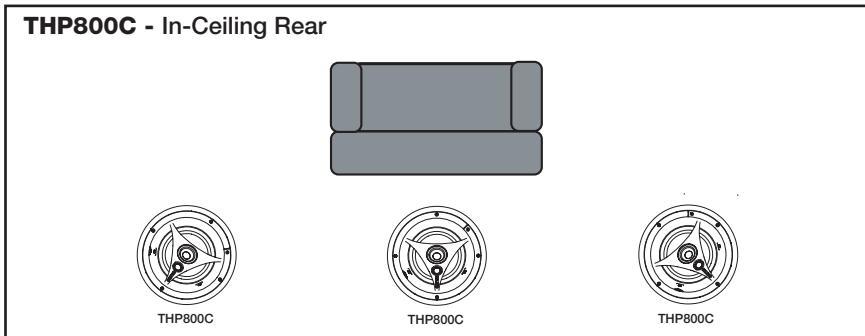

**6.1 Applications (cont'd.)**

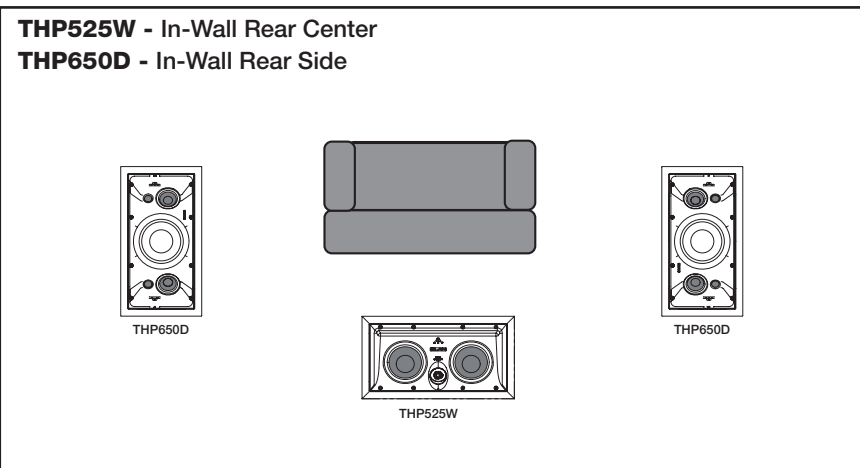
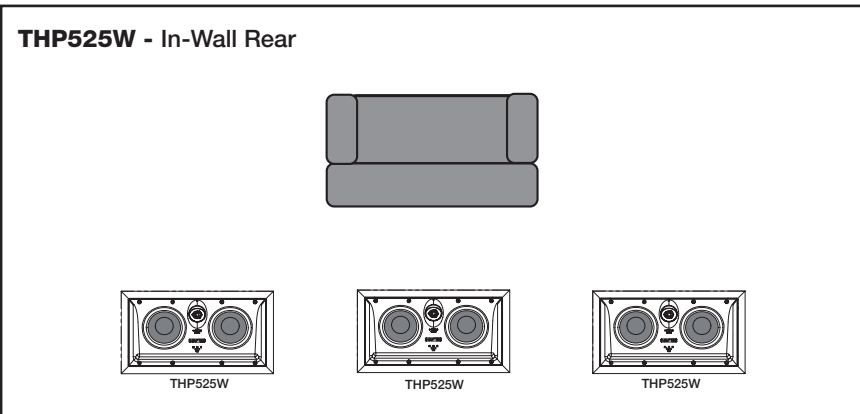
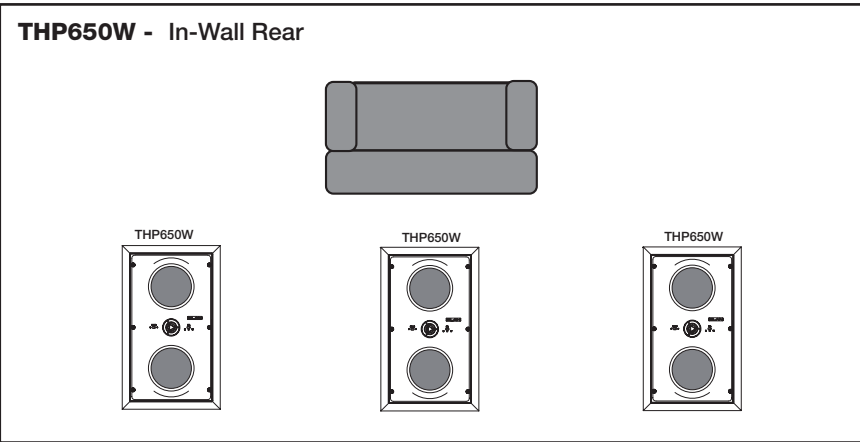

### 7.1 Systems

Use a total of four speakers for rear Surround effects when configuring 7.1 systems. Several logical combinations can be created using TheaterPoint speakers as shown in the following examples.

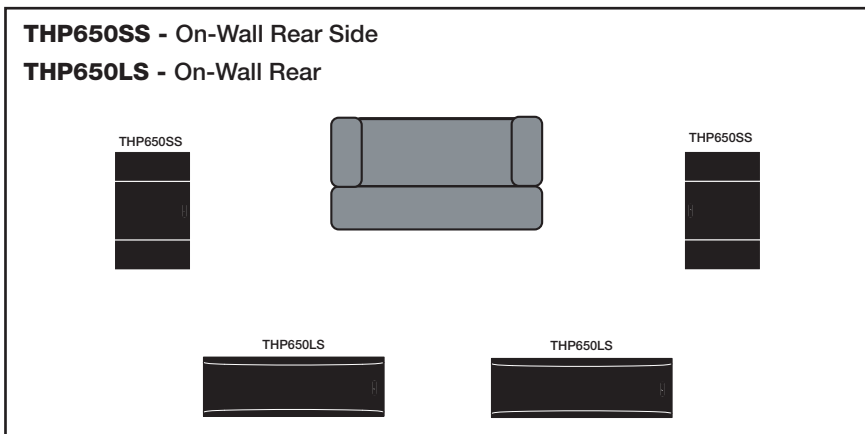
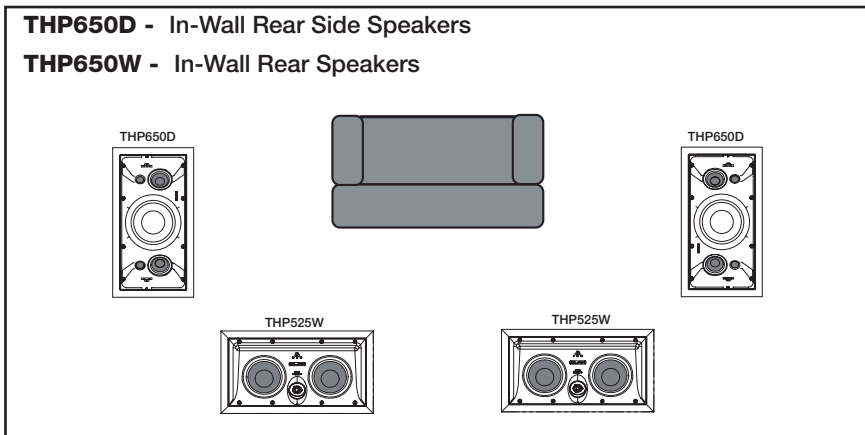
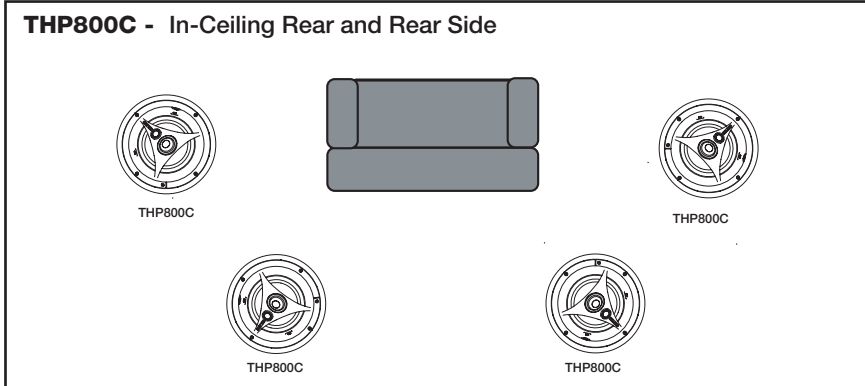



### 7.1 Applications (cont'd.)

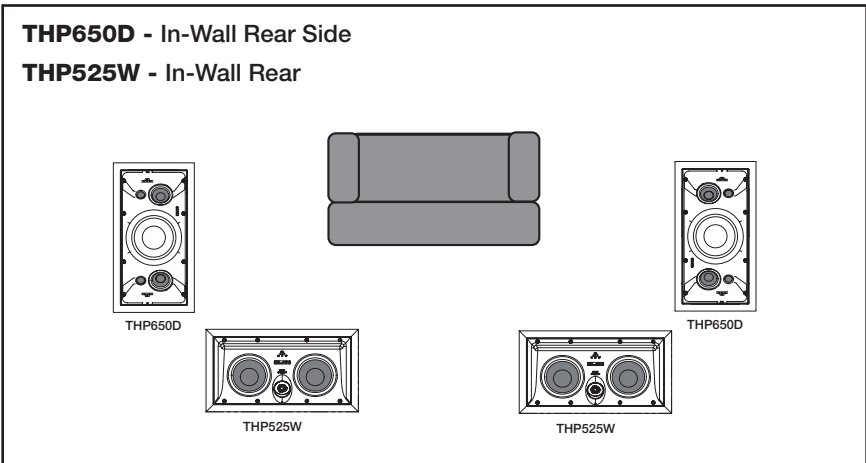
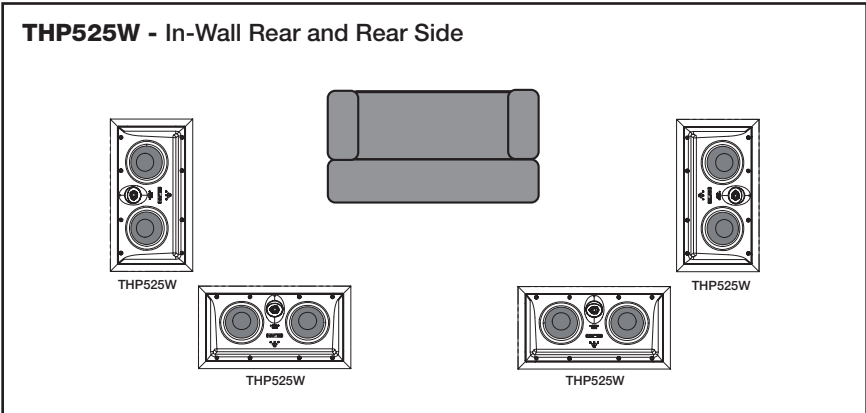
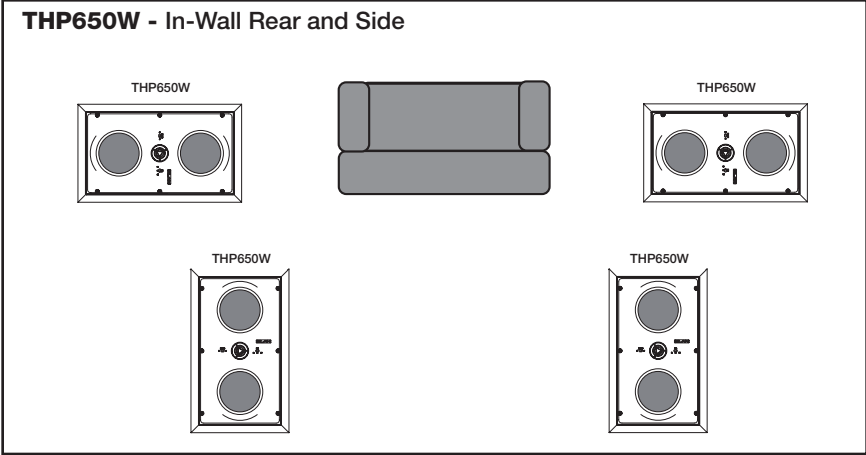

# High Performance 7.1 Surround System

**THP650LS** - Free-Standing L/C/R

**THP650SS** - On-Wall Rear Side

**THP525LS** - On-Wall Rear

**THP1200SW** - Subwoofers

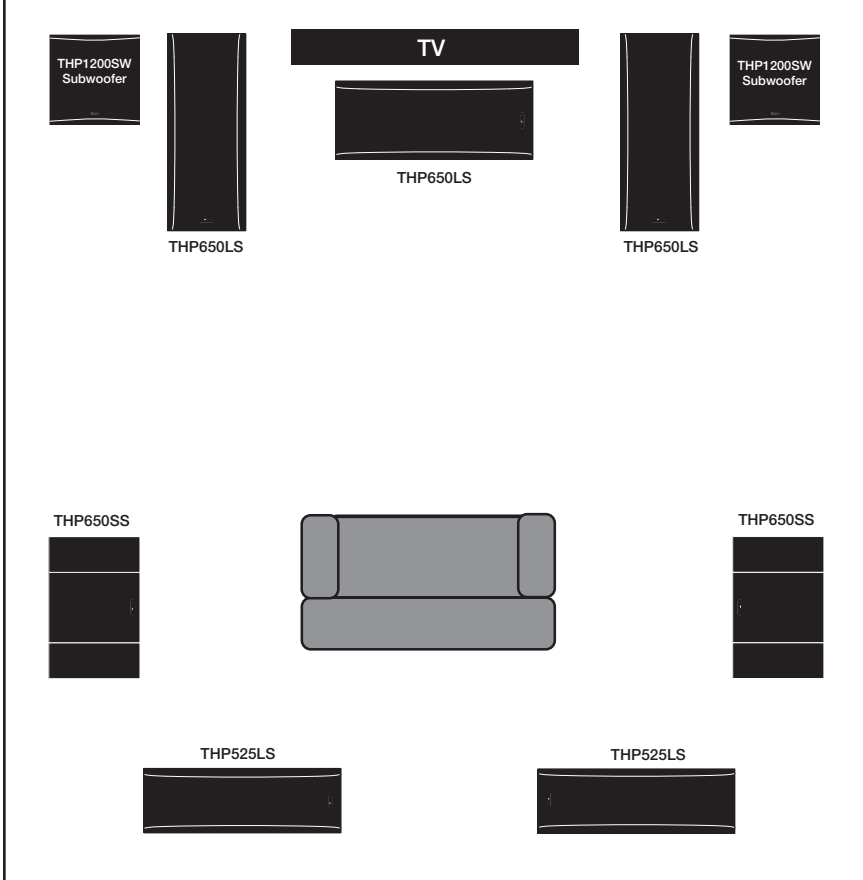



## **Limited Lifetime Warranty**

ELAN HOME SYSTEMS, L.L.C. ("ELAN") warrants to the original retail purchaser that THP525LS and THP650LS speakers and speaker brackets are free from defects in materials and workmanship, provided that the product was purchased from an authorized ELAN Home Systems Dealer.

If the above purchaser discovers such item was not as warranted above and promptly notifies ELAN writing, ELAN shall repair or replace the items at the company's option. This warranty shall not apply (a) to equipment not manufactured by ELAN, (b) to equipment which shall have been installed by other than an authorized ELAN installer, (c) to installed equipment which is not installed to ELAN's specifications, (d) to equipment which shall have been repaired or altered by others than ELAN, (e) to equipment which shall have been subjected to negligence, accident, or damage by circumstances beyond ELAN's control, including, but not limited to, lightning, flood, electrical surge, tornado, earthquake, or any other catastrophic events beyond ELAN's control, or to improper operation, maintenance or storage, or to other than normal use of service. With respect to equipment sold by, but not manufactured by ELAN, the warranty obligations of ELAN shall in all respects conform and be limited to the warranty actually extended to ELAN by its supplier. The foregoing warranties do not cover reimbursement for labor, transportation, removal, installation, or other expenses which may be incurred in connection with repair or replacement.

Except as may be expressly provided and authorized in writing by ELAN, ELAN shall not be subject to any other obligations or liabilities whatsoever with respect to equipment manufactured by ELAN or services rendered by ELAN.

THE FOREGOING WARRANTIES ARE EXCLUSIVE AND IN LIEU OF ALL OTHER EXPRESSED AND IMPLIED WARRANTIES EXCEPT WARRANTIES OF TITLE, INCLUDING BUT NOT LIMITED TO IMPLIED WARRANTIES OF MERCHANTABILITY AND FITNESS FOR A PARTICULAR PURPOSE.