



EDELBROCK CAT-BACK EXHAUST SYSTEM
for 1993-1994 Chevrolet/GMC Trucks, 2WD 350 V8
with Single Stock Exhaust Outlet

Catalog #5630, #5631, #5640, #5641, #5650, #5651, #5655, & #5656

INSTALLATION INSTRUCTIONS

Please study these instructions carefully before installing your new Cat-Back Exhaust System. If you have any questions or problems, please contact our **Technical Hotline at: 1-800-416-8628**, 7:00 am to 5:00 pm, Monday through Friday, Pacific Standard Time or e-mail us at edelbrock@edelbrock.com. Please fill out and mail your warranty card.

Suggested Tools for Installation:

- 3/8" ratchet set and 15mm, 7/16", and 9/16" sockets
- 7/16", 9/16" and 15mm wrenches
- Jackstands
- Liquid penetrant
- Oxy/Acetylene torch or equivalent (for removal of old system)

Application:

	<u>Side Exit</u>	<u>Rear Exit</u>
Pick-Up, short bed	#5630	. . . #5631
Pick-Up, long bed	#5640	. . . #5641
Pick-Up, short bed extended cab (141" W.B.) . . .	#5650	. . . #5651
Pick-Up, long bed extended cab (155" W.B.) . . .	#5655	. . . #5656

Disassembly

1. Raise vehicle and support with the proper jackstands, leaving the rear suspension hanging.
2. Use caution around hot exhaust systems to avoid burns.
3. Use penetrating oil on all nuts, bolts and rubber hangers.
4. Remove all nuts, bolts, and hangers from the rear of the catalytic converter to the tail pipes.
5. Remove the old exhaust system from the rear working forward towards the catalytic converter. Use an Oxy/Acetylene torch to heat the junctions of the old pipes to ease removal.

preference. Snug the hanger to the flanges, keeping in mind that when you have the pieces all hung, you may have to re-adjust height. Make sure that the muffler is level to the chassis and the hanger is perpendicular to the muffler case. We suggest that you start with the bottom hole.

Assembly

1. Place 3" U-clamps on the outlet end of the intermediate pipe, push the hanger into the stock rubber hanger in the truck, and bolt the pipe to the catalytic flange.
2. Slip muffler onto the intermediate pipe and support it.
3. Attach axle pipe to muffler using two gaskets and 3/8" nuts, bolts, and lock washers.
4. Place the muffler hanger supplied on the back side of the pipe flange, and use the 1-1/2" x 3/8" bolt to attach it to the middle hole through the flanges. Push it through the stock rubber hanger and put on the 1/2" locknut. The hanger has two holes to accommodate your height

5. Install the tailpipe assembly next, using the remaining 1-1/4" x 3/8" nuts, bolts, washers and gaskets. Bolt the rear hanger bracket to the flanges and insert it into the stock hanger. Adjust the clearance to the fender (side exit systems) or the rear bumper (rear exit systems) to a minimum of 7/8" and tighten all fasteners.
6. The small two-hole bracket is for the final adjustment of tail pipe-to-bumper (or fender) clearance, and may not be needed in some applications.
7. The factory-installed bumper may vary as much as 3/4" in height. You may want to adjust your bumper for optimum appearance, especially with the RPM Series chrome exhaust tips. To make room for chrome tip installation, we suggest a minimum of 7/8" clearance from the tailpipes to the bumper.
8. Check for clearance to body, frame, and driveline as you tighten the system from front to rear.
9. Check for leaks and correct, if necessary.

WARNING: Exhaust gas contains carbon monoxide, a deadly invisible gas. Correct any leaks before driving!

KIT CONTENTS

Qty.	Part #	Description	Qty.	Part #	Description
1	25-5507	RPM Series Muffler	1	23-1607	1.9" Extension bracket
1	25-3014	Intermediate Pipe (#5630 #& #5631)	1	23-1610	Rear muffler hanger bracket
1	25-3015	Intermediate Pipe (#5640 & #5641)	1	23-4007	Tailpipe hanger bracket
1	25-3016	Intermediate Pipe (#5650 & #5651)	2	-	1/2"-13 plated locknuts
1	25-3017	Intermediate Pipe (#5655 & #5656)	2	-	3/8"-16 x 1-1/2" plate bolts
1	25-3011	Axle Pipe Assembly	9	-	3/8"-16 x 1-1/4" plate bolts
1	25-3007	Side Outlet Tail Pipe Assembly or	11	-	3/8"-16 plated nuts
1	25-3008	Rear Outlet Tail Pipe Assembly	11	-	3/8" plated lockwashers
4	33-5400	2-1/2" two-bolt gaskets	1	-	3" U-clamp (#5655 & #5656
1	23-1606	Two-hole extension bracket			have two 3" U-clamps)

EDELbrock CAT-BACK EXHAUST SYSTEM
for 1993-1994 Chevrolet/GMC Trucks, 2WD 350 V8
with Single Stock Exhaust Outlet
Catalog #5630, #5631, #5640, #5641, #5650, #5651, #5655, & #5656

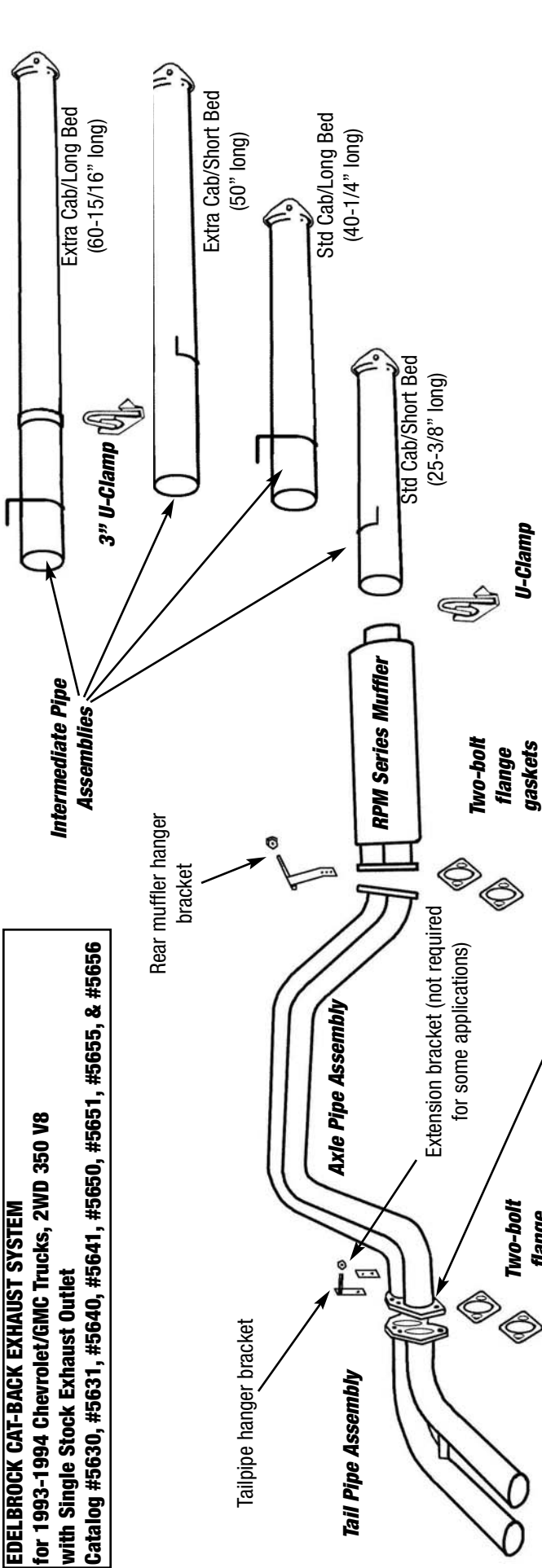

WARNING!!!

- Support your vehicle with proper jackstands or ramps rated for the total vehicle weight. Place stands so that the rear axle is allowed to hang free for easy removal.
- These cat-back systems are engineered to fit stock catalytic converters or equivalent replacements. If your original system has been modified, Edelbrock will not warranty fit or performance.

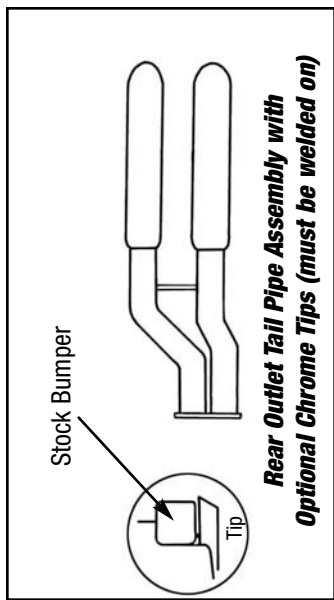
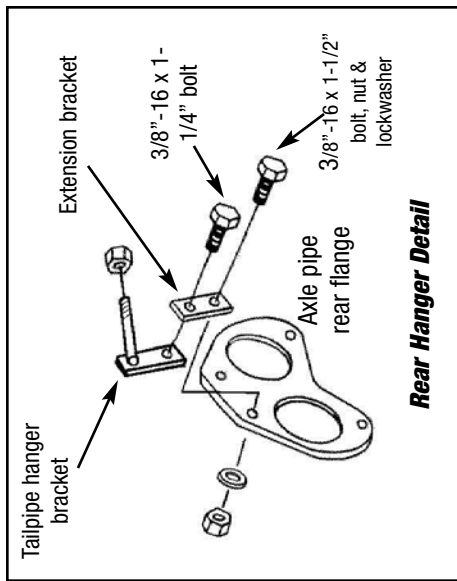

Edelbrock Corporation
2700 California Street
Torrance, CA 90503
Toll-Free Tech Line: 1-800-416-8628
Office: 310-781-2222
Tech E-Mail: edelbrock@edelbrock.com