

**Kramer Electronics, Ltd.**



# **USER MANUAL**

**Model:**

**VP-747**

*Universal Presentation Matrix Switcher / Scaler*

## Contents

|          |  |           |
|----------|--|-----------|
| <b>1</b> | <b>Introduction</b>  | <b>1</b>  |
| 1.1      | About the VP-747   | 1         |
| <b>2</b> | <b>Getting Started</b>   | <b>1</b>  |
| 2.1      | Quick Start  | 2         |
| <b>3</b> | <b>Overview</b>  | <b>3</b>  |
| 3.1      | About HDMI   | 5         |
| <b>4</b> | <b>Your VP-747 Universal Presentation Matrix Switcher / Scaler</b> | <b>6</b>  |
| <b>5</b> | <b>Installing on a Rack</b>  | <b>11</b> |
| <b>6</b> | <b>Connecting the VP-747</b>                                       | <b>12</b> |
| 6.1      | Connecting Different Source Types                                  | 14        |
| 6.2      | Connecting the Outputs   | 15        |
| <b>7</b> | <b>Connecting the VP-747 Control Ports</b>                         | <b>16</b> |
| 7.1      | Connecting a PC (via RS-232)                                       | 16        |
| 7.2      | Connecting the AUDIO CONTROL Port                                  | 17        |
| 7.3      | Connecting the VP-747 to the Kramer VP-727T                        | 18        |
| 7.4      | Connecting the VP-747 via the ETHERNET port                        | 19        |
| <b>8</b> | <b>Understanding the VP-747</b>                                    | <b>19</b> |
| 8.1      | Understanding the UNIVERSAL Inputs                                 | 19        |
| 8.2      | Understanding the PREVIEW/PROGRAM Outputs                          | 19        |
| 8.2.1    | The Transition from Preview to Program                             | 22        |
| 8.3      | Switching/Scaling of an Input                                      | 22        |
| 8.4      | Understanding the PIP Button Feature                               | 23        |
| 8.5      | Locking and Unlocking the Front Panel                              | 24        |
| <b>9</b> | <b>Operating the VP-747</b>  | <b>25</b> |
| 9.1      | Operating via the OSD MENU Screen                                  | 25        |
| 9.1.1    | Preview and Program Setting Commands                               | 25        |
| 9.1.1.1  | Preview and Program Input and Output Settings                      | 29        |
| 9.1.2    | The Transition Menu Items  | 31        |
| 9.1.3    | The Audio Menu Items   | 32        |
| 9.1.4    | The Utility Menu Items   | 33        |
| 9.1.4.1  | Save Lock  | 34        |
| 9.1.4.2  | Input Lock   | 34        |
| 9.1.4.3  | Save/Recall/Eraser Setting Commands                                | 34        |
| 9.1.5    | The Information Menu Items   | 34        |
| 9.2      | Operating via the Front Panel LCD Display                          | 35        |
| 9.3      | Operating via the Infrared Remote Control Transmitter              | 36        |
| 9.4      | Operating via the Ethernet   | 37        |
| 9.4.1    | Installing and Running the Configuration Software                  | 37        |
| 9.4.2    | Configuring the Ethernet Connection                                | 37        |
| 9.4.3    | Control the VP-747 via the Ethernet/Serial Port                    | 38        |

|           |                                      |           |
|-----------|--------------------------------------|-----------|
| <b>10</b> | <b>Technical Specifications</b>      | <b>39</b> |
| <b>11</b> | <b>VP-747 Communication Protocol</b> | <b>40</b> |

## Figures

|  |    |
|--|----|
| Figure 1: VP-747 Universal Presentation Matrix Switcher / Scaler Front Panel | 7  |
| Figure 2: VP-747 Universal Presentation Matrix Switcher / Scaler Rear Panel  | 9  |
| Figure 3: Connecting the VP-747  | 13 |
| Figure 4: Connecting the INPUTS (an example)                                 | 14 |
| Figure 5: Connecting the PREVIEW OUT / PROGRAM OUT Connectors                | 15 |
| Figure 6: Connecting the PC  | 16 |
| Figure 7: Connecting the VP-727A to the VP-747                               | 17 |
| Figure 8: Connecting the VP-747 to the VP-727T                               | 18 |
| Figure 9: Example showing the use of the PREVIEW and PROGRAM Output          | 21 |
| Figure 10: Menu Screen Icons   | 25 |
| Figure 11: Preview and Program Setting OSD Menus                             | 25 |
| Figure 12: Input Mode Setting Screen   | 29 |
| Figure 13: Output Mode Setting Screen  | 30 |
| Figure 14: Transition Screen   | 31 |
| Figure 15: Audio Screen  | 32 |
| Figure 16: Utility Screen  | 33 |
| Figure 17: Info Screen   | 34 |
| Figure 18: Example of how to use the LCD Display                             | 35 |
| Figure 19: Remote Transmitter  | 36 |
| Figure 20: VP-747 Control Application Screen                                 | 38 |

## Tables

|  |    |
|--|----|
| Table 1: Front Panel VP-747 Universal Presentation Matrix Switcher / Scaler Features | 8  |
| Table 2: Rear Panel VP-747 Universal Presentation Matrix Switcher / Scaler Features  | 10 |
| Table 3: Connecting the Different Source Types                                       | 14 |
| Table 4: PIP Source Appearance Availability  | 23 |
| Table 5: Preview and Program Setting OSD Menus                                       | 26 |
| Table 6: Input Mode Functions  | 29 |
| Table 7: Output Mode Functions   | 30 |
| Table 8: Transition Screen Functions   | 31 |
| Table 9: Audio Screen Functions  | 32 |
| Table 10: Utility Screen Functions   | 33 |
| Table 11: Remote Transmitter Functions   | 36 |
| Table 12: VP-747 Control Application Menu  | 38 |
| Table 13: Technical Specifications of the VP-747                                     | 39 |
| Table 14: Set Commands   | 41 |

## 1 Introduction

Welcome to Kramer Electronics! Since 1981, Kramer Electronics has been providing a world of unique, creative, and affordable solutions to the vast range of problems that confront the video, audio, presentation, and broadcasting professional on a daily basis. In recent years, we have redesigned and upgraded most of our line, making the best even better! Our 1,000-plus different models now appear in 11 groups<sup>1</sup> that are clearly defined by function.

### 1.1 About the VP-747

The **VP-747** *Universal Presentation Matrix Switcher / Scaler* is a true multi-standard video to graphics scaler and seamless switcher with eight universal inputs comprised of five BNC connectors each of which can accommodate a composite video, s-Video (Y/C), component video (RGB/YUV), RGBS, or RGBHV signal. Input 1 and input 2 also accommodate DVI / HDMI<sup>2</sup> inputs. It has dual scalers, one for the preview and the other for the program output. Dual scalers are required to do "live" seamless transitions from one source to another. It is ideal for these typical applications:

- Presentation applications that require a preview option
- Projection systems in conference rooms, board rooms, auditoriums, hotels, and churches
- Presentations requiring seamless switching between inputs, using special effects, cuts and fades

The package includes these items: **VP-747** *Universal Presentation Matrix Switcher / Scaler*, power cord<sup>3</sup>, infrared remote control transmitter (including the required battery), null-modem adapter, and this user manual<sup>4</sup>.

## 2 Getting Started

We recommend that you:

- Unpack the equipment carefully and save the original box and packaging materials for possible future shipment
- Review the contents of this user manual
- Use Kramer high performance high resolution cables<sup>5</sup>

---

1 GROUP 1: Distribution Amplifiers; GROUP 2: Switchers and Matrix Switchers; GROUP 3: Control Systems; GROUP 4: Format/Standards Converters; GROUP 5: Range Extenders and Repeaters; GROUP 6: Specialty AV Products; GROUP 7: Scan Converters and Scalers; GROUP 8: Cables and Connectors; GROUP 9: Room Connectivity; GROUP 10: Accessories and Rack Adapters; GROUP 11: Sierra Products

2 The HDMI connector connects to a DVD source via the Kramer ADC DM/HF adapter

3 We recommend that you use only the power cord that is supplied with the machine

4 Download up-to-date Kramer user manuals from the Internet at this URL: <http://www.kramerelectronics.com>

5 The complete list of Kramer cables is on our Web site at <http://www.kramerelectronics.com>

## 2.1 Quick Start

This quick start chart summarizes the basic steps when connecting a **VP-747**:

**Step 1: Mount the machine - see section 5**

Mount the machine in a rack or stick the 4 rubber feet to the underside

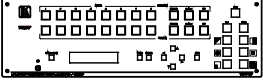

**Step 2: Connect the inputs/outputs - see section 6**

**Connect the Inputs:**

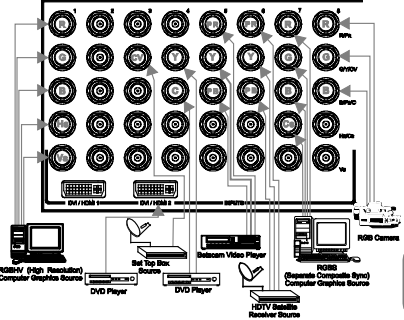

**Connect the Preview/Program outputs:**

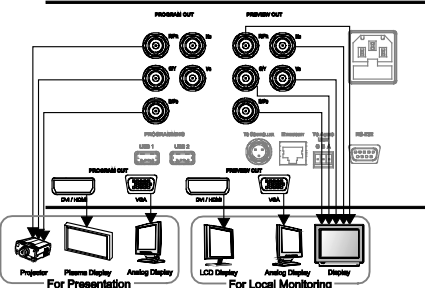

**Step 3: Connect the control ports - see section 7**

Connect to the control ports (optional): RS-232, RS-485, and/or the ETHERNET

**Step 4: Turn the power ON**

**Step 5: Operate the machine - see sections 8 and 9**

Select the Program and Preview inputs

Switch Preview to program (with transition effects)

Select the transition mode

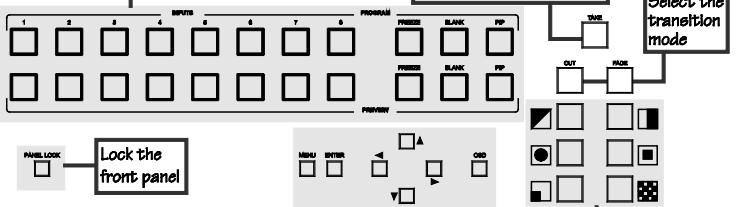

**Lock the front panel**

**Use the OSD Menu buttons**

**Select the transition effect**

**OPERATE VIA THE OSD**



Operate via the front panel menu-driven OSD, LCD, IR remote control, RS-232, ETHERNET, and/or control panel

### 3 Overview

The **VP-747** *Universal Presentation Matrix Switcher / Scaler* is a true multi-standard video to graphics scaler and presentation switcher for a wide variety of presentation and multimedia applications. It consists of a very high quality scaler with many user-selectable graphics or HDTV output resolutions, as well as a user definable output mode<sup>1</sup>.

The **VP-727A** *Audio Switcher* and **VP-727A-BA** *Balanced Audio Switcher* are audio companion switchers for the **VP-747**, and either can operate in conjunction with it and the **VP-727T** *Presentation Switcher Control Panel*.

In particular, the **VP-747**:

- Features Silicon Optix HQV® Video Processing (Hollywood Quality Video) which represents the state-of-the-art in video processing technology, with the highest quality de-interlacing, noise reduction, and scaling performance for both standard-definition and high-definition signals
- Features eight sets of universal INPUT BNC connectors: R/PR, G/Y/CV, B/PB/C, HS/CS, and Vs. Each set can be programmed to operate as: composite video, s-Video, component video<sup>2</sup>, RGsB/YUV, RGBS, or RGBHV
- Includes two DVI / HDMI<sup>3</sup> inputs (for input 1 and input 2) that support up to 1.65 / 2.25Gbps bandwidth per graphic channel<sup>4</sup>
- Is HDTV Compatible and HDCP compliant<sup>5</sup>
- Scales the selected sources to DVI / HDMI, RGBHV (Y, Pb, Pr) and VGA outputs simultaneously
- Has dual scalers—for “live” seamless transitions from one source to another—with two independent outputs: a PREVIEW OUT and a PROGRAM OUT (see [Section 8.2](#)). The PREVIEW output—including an OSD menu for making adjustments—is for determining how the scaled output will look before displaying live during a presentation, as well as for setting the special effects that harmonize the transition when changing between sources. Both outputs have separate sets of connectors for DVI / HDMI, VGA (a 15-pin HD computer graphics video connector), and RGBHV / YPbPr (on BNC connectors)

---

1 Recommended for advanced users only – non-standard settings may not be recognized by the display device

2 Sometimes called YUV, or Y, B-Y, R-Y, or Y, Pb, Pr. The component input type (HDTV or YCbCr) may be set as HD or SD

3 The HDMI connector connects to a DVD source via the Kramer ADC DM/HF adapter

4 Suitable for resolutions up to UXGA at 60Hz, and for all HD resolutions

5 The HDCP (High Definition Content Protection) license agreement allows copy-protected data on the HDMI input to pass only to the HDMI output

- Features eight PREVIEW input buttons for switching a selected input to the PREVIEW output and eight PROGRAM input buttons for switching a selected input to the PROGRAM output
- Includes two transition modes (accessible via the OSD): the Swap mode and the Follow mode. When pressing the TAKE button in the Swap mode, the preview and program inputs switch positions; when pressing in the Follow mode, the program input follows the preview input
- Scales and zooms (to up to 400% of the original size)
- Offers high quality de-interlacing 3:2/2:2 pull down<sup>1</sup>
- Features K-IIT XL™ Picture-in-Picture Image Insertion Technology with ultra stable picture-in-picture, picture-and-picture, and split screen capability for both the PREVIEW and the PROGRAM outputs. Any video source can be inserted into or positioned next to a computer graphics video source or vice versa with window positioning and sizing controls<sup>2</sup>
- Saves all settings in non-volatile memory in the unit
- Supports firmware upgrade via USB
- Features a sophisticated front panel lockout<sup>3</sup>
- Features a Take button for executing preview to program switching (with transition effects, which include cuts, fades, and wipes<sup>4</sup>)
- Has ProcAmp<sup>5</sup> controls for both outputs
- Has multi-standard video support: PAL, SECAM, and NTSC (3.58/4.43)
- Has a built-in Time Base Corrector that stabilizes video sources with unstable sync
- Features multiple color space, outputting RGB or YUV
- Supports embedded audio on the HDMI inputs and outputs
- Digitally reprocesses the signal to correct mastering errors, and regenerates the video at a chosen line and pixel rate format, providing, for example, native-resolution video for LCD, DLP and Plasma displays
- Facilitates scaling of graphics resolutions to other resolutions
- Incorporates a unique graphics-scaling engine with image enhancement algorithms, which are built into the firmware

---

<sup>1</sup> Accommodates the frame-rate of a converted movie (24 frames per second) to video frequencies (25 frames per second (PAL); 30 frames per second (NTSC))

<sup>2</sup> See [Table 5](#)

<sup>3</sup> See [Section 8.5](#)

<sup>4</sup> The direction of the wipe may be selected by the user. The speed of each transition can be adjusted

<sup>5</sup> Processing amplification enables adjustment of different video and audio signal parameters

- Is specifically designed to improve video quality by reducing chroma and temporal noise
- Reduces digital artifacts such as mosquito and block noise
- Comes in a rugged, professional 19" 3U rack-mountable metal enclosure
- Uses a universal 100-240VAC automatic power supply, and rear panel power switch

Control the **VP-747** via the:

- Front panel and a user-friendly menu-driven OSD (see [Section 9.1](#))
- High contrast LCD Display (see [Section 9.2](#))
- IR remote control transmitter (see [Section 9.3](#))
- ETHERNET/RS-232 (see [Section 9.4](#))
- Kramer **VP-727T Presentation Switcher Control Panel**<sup>1</sup>

### 3.1 About HDMI

High-Definition Multimedia Interface (HDMI) is an uncompressed all-digital<sup>2</sup> audio/video interface, widely supported in the entertainment and home cinema industry. It delivers the highest high-definition image and sound quality. Note that Kramer Electronics Limited is an HDMI Adopter and an HDCP Licensee.

In particular, HDMI<sup>3</sup>:

- Provides a simple<sup>4</sup> interface between any audio/video source, such as a set-top box, DVD player, or A/V receiver and video monitor, such as a digital flat LCD / plasma television (DTV), over a single lengthy<sup>5</sup> cable
- Supports standard, enhanced, high-definition video, and multi-channel digital audio<sup>6</sup> on a single cable
- Transmits all ATSC HDTV standards and supports 8-channel digital audio, with bandwidth to spare to accommodate future enhancements and requirements

---

1 See the separate user manual on our Web site at <http://www.kramerelectronics.com>

2 Ensuring an all-digital rendering of video without the losses associated with analog interfaces and their unnecessary digital-to-analog conversions

3 HDMI, the HDMI logo and High-Definition Multimedia Interface are trademarks or registered trademarks of HDMI licensing LLC

4 With video and multi-channel audio combined into a single cable, the cost, complexity, and confusion of multiple cables currently used in A/V systems is reduced

5 HDMI technology has been designed to use standard copper cable construction at up to 15m

6 HDMI supports multiple audio formats, from standard stereo to multi-channel surround-sound. HDMI has the capacity to support Dolby 5.1 audio and high-resolution audio formats



- Benefits consumers by providing superior, uncompressed digital video quality via a single cable<sup>1</sup>, and user-friendly connector
- Is backward-compatible with DVI (Digital Visual Interface)
- Supports two-way communication between the video source (such as a DVD player) and the digital television, enabling new functionality such as automatic configuration and one-button play

HDMI has the capacity to support existing high-definition video formats (720p, 1080i, and 1080p/60), standard definition formats such as NTSC or PAL, as well as 480p and 576p.

Achieving the best performance means:

- Connecting only good quality connection cables, thus avoiding interference, deterioration in signal quality due to poor matching, and elevated noise levels (often associated with low quality cables)
- Avoiding interference from neighboring electrical appliances, making sure not to block the ventilation holes, and positioning your **VP-747** away from moisture, excessive sunlight and dust

#### 4 Your VP-747 Universal Presentation Matrix Switcher / Scaler

[Figure 1](#) and [Table 1](#) define the front panel of the **VP-747**:

---

<sup>1</sup> HDMI provides the quality and functionality of a digital interface while also supporting uncompressed video formats in a simple, cost-effective manner

Your VP-747 Universal Presentation Matrix Switcher / Scaler

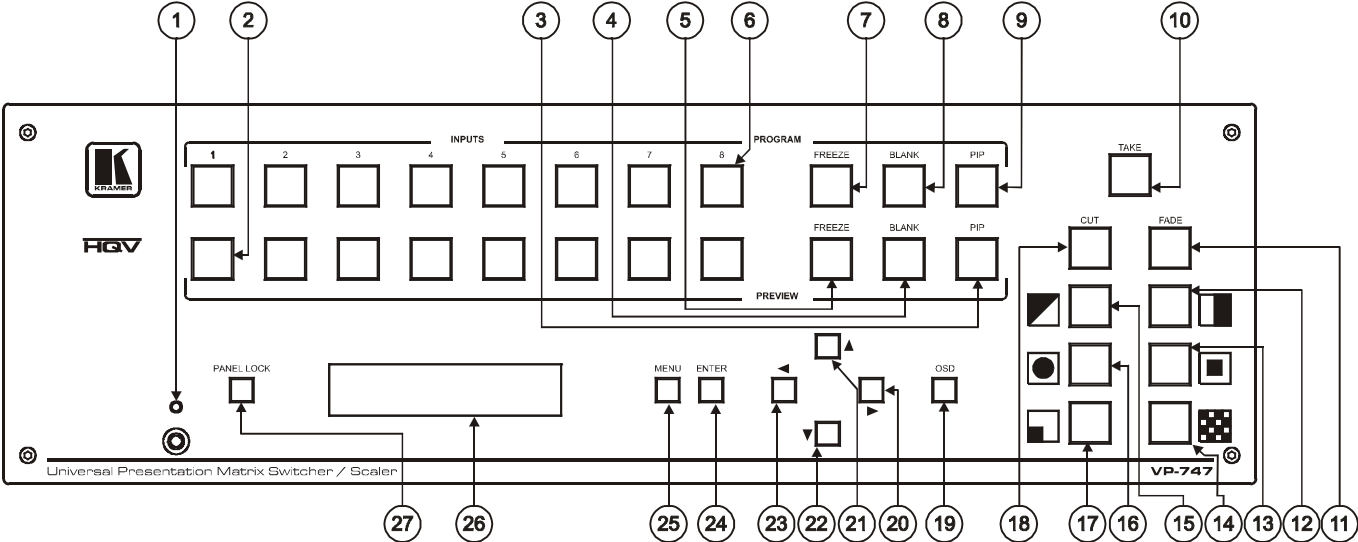

Figure 1: VP-747 Universal Presentation Matrix Switcher / Scaler Front Panel

Table 1: Front Panel VP-747 Universal Presentation Matrix Switcher / Scaler Features











| #  | Feature                           | Function  |   |
|----|-----------------------------------|---|---|
| 1  | IR Receiver / LED                 | Green when ON; red when OFF <sup>1</sup>  |   |
| 2  | PREVIEW Buttons                   | INPUTS  | Selects the video source (from 1 to 8) <sup>2</sup> for the Preview output  |
| 3  |                                   | PIP   | Toggles the picture-in-picture function on and off on the Preview output    |
| 4  |                                   | BLANK   | Toggles between a blank screen and the selected input on the preview output |
| 5  |                                   | FREEZE  | Freezes the output video image (toggle) on the Preview output               |
| 6  |                                   | INPUTS  | Selects the video source (from 1 to 8) <sup>2</sup> for the Program output  |
| 7  | PROGRAM Buttons                   | FREEZE  | Freezes the output video image (toggle) on the Program output               |
| 8  |                                   | BLANK   | Toggles between a blank screen and the selected input on the Program output |
| 9  |                                   | PIP   | Toggles the picture-in-picture function on and off on the Program output    |
| 10 | TAKE Button <sup>3</sup>          | Pressing TAKE causes the transition to occur                                      |   |
| 11 | FADE <sup>8</sup> Button          | Selects a dissolved transition from the PREVIEW output to the PROGRAM output      |   |
| 12 | TRANSITION Buttons <sup>3,4</sup> |  | Selects a <b>WIPE</b> transition effect <sup>5</sup>                        |
| 13 |                                   |  | Selects a <b>SQUARE</b> transition effect <sup>7</sup>                      |
| 14 |                                   |  | Selects a <b>CHESSBOARD</b> transition effect <sup>7</sup>                  |
| 15 |                                   |  | Selects a <b>DIAGONAL</b> transition effect <sup>6</sup>                    |
| 16 |                                   |  | Selects a <b>CIRCLE</b> transition effect <sup>7</sup>                      |
| 17 |                                   |  | Selects a <b>CORNER</b> transition effect <sup>6</sup>                      |
| 18 | CUT <sup>8</sup> Button           | Selects an instantaneous transition from the PREVIEW output to the PROGRAM output |   |
| 19 | OSD Button                        | Activates/deactivates access to the OSD Menu on the Preview output                |   |
| 20 | NAVIGATION Buttons                |  | Toggles within each level 2 command / increases the range by one step       |
| 21 |                                   |  | Moves up one step (in the same level) in the OSD menu                       |
| 22 |                                   |  | Moves down one step (in the same level) in the OSD menu                     |
| 23 |                                   |  | Toggles within each level 2 command / decreases the range by one step       |
| 24 | ENTER Button                      | Moves to the next level in the OSD menu   |   |
| 25 | MENU Button                       | Displays the OSD Menu screen (or moves to the previous level in the OSD menu)     |   |
| 26 | LCD STATUS Display                | Displays the status of the unit, and is used for menu navigation                  |   |
| 27 | PANEL LOCK Button                 | Locks/unlocks the front panel <sup>9</sup>  |   |

Figure 2 and Table 2 define the rear panel of the **VP-747**:

1 OFF in this case means that the outputs and the front-panel are disabled

2 From the five BNC (universal) inputs for each of the inputs. The INPUT buttons 1 and 2 can also select the DVI / HDMI sources

3 The effect is only seen in PROGRAM Mode. The PREVIEW screen will blank during the transition

4 Select a specific effect for the transition from the PREVIEW output to the PROGRAM output

5 To choose the direction from where the effect starts: “left to right”, “right to left”, “up” or “down”, see [Section 9.1.2](#)

6 To choose the direction from where the effect starts: “top left”, “bottom left”, “top right” or “bottom right”, see [Section 9.1.2](#)

7 To choose the direction of the effect: “in” or “out”, see [Section 9.1.2](#)

8 Only for setting up the unit for the effect. The effect will only occur when the Take button is pressed

9 Press and hold for about 2 seconds to toggle

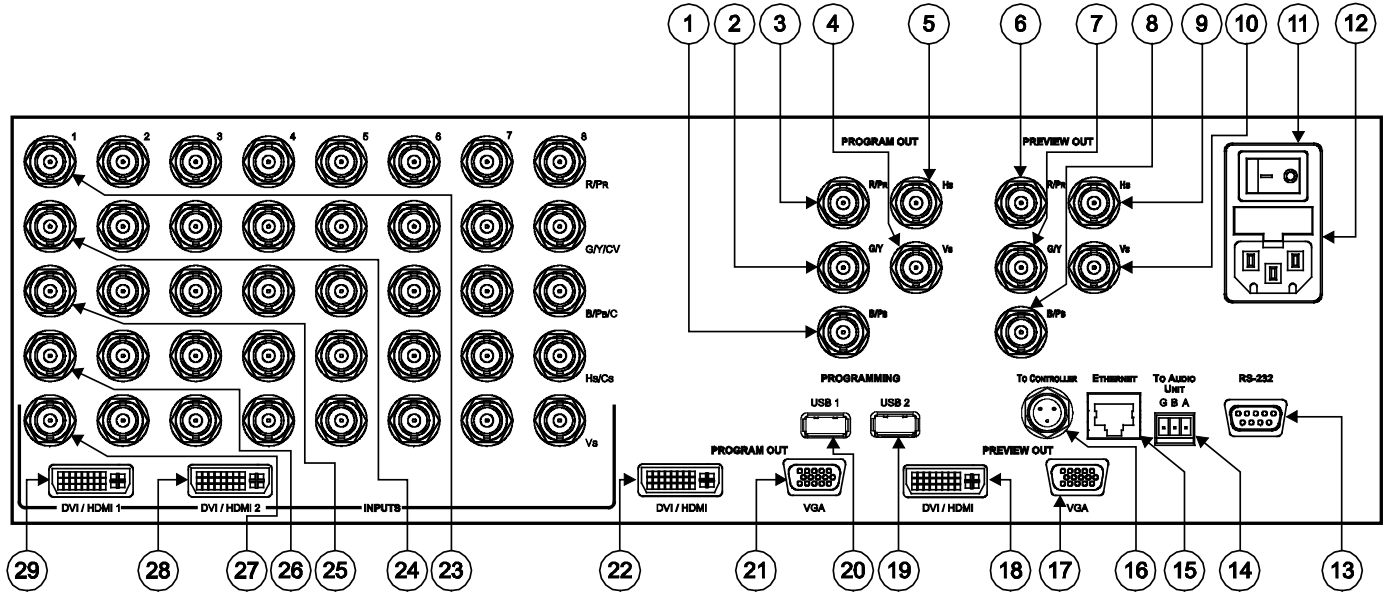

Figure 2: VP-747 Universal Presentation Matrix Switcher / Scaler Rear Panel

Table 2: Rear Panel VP-747 Universal Presentation Matrix Switcher / Scaler Features

| #  | Feature                          | Function   |   |
|----|----------------------------------|--|---|
| 1  | PROGRAM<br>OUT                   | B/Pb BNC Connector   |   |
| 2  |                                  | G/Y BNC Connector  |   |
| 3  |                                  | R/Pr BNC Connector   |   |
| 4  |                                  | Vs BNC Connector   |   |
| 5  |                                  | Hs/Cs BNC Connector  |   |
| 6  | PREVIEW<br>OUT                   | R/Pr BNC Connector   |   |
| 7  |                                  | G/Y BNC Connector  |   |
| 8  |                                  | B/Pb BNC Connector   |   |
| 9  |                                  | Hs/Cs BNC Connector  |   |
| 10 |                                  | Vs BNC Connector   |   |
| 11 | POWER Switch                     |  | Illuminated switch for turning the unit ON or OFF   |
| 12 | Power Connector with FUSE        |  | AC connector enabling power supply to the unit  |
| 13 | RS-232 9-pin D-sub Connector     |  | Connects to PC or Serial Controller   |
| 14 | TO AUDIO UNIT Port               | Connects to the Kramer <b>VP-727A Audio Switcher</b> (optional). Pins B (-) and A (+) are for RS-485; pin G may be connected to the Ground or the shield if desired;                     |   |
| 15 | ETHERNET Port                    | Connects to your LAN <sup>2</sup>  |   |
| 16 | TO CONTROLLER Mini XLR Connector | Connects to the Kramer <b>VP-727T Presentation Switcher Control Panel</b> (optional). Pins B (-) and A (+) are for RS-485; pin G may be connected to the Ground or the shield if desired |   |
| 17 | PREVIEW OUT                      | VGA 15-pin HD Connector  | Connects to a VGA (analog interface) graphics acceptor  |
| 18 |                                  | DVI / HDMI Connector   | Connects to a DVI or HDMI <sup>3</sup> acceptor   |
| 19 | PROGRAMMING                      | USB 2 Connector  | For Program firmware download   |
| 20 |                                  | USB 1 Connector  | For Preview firmware download   |
| 21 | PROGRAM<br>OUT                   | VGA 15-pin HD Connector  | Connects to a VGA (analog interface) graphics acceptor  |
| 22 |                                  | DVI / HDMI Connector   | Connects to a DVI or HDMI <sup>3</sup> acceptor   |
| 23 | INPUTS<br>(from 1 to 8)          | R/Pr BNC Connector   | Connects to the R or Pr output of the RGB, RGBHV, RGBS, or component video <sup>1</sup> source  |
| 24 |                                  | G/Y/CV BNC Connector   | Connects to the G, Y or CV output of the RGB, RGBHV, RGBS, component video <sup>1</sup> , composite video, or s-Video <sup>4</sup> source |
| 25 |                                  | B/Pb/C BNC Connector   | Connects to the B, Pb or C output of the RGB, RGBHV, RGBS, component video <sup>1</sup> or s-Video <sup>4</sup> source                    |
| 26 |                                  | Hs/Cs BNC Connector  | Connects to the horizontal or composite sync RGBHV or RGBS source   |
| 27 |                                  | Vs BNC Connector   | Connects to the vertical sync RGBHV source  |
| 28 | INPUTS                           | DVI / HDMI 2 Connector   | Connect to the DVI/HDMI <sup>3</sup> 2 source   |
| 29 |                                  | DVI / HDMI 1 Connector   | Connect to the DVI/HDMI <sup>3</sup> 1 source   |

1 Sometimes called YUV; Y, B-Y, R-Y; Y, Pb, Pr; or Y, Cb, Cr

2 Local Area Network (that is, computers sharing a common communications line or wireless link, which often share a server within a defined geographic area)

3 Using a DVI/HDMI adapter or the Kramer C-HDMI/DVI HDMI to DVI Single Link (18 +1 pin) cable

4 Made up of the Y on the G/Y/CV connector together with the C on the B/Pb/C connector

## 5 Installing on a Rack

This section describes what to do before installing in a rack and how to rack mount.

### Before Installing in a Rack

|  |                                |
|--|--------------------------------|
| Before installing in a rack, be sure that the environment is within the recommended range: |                                |
| Operating temperature range  | +5° to +45° C (41° to 113° F)  |
| Operating humidity range   | 10 to 90% RHL, non-condensing  |
| Storage temperature range  | -20° to +70° C (-4° to 158° F) |
| Storage humidity range   | 5 to 95% RHL, non-condensing   |



### CAUTION!!

When installing in a 19" rack, avoid hazards by taking care that:

1. It is located within the recommended environmental conditions, as the operating ambient temperature of a closed or multi unit rack assembly may exceed the room ambient temperature.
2. Once rack mounted, enough air will still flow around the machine.
3. The machine is placed straight in the correct horizontal position.
4. You do not overload the circuit(s). When connecting the machine to the supply circuit, overloading the circuits might have a detrimental effect on overcurrent protection and supply wiring. Refer to the appropriate nameplate ratings for information. For example, for fuse replacement, see the value printed on the product label.
5. The machine is earthed (grounded) in a reliable way and is connected only to an electricity socket with grounding. Pay particular attention to situations where electricity is supplied indirectly (when the power cord is not plugged directly into the socket in the wall), for example, when using an extension cable or a power strip, and that you use only the power cord that is supplied with the machine.

### How to Rack Mount

To rack-mount a machine:

1. Attach both ear brackets to the machine. To do so, remove the screws from each side of the machine (3 on each side), and replace those screws through the ear brackets.

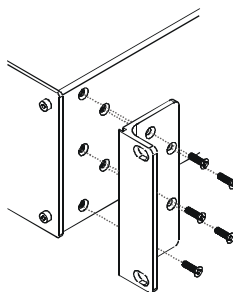

2. Place the ears of the machine against the rack rails, and insert the proper screws (not provided) through each of the four holes in the rack ears.

Note that:

- **In some models, the front panel may feature built-in rack ears**
- Detachable rack ears can be removed for desktop use
- Always mount the machine in the rack before you attach any cables or connect the machine to the power
- If you are using a Kramer rack adapter kit (for a machine that is not 19"), see the Rack Adapters user manual for installation instructions (you can download it at: <http://www.kramerelectronics.com>)

## 6 Connecting the VP-747

The **VP-747** is a universal presentation matrix switcher / scaler that lets you choose what sources to connect to the inputs. For example, you can connect just five sources: an RGBHV source, two DVI / HDMI sources, an HDTV source and an RGBS source (as the example in [Figure 3](#) shows).

To connect<sup>1</sup> the **VP-747** as illustrated in the example in [Figure 3](#), do the following:

1. Connect the following video sources:
  - An HDMI source to the INPUT DVI / HDMI 1 connector
  - An HDMI source to the INPUT DVI / HDMI 2 connector
  - An HDTV satellite receiver source to the R/PR, G/Y/CV, and B/PB/C BNC INPUT 6 connectors (PR/Y/PB)
  - An RGBHV computer graphics source to the R/PR, G/Y/CV, B/PB/C, HS/CS and V BNC INPUT 8 connectors (R, G, B, H, V)
2. Connect the PROGRAM OUT:
  - DVI / HDMI connector to the plasma display
  - VGA 15-pin HD connector to the analog display
  - R/PR, G/Y, B/PB, (PR, Y, PB) BNC OUTPUT connectors to the YUV acceptor, for example, a projector (PR, Y, PB)
3. Connect the PREVIEW OUT R/PR, G/Y, B/PB, HS and VS BNC OUTPUT connectors to the display (R, G, B, H, V)
4. Connect the power cord<sup>2</sup>.
5. If required, connect:
  - A PC via RS-232, see [Section 7.1](#)
  - The Kramer **VP-727A Audio Switcher** via the To AUDIO UNIT RS-485 port<sup>3</sup>, see [Section 7.2](#)
  - The Kramer **VP-727T Presentation Switcher Control Panel** via the TO CONTROLLER mini XLR port<sup>3</sup>
  - The ETHERNET port<sup>3</sup>, see [Section 7.4](#)

---

1 Switch OFF the power on each device before connecting it to your VP-747. After connecting your VP-747, switch on its power and then switch on the power on each device

2 We recommend that you use only the power cord that is supplied with this machine

3 Not shown in [Figure 3](#) (see [Section 7.3](#))

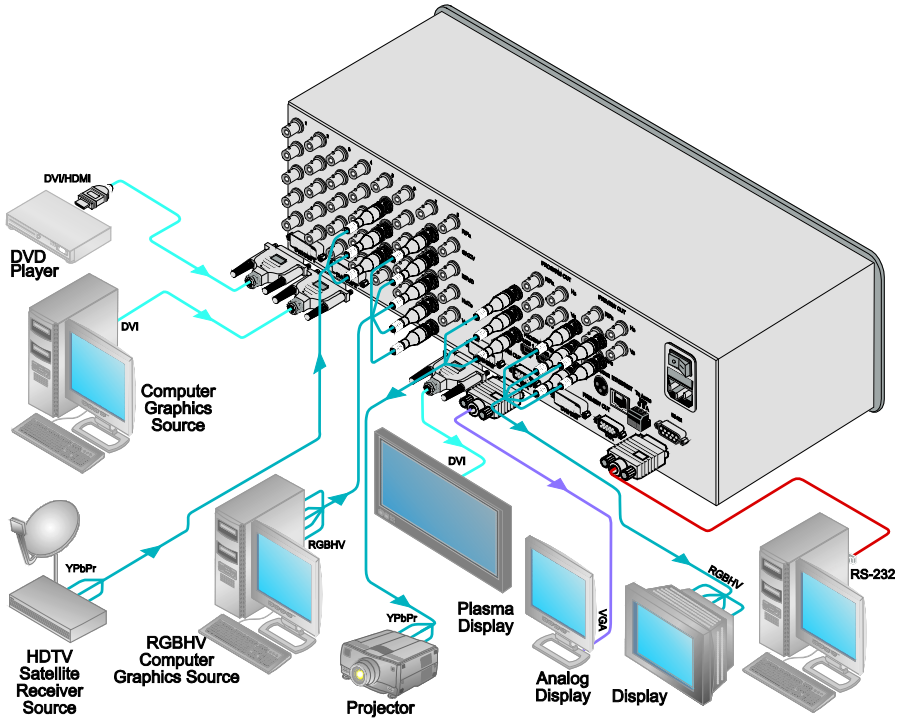

Figure 3: Connecting the VP-747



## 6.1 Connecting Different Source Types

As the **VP-747** is universal, you can connect any type (format) of video to the inputs. [Figure 4](#) and [Table 3](#) show an example of how to connect eight sources to the rear panel of the **VP-747**: an RGBHV source, an HDMI source, a CV source, a Y/C source, a component video source, an HDTV source, an RGBCs source and an RGB source.

Table 3: Connecting the Different Source Types

|        | Input 1: | Input 2: | Input 3: | Input 4: | Input 5:  | Input 6: | Input 7: | Input 8: |
|--------|----------|----------|----------|----------|-----------|----------|----------|----------|
|        | RGBHV    | HDMI     | CV       | Y/C      | Component | HDTV     | RGBCs    | RGB      |
| R/PR   | R        |          |          |          | PR        | PR       | R        | R        |
| G/Y/CV | G        |          | CV       | Y        | Y         | Y        | G        | G        |
| B/PB/C | B        |          |          | C        | PB        | PB       | B        | B        |
| HS/CS  | HS       |          |          |          |           |          | CS       |          |
| VS     | VS       |          |          |          |           |          |          |          |
| HDMI   |          | HDMI     |          |          |           |          |          |          |

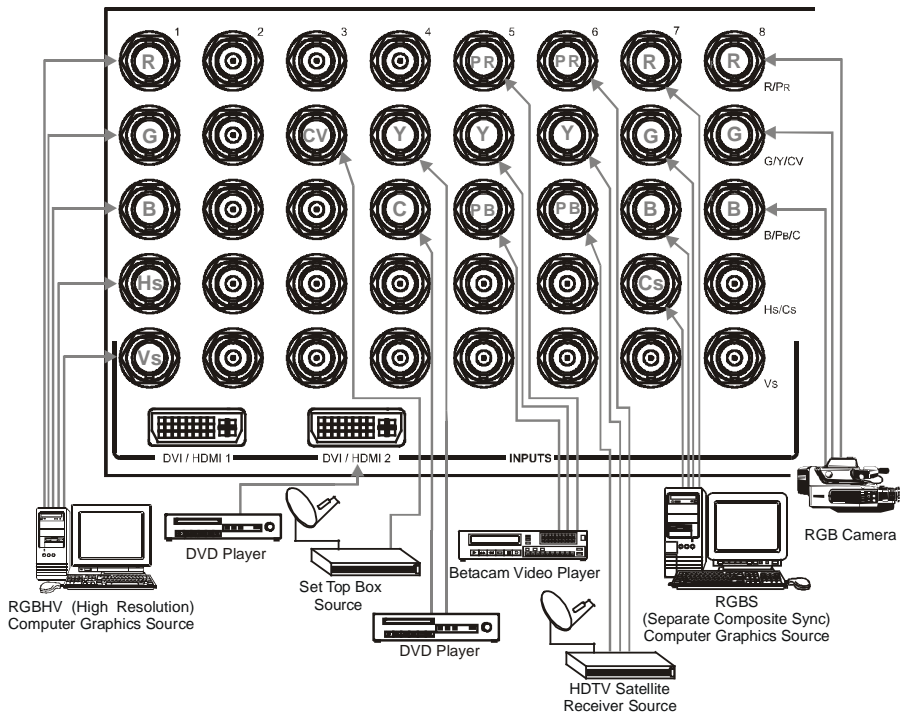

Figure 4: Connecting the INPUTS (an example)

## 6.2 Connecting the Outputs

[Figure 5](#) illustrates an example of the different connection types available for the Preview and Program outputs:

For PROGRAM OUT, connect the:

- R/PR, G/Y, B/PB, (PR, Y, PB) BNC OUTPUT connectors to the YUV acceptor, for example, a projector
- HDMI connector to a plasma display
- VGA a 15-pin HD computer graphics video connector to an analog display

For PREVIEW OUT, connect the:

- HDMI connector to an LCD display
- VGA 15-pin HD computer graphics video connector to an analog display
- R/PR, G/Y, B/PB, HS and VS BNC OUTPUT connectors to a display

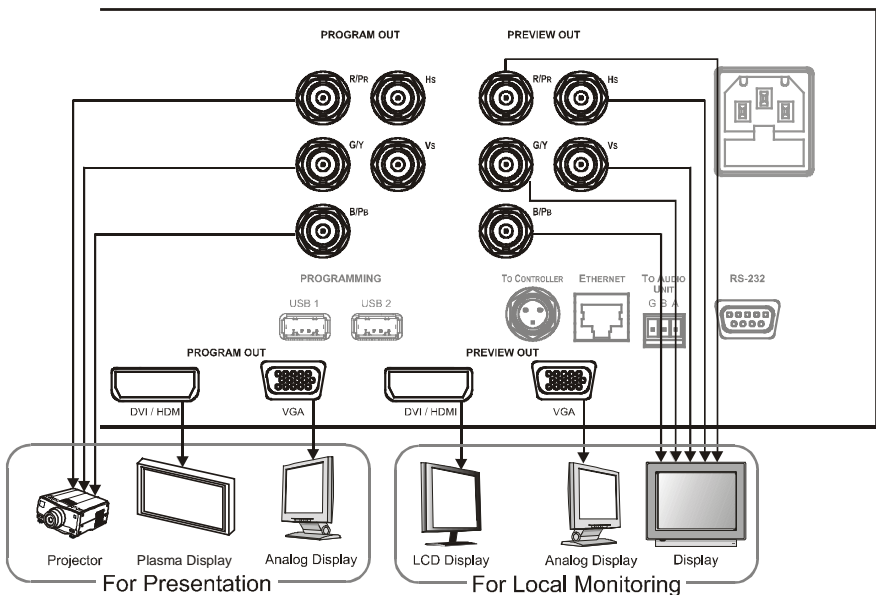

Figure 5: Connecting the PREVIEW OUT / PROGRAM OUT Connectors

## 7 Connecting the VP-747 Control Ports

This section describes how to connect the **VP-747** control ports, that is, the:

- RS-232 port, see [Section 7.1](#)
- TO AUDIO UNIT port, see [Section 7.2](#)
- TO CONTROLLER port, see [Section 7.3](#)
- ETHERNET port, see [Section 7.4](#)

### 7.1 Connecting a PC (via RS-232)

You can connect a PC (or other controller) to the **VP-747** via the RS-232 port for remote control.

To connect a PC to a **VP-747** unit, using the Null-modem adapter provided with the machine (recommended):

- Connect the RS-232 9-pin D-sub rear panel port on the **VP-747** unit to the Null-modem adapter and connect the Null-modem adapter with a 9-wire flat cable to the RS-232 9-pin D-sub port on your PC

To connect a PC to a **VP-747** unit, without using a Null-modem adapter:

- Connect the RS-232 9-pin D-sub port on your PC to the RS-232 9-pin D-sub rear panel port on the **VP-747** unit, forming a cross-connection<sup>1</sup>, as [Figure 6](#) illustrates

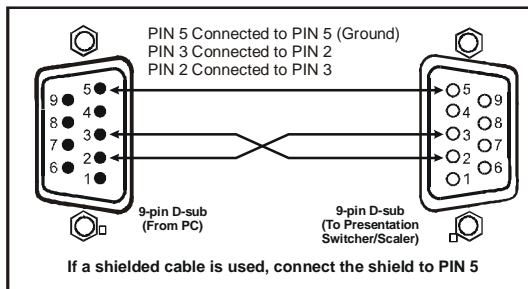

Figure 6: Connecting the PC

<sup>1</sup> Also known as a null-modem connection

## 7.2 Connecting the AUDIO CONTROL Port

The Kramer **VP-727A Audio Switcher** operates in conjunction with the **VP-747**. When connected, the audio switcher signals follow the video signals<sup>1</sup>.

To connect the **VP-747** to the Kramer **VP-727A Audio Switcher** via the TO AUDIO UNIT RS-485 port, as illustrated in the example in [Figure 7](#), do the following:

- Connect the “A” (+) PIN on the AUDIO CONTROL RS-485 rear panel port of the **VP-747** to the A (+) PIN on the RS-485 rear panel port of the **VP-727A** unit
- Connect the “B” (-) PIN on the AUDIO CONTROL RS-485 rear panel port of the **VP-747** to the B (-) PIN on the RS-485 rear panel port of the **VP-727A** unit
- If shielded twisted pair cable is used, the shield may be connected to the “G” (Ground) PIN on one of the units

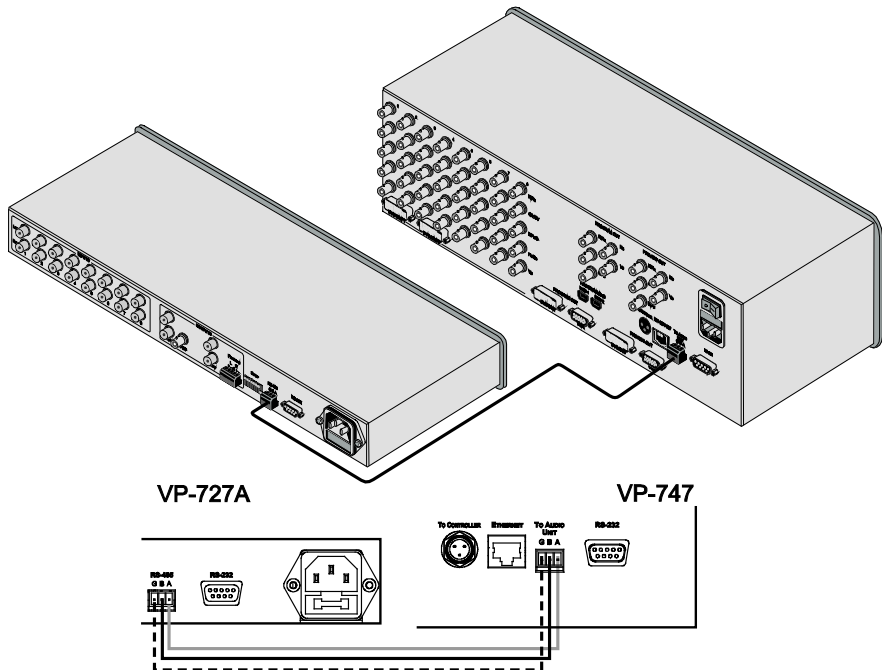

Figure 7: Connecting the VP-727A to the VP-747

<sup>1</sup> See the separate VP-727A user manual on our Web site at <http://www.kramerelectronics.com>

### 7.3 Connecting the VP-747 to the Kramer VP-727T

To connect the **VP-747** to the Kramer **VP-727T Presentation Switcher Control Panel**<sup>1</sup> via the mini XLR connector, as illustrated in, do the following:

- Connect the “A” PIN on the TO CONTROLLER mini XLR connector of the **VP-747** to the A (+) PIN on the RS-485 rear panel port of the **VP-727T** unit
- Connect the “B” (-) PIN on the TO CONTROLLER mini XLR connector of the **VP-747** to the B (-) PIN on the RS-485 rear panel port of the **VP-727T** unit
- If shielded twisted pair cable is used, the shield may be connected to the “G” (Ground) PIN on one of the units

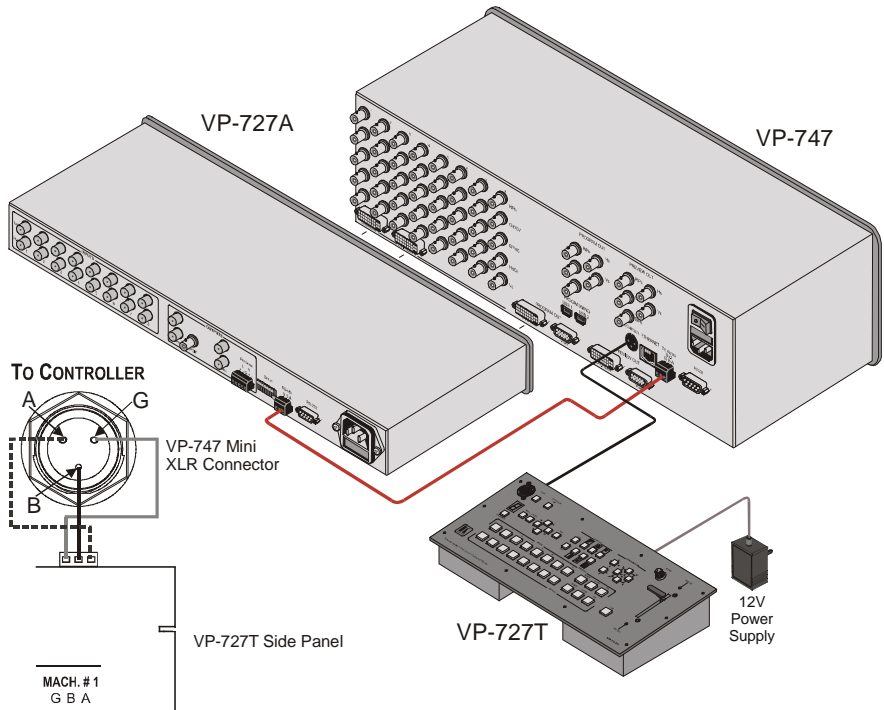

Figure 8: Connecting the VP-747 to the VP-727T

It is recommended that the PROGRAM and PREVIEW are set with the same output resolutions for the best results when working with the T-bar

<sup>1</sup> See the separate VP-727T user manual on our Web site at <http://www.kramerelectronics.com>

## 7.4 Connecting the VP-747 via the ETHERNET port

To connect the **VP-747** via the ETHERNET port, do the following:

Connect the ETHERNET port of the **VP-747** to the LAN port of your PC, via a crossover cable with RJ-45 connectors.

If connecting the ETHERNET port of the **VP-747** to the LAN port on a network hub or network router, use a straight-through cable with RJ-45 connectors.

## 8 Understanding the VP-747

This section describes the:

- UNIVERSAL inputs, see [Section 8.1](#)
- PREVIEW/PROGRAM outputs, see [Section 8.2](#)
- Switching/Scaling of an input, see [Section 8.3](#)
- PIP feature, see [Section 8.4](#)
- Panel Lock, see [Section 8.5](#)

### 8.1 Understanding the UNIVERSAL Inputs

The **VP-747** has eight sets of inputs<sup>1</sup>; each set can be programmed to operate as composite video, s-Video, component video, RGB/YUV, RGBS, RGsB, or RGBHV. INPUT 1 and INPUT 2 can also accept DVI/HDMI inputs.

The **VP-747** is a **universal** presentation matrix switcher / scaler: you choose what type of source to connect to each input. You can connect different video types or the same or similar video types. See the examples in [Figure 3](#) and [Figure 4](#) in [Section 6](#).

### 8.2 Understanding the PREVIEW/PROGRAM Outputs

The **VP-747** has two outputs: a PREVIEW output, and a PROGRAM output. Each of these outputs functions independently and has DVI / HDMI connectors and VGA connectors, as well as sets of five BNC connectors<sup>2</sup>: R/Pr, G/Y, B/Pb, Hs, and Vs.

The HDMI signal is usually HDCP protected. It is therefore recommended to use a display that is HDCP compliant, otherwise the HDMI output will not appear on the screen

---

<sup>1</sup> Each set consists of five BNC connectors: R/Pr, G/Y/CV, B/Pb/C, Hs/Cs, and Vs

<sup>2</sup> Used to output one of the following: RGB, RGBHV, or component video

Using the **PREVIEW** output, you can:

- See how the scaled output will look before displaying live during a presentation. As the example in [Figure 9](#) illustrates, after seeing how the RGB source looks when scaled to HDMI, it can be interchanged with the YUV source, seamlessly, using an elaborate (in this case chessboard) transition effect
- Harmonize transition to the **PROGRAM** output after determining the look and feel when in the **PREVIEW** output
- Use the OSD menu to make adjustments and choose the settings
- Set the transition, choosing one of any eight special effects

Using the **PROGRAM** output, after pressing the **TAKE** button, you can see the transition<sup>1</sup>. The **PREVIEW** output is not available during the transition period.

---

<sup>1</sup> After making some changes in the unit (for example, selecting a new input to the **PREVIEW** output), the **TAKE** button will be turned off (not illuminated) momentarily (until the unit successfully locks to this input). The **TAKE** button should not be pressed until it lights up again

1. In this example an RGBS source is connected to input 2, and a Component source is connected to input 3. Set the OSD Settings as follows:

The PROGRAM INPUT button 3 and the PREVIEW INPUT button 2 illuminate:

2. During the presentation, the Component source is outputted via the DVI/HDMI PROGRAM OUT connector. Before changing to the RGBS source, the demonstrator previews how that source currently looks on his local display:

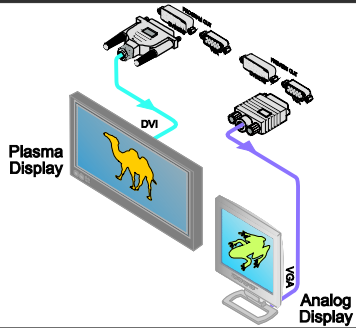

3. Pressing the Chessboard button and then the TAKE button causes the transition to occur. The PROGRAM INPUT button 2 illuminates to correspond with the PREVIEW INPUT button 2. The RGBS and component sources are swapped on the PREVIEW and PROGRAM outputs:

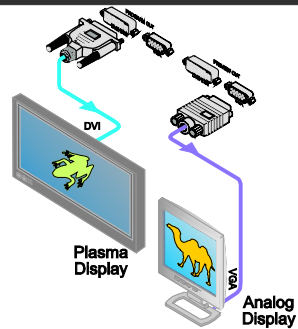

Figure 9: Example showing the use of the PREVIEW and PROGRAM Output



### 8.2.1 The Transition from Preview to Program

The transition can occur in one of two modes<sup>1</sup>:

- The Swap<sup>2</sup> mode (shown in [Figure 9](#)), in which the PREVIEW input buttons and the PROGRAM input buttons switch places after pressing the TAKE button. For example, in [Figure 9](#) the PROGRAM input button 3 would switch to 2 and the PREVIEW input button 2 would switch to 3, so the RGBS source is displayed on the PROGRAM screen and the Component source is displayed on the PREVIEW screen.
- The Follow mode in which the PROGRAM input button is switched to the same position as the PREVIEW input button after the TAKE button is pressed

### 8.3 Switching/Scaling of an Input

The **VP-747** scales the selected sources<sup>3</sup> to HDMI, RGBHV or YUV and VGA simultaneously. It switches seamlessly between sources using the selected special effects, which include cuts, fades, and wipes. Select the appropriate source (from channel 1 to 8) via the Input command in both the Preview Setting OSD screen and/or the Program Setting OSD screen (see [Section 9.1.1](#)), via the IR or front panel pushbuttons, or via the serial or Ethernet control.

---

1 As selected via the Transition OSD Menu, see [Section 9.1.2](#)

2 Swap mode is the default for the VP-747

3 Composite video, s-Video, component video (sometimes called YUV or Y, B-Y, R-Y or Y, Pb, Pr ), RGB/YUV, RGBS, RGsB, or RGBHV

## 8.4 Understanding the PIP Button Feature

The Picture-in-Picture inserter (PIP) is used for the simultaneous display of video and graphic sources<sup>1</sup>, and lets you display an inserted video PIP source over a graphic source<sup>2</sup>, or an inserted graphic PIP source over a video source<sup>3</sup>, compliant to [Table 4](#). Both the Preview and Program outputs can support the PIP function.

Table 4: PIP Source Appearance Availability

|         |             | PIP Source |     |         |         |      |      |       |      |
|---------|-------------|------------|-----|---------|---------|------|------|-------|------|
|         |             | VIDEO      |     | GRAPHIC |         |      |      |       |      |
|         | Main Source | CV         | YC  | COMP    | RGB/YUV | RGBS | RGsB | RGBHV | HDMI |
| VIDEO   | CV          | No         | No  | Yes     | Yes     | Yes  | Yes  | Yes   | Yes  |
|         | YC          | No         | No  | Yes     | Yes     | Yes  | Yes  | Yes   | Yes  |
| GRAPHIC | COMP        | Yes        | Yes | No      | No      | No   | No   | No    | No   |
|         | RGB/YUV     | Yes        | Yes | No      | No      | No   | No   | No    | No   |
|         | RGBS        | Yes        | Yes | No      | No      | No   | No   | No    | No   |
|         | RGsB        | Yes        | Yes | No      | No      | No   | No   | No    | No   |
|         | RGBHV       | Yes        | Yes | No      | No      | No   | No   | No    | No   |
|         | HDMI        | Yes        | Yes | No      | No      | No   | No   | No    | No   |

Select the PIP source (from channel 1 to 8), via the PIP source command in both the Preview Setting OSD screen and/or the Program Setting OSD screen.

### Activate the PIP Feature by:

- Pressing the PIP front panel button
- Switching on the PIP functionality via the OSD Menu (see section [Table 5](#))
- Pressing the PIP key on the remote control transmitter (see [Section 9.3](#))
- Selecting the Serial or the Ethernet port
- Pressing the PIP button on the **VP-727T Presentation Switcher Control Panel**

### Use the OSD menu (see [Section 9.1.1](#)) to:

- Select the PIP type
- Resize the PIP
- Create a PIP frame

<sup>1</sup> Since the HDMI signal is HDCP protected, an HDMI signal cannot appear on a display that is not HDCP compliant

<sup>2</sup> For example, a composite video or s-Video PIP source inserted over a component, RGB/YUV, RGBS, RGsB, or RGBHV graphic source

<sup>3</sup> For example, a component (graphics), RGB/YUV, RGBS, RGsB, or RGBHV graphic PIP source inserted over a composite video, s-Video, or component (video) video source

## 8.5 Locking and Unlocking the Front Panel

To prevent changing the settings accidentally or tampering with the unit via the front panel buttons, lock your **VP-747**. Unlocking releases the protection mechanism. When the front panel is locked, control is still available via RS-232, the ETHERNET, and/or the CONTROL connector.

To lock the **VP-747**:

- Press and hold for a few seconds the PANEL LOCK button<sup>1</sup> on the front panel  
The front panel is locked and the PANEL LOCK button is illuminated.  
Pressing a button will have no effect

To unlock the **VP-747**:

- Press and hold for a few seconds the illuminated PANEL LOCK button<sup>1</sup> on the front panel  
The front panel unlocks and the PANEL LOCK button is no longer illuminated

For a description of the Save Lock and Input Lock OSD functions, see [Section 9.1.4](#).

---

<sup>1</sup> Or the Lock key on the infrared remote control transmitter (see [Figure 19](#))

## 9 Operating the VP-747

You can operate the **VP-747** via the:

- OSD Menu, see [Section 9.1](#)
- LCD Display, see [Section 9.2](#)
- Infrared Remote Control Transmitter, see [Section 9.3](#)
- ETHERNET/RS-232, see [Section 9.4](#)

### 9.1 Operating via the OSD MENU Screen

The OSD superimposes a menu on the Preview screen from which you can control your **VP-747**. When the OSD front panel button is on, pressing the MENU button on the front panel or the Menu key on the infrared remote control transmitter displays the first OSD screen<sup>1</sup>, the “Preview Setting” screen. If the OSD is off, pressing the MENU button on the front panel or the Menu key on the infrared remote control transmitter will not display the “Menu screen”. In this case, you can navigate via the front panel LCD.

[Figure 10](#) defines the six interactive icons:



Figure 10: Menu Screen Icons

#### 9.1.1 Preview and Program Setting Commands

[Figure 11](#) and [Table 5](#) define the Preview and Program Setting commands:

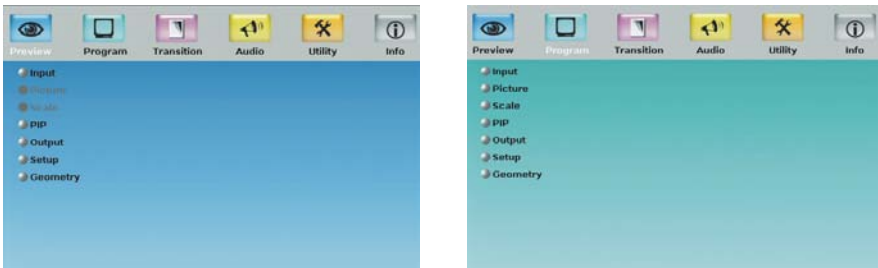

Figure 11: Preview and Program Setting OSD Menus

<sup>1</sup> Or the last used OSD screen

Table 5: Preview and Program Setting OSD Menus

| Setting                                | Function  | Selection/Range   | Default   |
|--|---|---|-----------|
| <b>Input Sub-menu</b>                  |   |   |           |
| Source                                 | Select the input source   | Channel 1 to 8  | Channel 1 |
| Type                                   | Set the video type  | RGBHV, RGBS (PC/Video), RGsB (PC/Video), YCbCr, Y/C or video, HDMI (for input 1 and input 2 only) | RGBHV     |
| Video Standard                         | Set the Video standard  | Auto, NTSC, PAL, PAL-M, PAL-N, NTSC 4.43, SECAM or PAL 60   | Auto      |
| H-Position <sup>1</sup>                | Set the horizontal position <sup>2</sup>  |   |           |
| V-Position <sup>1</sup>                | Set the vertical position   |   |           |
| Frequency <sup>1</sup>                 | Adjust the frequency <sup>3</sup>   |   |           |
| Phase <sup>4</sup>                     | Adjust the phase  | 0 to 31   | 0         |
| Auto Image                             | Assesses the image and improves the quality accordingly, by automatically adjusting the phase, frequency and position. Upon completion, the relevant OSD values are updated (H-Position, V-Position, Phase and Frequency) |   |           |
| Overscan                               | Allows stretching of the outputted picture  | On or Off   | On        |
| <b>Picture Sub-menu</b>                |   |   |           |
| Brightness                             | Adjust the brightness   | -50 to 50   | 0         |
| Contrast                               | Adjust the contrast   | -50 to 50   | 0         |
| Color                                  | Adjust the color  | -50 to 50   | 0         |
| Hue                                    | Adjust the hue  | -180 to 180   | 0         |
| Sharpness                              | Adjust the sharpness  | -50 to 50   | 0         |
| Output Gamma                           | Adjust the gamma  | 1 to 4  | 1         |
| Film Mode                              | Set the film mode   | Auto, Video or Film   | Auto      |
| Temporal NR <sup>5</sup>               | Set the temporal noise reduction level  | Off, Low, Medium or High  | High      |
| Mosquito NR <sup>5</sup>               | Set the Mosquito noise reduction level  | Off, Low, Medium, High  | Low       |
| Block NR <sup>5</sup>                  | Set the block noise reduction level:  | Off or On   | High      |
| Detail Enhancement <sup>5</sup>        | Set the detail enhancement  | Off, Low, Medium or High  | Off       |
| Luma Transition Enhance <sup>5</sup>   | Set the luminance transition enhance level:   | Off, Low or High  | Low       |
| Chroma Transition Enhance <sup>5</sup> | Set the chrominance transition enhance level:   | Off, Low or High  | Low       |

<sup>1</sup> The range changes according to the input mode

<sup>2</sup> For UXGA and component video inputs

<sup>3</sup> For UXGA inputs

<sup>4</sup> Only for a VGA Source

<sup>5</sup> You do not have to press ENTER after selecting the desired parameter to change it

## Operating the VP-747

| Setting                  | Function  | Selection/Range  | Default            |
|--------------------------|---|--|--------------------|
| <b>Scale</b>             |   |  |                    |
| Aspect Ratio             | Set the aspect ratio                                  | Best Fit <sup>1</sup> , Letterbox, Follow Output <sup>2</sup> , Virtual Wide, Follow Input <sup>3</sup> , Custom | Best fit           |
| H-Pan <sup>4</sup>       | Horizontal pan  | -16 to 16  | 0                  |
| V-Pan <sup>4</sup>       | Vertical pan  | -16 to 16  | 0                  |
| H-Zoom <sup>4</sup>      | Horizontal zoom                                       | -8 to 8  | 0                  |
| V-Zoom <sup>4</sup>      | Vertical zoom   | -8 to 8  | 0                  |
| Zoom                     | Set the Zoom <sup>5</sup> :                           | 100%, 150%, 200%, 225%, 250%, 275%, 300%, 325%, 350%, 375%, 400%, Custom   | 100                |
| Custom Zoom <sup>6</sup> | Set the zoom:   | from 0 to 32 (this range is equivalent to 100% to 400%)  | 0                  |
| Zoom H-Pan               |   | -16 to 16  | 0                  |
| Zoom V-Pan               |   | -16 to 16  | 0                  |
| <b>PIP</b>               |   |  |                    |
| On/Off                   | Activate/deactivate the PIP feature <sup>7</sup>      | On/Off   | Off                |
| Type                     | Select the PIP type                                   | Picture-In-Picture, Picture + Picture <sup>8</sup> or Split  | Picture-In-Picture |
| Source                   | Select the PIP source <sup>9</sup> :                  | Channel 1 to Channel 8   |                    |
| PIP Size                 | Select the PIP size                                   | 1/25, 1/16, 1/9, 1/4, or Custom  | 1/4                |
| H - Position             | Set the horizontal position of the PIP on the display | 0 to 128   | 3                  |
| V - Position             | Set the vertical position of the PIP on the display   | 0 to 128   | 0                  |
| H - Size                 | Set custom size <sup>10</sup>                         | 1 to 255   | 14                 |
| V - Size                 | Set custom size <sup>10</sup>                         | 1 to 255   | 5                  |
| Frame                    | Turn the PIP frame                                    | On or Off  | On                 |
| Frame Color              | Select the color of the PIP frame                     | Red, Green or Blue   | Blue               |

1 The best possible compromise between the input and the output aspect ratios without distorting or cropping the picture

2 Scales the picture to fill the entire output screen

3 Shows the picture without scaling it (pixel-to-pixel mapping)

4 Available when selecting Custom aspect ratio

5 The zoom feature is disabled in cases such as when the aspect ratio is set to custom or when the PIP feature is on

6 This function is available after setting the Zoom to custom

7 When PIP is activated and that input is not connected, the PIP window will appear black. If the zoom function is ON, the OSD prompts "cancel zoom?"

8 Maintains the aspect ratio

9 When changing the PIP source, the display fades through black

10 The actual range depends upon the input resolution

## Operating the VP-747

| Setting             | Function  | Selection/Range  | Default       |
|---------------------|---|--|---------------|
| <b>Output</b>       |   |  |               |
| Resolution          | 640x480x60Hz, 640x480x75Hz, 800x600x50Hz, 800x600x60Hz, 800x600x75Hz, 832x624x60Hz, 852x480x60Hz, 1024x768x50Hz, 1024x768x60Hz, 1024x768x75Hz, 1280x768x50Hz, 1280x768x60Hz, 1280x720x60Hz, 1280x800x60Hz, 1280x1024x50Hz, 1280x1024x60Hz, 1280x1024x75Hz, 1366x768x50Hz, 1366x768x60Hz, 1400x1050x50Hz, 1400x1050x60Hz, 1440x900x60Hz, 1600x1200x50Hz, 1600x1200x60Hz, 1680x1050x60Hz, 1920x1080x50Hz, 1920x1080x60Hz, 1920x1200x60Hz, 480px60Hz, 576px60Hz, 720px50Hz, 720px60Hz, 1080ix50Hz, 1080ix60Hz, 1080px50Hz, 1080px60Hz, 1080p@24Hz or Custom (from 1 to 4) <sup>1</sup> |  | 1024x768x60Hz |
| HQV Color Setting   | Set the Red, Green, Blue, Cyan, Magenta and Yellow saturation   | -100 to 100  | 0             |
| <b>Setup</b>        |   |  |               |
|                     | Input Mode Setting (see <a href="#">Figure 12</a> )   |  |               |
|                     | Output mode setting (see <a href="#">Figure 13</a> )  |  |               |
| <b>Geometry</b>     |   |  |               |
| Application         | Select the output application   | Keystone, Anyplace or Rotation   | keystone      |
| Location            | Select the location of the display  | Front, Ceiling, Rear or Rear ceiling   | Front         |
| Horizontal Keystone | Adjust the horizontal keystone <sup>2</sup>   | -40 to 40  | 0             |
| Vertical Keystone   | Adjust the vertical keystone <sup>3</sup>   | -30 to 30  | 0             |
| Diagonal Projection | Move the location of each corner of the display separately <sup>4</sup>   | Top Left, Top Right, Bottom Left, Bottom Right or Reset (to reset diagonal projections settings) | Top Left      |
| Pincushion/Barrel   | Adjust the pincushion or barrel appearance of the screen <sup>5</sup>   | -20 to 20  | 0             |
| Rotation            | Rotate the display clockwise or counterclockwise (in 1° increments)   | -180 to 180  | 0             |
| Reset all           | Resets the geometry settings to their default values  |  |               |

<sup>1</sup> If the custom resolution is set to be the same as the default resolution, the scaler refers to the default resolution

<sup>2</sup> If the projector is located at an angle to the left or right of the screen

<sup>3</sup> If the projector is located at an angle above or below the screen

<sup>4</sup> Horizontally and vertically

<sup>5</sup> For projection onto curved surfaces

9.1.1.1 Preview and Program Input and Output Settings

Figure 12 and Table 6 define the input Mode Setting:



Figure 12: Input Mode Setting Screen

Table 6: Input Mode Functions

| Setting      | Function                      | Range         | Default |
|--------------|-------------------------------|---------------|---------|
| Custom Input | Set custom values             | Custom 1 to 4 |         |
| HT           | Horizontal Total              |               | 1344    |
| HW           | Horizontal sync pulse width   |               | 136     |
| HS           | Horizontal active start point |               | 296     |
| HA           | Horizontal active region      |               | 1024    |
| HP           | Horizontal polarity           |               |         |
| VT           | Vertical Total                |               | 806     |
| VW           | Vertical sync pulse width     |               | 6       |
| VS           | Vertical active start point   |               | 35      |
| VA           | Vertical active region        |               | 768     |
| VP           | Vertical polarity             |               |         |
| OCLK         | Output clock                  |               | 65      |
| Enable       |                               |               | off     |
| Save         | Click to save settings        |               | N/A     |



[Figure 13](#) and [Table 7](#) define the output Mode Setting:



Figure 13: Output Mode Setting Screen

Table 7: Output Mode Functions

| Setting       | Function   | Range         | Default |
|---------------|--|---------------|---------|
| Custom Output | Set custom values  | Custom 1 to 4 |         |
| HT            | Horizontal total   |               | 1344    |
| HW            | Horizontal sync pulse width  |               | 136     |
| HS            | Horizontal active start point  |               | 296     |
| HA            | Horizontal active region   |               | 1024    |
| HP            | Horizontal polarity  |               |         |
| VT            | Vertical total   |               | 806     |
| VW            | Vertical sync pulse width  |               | 6       |
| VS            | Vertical active start point  |               | 35      |
| VA            | Vertical active region   |               | 768     |
| VP            | Vertical polarity  |               |         |
| OCLK          | Output clock   |               | 65      |
| Save          | Click to save the settings   |               |         |
| Set Current   | Import the values of the currently selected output resolution into the User Mode Setting |               | N/A     |

### 9.1.2 The Transition Menu Items

[Figure 14](#) and [Table 8](#) define the Transition screen.

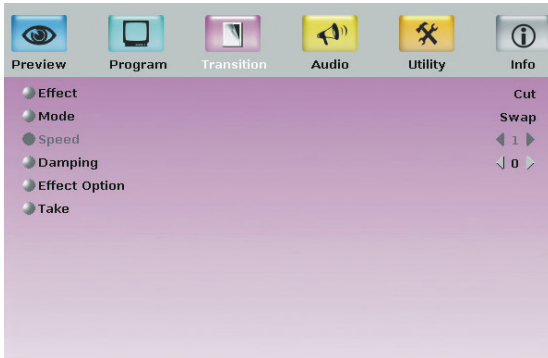

Figure 14: Transition Screen

Table 8: Transition Screen Functions

| Setting           | Function  | Selection/Range   | Default       |
|-------------------|---|---|---------------|
| Effect            | Set the transition effect   | Cut, Fade, Diagonal, Wipe, Circle, Square, Corner or Chessboard | Fade          |
| Mode              | Set the transition mode   | Swap or Follow  | Swap          |
| Speed             | Set the transition speed  | 1 to 5  | 3             |
| Damping           | Set the transition damping <sup>1</sup>                                 | 0 to 4  | 0             |
| Effect Option     | Diagonal:   |   | Top Left      |
|                   | Wipe:   |   | Left to Right |
|                   | Circle:   |   | Out           |
|                   | Square  |   | In            |
|                   | Corner  |   | Bottom Left   |
|                   | Chessboard  | <p>Each block performs as shown in the "Square" above</p>       | In            |
| Take <sup>1</sup> | Pressing causes the transition from preview to program (SWAP or FOLLOW) |   |               |

<sup>1</sup> When using the VP-747 together with the T-bar controller

### 9.1.3 The Audio Menu Items

The audio menu controls the **VP-727A** audio companion. See the **VP-727A** user manual for further detail<sup>2</sup>. [Figure 15](#) and [Table 9](#) define the screen.



Figure 15: Audio Screen

Table 9: Audio Screen Functions

| Setting     | Function   | Selection/Range                 | Default   |
|-------------|--|---------------------------------|-----------|
| Program     | Source   | Channel 1 to Channel 8          | Channel 1 |
|             | Input Volume   | -82 (mute) to +45               | 0         |
|             | Output Volume  | -22 (mute) to +9                | 0         |
|             | Delay <sup>3</sup>   | 0 to 127 [msec]                 | 0         |
| Preview     | Source   | Channel 1 to Channel 8          | Channel 1 |
|             | Input Volume   | -82 (mute) to +45               | 0         |
|             | Output Volume  | -82 (mute) to +45               | 0         |
| Headphones  | Set the headphone source   | Program or Preview              | Program   |
|             | Volume   | -12 (mute) to 4                 | 0         |
| Calibration | Bass   | -6 to 6                         | 0         |
|             | Treble   | -6 to 6                         | 0         |
|             | Balance  | -10 to 10                       | 0         |
| Option      | Audio-Follow-Video   | Follow or audio breakaway       | Follow    |
|             | Fade   | On or Off                       | On        |
|             | Mute-Follow  | Freeze, Blank or Freeze & Blank | none      |
| Take        | In the breakaway mode, preview and program audio inputs switch positions |                                 |           |

1 If the resolutions of Preview and Program are different, pressing the TAKE button when in the Freeze mode, will disable the Freeze mode

2 Download up-to-date Kramer user manuals from the Internet at this URL: <http://www.kramerelectronics.com>

3 Sets the pipeline delay of the audio (to compensate the delay in the video processing)

### 9.1.4 The Utility Menu Items

[Figure 16](#) and [Table 10](#) define the screen.



Figure 16: Utility Screen

Table 10: Utility Screen Functions

| Setting        | Function  | Selection/Range  | Default        |
|----------------|---|--|----------------|
| TCP/IP Setting | DHCP  | Off or On  | Off            |
|                | IP Address  |  | 192.168.1.39   |
|                | Subnet Mask                                       |  | 255.255.255.0  |
|                | Gateway   |  | 192.168.1.254  |
|                | Apply   | Apply settings   |                |
| OSD            | Menu Position                                     | Center, Top Left, Top Right, Bottom Left or Bottom Right | Center         |
|                | Time-Out  | 5, 10, 20, 30, 60, 90 seconds or Off                     | 30 Sec         |
| Misc. Settings | Logo  | Off or On  | On             |
|                | Save Lock (see <a href="#">Section 9.1.4.1</a> )  |  |                |
|                | Input Lock (see <a href="#">Section 9.1.4.2</a> ) | Off or On  | On             |
|                | Background  | Blue, Black or Disable Analog Sync                       | Black          |
|                | Blank Color                                       | Black or Blue  |                |
|                | Event Mode  | Off or On  | Off            |
|                | Baud Rate   | 9600 or 115200   | 115200         |
|                | Firmware Download                                 |  |                |
|                | HDCP Setting                                      | Follow Output or Follow Input                            |                |
|                | Auto Image  | Manual or Auto   | Manual         |
| Mode Set       | Mode 1  | 1400x1050@60Hz or 1680x1050@60Hz                         | 1680x1050x60Hz |
|                | Mode 2  | 1280x1024x75Hz or 1280x1024@76Hz                         | 1280x1024x75Hz |
|                | Mode 3  | 1280x768@60Hz or 1366x768@60Hz                           | 1280x768x60Hz  |
| Save           | Save profile <sup>1</sup>                         | From 1 to 8  |                |
| recall         | Recall profile <sup>1</sup>                       | From 1 to 8  |                |
| erase          | Erase profile <sup>1</sup>                        | From 1 to 8 or all                                       |                |
| Factory reset  |   |  |                |

<sup>1</sup> See [Section 9.1.4.1](#)

### 9.1.4.1 Save Lock

The Save Lock qualifies the Panel Lock<sup>1</sup>. When set to On, the status of the Panel lock is saved on power down, and then recalled when the unit is turned on again<sup>2</sup>.

### 9.1.4.2 Input Lock

The Input Lock qualifies the Panel Lock<sup>1</sup>. When set to On, the 8x2 Input buttons and the TAKE button are included in the buttons which are locked<sup>3</sup> when the Panel Lock is on.

### 9.1.4.3 Save/Recall/Eraser Setting Commands

You can save/recall/ up to 8 settings. In each setting you can preserve the entire machine's settings<sup>4</sup>. All parameters are saved/recalled, including the Universal Input configurations, ProcAmp settings, output resolutions, and so on. You can also erase a single setting or all of them.

### 9.1.5 The Information Menu Items

From the Info screen (see [Figure 17](#)), you can verify the program and preview source, video type and video standard as well as the PIP program and PIP Preview source, video type and video standard. The Info screen also displays the Preview and Program output resolutions.

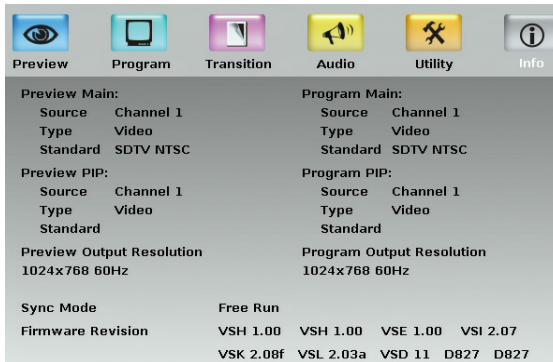

Figure 17: Info Screen

1 For a description of how to lock the front panel using the PANEL LOCK button, see [Section 8.5](#)

2 If the Save Lock is OFF, the Panel Lock will be OFF when the machine is powered up (even if the Panel Lock was ON before the power was turned OFF)

3 If the Input Lock is ON, access to the front panel buttons is blocked when Panel Lock is On, including the PROGRAM and PREVIEW INPUT selector front panel buttons, and the Program and Preview IR remote transmitter keys. When Input Lock is Off, then you can still access the 8x2 Input buttons and the TAKE button, even if the Panel Lock is On

4 This is useful, for example, for configuring the machine for multiple presentations. Up to 8 presentation configurations can be saved in the machine's memory

## 9.2 Operating via the Front Panel LCD Display

You can control the **VP-747** PREVIEW output from the front panel, high contrast, LCD Display, using the:

- Front panel OSD buttons: MENU, ENTER, ►, ◀, ▲, and ▼
- Infrared remote control transmitter (see [Figure 19](#)) keys: MENU, and the direction keys

For example, to set the time out to 60 seconds via the LCD Display, using the front panel buttons, do the following:

1. Turn the **VP-747** unit ON, and press the OSD ON button (if selected).
2. Press the appropriate front panel OSD buttons (as defined in [Figure 18](#)).

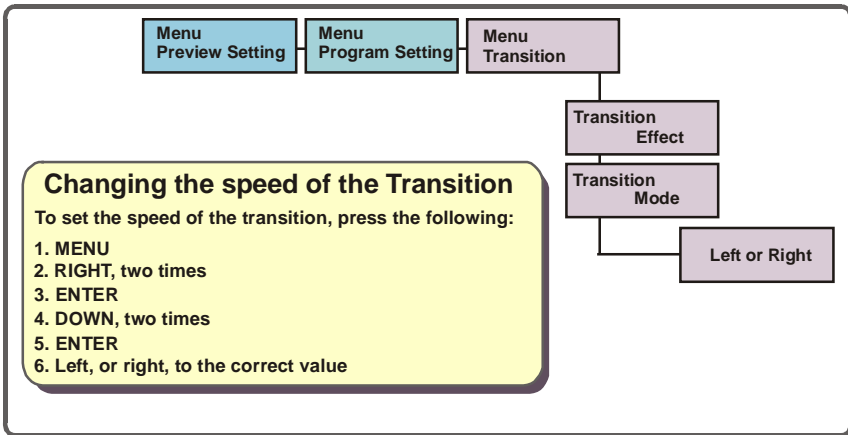

Figure 18: Example of how to use the LCD Display

### 9.3 Operating via the Infrared Remote Control Transmitter

You can control the **VP-747** remotely, from the infrared remote control transmitter (that has a range of up to 15 meters and is powered by two AAA size 1.5V DC batteries), as defined in [Figure 19](#) and [Table 11](#):

Figure 19: Remote Transmitter

Table 11: Remote Transmitter Functions

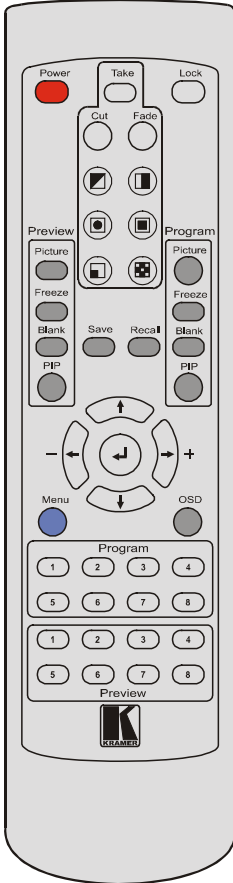

| Keys              | Function   |
|-------------------|--|
| Power             | Cycles power <sup>1</sup>  |
| Take <sup>2</sup> | Pressing TAKE causes the transition to occur   |
| Lock              | Locks/unlocks the front panel  |
| Cut <sup>3</sup>  | Selects an instantaneous transition from the PREVIEW output to the PROGRAM output  |
| Fade <sup>3</sup> | Selects a dissolved transition from the PREVIEW output to the PROGRAM output   |
|                   | Selects a <b>Diagonal</b> transition effect <sup>4,3</sup>   |
|                   | Selects a <b>WIPE</b> transition effect <sup>5,3</sup>   |
|                   | Selects a <b>CIRCLE</b> transition effect <sup>6,3</sup>   |
|                   | Selects a <b>SQUARE</b> transition effect <sup>6,3</sup>   |
|                   | Selects a <b>CORNER</b> transition effect <sup>4,3</sup>   |
|                   | Selects a <b>CHESSBOARD</b> transition effect <sup>6,3</sup>   |
| Picture           | Separate keys for PREVIEW/PROGRAM Outputs<br>Adjusts the picture contrast, brightness, saturation, auto gain, and auto image<br>Toggles the freeze function of the output video image<br>Toggles a blank screen<br>Toggles the picture-in-picture function |
| Freeze            |  |
| Blank             |  |
| PIP               |  |
| Save              | Saves the setting  |
| Recall            | Recalls the setting  |
| Navigation Keys   | Consists of a set of 5 separate keys that allow maneuvering within an OSD screen   |
| Menu              | Displays the OSD Menu screen (or moves to the previous level in the OSD menu)  |
| OSD               | Activates/deactivates access to the OSD Menu   |
| Selector          | 8 separate selector keys for both the Program and the Preview outputs  |

1 When “Off” the machine shuts down its outputs, disables the front panel, and causes the IR Receiver / LED to light red (instead of green)

2 The effect is only seen on the PROGRAM output

3 Only for setting up the unit for the effect. The effect will only occur when the Take button is pressed

4 Choose the direction from where the effect starts: “top left”, “bottom left”, “top right” or “bottom right” (see [Section 9.1.2](#))

5 Choose the direction from where the effect starts: “left to right”, “right to left”, “up” or “down” (see [Section 9.1.2](#))

6 Choose the direction from where the effect starts: “in” or “out” (see [Section 9.1.2](#))

## 9.4 Operating via the Ethernet

The control application lets you control the **VP-747** by clicking the desired buttons in the control application screen (which includes all the front panel buttons). To control the **VP-747** via the Ethernet/Serial Port:

1. Connect the Ethernet port (see [Section 7.4](#)) of the **VP-747** to the Ethernet port of your PC<sup>1</sup>.
2. Install and configure the Control Application (see [Section 9.4.1](#)).

### 9.4.1 Installing and Running the Configuration Software

To install the **VP-747** Control Application, do the following:

1. Insert the product CD into your CD-ROM drive<sup>2</sup>.
2. Save the zip file on your computer.
3. Run the installer setup.
4. Respond to the installation wizard prompts.

### 9.4.2 Configuring the Ethernet Connection

Double click the *VP747.exe* icon. The *VP747 Control Application* main screen appears (see [Figure 20](#)).

You can configure the Ethernet<sup>3</sup> in any one of the following ways; via

- The Ethernet connection, using the Lantronix device software<sup>2</sup>
- The **VP-747** Device menu (the OSD) or via the Control Application menu: <Utility> <TCP/IP setting>, and then setting the IP Address, subnet mask and so on, and then clicking Apply
- RS-232 communication between the PC and the **VP-747**, and setting the IP Address through the Com port menu in the Control Application

---

<sup>1</sup> Or connect the serial port of your VP-747 to the serial port of your PC (see [Section 7.1](#))

<sup>2</sup> You can download the software from our Web site on <http://www.kramerelectronics.com>

<sup>3</sup> The VP-747 communication port is 5000





Figure 20: VP-747 Control Application Screen

[Table 12](#) defines the menu items:

Table 12: VP-747 Control Application Menu

| Menu     | Items  |
|----------|--|
| File     | Save Configuration, Exit   |
| Com port | Select (the com port), Connect (to the selected com port)              |
| Ethernet | Connect to the Ethernet  |
| Menu     | Menu options (enter the VP-747 menu, see <a href="#">Section 9.1</a> ) |
| Help     | About  |

### 9.4.3 Control the VP-747 via the Ethernet/Serial Port

To control the **VP-747** via the Ethernet/serial port click the buttons on the virtual **VP-747** front panel and/or open the Menu item and use the OSD menus.

## 10 Technical Specifications

[Table 13](#) includes the technical specifications:

*Table 13: Technical Specifications<sup>1</sup> of the VP-747*

|                                   |   |
|-----------------------------------|---|
| INPUTS:                           | 2 HDMI/DVI inputs connectors (HDMI version 1.2 and HDCP version 1.2) on DVI connectors<br>8 sets of universal BNC connectors: R/Pr, G/Y/CV, B/Pb/C, Hs/Cs, and Vs, each programmable for use as CV, YC, RGB, YCbCr, YPbPr, RGSB or RGBHV  |
| PREVIEW OUTPUT:                   | 1 x HDMI/DVI input connector (HDMI version 1.2 and HDCP version 1.2) on a DVI connector<br>1 x VGA (VGA through UXGA) on a 15-pin HD connector<br>1 x RGBHV / YPbPr on BNC connectors   |
| PROGRAM OUTPUT:                   | 1 x HDMI/DVI input connector (HDMI version 1.2 and HDCP version 1.2) on a DVI connector<br>1 x VGA (VGA through UXGA) on a 15-pin HD connector<br>1 x RGBHV / YPbPr on BNC connectors   |
| OUTPUT RESOLUTIONS <sup>2</sup> : | 640x480 60Hz, 640x480 75Hz, 800x600 50Hz, 800x600 60Hz, 800x600 75Hz, 832x624 75Hz, 852x480 60Hz, 1024x768 50Hz, 1024x768 60Hz, 1024x768 75Hz, 1280x720 60Hz, 1280x768 50Hz, 1280x768 60Hz, 1280x800 60Hz, 1280x1024 50Hz, 1280x1024 60Hz, 1280x1024 75Hz, 1366x768 50Hz, 1366x768 60Hz, 1400x1050 50Hz, 1400x1050 60Hz, 1440x900 60Hz, 1600x1200 50Hz, 1600x1200 60Hz, 1680x1050 60Hz, 1920x1080 50Hz, 1920x1080 60Hz, 1920x1200 60Hz, 480p, 576p, 720p 50Hz, 720p 60Hz, 1080i 50Hz, 1080i 60Hz, 1080p 50Hz, 1080p 60Hz, 1080p 24Hz (for HDMI), or Custom <sup>3</sup> |
| CONTROLS:                         | Front panel buttons, high contrast LCD, IR remote control, ETHERNET, AUDIO CONTROL, RS-232 and RS-485 for optional T-bar remote controller  |
| ADDITIONAL CONTROLS:              | Freeze, zoom, different selectable vertical refresh rates, ProcAmp control, output image scaling, Picture-In-Picture, and aspect ratio change   |
| POWER SOURCE:                     | 100-240 VAC, 50/60Hz 65VA   |
| DIMENSIONS:                       | 19" (W), 9.3" (D), 3RU (H) rack mountable   |
| WEIGHT:                           | 5.5kg. (12.2lbs) approx.  |
| ACCESSORIES:                      | IR remote control, power cord, null-modem adapter   |
| OPTIONS:                          | Control panel   |

<sup>1</sup> Specifications are subject to change without notice

<sup>2</sup> For the most updated resolution list, go to our Web site at <http://www.kramerelectronics.com>

<sup>3</sup> Up to four custom settings

## 11 VP-747 Communication Protocol

This section includes the Communication Protocol for the **VP-747**:  
Communication Confirm:

```
Send CR
Reply CR>
```

Set Command

```
Send Y■Control_Type■Function■Param■CR
Reply Z■Control_Type■Function■Param■CR>
```

Get Command

```
Send Y■Control_Type■Function■CR
Reply Z■Control_Type■Function■Param■CR>
```

Example: set Preview Source Type of Current Channel = RGBHV

```
Send Y■0■43■0■CR
Reply Z■0■43■0■CR>
```

Example: get Preview Source Type of Current Channel

```
Send Y■1■43■CR
Reply Z■1■43■0■CR >
```

■: ASCII Code 0x20

CR : Ascii Code 0x0D

After set type Command setting, the system will respond with a string.

Baud rate: 9600/115200bps, Data Bit: 8Bit, Parity: None, and Stop Bit: 1Bit.

[Table 14](#) defines the Set Commands:

Table 14: Set Commands<sup>1</sup>

| Control Type |     | Function | Param1   | Param2 | Param3 | Param4 | Description  |
|--------------|-----|----------|--|--------|--------|--------|--|
| Set          | Get |          |  |        |        |        |  |
| 0            | 1   | 0        | 0:Off<br>1:On  | -      | -      | -      | Power  |
| 0            | 1   | 1        | 0:Off<br>1:On  | -      | -      | -      | Panel Lock   |
| 0            | -   | 2        | -  | -      | -      | -      | Take   |
| 0            | -   | 3        | -  | -      | -      | -      | Cut  |
| 0            | -   | 4        | -  | -      | -      | -      | Fade   |
| 0            | -   | 5        | -  | -      | -      | -      | Diagonal   |
| 0            | -   | 6        | -  | -      | -      | -      | Wipe   |
| 0            | -   | 7        | -  | -      | -      | -      | Circle   |
| 0            | -   | 8        | -  | -      | -      | -      | Square   |
| 0            | -   | 9        | -  | -      | -      | -      | Corner   |
| 0            | -   | 10       | -  | -      | -      | -      | Chessboard   |
| 0            | -   | 11       | -  | -      | -      | -      | Preview Picture  |
| 0            | 1   | 12       | 0:Off<br>1:On  | -      | -      | -      | Preview Freeze   |
| 0            | 1   | 13       | 0:Off<br>1:On  | -      | -      | -      | Preview Blank  |
| 0            | -   | 14       | -  | -      | -      | -      | Program Picture  |
| 0            | 1   | 15       | 0:Off<br>1:On  | -      | -      | -      | Program Freeze   |
| 0            | 1   | 16       | 0:Off<br>1:On  | -      | -      | -      | Program Blank  |
| 0            | -   | 17       | -  | -      | -      | -      | Up   |
| 0            | -   | 18       | -  | -      | -      | -      | Down   |
| 0            | -   | 19       | -  | -      | -      | -      | Left   |
| 0            | -   | 20       | -  | -      | -      | -      | Right  |
| 0            | -   | 21       | -  | -      | -      | -      | Menu   |
| 0            | -   | 22       | -  | -      | -      | -      | Enter  |
| 0            | 1   | 23       | 0: Off<br>1: On  | -      | -      | -      | OSD  |
| 0            | 1   | 41       | 0: Channel 1<br>1: Channel 2<br>2: Channel 3<br>3: Channel 4<br>4: Channel 5<br>5: Channel 6<br>6: Channel 7<br>7: Channel 8 | -      | -      | -      | Preview Input Source   |
| 0            | 1   | 42       | 0: RGBHV<br>1: RGBS(PC)<br>2: RGSB(PC)<br>3: RGBS(Video)<br>4: RGSB(Video)<br>5: YCbCr<br>6: Y/C<br>7: Video<br>8: HDMI      | -      | -      | -      | Preview Input Type<br>HDMI can only be selected for Channel 1 or Channel 2 |
| 0            | 1   | 43       | 0: Auto<br>1: NTSC<br>2: PAL<br>3: PAL-M<br>4: PAL-N<br>5: NTSC 4.43<br>6: SECAM<br>7: PAL 60                                | -      | -      | -      | Preview Input Video Standard   |

<sup>1</sup> F = Function

VP-747 Communication Protocol

| Control Type |     | Function | Param1   | Param2 | Param3 | Param4 | Description   |
|--------------|-----|----------|--|--------|--------|--------|---|
| Set          | Get |          |  |        |        |        |   |
| 0            | 1   | 44       | 1 ~ N  | -      | -      | -      | Preview Input Main Source H-Position<br>N: unfixed, will change with Input Mode             |
| 0            | 1   | 45       | 2 ~ N  | -      | -      | -      | Preview Input Main Source V-Position<br>N: unfixed, will change with Input Mode             |
| 0            | 1   | 46       | -A ~ A   | -      | -      | -      | Preview Input Frequency<br>A = (max - min)/2<br>min = 0 , max = will change with input mode |
| 0            | 1   | 47       | 0 ~ 31   | -      | -      | -      | Preview Input Phase (only for VGA Source)   |
| 0            | -   | 48       | -  | -      | -      | -      | Preview Auto Image  |
| 0            | 1   | 49       | 0: Off<br>1: On  | -      | -      | -      | Preview Over Scan Status  |
| 0            | 1   | 50       | -50 ~ 50   | -      | -      | -      | Preview Picture Brightness  |
| 0            | 1   | 51       | -50 ~ 50   | -      | -      | -      | Preview Picture Contrast  |
| 0            | 1   | 52       | -50 ~ 50   | -      | -      | -      | Preview Picture Color   |
| 0            | 1   | 53       | -180 ~ 180   | -      | -      | -      | Preview Picture Hue   |
| 0            | 1   | 54       | -50 ~ 50   | -      | -      | -      | Preview Picture Sharpness   |
| 0            | 1   | 55       | 0: Gamma 1<br>1: Gamma 2<br>2: Gamma 3<br>3: Gamma 4<br>4: Gamma 5 | -      | -      | -      | Preview Picture Output Gamma  |
| 0            | 1   | 56       | 0: Auto<br>1: Video<br>2: Film                                     | -      | -      | -      | Preview Picture Film Mode   |
| 0            | 1   | 57       | 0: Off<br>1: Low<br>2: Medium<br>3: High                           | -      | -      | -      | Preview Picture Temporal NR   |
| 0            | 1   | 58       | 0: Off<br>1: Low<br>2: Medium<br>3: High                           | -      | -      | -      | Preview Picture Mosquito NR   |
| 0            | 1   | 59       | 0: Off<br>1: On  | -      | -      | -      | Preview Picture Block NR  |
| 0            | 1   | 60       | 0: Off<br>1: Low<br>2: Medium<br>3: High                           | -      | -      | -      | Preview Picture Detail Enhancement  |
| 0            | 1   | 61       | 0: Off<br>1: Low<br>2: High  | -      | -      | -      | Preview Picture Luma Transition Enhance   |

VP-747 Communication Protocol

| Control Type |     | Function | Param1  | Param2 | Param3 | Param4 | Description                               |
|--------------|-----|----------|---|--------|--------|--------|---|
| Set          | Get |          |   |        |        |        |   |
| 0            | 1   | 62       | 0: Off<br>1: Low<br>2: High   | -      | -      | -      | Preview Picture Chroma Transition Enhance |
| 0            | 1   | 63       | 0: Best Fit<br>1: Letterbox<br>2: Follow Output<br>3: Virtual Wide<br>4: Follow Input<br>5: Custom                                  | -      | -      | -      | Preview Scale Aspect Ratio                |
| 0            | 1   | 64       | -16 ~ 16  | -      | -      | -      | Preview Scale H-Pan                       |
| 0            | 1   | 65       | -16 ~ 16  | -      | -      | -      | Preview Scale V-Pan                       |
| 0            | 1   | 66       | -8 ~ 8  | -      | -      | -      | Preview Scale H-Zoom                      |
| 0            | 1   | 67       | -8 ~ 8  | -      | -      | -      | Preview Scale V-Zoom                      |
| 0            | 1   | 68       | 0: Off<br>1: 150%<br>2: 200%<br>3: 225%<br>4: 250%<br>5: 275%<br>6: 300%<br>7: 325%<br>8: 350%<br>9: 375%<br>10: 400%<br>11: Custom | -      | -      | -      | Preview Scale Zoom                        |
| 0            | 1   | 69       | 0 ~ 32  | -      | -      | -      | Preview Scale Custom Zoom                 |
| 0            | 1   | 70       | -16 ~ 16  | -      | -      | -      | Preview Scale Zoom H-Pan                  |
| 0            | 1   | 71       | -16 ~ 16  | -      | -      | -      | Preview Scale Zoom V-Pan                  |
| 0            | 1   | 72       | 0: Off<br>1: On   | -      | -      | -      | Preview PIP On/Off                        |
| 0            | 1   | 73       | 0: Picture-In-Picture<br>1: Picture + Picture<br>2: Split   | -      | -      | -      | Preview PIP Type                          |
| 0            | 1   | 74       | 0: Channel 1<br>1: Channel 2<br>2: Channel 3<br>3: Channel 4<br>4: Channel 5<br>5: Channel 6<br>6: Channel 7<br>7: Channel 8        | -      | -      | -      | Preview PIP Source                        |
| 0            | 1   | 75       | 0: 1/25<br>1: 1/16<br>2: 1/9<br>3: 1/4<br>4: Custom   | -      | -      | -      | Preview PIP Size                          |
| 0            | 1   | 76       | 0 ~ 128   | -      | -      | -      | Preview PIP H-Position                    |
| 0            | 1   | 77       | 0 ~ 128   | -      | -      | -      | Preview PIP V-Position                    |
| 0            | 1   | 78       | 1 ~ 255   | -      | -      | -      | Preview PIP H-Size                        |
| 0            | 1   | 79       | 1 ~ 255   | -      | -      | -      | Preview PIP V-Size                        |
| 0            | 1   | 80       | 0: Off<br>1: On   | -      | -      | -      | Preview PIP Frame                         |



VP-747 Communication Protocol

| Control Type |     | Function | Param1   | Param2 | Param3 | Param4 | Description                              |
|--------------|-----|----------|--|--------|--------|--------|--|
| Set          | Get |          |  |        |        |        |  |
| 0            | 1   | 81       | 0:Red<br>1:Green<br>2:Blue   | -      | -      | -      | Preview PIP<br>Frame Color               |
| 0            | 1   | 82       | 0: 640x480 60Hz<br>1: 640x480 75Hz<br>2: 800x600 50Hz<br>3: 800x600 60Hz<br>4: 800x600 75Hz<br>5: 832x624 75Hz<br>6: 852x480 60Hz<br>7: 1024x768 50Hz<br>8: 1024x768 60Hz<br>9: 1024x768 75Hz<br>10: 1280x720 60Hz<br>11: 1280x768 50Hz<br>12: 1280x768 60Hz<br>13: 1280x800 60Hz<br>14: 1280x1024 50Hz<br>15: 1280x1024 60Hz<br>16: 1280x1024 75Hz<br>17: 1366x768 50Hz<br>18: 1366x768 60Hz<br>19: 1400x1050 50Hz<br>20: 1400x1050 60Hz<br>21: 1440x900 60Hz<br>22: 1600x1200 50Hz<br>23: 1600x1200 60Hz<br>24: 1680x1050 60Hz<br>25: 1920x1080 50Hz<br>26: 1920x1080 60Hz<br>27: 1920x1200 60Hz<br>28: 480p<br>29: 576p<br>30: 720p 50Hz<br>31: 720p 60Hz<br>32: 1080i 50Hz<br>33: 1080i 60Hz<br>34: 1080p 50Hz<br>35: 1080p 60Hz<br>36: 1080p 24Hz<br>37: Custom 1<br>38: Custom 2<br>39: Custom 3<br>40: Custom 4 | -      | -      | -      | Preview Output<br>Resolution             |
| 0            | 1   | 83       | -100 ~ 100   | -      | -      | -      | Preview Red<br>Saturation                |
| 0            | 1   | 84       | -100 ~ 100   | -      | -      | -      | Preview Green<br>Saturation              |
| 0            | 1   | 85       | -100 ~ 100   | -      | -      | -      | Preview Blue<br>Saturation               |
| 0            | 1   | 86       | -100 ~ 100   | -      | -      | -      | Preview Cyan<br>Saturation               |
| 0            | 1   | 87       | -100 ~ 100   | -      | -      | -      | Preview Magenta<br>Saturation            |
| 0            | 1   | 88       | -100 ~ 100   | -      | -      | -      | Preview Yellow<br>Saturation             |
| 0            | 1   | 89       | 0: Custom 1<br>1: Custom 2<br>2: Custom 3<br>3: Custom 4   | -      | -      | -      | Preview Custom<br>Input Target           |
| 0            | 1   | 90       | 512 ~ 3071   | -      | -      | -      | Preview Input<br>Setting User<br>Mode HT |

VP-747 Communication Protocol

| Control Type |     | Function | Param1   | Param2                  | Param3 | Param4 | Description                          |
|--------------|-----|----------|--|-------------------------|--------|--------|--------------------------------------|
| Set          | Get |          |  |                         |        |        |                                      |
| 0            | 1   | 91       | 32 ~ (HS-48)   | -                       | -      | -      | Preview Input Setting User Mode HW   |
| 0            | 1   | 92       | 80~(HT-HA-12)  | -                       | -      | -      | Preview Input Setting User Mode HS   |
| 0            | 1   | 93       | 640~1920<br><= (HT-92)                                   | -                       | -      | -      | Preview Input Setting User Mode HA   |
| 0            | 1   | 94       | 0: -<br>1: +   | -                       | -      | -      | Preview Input Setting User Mode HP   |
| 0            | 1   | 95       | 384~2047   | -                       | -      | -      | Preview Input Setting User Mode VT   |
| 0            | 1   | 96       | 2~(HS-13)  | -                       | -      | -      | Preview Input Setting User Mode VW   |
| 0            | 1   | 97       | 15~(VT-VA-1)   | -                       | -      | -      | Preview Input Setting User Mode VS   |
| 0            | 1   | 98       | 480~1200<br><= (VT-16)                                   | -                       | -      | -      | Preview Input Setting User Mode VA   |
| 0            | 1   | 99       | 0: -<br>1: +   | -                       | -      | -      | Preview Input Setting User Mode VP   |
| 0            | 1   | 100      | 25 ~ 165 (Integer Value)                                 | 0 ~ 999 (Decimal Value) | -      | -      | Preview Input Setting User Mode OCLK |
| 0            | 1   | 101      | 0:Off<br>1:On  | -                       | -      | -      | Preview Input Setting Enable         |
| 0            | -   | 102      | -  | -                       | -      | -      | Preview Input Setting User Mode Save |
| 0            | 1   | 103      | 0: Custom 1<br>1: Custom 2<br>2: Custom 3<br>3: Custom 4 | -                       | -      | -      | Preview Custom Output Target         |
| 0            | 1   | 104      | 512 ~ 3071   | -                       | -      | -      | Preview Output Setting User Mode HT  |
| 0            | 1   | 105      | 32 ~ (HS-48)   | -                       | -      | -      | Preview Output Setting User Mode HW  |
| 0            | 1   | 106      | 80~(HT-HA-12)  | -                       | -      | -      | Preview Output Setting User Mode HS  |
| 0            | 1   | 107      | 640 ~ 1920   | -                       | -      | -      | Preview Output Setting User Mode HA  |
| 0            | 1   | 108      | 0: -<br>1: +   | -                       | -      | -      | Preview Output Setting User Mode HP  |
| 0            | 1   | 109      | 384~2047   | -                       | -      | -      | Preview Output Setting User Mode VT  |
| 0            | 1   | 110      | 2~(HS-13)  | -                       | -      | -      | Preview Output Setting User Mode VW  |
| 0            | 1   | 111      | 15~(VT-VA-1)   | -                       | -      | -      | Preview Output Setting User Mode VS  |



VP-747 Communication Protocol

| Control Type |     | Function | Param1   | Param2                       | Param3       | Param4 | Description  |
|--------------|-----|----------|--|------------------------------|--------------|--------|--|
| Set          | Get |          |  |                              |              |        |  |
| 0            | 1   | 112      | 480 ~ 1200   | -                            | -            | -      | Preview Output Setting User Mode VA  |
| 0            | 1   | 113      | 0: -<br>1: +   | -                            | -            | -      | Preview Output Setting User Mode VP  |
| 0            | 1   | 114      | 25 ~ 165 (Integer Value)   | 0 ~ 999 (Decimal Value)      | -            | -      | Preview Output Setting User Mode OCLK                                      |
| 0            | -   | 115      | -  | -                            | -            | -      | Preview Output Setting User Mode Save                                      |
| 0            | -   | 116      | -  | -                            | -            | -      | Preview Output Setting User Mode Set Current                               |
| 0            | 1   | 117      | 0:Keystone<br>1:Anyplace<br>2:Rotation   | -                            | -            | -      | Preview Geometry Application   |
| 0            | 1   | 118      | 0: Front<br>1: Ceiling<br>2: Rear<br>3: Rear Ceiling   | -                            | -            | -      | Preview Geometry Location  |
| 0            | 1   | 119      | -40 ~ 40   | -                            | -            | -      | Preview Geometry H-Keystone  |
| 0            | 1   | 120      | -30 ~ 30   | -                            | -            | -      | Preview Geometry V-Keystone  |
| 0            | 1   | 121      | 0: Top Left<br>1: Top Right<br>2: Bottom Left<br>3: Bottom Right   | 0: Horizontal<br>1: vertical | -2000 ~ 2000 | -      | Preview Geometry Diagonal Projection                                       |
| 0            | -   | 122      | -  | -                            | -            | -      | Preview Geometry Diagonal Projection Reset                                 |
| 0            | 1   | 123      | -20 ~ 20   | -                            | -            | -      | Preview Geometry Pincushion/Barrel   |
| 0            | 1   | 124      | -180 ~ 180   | -                            | -            | -      | Preview Geometry Rotation  |
| 0            | -   | 125      | -  | -                            | -            | -      | Preview Geometry Reset all   |
| 0            | 1   | 151      | 0: Channel 1<br>1: Channel 2<br>2: Channel 3<br>3: Channel 4<br>4: Channel 5<br>5: Channel 6<br>6: Channel 7<br>7: Channel 8 | -                            | -            | -      | Program Input Source   |
| 0            | 1   | 152      | 0: RGBHV<br>1: RGBS(PC)<br>2: RGSB(PC)<br>3: RGBS(Video)<br>4: RGSB(Video)<br>5: YCbCr<br>6: Y/C<br>7: Video<br>8: HDMI      | -                            | -            | -      | Program Input Type<br>HDMI can only be selected for Channel 1 or Channel 2 |

VP-747 Communication Protocol

| Control Type |     | Function | Param1  | Param2 | Param3 | Param4 | Description   |
|--------------|-----|----------|---|--------|--------|--------|---|
| Set          | Get |          |   |        |        |        |   |
| 0            | 1   | 153      | 0: Auto<br>1: NTSC<br>2: PAL<br>3: PAL-M<br>4: PAL-N<br>5: NTSC 4.43<br>6: SECAM<br>7: PAL 60 | -      | -      | -      | Program Input Video Standard  |
| 0            | 1   | 154      | 1 ~ N   | -      | -      | -      | Program Input Main Source H-Position<br>N: unfixed, will change with Input Mode             |
| 0            | 1   | 155      | 2 ~ N   | -      | -      | -      | Program Input Main Source V-Position<br>N: unfixed, will change with Input Mode             |
| 0            | 1   | 156      | -A ~ A  | -      | -      | -      | Program Input Frequency<br>A = (max - min)/2<br>min = 0 , max = will change with input mode |
| 0            | 1   | 157      | 0 ~ 31  | -      | -      | -      | Program Input Phase (only for VGA Source)   |
| 0            | -   | 158      | -   | -      | -      | -      | Program Auto Image  |
| 0            | 1   | 159      | 0: Off<br>1: On   | -      | -      | -      | Program Over Scan Status  |
| 0            | 1   | 160      | -50 ~ 50  | -      | -      | -      | Program Picture Brightness  |
| 0            | 1   | 161      | -50 ~ 50  | -      | -      | -      | Program Picture Contrast  |
| 0            | 1   | 162      | -50 ~ 50  | -      | -      | -      | Program Picture Color   |
| 0            | 1   | 163      | -180 ~ 180  | -      | -      | -      | Program Picture Hue   |
| 0            | 1   | 164      | -50 ~ 50  | -      | -      | -      | Program Picture Sharpness   |
| 0            | 1   | 165      | 0: Gamma 1<br>1: Gamma 2<br>2: Gamma 3<br>3: Gamma 4<br>4: Gamma 5                            | -      | -      | -      | Program Picture Output Gamma  |
| 0            | 1   | 166      | 0: Auto<br>1: Video<br>2: Film  | -      | -      | -      | Program Picture Film Mode   |
| 0            | 1   | 167      | 0: Off<br>1: Low<br>2: Medium<br>3: High  | -      | -      | -      | Program Picture Temporal NR   |
| 0            | 1   | 168      | 0: Off<br>1: Low<br>2: Medium<br>3: High  | -      | -      | -      | Program Picture Mosquito NR   |
| 0            | 1   | 169      | 0: Off<br>1: On   | -      | -      | -      | Program Picture Block NR  |

VP-747 Communication Protocol

| Control Type |     | Function | Param1  | Param2 | Param3 | Param4 | Description                               |
|--------------|-----|----------|---|--------|--------|--------|---|
| Set          | Get |          |   |        |        |        |   |
| 0            | 1   | 170      | 0: Off<br>1: Low<br>2: Medium<br>3: High  | -      | -      | -      | Program Picture Detail Enhancement        |
| 0            | 1   | 171      | 0: Off<br>1: Low<br>2: High   | -      | -      | -      | Program Picture Luma Transition Enhance   |
| 0            | 1   | 172      | 0: Off<br>1: Low<br>2: High   | -      | -      | -      | Program Picture Chroma Transition Enhance |
| 0            | 1   | 173      | 0: Best Fit<br>1: Letterbox<br>2: Follow Output<br>3: Virtual Wide<br>4: Follow Input<br>5: Custom                                  | -      | -      | -      | Program Scale Aspect Ratio                |
| 0            | 1   | 174      | -16 ~ 16  | -      | -      | -      | Program Scale H-Pan                       |
| 0            | 1   | 175      | -16 ~ 16  | -      | -      | -      | Program Scale V-Pan                       |
| 0            | 1   | 176      | -8 ~ 8  | -      | -      | -      | Program Scale H-Zoom                      |
| 0            | 1   | 177      | -8 ~ 8  | -      | -      | -      | Program Scale V-Zoom                      |
| 0            | 1   | 178      | 0: Off<br>1: 150%<br>2: 200%<br>3: 225%<br>4: 250%<br>5: 275%<br>6: 300%<br>7: 325%<br>8: 350%<br>9: 375%<br>10: 400%<br>11: Custom | -      | -      | -      | Program Scale Zoom                        |
| 0            | 1   | 179      | 0 ~ 32  | -      | -      | -      | Program Scale Custom Zoom                 |
| 0            | 1   | 180      | -16 ~ 16  | -      | -      | -      | Program Scale Zoom H-Pan                  |
| 0            | 1   | 181      | -16 ~ 16  | -      | -      | -      | Program Scale Zoom V-Pan                  |
| 0            | 1   | 182      | 0: Off<br>1: On   | -      | -      | -      | Program PIP On/Off                        |
| 0            | 1   | 183      | 0: Picture-In-Picture<br>1: Picture + Picture<br>2: Split   | -      | -      | -      | Program PIP Type                          |
| 0            | 1   | 184      | 0: Channel 1<br>1: Channel 2<br>2: Channel 3<br>3: Channel 4<br>4: Channel 5<br>5: Channel 6<br>6: Channel 7<br>7: Channel 8        | -      | -      | -      | Program PIP Source                        |
| 0            | 1   | 185      | 0: 1/25<br>1: 1/16<br>2: 1/9<br>3: 1/4<br>4: Custom   | -      | -      | -      | Program PIP Size                          |
| 0            | 1   | 186      | 0 ~ 128   | -      | -      | -      | Program PIP H-Position                    |

VP-747 Communication Protocol

| Control Type |     | Function | Param1   | Param2 | Param3 | Param4 | Description                |
|--------------|-----|----------|--|--------|--------|--------|----------------------------|
| Set          | Get |          |  |        |        |        |                            |
| 0            | 1   | 187      | 0 ~ 128  | -      | -      | -      | Program PIP V-Position     |
| 0            | 1   | 188      | 1 ~ 255  | -      | -      | -      | Program PIP H-Size         |
| 0            | 1   | 189      | 1 ~ 255  | -      | -      | -      | Program PIP V-Size         |
| 0            | 1   | 200      | 0: Off<br>1: On  | -      | -      | -      | Program PIP Frame          |
| 0            | 1   | 201      | 0:Red<br>1:Green<br>2:Blue   | -      | -      | -      | Program PIP Frame Color    |
| 0            | 1   | 202      | 0: 640x480 60Hz<br>1: 640x480 75Hz<br>2: 800x600 50Hz<br>3: 800x600 60Hz<br>4: 800x600 75Hz<br>5: 832x624 75Hz<br>6: 852x480 60Hz<br>7: 1024x768 50Hz<br>8: 1024x768 60Hz<br>9: 1024x768 75Hz<br>10: 1280x720 60Hz<br>11: 1280x768 50Hz<br>12: 1280x768 60Hz<br>13: 1280x800 60Hz<br>14: 1280x1024 50Hz<br>15: 1280x1024 60Hz<br>16: 1280x1024 75Hz<br>17: 1366x768 50Hz<br>18: 1366x768 60Hz<br>19: 1400x1050 50Hz<br>20: 1400x1050 60Hz<br>21: 1440x900 60Hz<br>22: 1600x1200 50Hz<br>23: 1600x1200 60Hz<br>24: 1680x1050 60Hz<br>25: 1920x1080 50Hz<br>26: 1920x1080 60Hz<br>27: 1920x1200 60Hz<br>28: 480p<br>29: 576p<br>30: 720p 50Hz<br>31: 720p 60Hz<br>32: 1080i 50Hz<br>33: 1080i 60Hz<br>34: 1080p 50Hz<br>35: 1080p 60Hz<br>36: 1080p 24Hz<br>37: Custom 1<br>38: Custom 2<br>39: Custom 3<br>40: Custom 4 | -      | -      | -      | Program Output Resolution  |
| 0            | 1   | 203      | -100 ~ 100   | -      | -      | -      | Program Red Saturation     |
| 0            | 1   | 204      | -100 ~ 100   | -      | -      | -      | Program Green Saturation   |
| 0            | 1   | 205      | -100 ~ 100   | -      | -      | -      | Program Blue Saturation    |
| 0            | 1   | 206      | -100 ~ 100   | -      | -      | -      | Program Cyan Saturation    |
| 0            | 1   | 207      | -100 ~ 100   | -      | -      | -      | Program Magenta Saturation |

VP-747 Communication Protocol

| Control Type |     | Function | Param1   | Param2                  | Param3 | Param4 | Description                          |
|--------------|-----|----------|--|-------------------------|--------|--------|--------------------------------------|
| Set          | Get |          |  |                         |        |        |                                      |
| 0            | 1   | 208      | -100 ~ 100   | -                       | -      | -      | Program Yellow Saturation            |
| 0            | 1   | 209      | 0: Custom 1<br>1: Custom 2<br>2: Custom 3<br>3: Custom 4 | -                       | -      | -      | Program Custom Input Target          |
| 0            | 1   | 210      | 512~3071   | -                       | -      | -      | Program Input Setting User Mode HT   |
| 0            | 1   | 211      | 32~(HS-48)   | -                       | -      | -      | Program Input Setting User Mode HW   |
| 0            | 1   | 212      | 80~(HT-HA-12)  | -                       | -      | -      | Program Input Setting User Mode HS   |
| 0            | 1   | 213      | 640~1920<br><= (HT-92)                                   | -                       | -      | -      | Program Input Setting User Mode HA   |
| 0            | 1   | 214      | 0: -<br>1: +   | -                       | -      | -      | Program Input Setting User Mode HP   |
| 0            | 1   | 215      | 384~2047   | -                       | -      | -      | Program Input Setting User Mode VT   |
| 0            | 1   | 216      | 2~(HS-13)  | -                       | -      | -      | Program Input Setting User Mode VW   |
| 0            | 1   | 217      | 15~(VT-VA-1)   | -                       | -      | -      | Program Input Setting User Mode VS   |
| 0            | 1   | 218      | 480~1200<br><= (VT-16)                                   | -                       | -      | -      | Program Input Setting User Mode VA   |
| 0            | 1   | 219      | 0: -<br>1: +   | -                       | -      | -      | Program Input Setting User Mode VP   |
| 0            | 1   | 220      | 25 ~ 165 (Integer Value)                                 | 0 ~ 999 (Decimal Value) | -      | -      | Program Input Setting User Mode OCLK |
| 0            | 1   | 221      | 0: Off<br>1: On  | -                       | -      | -      | Program Input Setting Enable         |
| 0            | -   | 222      | -  | -                       | -      | -      | Program Input Setting User Mode Save |
| 0            | 1   | 223      | 0: Custom 1<br>1: Custom 2<br>2: Custom 3<br>3: Custom 4 | -                       | -      | -      | Program Custom Output Target         |
| 0            | 1   | 224      | 512~3071   | -                       | -      | -      | Program Output Setting User Mode HT  |
| 0            | 1   | 225      | 32~(HS-48)   | -                       | -      | -      | Program Output Setting User Mode HW  |
| 0            | 1   | 226      | 80~(HT-HA-12)  | -                       | -      | -      | Program Output Setting User Mode HS  |
| 0            | 1   | 227      | 640~1920<br><= (HT-92)                                   | -                       | -      | -      | Program Output Setting User Mode HA  |
| 0            | 1   | 228      | 0: -<br>1: +   | -                       | -      | -      | Program Output Setting User Mode HP  |

VP-747 Communication Protocol

| Control Type |     | Function | Param1  | Param2                     | Param3       | Param4 | Description                                  |
|--------------|-----|----------|---|----------------------------|--------------|--------|--|
| Set          | Get |          |   |                            |              |        |  |
| 0            | 1   | 229      | 384-2047  | -                          | -            | -      | Program Output Setting User Mode VT          |
| 0            | 1   | 230      | 2-(HS-13)   | -                          | -            | -      | Program Output Setting User Mode VW          |
| 0            | 1   | 231      | 15-(VT-VA-1)  | -                          | -            | -      | Program Output Setting User Mode VS          |
| 0            | 1   | 232      | 480-1200<br><= (VT-16)  | -                          | -            | -      | Program Output Setting User Mode VA          |
| 0            | 1   | 233      | 0: -<br>1: +  | -                          | -            | -      | Program Output Setting User Mode VP          |
| 0            | 1   | 234      | 25 ~ 165 (Integer Value)  | 0 ~ 999<br>(Decimal Value) | -            | -      | Program Output Setting User Mode OCLK        |
| 0            | -   | 235      | -   | -                          | -            | -      | Program Output Setting User Mode Save        |
| 0            | -   | 236      | -   | -                          | -            | -      | Program Output Setting User Mode Set Current |
| 0            | 1   | 237      | 0:Keystone<br>1:Anyplace<br>2:Rotation  |                            |              |        | Program Geometry Application                 |
| 0            | 1   | 238      | 0: Front<br>1: Ceiling<br>2: Rear<br>3: Rear Ceiling  |                            |              |        | Program Geometry Location                    |
| 0            | 1   | 239      | -40 ~ 40  |                            |              |        | Program Geometry H-Keystone                  |
| 0            | 1   | 240      | -30 ~ 30  |                            |              |        | Program Geometry V-Keystone                  |
| 0            | 1   | 241      | 0: Top Left<br>1: Top Right<br>2: Bottom Left<br>3: Bottom Right                                    | 0:H<br>1:V                 | -2000 ~ 2000 |        | Program Geometry Diagonal Projection         |
| 0            | -   | 242      | -   |                            |              |        | Program Geometry Diagonal Projection Reset   |
| 0            | 1   | 243      | -20 ~ 20  |                            |              |        | Program Geometry Pincushion/Barrel           |
| 0            | 1   | 244      | -180 ~ 180  |                            |              |        | Program Geometry Rotation                    |
| 0            | -   | 245      | -   |                            |              |        | Program Geometry Reset all                   |
| 0            | 1   | 271      | 0: Cut<br>1: Fade<br>2: Diagonal<br>3: Wipe<br>4: Circle<br>5: Square<br>6: Corner<br>7: Chessboard |                            |              |        | Transition Effect                            |

VP-747 Communication Protocol

| Control Type |     | Function | Param1  | Param2 | Param3 | Param4 | Description                             |
|--------------|-----|----------|---|--------|--------|--------|---|
| Set          | Get |          |   |        |        |        |   |
| 0            | 1   | 272      | 0:Swap<br>1:Follow  | -      | -      | -      | Transition Mode                         |
| 0            | 1   | 273      | 1 ~ 5   | -      | -      | -      | Transition Speed                        |
| 0            | 1   | 274      | 0 = no damping<br>1 = damping with a maximum jump size of 10 steps<br>2 = damping with a maximum jump size of 5 steps<br>3 = damping with a maximum jump size of 3 steps<br>4 = damping with a maximum jump size of 2 steps | -      | -      | -      | Transition Damping                      |
| 0            | 1   | 275      | 0: Top left<br>1: Bottom left<br>2: Top right<br>3: Bottom right  | -      | -      | -      | Transition Effect Option - Diagonal     |
| 0            | 1   | 276      | 0: Left to right<br>1: Right to left<br>2: Up<br>3: Down  | -      | -      | -      | Transition Effect Option - Wipe         |
| 0            | 1   | 277      | 0: In<br>1: Out   | -      | -      | -      | Transition Effect Option - Circle       |
| 0            | 1   | 278      | 0: In<br>1: Out   | -      | -      | -      | Transition Effect Option - Square       |
| 0            | 1   | 279      | 0: Top left<br>1: Bottom left<br>2: Top right<br>3: Bottom right  | -      | -      | -      | Transition Effect Option - Corner       |
| 0            | 1   | 280      | 0: In<br>1: Out   | -      | -      | -      | Transition Effect Option - Chessboard   |
| 0            | -   | 281      | -   | -      | -      | -      | Transition Take                         |
| 0            | 1   | 286      | 0: Channel 1<br>1: Channel 2<br>2: Channel 3<br>3: Channel 4<br>4: Channel 5<br>5: Channel 6<br>6: Channel 7<br>7: Channel 8  | -      | -      | -      | Audio Program input source              |
| 0            | 1   | 287      | -82 ~ 45  | -      | -      | -      | Audio Program Input Volume, -82 = Mute  |
| 0            | 1   | 288      | -22 ~ 9   | -      | -      | -      | Audio Program Output Volume, -22 = Mute |
| 0            | 1   | 289      | 0 ~ 127   | -      | -      | -      | Audio Program Input Delay               |
| 0            | 1   | 290      | 0: Channel 1<br>1: Channel 2<br>2: Channel 3<br>3: Channel 4<br>4: Channel 5<br>5: Channel 6<br>6: Channel 7<br>7: Channel 8  | -      | -      | -      | Audio Preview input source              |
| 0            | 1   | 291      | -82 ~ 45  | -      | -      | -      | Audio Preview Input Volume, -82 = Mute  |
| 0            | 1   | 292      | -82 ~ 45  | -      | -      | -      | Audio Preview Output Volume, -82 = Mute |

VP-747 Communication Protocol

| Control Type |     | Function | Param1   | Param2  | Param3   | Param4  | Description                                 |
|--------------|-----|----------|--|---|--|---------|---|
| Set          | Get |          |  |   |  |         |   |
| 0            | 1   | 293      | 0: Preview<br>1: Program   | -   | -  | -       | Audio<br>headphone<br>source                |
| 0            | 1   | 294      | -12 ~ 4  | -   | -  | -       | Audio<br>Headphone<br>Volume, -12 =<br>Mute |
| 0            | 1   | 295      | -6 ~ 6   | -   | -  | -       | Audio Bass                                  |
| 0            | 1   | 296      | -6 ~ 6   | -   | -  | -       | Audio Treble0                               |
| 0            | 1   | 297      | -10 ~ 10   | -   | -  | -       | Audio Balance                               |
| -            | 1   | 298      | 0~32767<br>1->ON, 0->OFF<br>bit 0: Chessboard<br>bit 1: Panel lock<br>bit 2: Menu<br>bit 3: Enter<br>bit 4: Left<br>bit 5: Up<br>bit 6: Down<br>bit 7: Right<br>bit 8: OSD | 0~32767<br>1->ON, 0->OFF<br>bit 0: Program<br>Channel 8<br>bit 1: Preview<br>Freeze<br>bit 2: Program<br>Freeze<br>bit 3: Preview<br>Blank<br>bit 4: Program<br>Blank<br>bit 5: Preview<br>PIP<br>bit 6: Program<br>PIP<br>bit 7: Take<br>bit 8: Cut<br>bit 9: Diagonal<br>bit 10: Circle<br>bit 11: Corner<br>bit 12: Fade<br>bit 13: Wipe<br>bit 14: Square | 0~32767<br>1-> ON, 0->OFF<br>bit 0: Preview Channel 1<br>bit 1: Program Channel 1<br>bit 2: Preview Channel 2<br>bit 3: Program Channel 2<br>bit 4: Preview Channel 3<br>bit 5: Program Channel 3<br>bit 6: Preview Channel 4<br>bit 7: Program Channel 4<br>bit 8: Preview Channel 5<br>bit 9: Program Channel 5<br>bit 10: Preview Channel 6<br>bit 11: Program Channel 6<br>bit 12: Preview Channel 7<br>bit 13: Program Channel 7<br>bit 14: Preview Channel 8 | -       | Keypad LED<br>status                        |
| 0            | 1   | 299      | 0: Audio Folow Video<br>1: Audio Breakaway   | -   | -  | -       | Audio Follow<br>Video or Audio<br>Breakaway |
| 0            | 1   | 300      | 0: Off<br>1: On  | -   | -  | -       | Audio Fade                                  |
| 0            | 1   | 301      | 0:None<br>1:Freeze<br>2:Blank<br>3:Freeze&Blank  | -   | -  | -       | Audio Mute-<br>Follow                       |
| 0            | -   | 302      | -  | -   | -  | -       | Audio TAKE                                  |
| 0            | 1   | 306      | 0: Off<br>1: On  | -   | -  | -       | TCPIP DHCP                                  |
| 0            | 1   | 307      | 0 ~ 255  | 0 ~ 255   | 0 ~ 255  | 0 ~ 255 | TCPIP IP<br>Address                         |
| 0            | 1   | 308      | 0 ~ 255  | 0 ~ 255   | 0 ~ 255  | 0 ~ 255 | TCPIP Subnet<br>Mask                        |
| 0            | 1   | 309      | 0 ~ 255  | 0 ~ 255   | 0 ~ 255  | 0 ~ 255 | TCPIP Gateway                               |
| 0            | -   | 310      | -  | -   | -  | -       | TCPIP Apply                                 |
| 0            | 1   | 311      | 0: Center<br>1: Top Left<br>2: Top Right<br>3: Bottom Left<br>4: Bottom Right  | -   | -  | -       | OSD Setting<br>Menu Position                |
| 0            | 1   | 312      | 0: 5 second<br>1: 10 second<br>2: 20 second<br>3: 30 second<br>4: 60 second<br>5: 90 second<br>6: off  | -   | -  | -       | OSD Setting<br>TimeOut                      |





VP-747 Communication Protocol

| Control Type |     | Function | Param1   | Param2 | Param3 | Param4 | Description               |
|--------------|-----|----------|--|--------|--------|--------|---------------------------|
| Set          | Get |          |  |        |        |        |                           |
| 0            | 1   | 313      | 0: Off<br>1: On (Kramer)   | -      | -      | -      | Misc Setting Logo         |
| 0            | 1   | 314      | 0: Off<br>1: On  | -      | -      | -      | Misc Setting Save Lock    |
| 0            | 1   | 315      | 0: Off<br>1: On  | -      | -      | -      | Misc Setting Input Lock   |
| 0            | 1   | 316      | 0:Blank<br>1:Blue<br>2:Disable Analog Sync   | -      | -      | -      | Misc Setting Background   |
| 0            | 1   | 317      | 0: Black<br>1: Blue  | -      | -      | -      | Misc Setting Blank Color  |
| 0            | 1   | 318      | 0:Off<br>1:On  | -      | -      | -      | Misc Setting Event Mode   |
| 0            | 1   | 319      | 0:9600<br>1:115200   | -      | -      | -      | Misc Setting Baudrate     |
| 0            | 1   | 320      | 0: Follow Output<br>1: Follow Input  | -      | -      | -      | Misc Setting HDCP Setting |
| 0            | -   | 321      | 0: Profile 1<br>1: Profile 2<br>2: Profile 3<br>3: Profile 4<br>4: Profile 5<br>5: Profile 6<br>6: Profile 7<br>7: Profile 8           | -      | -      | -      | Save                      |
| 0            | -   | 322      | 0: Profile 1<br>1: Profile 2<br>2: Profile 3<br>3: Profile 4<br>4: Profile 5<br>5: Profile 6<br>6: Profile 7<br>7: Profile 8           | -      | -      | -      | Recall                    |
| 0            | -   | 323      | 0: Profile 1<br>1: Profile 2<br>2: Profile 3<br>3: Profile 4<br>4: Profile 5<br>5: Profile 6<br>6: Profile 7<br>7: Profile 8<br>8: All | -      | -      | -      | Erase                     |
| 0            | -   | 324      | -  | -      | -      | -      | Factory Reset             |
| 0            | 1   | 325      | 0:Mode1<br>1400x1050@60HZ<br>1:Mode1<br>1680x1050@60HZ   | -      | -      | -      | Mode Set Mode1            |
| 0            | 1   | 326      | 0:Mode2<br>1280x1024@75HZ<br>1:Mode2<br>1280x1024@76HZ   | -      | -      | -      | Mode Set Mode2            |
| 0            | 1   | 327      | 0:Mode3<br>1280x768@60HZ<br>1:Mode3<br>1366x768@60HZ   | -      | -      | -      | Mode Set Mode3            |
| 0            | 1   | 328      | 0:Manual (Default)<br>1:Auto   | -      | -      | -      | Auto Image Mode           |

---

## LIMITED WARRANTY

Kramer Electronics (hereafter *Kramer*) warrants this product free from defects in material and workmanship under the following terms.

### HOW LONG IS THE WARRANTY

Labor and parts are warranted for seven years from the date of the first customer purchase.

### WHO IS PROTECTED?

Only the first purchase customer may enforce this warranty.

### WHAT IS COVERED AND WHAT IS NOT COVERED

Except as below, this warranty covers all defects in material or workmanship in this product. The following are not covered by the warranty:

1. Any product which is not distributed by Kramer, or which is not purchased from an authorized Kramer dealer. If you are uncertain as to whether a dealer is authorized, please contact Kramer at one of the agents listed in the Web site [www.kramerelectronics.com](http://www.kramerelectronics.com).
2. Any product, on which the serial number has been defaced, modified or removed, or on which the WARRANTY VOID IF TAMPERED sticker has been torn, reattached, removed or otherwise interfered with.
3. Damage, deterioration or malfunction resulting from:
  - i) Accident, misuse, abuse, neglect, fire, water, lightning or other acts of nature
  - ii) Product modification, or failure to follow instructions supplied with the product
  - iii) Repair or attempted repair by anyone not authorized by Kramer
  - iv) Any shipment of the product (claims must be presented to the carrier)
  - v) Removal or installation of the product
  - vi) Any other cause, which does not relate to a product defect
  - vii) Cartons, equipment enclosures, cables or accessories used in conjunction with the product

### WHAT WE WILL PAY FOR AND WHAT WE WILL NOT PAY FOR

We will pay labor and material expenses for covered items. We will not pay for the following:

1. Removal or installations charges.
2. Costs of initial technical adjustments (set-up), including adjustment of user controls or programming. These costs are the responsibility of the Kramer dealer from whom the product was purchased.
3. Shipping charges.

### HOW YOU CAN GET WARRANTY SERVICE

1. To obtain service on you product, you must take or ship it prepaid to any authorized Kramer service center.
2. Whenever warranty service is required, the original dated invoice (or a copy) must be presented as proof of warranty coverage, and should be included in any shipment of the product. Please also include in any mailing a contact name, company, address, and a description of the problem(s).
3. For the name of the nearest Kramer authorized service center, consult your authorized dealer.

### LIMITATION OF IMPLIED WARRANTIES

All implied warranties, including warranties of merchantability and fitness for a particular purpose, are limited in duration to the length of this warranty.

### EXCLUSION OF DAMAGES

The liability of Kramer for any effective products is limited to the repair or replacement of the product at our option. Kramer shall not be liable for:

1. Damage to other property caused by defects in this product, damages based upon inconvenience, loss of use of the product, loss of time, commercial loss; or:
2. Any other damages, whether incidental, consequential or otherwise. Some countries may not allow limitations on how long an implied warranty lasts and/or do not allow the exclusion or limitation of incidental or consequential damages, so the above limitations and exclusions may not apply to you.

This warranty gives you specific legal rights, and you may also have other rights, which vary from place to place.

**NOTE:** All products returned to Kramer for service must have prior approval. This may be obtained from your dealer.

This equipment has been tested to determine compliance with the requirements of:

- EN-50081: "Electromagnetic compatibility (EMC);  
generic emission standard.  
Part 1: Residential, commercial and light industry"
- EN-50082: "Electromagnetic compatibility (EMC) generic immunity standard.  
Part 1: Residential, commercial and light industry environment".
- CFR-47: FCC\* Rules and Regulations:  
Part 15: "Radio frequency devices  
Subpart B Unintentional radiators"

### CAUTION!

- Servicing the machines can only be done by an authorized Kramer technician. Any user who makes changes or modifications to the unit without the expressed approval of the manufacturer will void user authority to operate the equipment.
- Use the supplied DC power supply to feed power to the machine.
- Please use recommended interconnection cables to connect the machine to other components.  
\* FCC and CE approved using STP cable (for twisted pair products)





---

**For the latest information on our products and a list of Kramer distributors, visit our Web site: [www.kramerelectronics.com](http://www.kramerelectronics.com), where updates to this user manual may be found. We welcome your questions, comments and feedback.**



**Caution**

**Safety Warning:**

Disconnect the unit from the power supply before opening/servicing.



---

**Kramer Electronics, Ltd.**

Web site: [www.kramerelectronics.com](http://www.kramerelectronics.com)

E-mail: [info@kramereel.com](mailto:info@kramereel.com)

P/N: 2900-000563 REV 1