



GRUNTAVORE LIFT

Item # 16867

INSTRUCTIONS - PARTS DRAWING - PARTS LIST

WARNING: READ INSTRUCTIONS BEFORE OPERATING

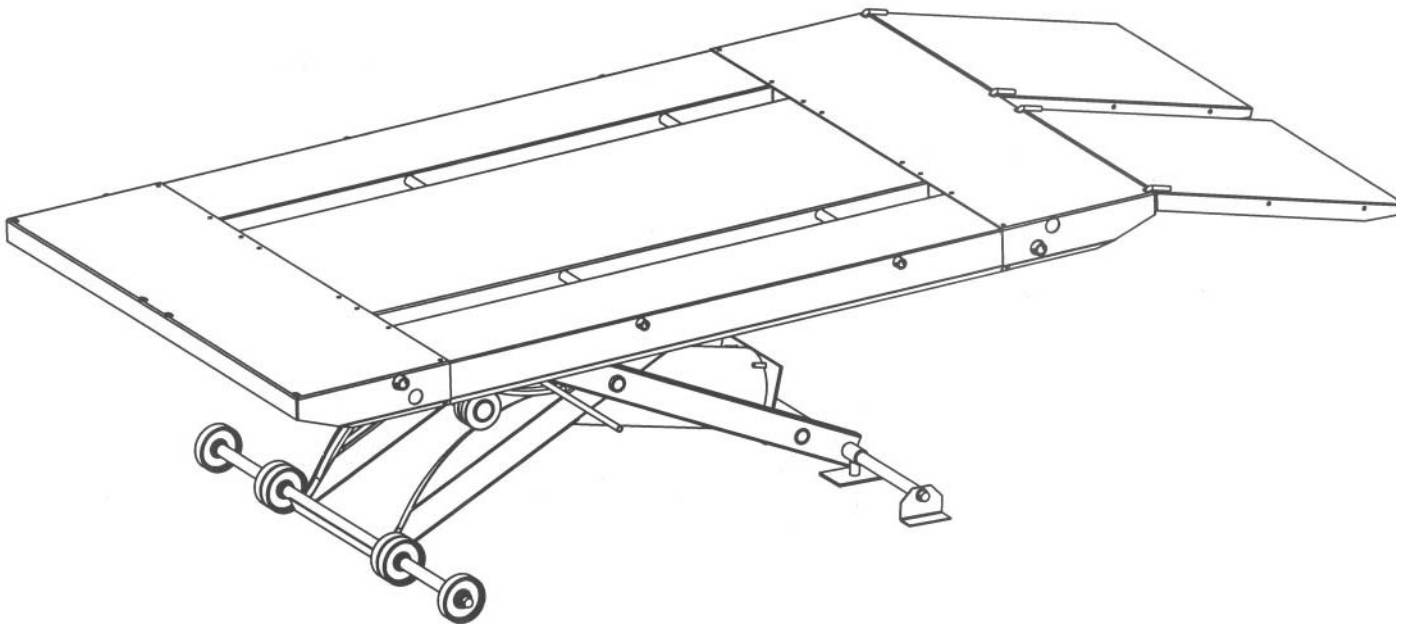

1. Center load on table - 1800 lb. maximum.
2. Connect to 100 psi maximum shop air.
3. Keep safety bar in position at all times - except when lowering.
4. Keep hands and tools from under carriage.
5. Do not mount table when in elevated position.
6. Do not ride vehicle onto lift.
7. Lift must be in the lowered position when moving.
8. Only trained persons should operate Air Lift.
9. The working area should be sufficiently lit.
10. Foot controller should be at least 3 feet away from Air Lift during raising and lowering operation.

HANDY INDUSTRIES L.L.C.

702 South 3rd Ave. Marshalltown, IA 50158 1-800-247-7594 Fax 641-752-1205 www.handyindustries.com



GRUNTAVORE LIFT



NOTE: READ ENTIRE MANUAL TO COMPLY WITH ALL SAFETY AND SERVICE PRECAUTIONS. DEATH, PERSONAL INJURY AND/OR PROPERTY DAMAGE MAY OCCUR UNLESS INSTRUCTIONS ARE FOLLOWED CAREFULLY.

INSTRUCTIONS

UNPACKING AND SET-UP

1. Open carton, then remove ramp and shipping boards.
2. Connect foot-operated air valve to 100 psi maximum air supply. The lift may be damaged and/or personal injury may result if the pressure exceeds the maximum 100 psi rating.
3. Stand clear of lift table, and depress the UP side of foot valve to raise table.
4. To lower table, lift detent bar from safety latch and lower to next position or to floor.
5. To mount ramp, insert ramp mounting pins into holes at end of table opposite vise holes.

UNPACKING AND SET-UP OF EXTENSION COMPONENTS

1. Open cartons containing side and end extension components. Refer to the illustration and parts list page.
2. Connect Air Lift to 100 psi air then raise lift and engage safety detent bar.
3. Insert the 53-1/4" stabilizer shafts thru each frame end. Place axle extensions with the wheels secured by two spiral retaining rings onto shaft then retain with quick pins. Place stabilizer feet onto shaft at outside frame and retain with quick pins.
4. Insert the two 3/4" pipes thru holes near center of lift top. Place side extensions onto these pipes and retain with quick pins at each end of the pipe.
5. Pull side extensions out against quick pins and center side extensions on the Air Lift.
6. Place end extension onto lift top and side extensions aligning pipe holes, then insert 1" pipe. Install quick pins at pipe ends. Secure end extensions to both lift top and side extensions to both lift top and side extension using ten 5/16-18 cap screws and nuts for each end extension. Note eight bolts go down and one is located at each side near bend.
7. Attach detent handle extensions on each side of detent safety bar. See detail on illustration and parts list page.
8. To mount ramps, insert mounting pins in to matching slots on the end extension farthest from the wheels of the Air Lift.

OPERATION

1. Loads must be centered on table at all times. Table is rated for a maximum load of 1800 lbs.
2. Loads must be firmly positioned and secured on table at all times.
3. All moving parts have been lubricated at the factory and should be re-lubricated every (6) months to prevent galling. Grease zerks are located at each end of frame pivot shaft and at top ends of inside frame assembly.
4. Lightly oil cylinder rod when it becomes dry.
5. Squirt some oil through bleed hole in plate end of cylinder to lubricate piston and its seal every (6) months.
6. Pivot shaft set screws should be checked frequently to be sure they are tight. These are located at the top end of the inside frame assembly.



GRUNTAVORE LIFT

MOUNTING ILLUSTRATION AND PARTS LIST

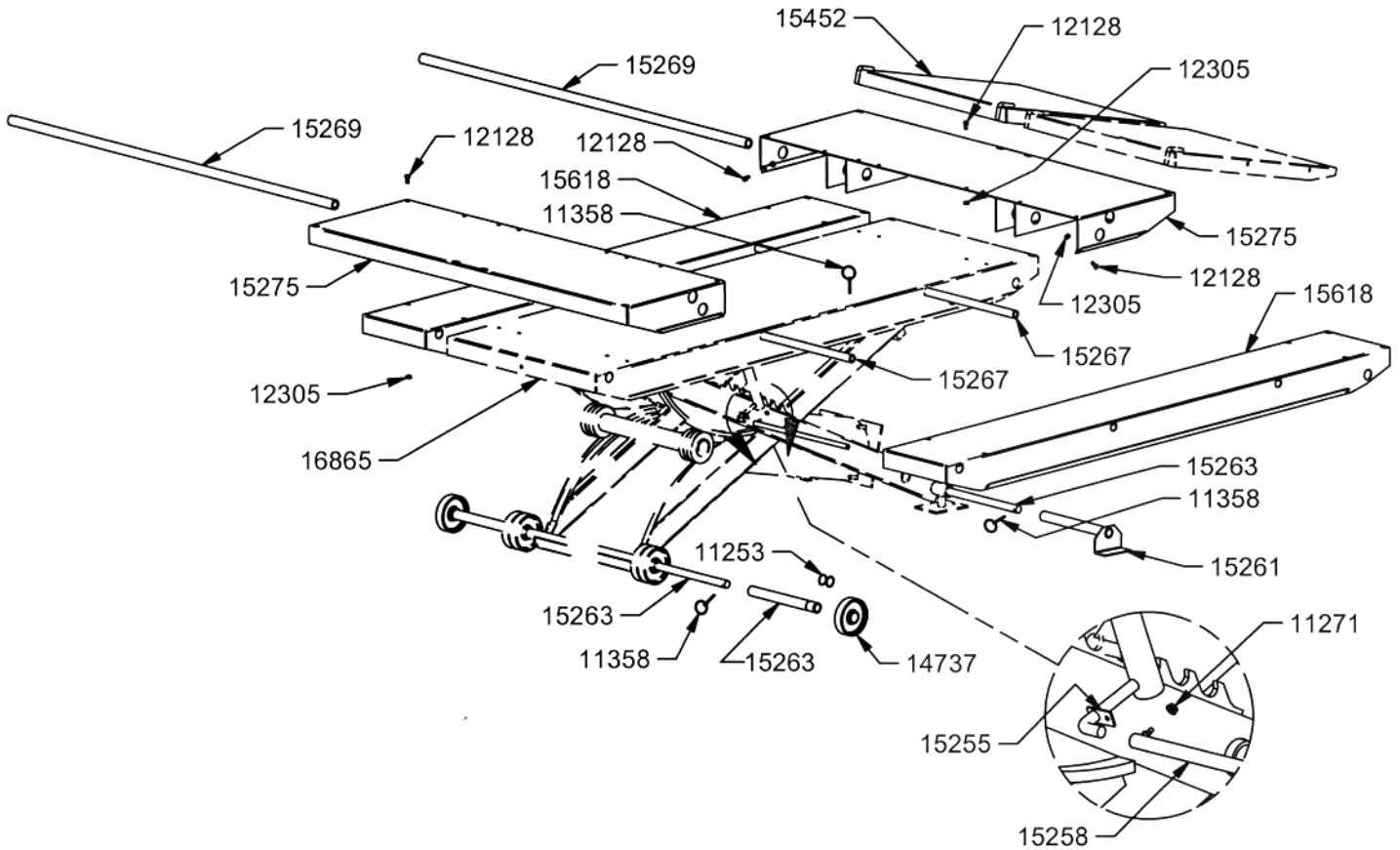

PART NO..	DESCRIPTION	QTY
11253	SPIRAL RETAINING RING	4
11271	10-32 HEX NUT	2
11358	QUIK PIN	12
12128	5/16-18 X 3/4 HEX HD CAP SCREW	20
12305	5/16-18 HEX NUT	20
14737	CAST WHEEL	2
15255	DETENT HANDLE EXTENSION RETAINER	2
15258	DETNET HANDLE EXTENSION TUBE	2
15261	SWIVEL STABILIZER FOOT	2
15263	AXLE EXTENSION	2
15265	STABILIZER SHAFT 53 1/4"	2
15267	3/4" PIPE EXTENSION 61 1/2" LONG	2
15269	1" PIPE EXTENSION 61 1/2" LONG	2
15275	END EXTENSION ASSEMBLY	2
15452	RAMP ASSEMBLY (ONE COMES WITH 16865)	1
15618	SIDE EXTENSION	2
16865	LIFT GRUNTAVOR	1



GRUNTAVORE

PARTS DRAWING - PARTS LIST

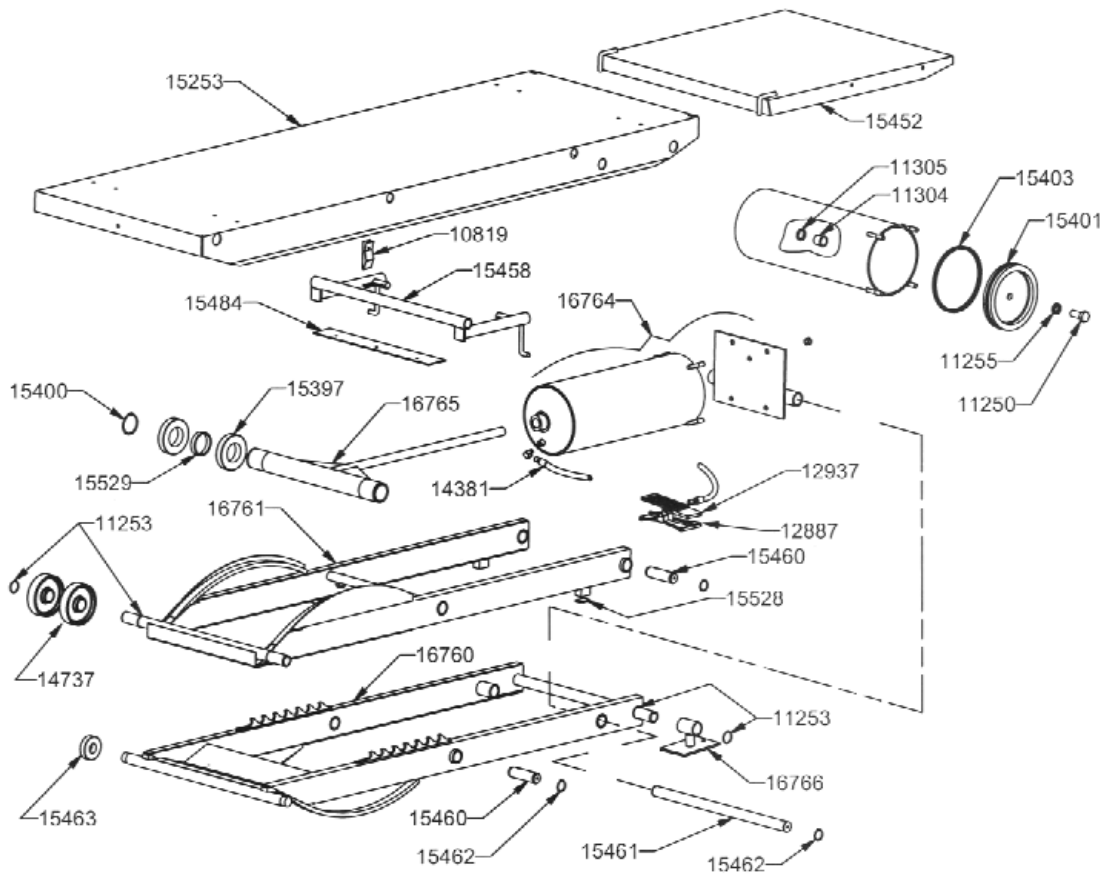

Part #	Description
10819	detent clip
14381	air hose assembly
11250	screw 3/4 -10 x 1-3/4
11253	retaining ring 1-5/16
11255	lockwasher - 3/4"
14737	wheel
12887	valve stem assembly
12937	foot valve assembly complete
11304	cylinder shaft bushing
11305	cylinder shaft seal
16764	cylinder assembly
15397	cam roller bearing
16765	cylinder shaft assembly
15400	retaining ring 2-3/8"
15401	piston

Part #	Description
15403	piston seal
15253	top assembly
16761	inside frame assembly
16760	outside frame assembly
16766	foot assembly
15452	ramp
15687	drop out cover
15458	detent bar
15460	frame pivot shaft
15461	cylinder pivot shaft
15462	retaining ring 1-1/4"
15463	track roller bearing
15484	cover plate
15528	rubber pad
15529	spacer

LIFT LIMITED WARRANTY

Handy Industries, LLC, warrants to the original purchaser of this Air Lift, all parts to be free from defects in manufacture for a period of ninety days from date of delivery. Notice of defective part must be received in writing at Handy Industries, LLC., and which upon our examination shall prove defective in manufacture or workmanship, will be replace or put in good operating condition. This warranty does not apply to damage resulting from accident or to any lift which has been improperly installed or repaired, neglected or operated contrary to instruction. The cost of such replacement or repair shall be exclusive remedy for any breach of any warranty and Handy Industries, LLC. shall not be liable to any person for consequential damage, or injury, or commercial loss resulting from any breach of warranty of merchantability, makes no warranty of fitness for a particular purpose and makes no other warranty expressed or implied, including implied warranty arising from the course or dealing or usage of the trade.