



MicroFlip Screen

Ultra-Portable Front Projection Screen with
StarBright7 Material

User Guide



Attention:

The StarBright7 screen material used in the MicroFlip Screen is composed of high quality sensitive multi-layer projection material.

Please follow the pre-cautions below for proper care procedures and to prolong the life of your StarBright7 material.

Failure to comply will result in voiding your warranty.

Avoid using any chemical compounds or harsh abrasives which will result in permanently damaging the screen material.

📌 USE ONLY a soft non-abrasive cloth with mild soap and water to clean the screen material

📌 DO NOT rub the cloth with force when cleaning to avoid permanently scratching the surface

📌 DO NOT touch the screen surface with sharp objects

📌 USE ONLY a soft feathered brush to remove dust

MicroFlip Screen Set-up instructions

Step 1: Open the MicroFlip Screen

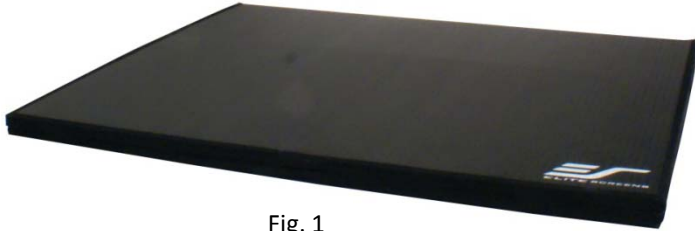

MicroFlip Screen closed

Fig. 1

Step 2: Flip the back part (see fig.2) and use the magnetic clasp hold the MicroFlip screen's position.

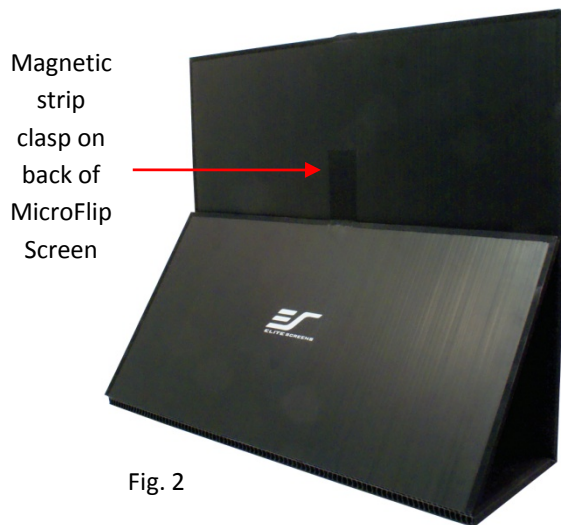

Magnetic strip clasp on back of MicroFlip Screen

Fig. 2

Step 3: Angle the screen as needed by sliding the back part of the MicroFlip screen UP or DOWN.



Fig. 3

MicroFlip Screen Dimensions Table

Unit: mm														
Model	Screen Diag/Aspect Ratio	Overall Width (A)	View Width (A1)	Overall Length (B)	View Height (B1)	Height at max. angle (B2)	Height at min. angle (B3)	B4	B5	C	C1	Depth (C)	Min. angle (α)	Max. angle (β)
PB15G7	15" (4:3)	315	305	546	229	248	271	272	160	118	118	6	65°	95°
PB17G7	17.5" (4:3)	366	356	624	267	283	311	312	190	128	128	6	65°	95°
PB20G7	20" (4:3)	416	406	680	305	308	339	340	190	156	156	6	65°	95°
Unit: inch														
Model	Screen Diag/Aspect Ratio	Overall Width (A)	View Width (A1)	Overall Length (B)	View Height (B1)	Height at max. angle (B2)	Height at min. angle (B3)	B4	B5	C	C1	Depth (C)	Min. angle (α)	Max. angle (β)
PB15G7	15" (4:3)	12.4	12.0	21.5	9.0	9.8	10.7	10.7	6.3	4.6	4.6	0.2	65°	95°
PB17G7	17.5" (4:3)	14.4	14.0	24.6	10.5	11.1	12.2	12.3	7.5	5.0	5.0	0.2	65°	95°
PB20G7	20" (4:3)	16.4	16.0	26.8	12.0	12.1	13.3	13.4	7.5	6.1	6.1	0.2	65°	95°

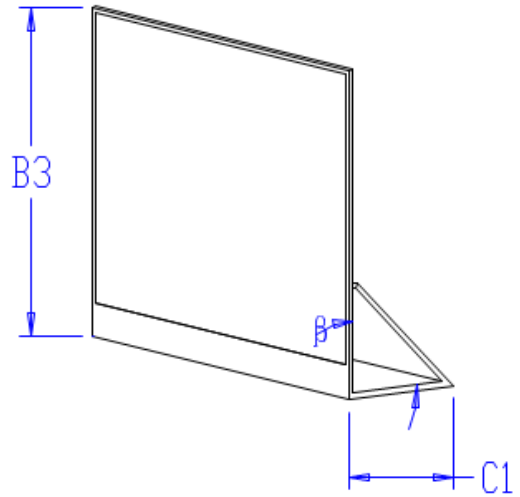
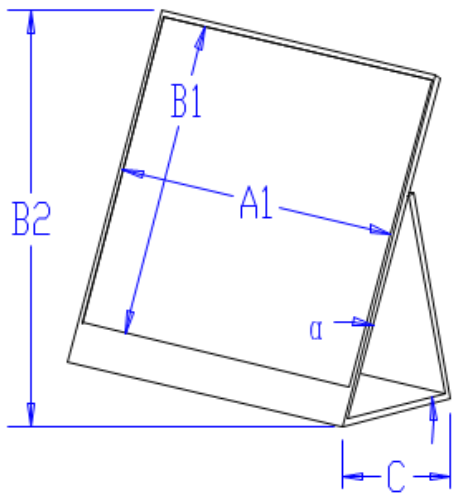

MicroFlip Expanded

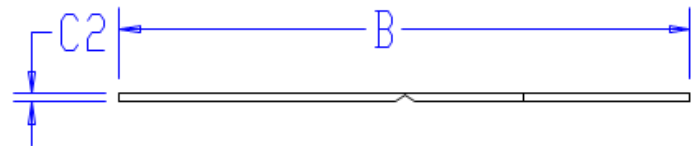
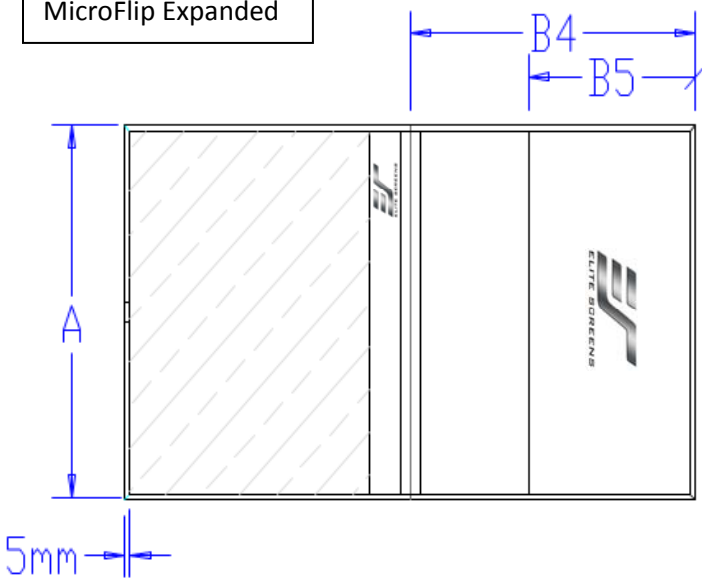

Register your warranty at www.elitescreens.com/register.html

US & Canada Tech Support & Warranty Claim

Please contact us at service@elitescreens.com or call +1 877-511-1211 #3 Service

Europe Tech Support & Warranty Claim

Please contact us at service@elitescreens.eu or call +49-(0) 40-30392958

Asia or China Tech Support & Warranty Claim

Please contact us at service@elitescreens.com.cn or call +86-(0) 755-8461-7989

Taiwan Tech Support & Warranty Claim

Please contact us at service@elitescreens.com.tw or call +886-(02)2747-8979

America: Elite Screens Inc

16410 Manning Way, Cerritos, CA 90703 USA

Tel: 877-5111211 Fax: 562-483-8498

info@elitescreens.com

www.elitescreens.com

Europe: Elite Screens Europe GmbH

Lübecker Straße, 122087 Hamburg, Germany

Tel: +49-40-30392494 Fax: +49-40-49219200

info@elitescreens.eu www.elitescreens.eu

Asia: Elite Screens China Ltd.

Longxi Duimianling Industry Zone Longcheng

Longgang District, ShenZhen GuangDong, China

Tel: +86-(0)755-8461-7989 Fax: +86-(0)755-8461-7669

info@elitescreens.com.cn

www.elitescreens.com.cn

Taiwan: Elite Screens Taiwan Corp.

1F. No. 38 Alley 22 Lane 66 Sec. 5 Nanjing E. Rd.

Songshan District. Taipei City 105, Taiwan

Tel: +886-(02)2747-8979 Fax: +886-(02)2747-8978

info@elitescreens.com.tw

www.elitescreens.com.tw

Email contacts:

Latin America Contact:

erik.garcia@elitescreens.com

East Asia Contact:

info.ea@elitescreens.com

India Contact:

info.india@elitescreens.com

Japan Contact:

info.japan@elitescreens.com