



**INSTALLATION INSTRUCTIONS**

PLEASE study these instructions carefully before installing your EGR Adapter kit. If you have any questions or problems, contact our Technical Hotline at: 1-800-416-8628 , 7am - 5pm, Monday-Friday, Pacific Standard Time or e-mail us at [edelbrock@edelbrock.com](mailto:edelbrock@edelbrock.com).

DESCRIPTION: This adapter kit is intended for the customer who already has a set of headers in his truck that he wishes to re-use with his new Vortec engine.

**KIT CONTENTS**

Qty.	Description
1	Vortec EGR Supply Fitting (#24-9715)
1	.75" O.D. x 1.25" Long, Bent Tube (#79-9643)
1	.75" O.D. x 6" Long, Bent Tube (#79-9574)

**PARTS REQUIRED**

Qty.	Description
1	GM #10220275 EGR Supply Tube
1	GM #12552329 Adapter Fitting

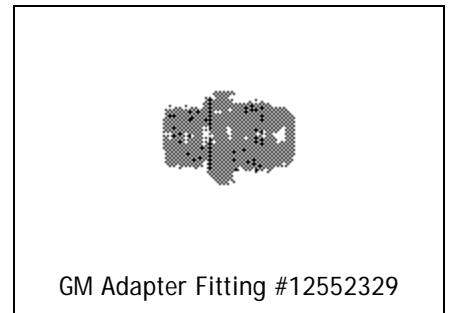
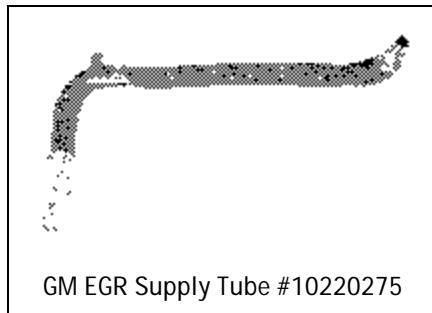
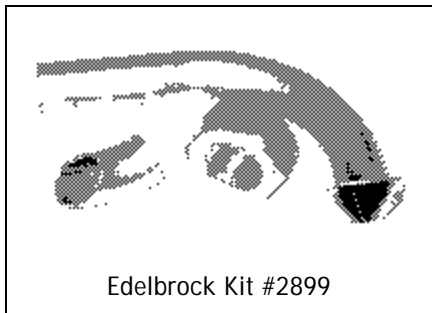

**INSTALLATION INSTRUCTIONS**

1. Attach GM EGR Supply Tube (#10220275) and GM Adapter Fitting (#12552329) to intake manifold (See Fig. 1). Do not tighten at this time!
2. Attach supplied EGR Supply Fitting to the GM Adapter Fitting (See Fig. 1). Do not tighten.
3. Using one of the Edelbrock bent tubes at a time, position the tubes against the under side of the fitting and against the side of the header primary tube. (Use the tube that allows the EGR-supply tube to be positioned in the vehicle so it has adequate clearance around other components). Bent tubes can be trimmed as needed (See Fig. 1).
4. Once you have selected the tube that fits your application best, remove the Edelbrock fitting from the EGR-supply tube and weld the fitting to the selected bent tube.
5. Re-install the fitting with the welded on tube and position the tube opening against the header primary tube, mark the primary tube, remove the header and drill a 1/2" diameter hole where you have marked.
6. For best fit, re-install the header into position, re-install the fitting onto the EGR-supplied tube and tack weld.
7. Remove the header and complete the weld.
8. Re-install header with new gaskets and hardware. Tighten the GM adapter fitting into the welded on tube and fitting, and tighten the fittings on both ends of EGR-supply tube.

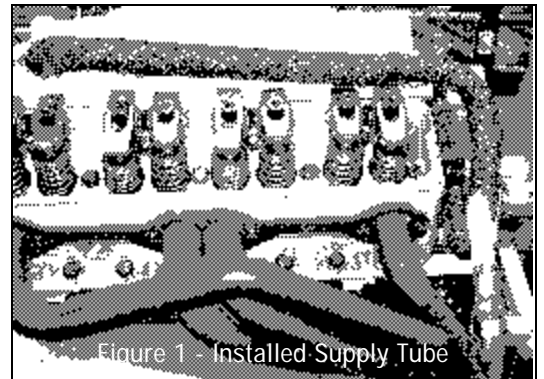

**WARNING!!!**

*Exhaust gas contains carbon monoxide, a deadly invisible gas. Correct any leaks before driving!*

Edelbrock Corporation • 2700 California Street • Torrance, CA 90503  
Toll-Free Tech Line: 1-800-416-8628  
Tech E-Mail: [edelbrock@edelbrock.com](mailto:edelbrock@edelbrock.com)