

## E-TBT-MC04 10Base-T Transceiver

- **Stand-Alone model**
- **Attached Unit Interface (AUI) to Ethernet RJ-45 connectors**
- **No external power requirement**

The E-TBT-MC04 transceiver is a media access unit (MAU) that connects the AUI port of data terminal equipment, repeaters, or other network

devices either directly or through an AUI cable to an Ethernet 10BASE-T device. The Ethernet device is connected to the transceiver through an unshielded or shielded twisted-pair copper cable with RJ-45 connector ends.

## Various Transceiver System Configurations

Figure 1 shows various examples of transceiver system configurations.

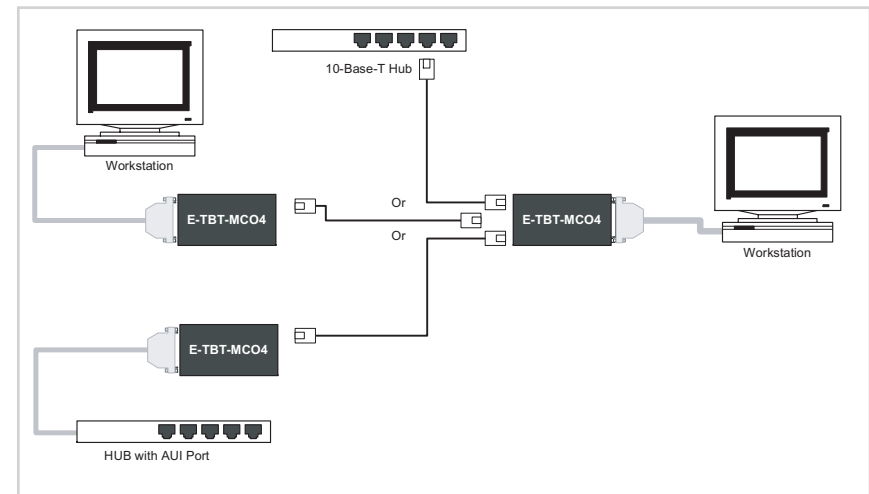

**Figure 1: Transceiver System Configurations**

General Description	2
Connectors & Cables	3
Installation	6
Operations	8
Technical Specifications	9
Cable Specifications	10
Troubleshooting	10
Contact Us	11

## General Description

The E-TBT-MC04, IEEE802.3 compliant Ethernet transceiver uses 10Mbps Ethernet CSMA/CD protocol to provide a connection interface to 10Base-T Ethernet unshielded twisted-pair (UTP) cables. The transceiver connects to the AUI connector of an Ethernet device via standard AUI cable.

Figure 2 shows the front and rear panels of the E-TBT-MC04 transceiver.

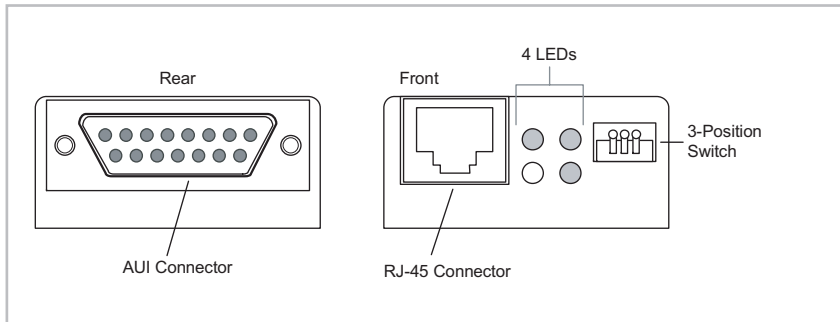

**Figure 2: E-TBT-MC04 Transceiver Front and Rear Panels**

## Dimensions

Figure 3 shows the E-TBT-MC04 dimensions.

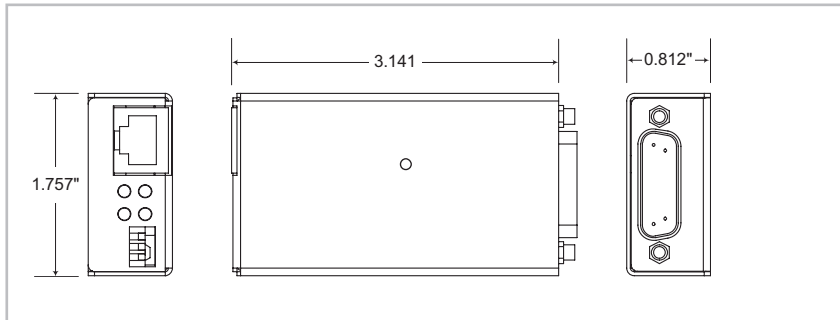

**Figure 3: E-TBT-MC04 Dimensions**

## E-TBT-MC04 Features

- Provides a complete interface of the AUI to Ethernet UTP cable.
- Supports 10Mbps data transfer rates.
- Supports Carrier Sense Multiple Access/Collision Detection (CSMA/CD) contention protocol.
- Drives UTP cable segments up to 100 meters (328ft).
- Supports selectable link and SQE test functions.
- Supports direct connections to host AUI ports.
- Detects and corrects reverse polarity on the receiving pair of UTP cables.
- Provides four LEDs: Transmit (TX), Receive (RX), Collision, and Status.

## Connectors and Cables

### E-TBT-MC04 AUI male connector

AUI D-sub 15-pin male connector accommodates AUI drop cables (50 meters max.). The AUI connector is used to connect the transceiver to the AUI port of an Ethernet device such as an Ethernet MAC controller, a repeater, or a hub via an AUI drop cable. The AUI connector is shown in Figure 4. The AUI male connector pin assignments are shown in Table 1.

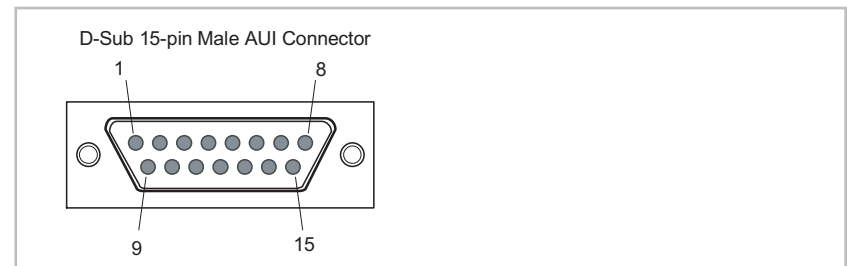

**Figure 4: E-TBT-MC04 AUI Male Connector Pin Assignments**

## Connectors & Cables -- Continued

### AUI connector -- continued

Table 1: AUI Male Connector Pinouts

Pin	Name	Pairs	Use
3	DO +	Transmit	Data Out +
10	DO -	Pair	Data Out -
11	DO S		Data Out Shield
5	DI +	Receive	Data In +
12	DI -	Pair	Data In -
4	DI S		Data In Shield
7	CO +	Option	Control Out +
15	CO -	Pair	Control Out -
8	CO S		Control Shield
2	CI +	Collision	Control In +
9	CI -	Pair	Control In -
1	CI S		Control Shield
6	VC	Power	Voltage Common
13	VP	Pair	Voltage Plus
14	VS		Voltage Shield

### UTP cable (RJ-45 connector)

The 10Base-T, RJ-45 out jack is used to connect a 10Base-T Ethernet device via a 2-pair UTP cable. (Use category 3, 4, or 5 UTP cable.) The length of the UTP cable can be up to 100m (328ft).

The RJ-45 connector pin configuration is shown in Figure 5. The pin assignments are show in the Table 2..

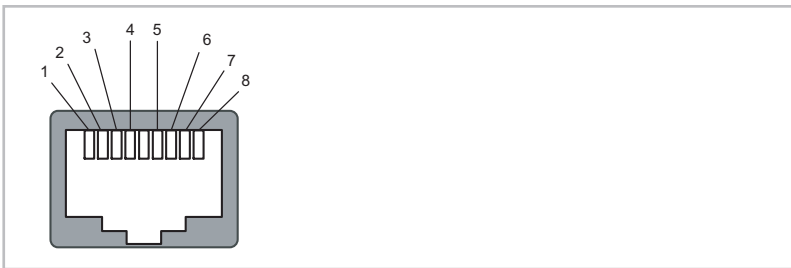

Figure 5: RJ-45 Connector Pin Configuration

## Connectors & Cables -- continued

### UTP cable (RJ-45 connector) -- continued

Table 2: RJ-45 Pin Assignments

Pin	Out Jack Assignments
1	Outgoing Data 1 (+)
2	Outgoing Data 2 (-)
3	Incoming Data 1 (+)
4	Not connected
5	Not connected
6	Incoming Data 2 (-)
7	Not connected
8	Not connected

### Wiring schemes for UTP cable and devices

How to install the UTP cable is determined by the characteristics of the 10Base-T UTP port of the other device. The following shows some pinning examples:

#### UTP Cable Pin Wiring

	Pin		Pin
	1	-----	1
	2	-----	2
Transceiver	3	-----	3
	6	-----	6
	Pin		Pin
	1	-----	3
	2	-----	6
			• 10Base-T C

**Note:** The device 10Base-T output jack is normally used to connect to another 10Base-T device. The vendor's 10Base-T device sometimes provides a crossover option to set the jack as an input jack for connecting to a 10Base-T Ethernet station.

## Installation

### Switches

The E-TBT-MC04 has a 3-position DIP switch. See Figure 6. Two of the switches provide options for enabling and disabling the SQE test and LINK test functions. Both test functions are Ethernet and 10Base-T standards.

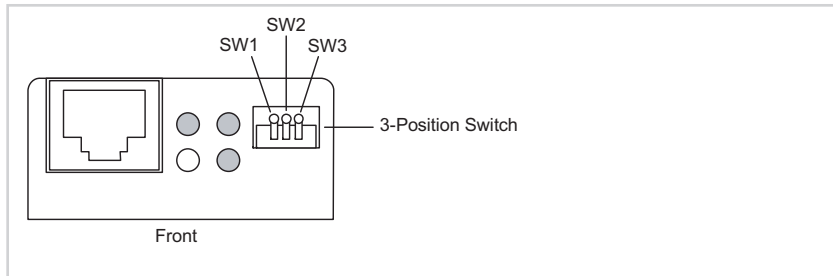

**Figure 6: E-TBT-MC04 Three-Position Switch**

The following describes the switch settings:

SW1 = SQE test: UP is enabled/DOWN is disabled

SW2 = Link test: UP is enabled/DOWN is disabled

SW3 = Duplex: UP is half/DOWN is full

### SQE test

The transceiver is shipped from the factory with the SQE test switch enabled. SQE (*Signal Quality Error*) is the IEEE term for collisions. Depending on the Ethernet device attached to the AUI connector, set the SW “1” to the DOWN position to disable the SQE test function or to the “UP” position to enable the test.

The SQE Test (*heartbeat*) is a means of detecting a transceiver’s inability to detect collisions. Without this test, it would not be possible to determine if the collision detector is operating properly. The SQE test starts by generating a test signal on the collision pair from the transceiver (*or its equivalent*) following every transmission on the network. It does not generate any signals on the common medium.

Additionally, IEEE 802.3 specifications state that IEEE 802.3 compliant repeaters must not be attached to transceivers that generate the heartbeat.

### Link test

For UTP port connection, the E-TBT-MC04 implements the link integrity test functions as specified in the IEEE 802.3 10Base-T standard. The E-TBT-MC04 will transmit link test pulses to any UTP port after that port’s transmitter is inactive for a range of 8 to 17 ms. These pulses are sent to confirm that a valid connection exists between the E-TBT-MC04 and its attached device.

## Installation -- Continued

### Connecting to a Device AUI port

The E-TBT-MC04 can connect to any Ethernet device with an AUI port. To connect to a device with an AUI port, an AUI cable or direct connection is required. See Figure 7.

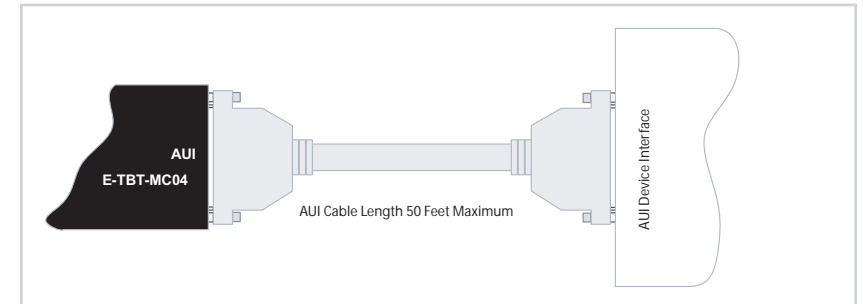

**Figure 7: E-TBT-MC04 Connected to an AUI Device Port**

### Connecting to an RJ-45 device jack

**IMPORTANT:** If the transceiver is attached to an Ethernet repeater, a 10Base-T hub, or a wiring concentrator, the SQE test function should be disabled.

To connect the transceiver to a 10Base-T device via RJ-45 jacks, see Figure 8 and do the following:

1. Select an appropriate length UTP cable for the connection.
2. Connect one end of the UTP cable to the RJ-45 OUT jack of the transceiver.
3. Route the free end of the UTP cable to the area where the 10Base-T device is located.
4. Connect the free end of the UTP cable to an RJ-45 IN jack on the 10Base-T device.

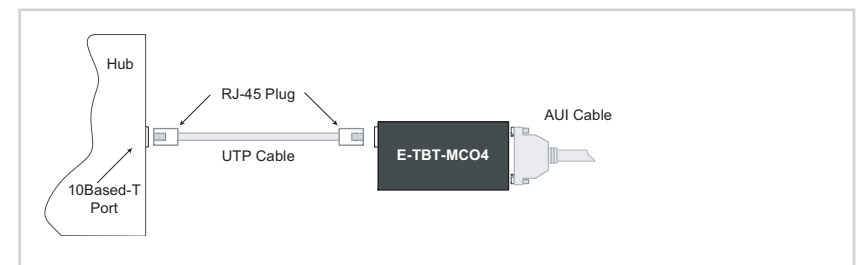
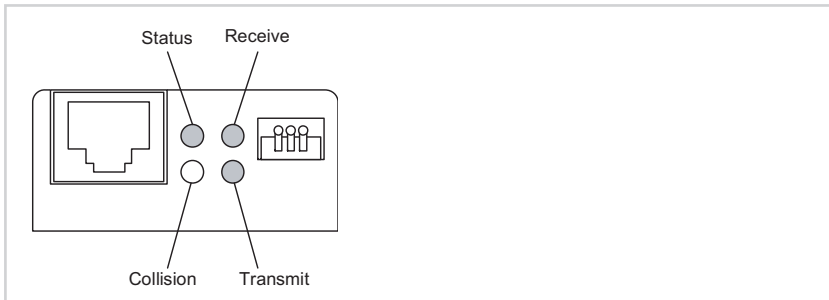

**Figure 8: E-TBT-MC04 Connected to a RJ-45 Device Jack**

## Operations

### LEDs

Figure 9 shows the E-TBT-MC04 LEDs:



**Figure 9: E-TBT-MC04 LEDs**

The E-TBT-MC04 LEDs display the operational status of the transceiver. The following table explains LED indications.

LED	Description
Collision	Blinks when detects a collision
Status	ON Solid: UTP link established Blinks: No UTP link 5-Blink pattern: UTP polarity reversal*
Transmit	Blinks when transmitting data on the RJ-45 cable
Receive	Blinks when receiving data on the RJ-45 cable

**\*Note:** The E-TBT-MC04 corrects reverse polarity on its receiving port UTP cable automatically.

## Technical Specifications

For use with Transition Networks' Model E-TBT-MC04 or equivalent.

Standards	IEEE 802.3ab, IEEE 802.3
Data Rate	10 Mb/s
Dimensions	1.77" x 0.81" x 3.14" (44.96 mm x 20.57mm x 79.76mm)
Weight	0.2 lbs. (90.72 g) approximately
Power Consumption	Not to exceed 75mA @ 12VDC
Power Source	AUI port, 500 mA @ 12VDC
Operating Temp	0 to 50°C (32°F to 122°F)
Storage Temp:	-25 to 85°C (-13°F to 185°F)
Humidity:	5 to 95%, non-condensing
Altitude:	0 to 10,000 feet
MTBF:	125,126 Bellcore hours. Calculated at 40C with a 10C temperature rise.
Warranty	Lifetime

**Note:** The information in this user's guide is subject to change. For the most up-to-date information on the E-TBT-MC04 Transceiver, view the user's guide online at: [www.transition.com](http://www.transition.com).

**IMPORTANT** Copper based media ports: e.g., Twisted Pair (TP) Ethernet, USB, RS232, RS422, RS485, DS1, DS3, Video Coax, etc. are intended connecting to intra-building (*inside plant*) link segments, not subject to lightning transients or power faults. Copper based media ports: e.g., Twisted Pair (TP) Ethernet, USB, RS232, RS422, RS485, DS1, DS3, Video Coax, etc. are NOT for connecting inter-building (*outside plant*) link segments that are subject to lightning transients or power faults. Failure to observe this notice could result in damage to equipment.

## Cable Specifications

The physical characteristics of the media cable must meet or exceed IEEE 802.3 specifications.

### Copper cables

Category 3: (*minimum requirement*)

Gauge	24 to 22 AWG
Attenuation	11.5 dB/100m @ 5-10 MHz
Maximum cable distance:	100 m

Category 5: (*recommended*)

Gauge	24 to 22 AWG
Attenuation	22.0 dB/100m @ 100 MHz
Maximum cable distance:	100 m

- Straight-through or crossover twisted-pair cable may be used.
- Shielded (STP) or unshielded (UTP) twisted-pair cable may be used.
- Pins 1&2 and 3&6 are the two active pairs in an Ethernet network .
- RJ-45 Pin-out: Pin 1 = TD+, Pin 2 = TD-, Pin 3 = RD+, Pin 6 = RD-
- Use only dedicated wire pairs for the active pins:  
(*e.g., blue/white & white/blue, orange/white & white/orange, etc.*)
- Do not use flat or silver satin wire.

## Troubleshooting

If the transceiver fails, determine the answer to the following questions:

1. Is the status LED flashing?  
NO
  - Verify that the AUI device is turned ON.
  - Verify that the AUI cable from the transceiver to the AUI device port is installed properly.
  - Contact Tech Support: 1-800-260-1312, Int'l: 00-1-952-941-7600.
 YES
  - Go to step 2.
2. Is the RX LED flashing (*receiving data*)?  
NO
  - Is the LED ON Solid?
  - Check twisted pair cable for proper connection
  - Contact Tech Support: 1-800-260-1312, Int'l: 00-1-952-941-7600.
 Yes
  - Go to step 3.
3. Is the TX LED ON?  
NO
  - Check twisted pair cable for proper connection.
  - Is the LED flashing (*transmitting data*)?
  - Restart the hardware to force re-initialization.
  - Contact Tech Support: 1-800-260-1312, Int'l: 00-1-952-941-7600.
 Yes
  - Contact Tech Support: 1-800-260-1312, Int'l: 00-1-952-941-7600.

## Contact Us

### Technical support

Technical support is available 24 hours a day.

US and Canada:	1-800-260-1312
International:	00-1-952-941-7600

### Transition now

Chat live via the Web with Transition Networks Technical Support.  
Log onto [www.transition.com](http://www.transition.com) and click the Transition Now link.

### Web-based seminars

Transition Networks provides seminars via live web-based training.  
Log onto [www.transition.com](http://www.transition.com) and click the Learning Center link.

### E-Mail

Ask a question anytime by sending an e-mail to our technical support staff at [techsupport@transition.com](mailto:techsupport@transition.com)

### Address

Transition Networks: 10900 Red Circle Drive, Minnetonka MN 55343, U.S.A.  
telephone: 952-941-7600; toll free: 800-526-9267; fax: 952-941-2322

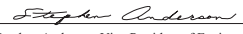
		<b>Declaration of Conformity</b>
Name of Mfg:	Transition Networks 10900 Red Circle Drive, Minnetonka MN 55343 U.S.A.	
Model:	E-TBT-MC04 Transceiver	
Part Number(s):	E-TBT-MC04	
Regulation:	EMC Directive 89/336/EEC	
Purpose: To declare that the E-TBT-MC04 Transceiver to which this declaration refers is in conformity with the following standards. EN55022:1998 + A1:2000 + A1:2003 EN 55024:1998 + A1:2000 + A2:2003		
I, the undersigned, hereby declare that the equipment specified above conforms to the above Directive(s) and Standard(s).		
 Stephen Anderson, Vice-President of Engineering		August, 2008 Date

# Compliance Information

## CE Mark

### FCC regulations

This equipment has been tested and found to comply with the limits for a Class A&B digital device, pursuant to part 15 of the FCC rules. These limits are designed to provide reasonable protection against harmful interference when the equipment is operated in a commercial environment. This equipment generates, uses, and can radiate radio frequency energy and, if not installed and used in accordance with the instruction manual, may cause harmful interference to radio communications. Operation of this equipment in a residential area is likely to cause harmful interference, in which case the user will be required to correct the interference at the user's own expense.

### Canadian regulations

This digital apparatus does not exceed the Class A&B limits for radio noise for digital apparatus set out on the radio interference regulations of the Canadian Department of Communications.

Le présent appareil numérique n'émet pas de bruits radioélectriques dépassant les limites applicables aux appareils numériques de la Class A&B prescrites dans le Règlement sur le brouillage radioélectrique édicté par le ministère des Communications du Canada.

## European Regulations

### Warning

This is a Class A product. In a domestic environment this product may cause radio interference in which case the user may be required to take adequate measures.

### Achtung !

Dieses ist ein Gerät der Funkstörgrenzwertklasse A. In Wohnbereichen können bei Betrieb dieses Gerätes Rundfunkstörungen auftreten. In diesem Fall ist der Benutzer für Gegenmaßnahmen verantwortlich.

### Attention !

Ceci est un produit de Classe A. Dans un environnement domestique, ce produit risque de créer des interférences radioélectriques, il appartiendra alors à l'utilisateur de prendre les mesures spécifiques appropriées.



In accordance with European Union Directive 2002/96/EC of the European Parliament and of the Council of 27 January 2003, Transition Networks will accept post usage returns of this product for proper disposal. The contact information for this activity can be found in the 'Contact Us' portion of this document.



CAUTION: RJ connectors are NOT INTENDED FOR CONNECTION TO THE PUBLIC TELEPHONE NETWORK. Failure to observe this caution could result in damage to the public telephone network.

Der Anschluss dieses Gerätes an ein öffentliches Telekommunikationsnetz in den EG-Mitgliedstaaten verstößt gegen die jeweiligen einzelstaatlichen Gesetze zur Anwendung der Richtlinie 91/263/EWG zur Angleichung der Rechtsvorschriften der Mitgliedstaaten über Telekommunikationsendeinrichtungen einschliesslich der gegenseitigen Anerkennung ihrer Konformität.

## Trademark notice

All trademarks and registered trademarks are the property of their respective owners.

## Copyright restrictions

© 2000, 2004-2006 Transition Networks.

All rights reserved. No part of this work may be reproduced or used in any form or by any means—graphic, electronic, or mechanical—without written permission from Transition Networks.