

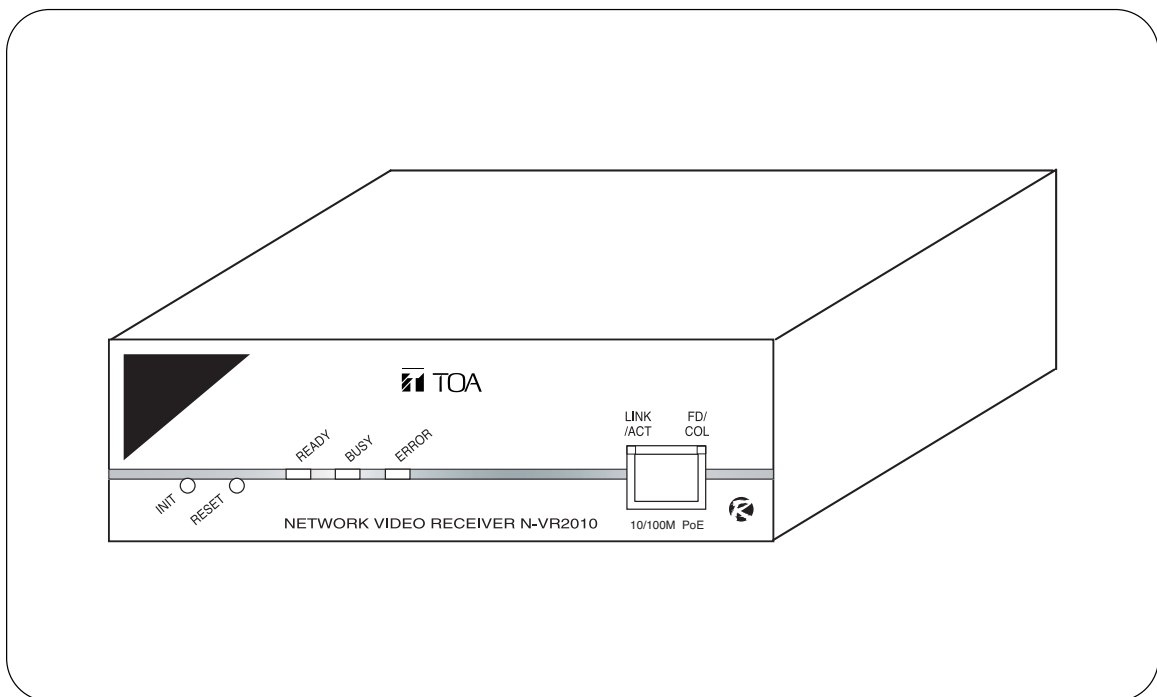

INSTRUCTION MANUAL

NETWORK VIDEO RECEIVER

N-VR2010



Thank you for purchasing TOA's Network Video Receiver.
Please carefully follow the instructions in this manual to ensure long, trouble-free use of your equipment.

TOA Corporation

TABLE OF CONTENTS

1. SAFETY PRECAUTIONS	3
2. LIST OF INCLUDED COMPONENTS AND PARTS	6
3. GENERAL DESCRIPTION	6
4. FEATURES	6
5. HANDLING PRECAUTIONS	7
6. SYSTEM CONFIGURATION	8
7. NOMENCLATURE AND FUNCTIONS	
[Front]	9
[Rear]	10
8. CONNECTIONS	
8.1. Connection example	11
8.2. Monitor Connection	12
8.3. Network Connection	12
8.4. Microphone Connection	12
8.5. Audio Signal I/O Connection	12
8.6. Contact Input and Output Terminals	12
8.7. Serial Port	13
8.8. DIP Switch Setting	14
9. SETTING INITIALIZATION	14
10. TROUBLESHOOTING	14
11. SPECIFICATIONS	15

SAFETY PRECAUTIONS

- Before installation or use, be sure to carefully read all the instructions in this section for correct and safe operation.
- Be sure to follow all the precautionary instructions in this section, which contain important warnings and/or cautions regarding safety.
- Keep this instruction manual handy for future reference.

Safety Symbol and Message Conventions

Safety symbols and messages described below are used in this manual to prevent bodily injury and property damage which could result from mishandling. Before operating your product, read this manual first and understand the safety symbols and messages so you are thoroughly aware of the potential safety hazards.



WARNING

Do not expose the unit to rain or an environment where it may be splashed by water or other liquids, as doing so may result in fire or electric shock.



WARNING

Indicates a potentially hazardous situation which could result in death or serious personal injury if ignored or mishandled.

When Installing the Unit

- This is a class A product. In a domestic environment this product may cause radio interference in which case the user may be required to take adequate measures.
- Use the unit only with the voltage specified on the unit. Using a voltage higher than that which is specified may result in fire or electric shock.
- Do not cut, kink, or otherwise damage or modify the power supply cord. Also, avoid using the power cord in close proximity to heaters, and never place heavy objects, including the unit itself, on the power cord as doing otherwise may result in fire or electric shock.
- Avoid installing or mounting the unit in unstable locations, such as on a rickety table or a slanted surface because a fire or electric shock may result.
- Since the unit is designed for in-door use, do not install it outdoors. If installed outdoors, the aging of parts causes the unit to fall off, resulting in personal injury. Also, when it gets wet with rain, there is a danger of electric shock.



WARNING

Indicates a potentially hazardous situation which could result in death or serious personal injury if ignored or mishandled.

When the Unit is in Use

- Should the following irregularity be found during use, immediately switch off the power, disconnect the power supply plug from the AC outlet and contact your nearest TOA dealer. Make no further attempt to operate the unit in this condition as this may cause fire or electric shock.
 - If you detect smoke or a strange smell coming from the unit.
 - If water or any metallic object gets into the unit
 - If the unit falls, or the unit case breaks
 - If the connection cable is damaged (exposure of the core, disconnection, etc.)
 - No sound output
 - If no camera images are displayed on the monitor TV
- To prevent a fire or electric shock, never open nor remove the unit case as there are high voltage components inside the unit. Refer all servicing to your nearest TOA dealer.
- Do not place cups, bowls or other containers of liquid or metal pieces on top of the unit. If they accidentally spill into the unit, this may cause a fire or electric shock.
- Do not insert nor drop metallic objects or flammable materials in the unit, as this may result in fire or electric shock.
- Do not touch a power supply plug during thunder and lightning, as this may result in an electric shock.



CAUTION

Indicates a potentially hazardous situation which could result in moderate or minor personal injury, and/or property damage if ignored or mishandled.

When Installing the Unit

- Never insert nor remove the power supply plug with wet hands, as an electric shock may result.
- When unplugging the power supply cord, be sure to grasp the power supply plug; never pull on the cord itself. The power supply cord may be damaged, possibly causing a fire or electric shock.
- When moving the unit, be sure to remove its power supply cord from the wall outlet. Moving the unit with the power cord connected to the outlet may cause damage to the power cord, resulting in fire or electric shock.
- Do not block the ventilation slots in the unit's cover. Heat may build up in the unit, causing a fire.
- Avoid installing the unit in humid or dusty locations, in locations exposed to the direct sunlight, near the heaters, or in locations generating sooty smoke or steam as doing otherwise may result in fire or electric shock.

When the Unit is in Use

- Do not place heavy objects on the unit as this may cause it to fall or break which may result in personal injury.
- If dust accumulates on the power supply plug or in the wall AC outlet, a fire may result. Clean them periodically. In addition, insert the plug in the wall outlet securely.
- Switch off the power and unplug the power supply plug from the AC outlet for safety purposes when cleaning or leaving the unit unused for 10 days or more. A fire or electric shock may result.

CU version complies with Part 15 of the FCC Rules.

Note

This equipment has been tested and found to comply with the limits for a Class A digital device, pursuant to Part 15 of the FCC Rules. These limits are designed to provide reasonable protection against harmful interference when the equipment is operated in a commercial environment. This equipment generates, uses, and can radiate radio frequency energy and, if not installed and used in accordance with the instruction manual, may cause harmful interference to radio communications. Operation of this equipment in a residential area is likely to cause harmful interference in which case the user will be required to correct the interference at his own expense.

Modifications

Any modifications made to this device that are not approved by TOA Corporation may void the authority granted to the user by the FCC to operate this equipment.

2. LIST OF INCLUDED COMPONENTS AND PARTS

Check to be sure that the following components and parts are contained in the package:

Power conversion cable	1
Network Video Receiver Instruction Manual	1

3. GENERAL DESCRIPTION

TOA's N-VR2010 Network Video Receiver can convert images transmitted by the digital signals on a LAN from a Network Camera or Network Video Transmitter into an analog composite signal and output it. MPEG-4 allows smooth moving images to be monitored.

The N-VR2010 can transmit bi-directional sub-band ADPCM or PCM quality voice. Its power supply features PoE compatibility in addition to 24V AC or 24V DC operation, permitting simplified wiring work and cable savings during construction by supplying power via the network.

The N-VR2010 has a 12V DC power output which supplies power to the equipment such as remote controllers.

Since the N-VR2010 is equipped with RS-232C and RS-485 connectors, it can remotely operate a Digital Video Recorder and Combination Dome Cameras connected to the Network Video Transmitter when used in combination with a Remote Controller.

4. FEATURES

- After receiving streamed MPEG-4 data, the Network Video Receiver decompresses and converts it into an analog signal, and then transmits the analog video signal.
- The Receiver is equipped with audio input and output (line/microphone input and line output) that enable two-way signal transmission.
- External connected equipment, such as the Digital Video Recorder, Multi-Switcher, and Combination Dome Camera can be controlled via the RS-232C/RS-485 interfaces.
- A built-in web server can be accessed using a web browser.
- The Receiver can function as a monitor system if the supplied software decoder is also used.
- Since the hub is compatible with PoE Standards, power can be supplied to the Network Video Receiver using a single network cable. This eliminates the necessity for preparing a separate power supply in each camera installation location, and greatly improves installation freedom. PoE (Power over Ethernet) (This complies with the IEEE802.3af standard and allows simultaneous transmission of both normal data and DC power using a 10BASE-T or 100BASE-TX network.)

5. HANDLING PRECAUTIONS

- Do not give the Receiver a great shock or vibration, as this will damage the Receiver.
- It is recommended that the Receiver be always used in locations where the ambient temperature ranges from -0°C to +50°C and humidity levels of less than 90% to ensure that no condensation is formed.
- To clean, wipe with a dry soft cloth. Never use benzene, thinner or chemically processed towel as the Receiver's plastic or other parts may be deformed or discolored.
- Installing the camera cables and monitor cables in close proximity to fluorescent lamps or other electrical appliances can downgrade the picture quality. In such cases, change the wiring.
- If there is a strong electric or magnetic field near the Receiver, such as television transmission antennas, motors or transformers, this may distort or roll the monitor picture. In such cases, run the entire wiring route through metal conduit tubing.
- Shielded (STP) network cables must be used with this unit to ensure compliance with EMC standards.
- Secure sufficient space for cable installation.
- Install the Receiver in well-ventilated locations.
- Use appropriate cables to prevent electrical failures.
- Install cables so as to prevent their damage and provide ample cable slack if they need to be stretched taut.
- The IP address, subnet mask and gateway IP address must be set.
- When a connection is established between the Transmitter and multiple Receivers, if the data rate requested by each Receiver differs, the transmission will be limited to the minimum set data rate.
- Personal computers running Microsoft Windows XP are required when setting the Network Video Receiver.
- TOA's software decoder does not support Macintosh or Unix operating systems.

MPEG-4 visual patent portfolio license

THIS PRODUCT IS LICENSED UNDER THE MPEG-4 VISUAL PATENT PORTFOLIO LICENSE FOR THE PERSONAL AND NON-COMMERCIAL USE OF A CONSUMER FOR (1) ENCODING VIDEO IN COMPLIANCE WITH THE MPEG-4 VISUAL STANDARD ("MPEG-4 VIDEO") AND/OR (2) DECODING MPEG-4 VIDEO THAT WAS ENCODED BY A CONSUMER ENGAGED IN A PERSONAL AND NON-COMMERCIAL ACTIVITY AND/OR WAS OBTAINED FROM A VIDEO PROVIDER LICENSE BY MPEG LA TO PROVIDE MPEG-4 VIDEO. NO LICENSE IS GRANTED OR SHALL BE IMPLIED FOR ANY OTHER USE. ADDITIONAL INFORMATION INCLUDING THAT RELATING TO PROMOTIONAL, INTERNAL AND COMMERCIAL USES AND LICENSING MAY BE OBTAINED FROM MPEG LA, LLC.

SEE [HTTP://WWW.MPEGLA.COM](http://www.mpegla.com).

6. SYSTEM CONFIGURATION

The connection of a basic system is shown below.

The analog CCTV system is comprised of conventional cameras and switchers.

When using a PoE-compatible hub, the power supply need not be connected to the N-VT2010 Network Video Transmitter, N-VR2010 Network Video Receiver and N-CC2360 Network Color camera. When using a hub not supporting PoE, power must be independently supplied to each device. Connect the AC mains to N-DR2000 Network Video Recorder.

Connect 24V AC to the N-CC2564 Network Combination Dome Camera.

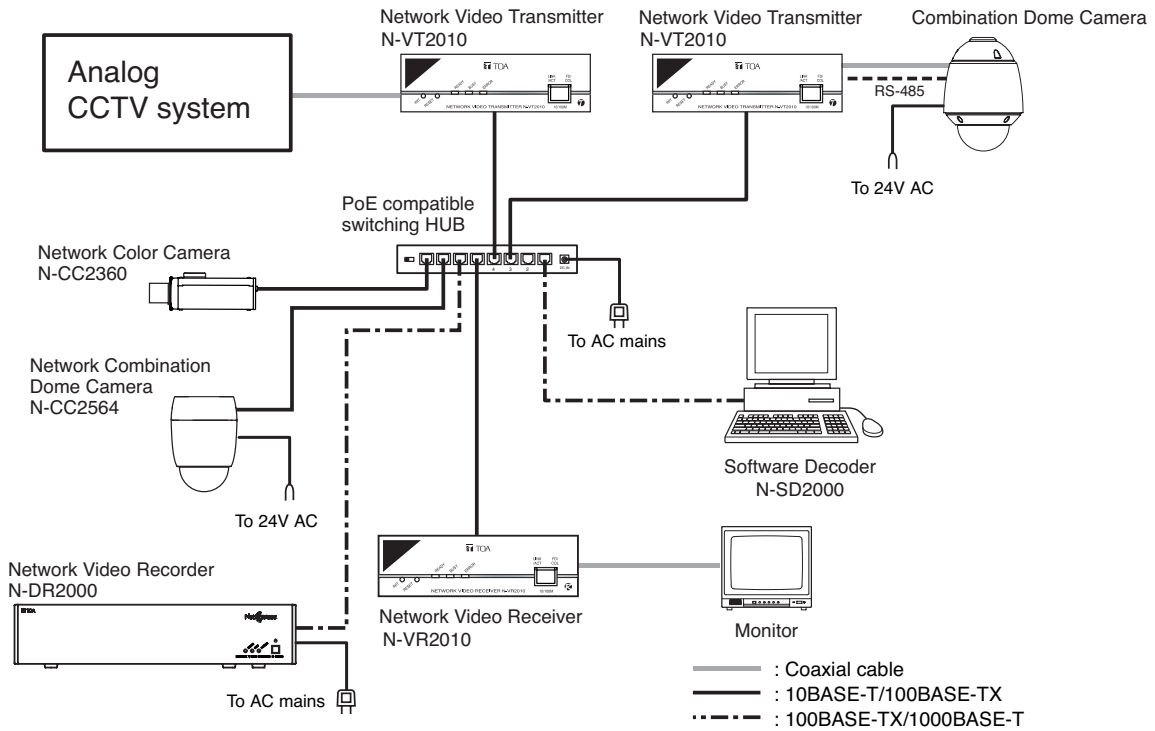

7. NOMENCLATURE AND FUNCTIONS

[Front]

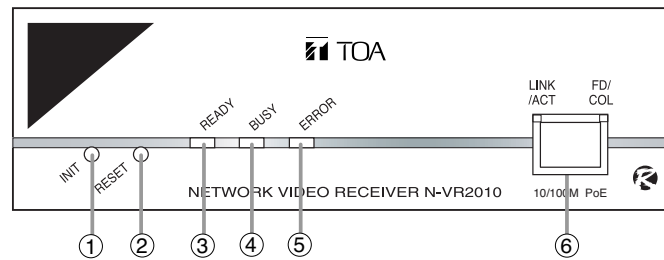

(1) Initialization Key [INIT]

Initializes the setting contents to default conditions.

(2) Reset Key [RESET]

Restarts the Receiver.

(3) Ready Indicator (Green)

Lights continuously while the Receiver is operating. The indicator flashes quickly when the Receiver is set to start mode, and flashes slowly during firmware update.

(4) Busy Indicator (Yellow)

Lights continuously during communications.

(5) Error Indicator (Red)

Lights when the Receiver's operation stops due to equipment failure. The indicator extinguishes when the Receiver automatically resets and returns to normal.

(6) Network Terminal (RJ-45)

Connect this terminal to a 10BASE-T or 100BASE-TX compatible network.

• LINK/ACT (Green)

Lights when the network is correctly connected, and flashes while data is being transmitted or received

• FD/COL (Yellow)

Lights continuously while the Receiver is operating in full-duplex mode, and remains unlit while the Receiver is in half-duplex mode. The indicator flashes when a data collision occurs over the network.

[Rear]

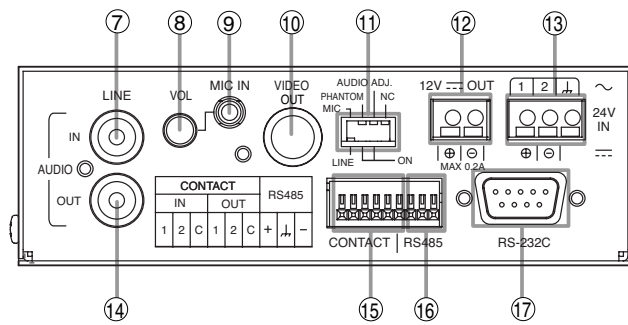

(7) Audio Input Terminal (-10 dB, 10 kΩ, unbalanced type)
Receives line level audio signals.

(8) Microphone Input Volume Control
Adjusts the microphone input level.

(9) Microphone Input Terminal (-60 dB, 2.2 kΩ)
Inputs signals from the microphone. 9V can be supplied for phantom power supply.

(10) Video Output Terminal
Outputs video signals.

- (11) Setting switch**
- **MIC/LINE (default: LINE)**
Selects either line level (7) or microphone level (9) for audio signal input.
 - **PHANTOM (default: OFF)**
Sets whether to supply the 9 V phantom power supply to the microphone input terminal.
 - **AUDIO ADJ (default: OFF)**
Used when adjusting the audio/microphone level.
 - **NC (default: OFF)**
This terminal is not used.

(12) 12 V DC Output Terminal (2P)
Outputs 12 V DC power. (Maximum 0.2 A)
Connect TOA's remote controllers to this terminal.

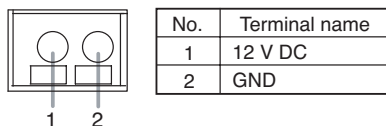

(13) 24 V AC/24 V DC Input Terminal (3P)
Receives 24 V AC or 24 V DC power. Do not use this terminal when a PoE-compatible hub is used for connection.

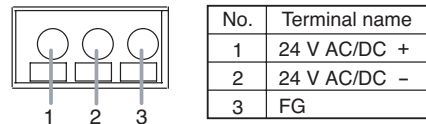

(14) Audio Output Terminal (-10 dB, low impedance, unbalanced type)
Outputs audio signals received via a network.

- (15) Contact Input and Output Terminals**
- **CONTACT IN (3P)** : Contact input terminal (2 channels)
 - **CONTACT OUT (3P)**: Contact output terminal (2 channels)

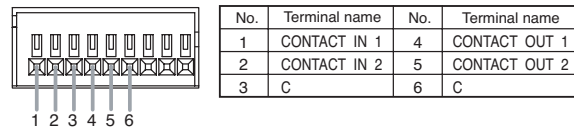

(16) RS-485 Terminal (3P)
Controls the remote controllers and other external connected devices.

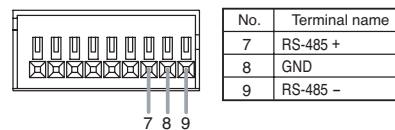

(17) RS-232C
Connect this port to the RS-232C terminal of a PC when controlling other devices via a network.

8. CONNECTIONS

8.1. Connection example

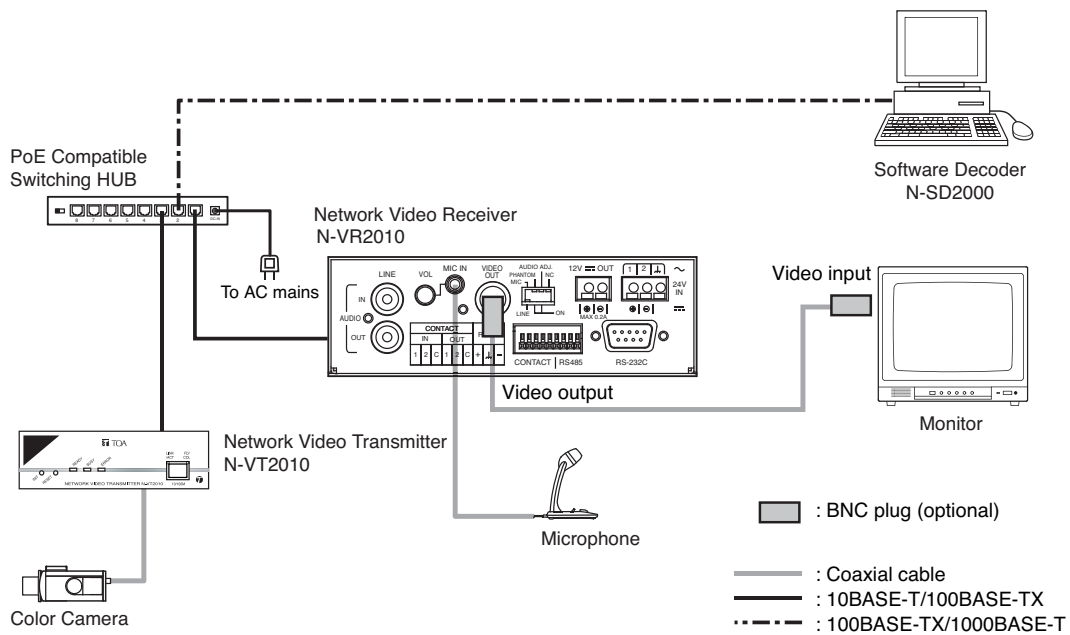

Notes

- Do not connect the 24 V AC or 24 V DC power when using a PoE-compatible hub since the power is supplied from the hub.
- Connect the 24 V AC or 24 V DC power when not using a PoE-compatible hub since no power is supplied from the hub.
- Shielded (STP) network cables must be used with this unit to ensure compliance with EMC standards.

8.2. Monitor connection

Connect the Receiver's video output terminal to the monitor's video input terminal using a coaxial cable (75Ω, BNC).

8.3. Network Connection

Connect the Receiver to a hub using a straight cable. Use a null modem cable when connecting the Receiver directly to a PC.

8.4. Microphone Connection

Connect a microphone using a mini-Jack.

When using an electret-condenser microphone, set the 9 V phantom power to ON.

8.5. Audio Input/Output connection

Connect line level audio signals using a pin jack. Audio input cannot be used simultaneously with microphone input.

8.6. Contact Input and Output Terminals

Contact Input

There are two no-voltage contact inputs for connection of sensor trigger signals, etc. For details, refer to the setup manual.

Contact Output

There are two contact outputs, allowing external connected device control and contact bridging between video network system devices. For details, refer to the setup manual.

• Applicable cable

Solid cable: AWG28 (Ø 0.32 mm) - AWG22 (Ø 0.65 mm)
Stranded cable: AWG28 (0.08 mm²) - AWG22 (0.32 mm²)

Note

Strip the cable sheath approximately 10mm, then insert the cable while pushing down on the terminal button with a screwdriver.

8.7. Serial Port

[RS-232C]

Use a null modem cable such as the YR-S2320 when connecting control terminals of the remote controller to this terminal. No RS-232C connector plug is supplied with the unit.

- RS-232C Connector D-sub 9P

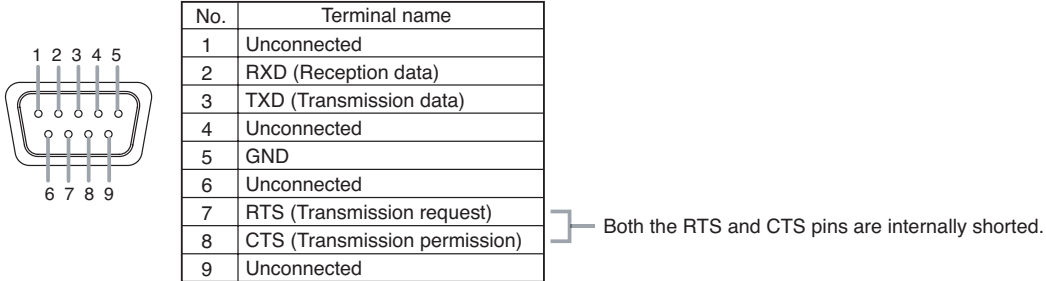

[RS-485]

Connect the control terminal of the remote controller to this terminal.

- **Applicable cable**

Solid cable: AWG28 (Ø 0.32 mm) - AWG22 (Ø 0.65 mm)
 Stranded cable: AWG28 (0.08 mm²) - AWG22 (0.32 mm²)

Note

Strip the cable sheath approximately 10mm, then insert the cable while pushing down on the terminal button with a screwdriver.

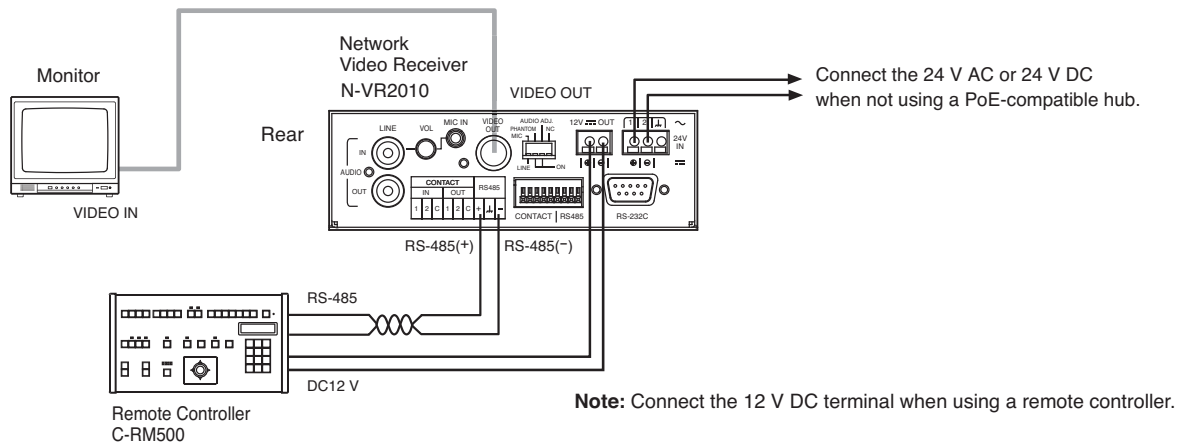

8.8. DIP Switch Setting

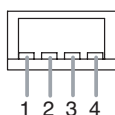

No.	Terminal name
1	MIC/ LINE
2	PHANTOM
3	AUDIO ADJ
4	NC

- 1: Selects either microphone level signal or line level signal as the audio input. Set to "MIC" when connecting a microphone, and to "LINE" when connecting other devices. ("LINE" is the default.)
- 2: Supply voltage is 9 V DC.
When supplying the phantom power to the device connected to the audio input terminal, set the MIC/LINE switch to MIC, then set this switch 2 to ON. ("OFF" is the default.)
- 3: Used for audio adjustment.
When adjusting, set this switch to ON and restart the Receiver. When the adjustment is complete, set this switch to OFF and restart the Receiver. Audio signals from the audio input and microphone can be output through the audio output terminal and monitored. ("OFF" is the default.)
- 4: This switch is not used.

9. SETTING INITIALIZATION

Returns the set contents to default conditions.

1. Either press the Reset key or switch on the power again while holding down the INIT key.
2. Continue to press the INIT key until the Ready indicator has switched from flashing to steady-on mode.

10. TROUBLESHOOTING

Symptom	Possible Cause	Remedy
Receiver does not start. (Ready LED does not light.)	Power is not supplied. [When using a PoE-compatible hub for power supply] <ul style="list-style-type: none"> • Receiver not connected to the PoE-compatible hub. • PoE-compatible hub's PoE function is not made valid. • Receiver is connected to the PoE-compatible hub's port not supporting PoE. • Power requirement exceeds the PoE-compatible hub's supply capability. [When using 24V AC or 24V DC for power supply] <ul style="list-style-type: none"> • Incorrect terminal connections. 	Supply power independently to the Receiver.
LINK/ACT LED does not light.	Cable is not correctly connected to the Receiver's network terminal.	Confirm that the cable type (category, null modem or straight) is appropriate for the connected port, then connect correctly.

11. SPECIFICATIONS

[N-VR2010 CU]

* 0 dB = 1V

Power Source	24 V AC, 50/60 Hz or 24 V DC or PoE (IEEE802.3af)
Power Consumption	10 W: at 24 V AC (9 W: PoE, 400 mA: 24 V DC)
Power Terminal	Screwless connector (Solid cable: \varnothing 0.4 – \varnothing 1.2 mm (AWG 26 – 16) Stranded cable: 0.3 – 1.25 mm ² (AWG 22 – 16))
Power Output	12 V DC, max. 0.2 A, screwless connector
Video Output	1 channel, VBS 1.0 V(p-p), 75 Ω , BNC jack, NTSC
Audio Input	1 channel, unbalanced, LINE/MIC changeable, volume adjustable LINE: – 10 dB*, 10 k Ω , RCA pin jack MIC: – 60 dB*, 2.2 k Ω , mini-jack, volume adjustable phantom power supply (9 V, can be set with the switch)
Audio Output	1 channel, – 10 dB*, low impedance, unbalanced, RCA pin jack
Audio Frequency Response	50 to 14,000 Hz (when the sampling frequency is 32 kHz)
Contact Input	2 channel, no-voltage contact input, open voltage: 3 V DC, short-circuit current : Under 10 mA, loop resistance: Under 200 Ω , screwless connector
Contact Output	2 channel, open collector output, withstand voltage: 30 V DC, control current: 50 mA, screwless connector
Serial Port	RS-232C: D-sub connector (9 pins, male), RS-485: screwless connector
Network	
Network I/F	10BASE-T/100BASE-TX, Auto-Nego/Manual: RJ45 connector
Network Protocol	TCP, UDP, SIP, RTP, IGMP, HTTP, ARP, DHCP, DNS, SNTP
Video Compression/Resolution	MPEG-4: D1 (720 x 480), Half D1 (720 x 240), QVGA (320 x 240)
Frame Rate	MPEG-4: D1 max. 30 fps
Audio Compression/Decompression	Sub-band ADPCM, PCM (non-compression)
Audio Sampling Frequency	8 kHz, 32 kHz
Image Transfer Rate	MPEG-4: max. 4 Mbps
Other Function	Password authentication
Operating Temperature	0°C to +50°C (32°F to 122°F)
Operating Humidity	Under 90% RH (no condensation)
Finish	Case: Surface-treated steel plate, silver, paint
Dimensions	136 (W) x 44 (H) x 127.9 (D) mm (5.35" x 1.73" x 5.04")
Weight	700 g (1.54 lb)

Note: The design and specifications are subject to change without notice for improvement.

[N-VR2010 PL]

* 0 dB = 1V

Power Source	24 V AC, 50/60 Hz or 24 V DC or PoE (IEEE802.3af)
Power Consumption	10 W: at 24 V AC (9 W: PoE, 400 mA: 24 V DC)
Power Terminal	Screwless connector (Solid cable: \varnothing 0.4 – \varnothing 1.2 mm (AWG 26 – 16) Stranded cable: 0.3 – 1.25 mm ² (AWG 22 – 16))
Power Output	12 V DC, max. 0.2 A, screwless connector
Video Output	1 channel, VBS 1.0 V(p-p), 75 Ω , BNC jack, PAL
Audio Input	1 channel, unbalanced, LINE/MIC changeable, volume adjustable LINE: – 10 dB*, 10 k Ω , RCA pin jack MIC: – 60 dB*, 2.2 k Ω , mini-jack, volume adjustable phantom power supply (9 V, can be set with the switch)
Audio Output	1 channel, – 10 dB*, low impedance, unbalanced, RCA pin jack
Audio Frequency Response	50 to 14,000 Hz (when the sampling frequency is 32 kHz)
Contact Input	2 channel, no-voltage contact input, open voltage: 3 V DC, short-circuit current : Under 10 mA, loop resistance: Under 200 Ω , screwless connector
Contact Output	2 channel, open collector output, withstand voltage: 30 V DC, control current: 50 mA, screwless connector
Serial Port	RS-232C: D-sub connector (9 pins, male), RS-485: screwless connector
Network	
Network I/F	10BASE-T/100BASE-TX, Auto-Nego/Manual: RJ45 connector
Network Protocol	TCP, UDP, SIP, RTP, IGMP, HTTP, ARP, DHCP, DNS, SNTP
Video Compression/Resolution	MPEG-4: D1 (720 x 576), Half D1 (720 x 288), CIF (352 x 288)
Frame Rate	MPEG-4: D1 max. 25 fps
Audio Compression/Decompression	Sub-band ADPCM, PCM (non-compression)
Audio Sampling Frequency	8 kHz, 32 kHz
Image Transfer Rate	MPEG-4: max. 4 Mbps
Other Function	Password authentication
Operating Temperature	0°C to +50°C (32°F to 122°F)
Operating Humidity	Under 90% RH (no condensation)
Finish	Case: Surface-treated steel plate, silver, paint
Dimensions	136 (W) x 44 (H) x 127.9 (D) mm (5.35" x 1.73" x 5.04")
Weight	700 g (1.54 lb)

Note: The design and specifications are subject to change without notice for improvement.



TOA Corporation

URL: <http://www.toa.jp/>

133-22-050-80