



PA100/PA101/PA102/ SPA102 Pole Mount Adapters



C250M-E (12/05)

Important Safety Instructions

Prior to installation and use of this product, the following WARNINGS should be observed.

1. Read these instructions.
2. Keep these instructions.
3. Heed all warnings.
4. Follow all instructions.
5. Only use attachments/accessories specified by the manufacturer.
6. Use only with the cart, stand, tripod, bracket, or table specified by the manufacturer, or sold with the apparatus. When a cart is used, use caution when moving the cart/apparatus combination to avoid injury from tip-over.
7. Installation should be done only by qualified personnel and conform to all local codes.
8. Unless the unit is specifically marked as a NEMA Type 3, 3R, 3S, 4, 4X, 6, or 6P enclosure, it is designed for indoor use only and it must not be installed where exposed to rain and moisture.
9. Use only installation methods and materials capable of supporting four times the maximum specified load.
10. Use stainless steel hardware to fasten the mount to outdoor surfaces.
11. **CAUTION:** These servicing instructions are for use by qualified service personnel only. To reduce the risk of electric shock do not perform any servicing other than contained in the operating instructions unless you are qualified to do so.

Please thoroughly familiarize yourself with the information in this manual prior to installation and operation.

Description

The PA100/PA101/PA102 pole mount adapters are designed to permit the use of standard wall mounts when installation of CCTV equipment is required on a pole. A Coaxitron® outdoor receiver or WLVEH enclosure can also be mounted to a PA102 when used with the PA9000 adapter. The SPA102 pole mount adapter is used in conjunction with the PA102 and ST1 support strut in installations requiring additional support for the WM2000 wall mount. The PA102, when used with the SPA102 and ST1, will support loads up to 150 pounds (68 kg).

Pole mount adapters are available to mount a variety of wall mounts on poles. All pole mount adapters are supplied with stainless steel straps for fastening the adapters to poles. Stainless steel hardware also is provided for attaching mounts to the adapters. Lightweight, rugged, and easy to install, the pole mount adapters are constructed of aluminum and have a gray polyester powder coat finish.

MODELS

PA100	Pole mount adapter for use with the EM22 mount. Mounts on poles having 1.5-inch (3.81 cm) to 8-inch (20.32 cm) diameters.
PA101	Pole mount adapter for use with the CM1450, EM1400, EM1450, PM14, and MM1000 mounts. Mounts on poles having 3-inch (7.62 cm) to 8-inch (20.32 cm) diameters.
PA102	Pole mount adapter for use with the WM2000 wall mount. Mounts on poles having 3-inch (7.62 cm) to 8-inch (20.32 cm) diameters. A Coaxitron outdoor receiver or WLVEH enclosure can be mounted to a PA102 when used with the PA9000 adapter.
SPA102	Pole mount adapter for use with the ST1 support strut in installations requiring additional pole mount support for the WM2000 wall mount. Mounts on poles having 3-inch (7.62 cm) to 8-inch (20.32 cm) diameters.

Installation

1. Position the pole mount adapter on the pole and attach it to the pole with the stainless steel straps provided. Tighten the strap screws securely.
2. Attach your mount to the pole mount adapter with the provided nuts and washers and securely tighten.
3. If you are using the WM2000 wall mount and require an ST1 support strut for additional support, install an SPA102 pole mount adapter. Measure 14 inches (36 cm) down from the bottom of the WM2000 and mark the pole. Center the SPA102 on the pole at the mark and attach the SPA102 to the pole with the stainless steel straps provided. Tighten the strap screws securely. Attach the support strut wall swivel to the SPA102 with the provided nuts and washers and securely tighten. Attach the ST1 clamp swivel to the WM2000 with the stainless steel clamp (supplied) and securely tighten.

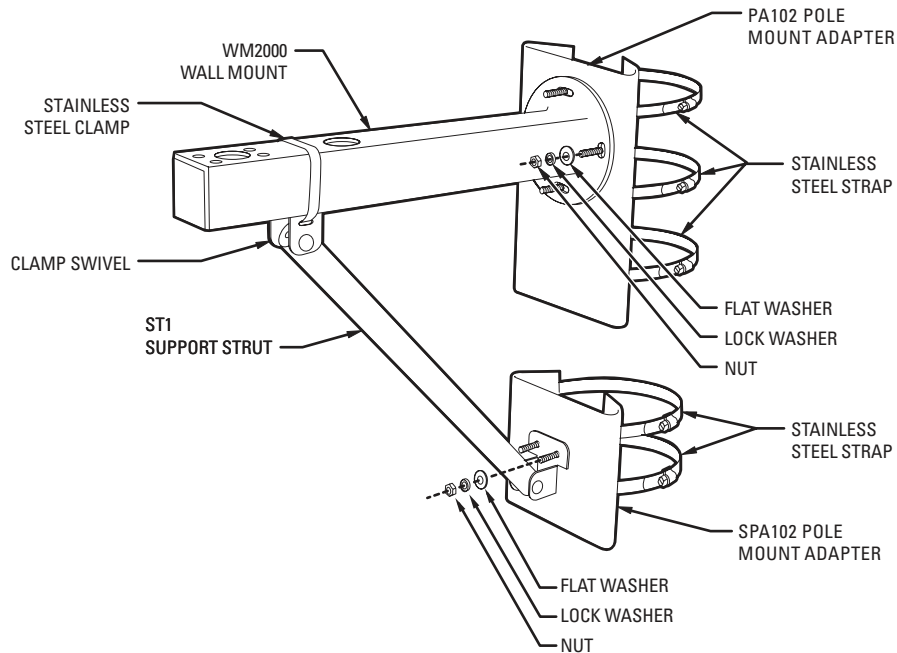

Figure 1. Typical Pole Mount Adapter Installation

Specifications

Construction	Aluminum
Finish	Gray polyester powder coat
Dimensions	
PA100	8.00" H x 3.00" W (20.32 x 7.62 cm)
PA101	5.00" H x 4.00" W (12.70 x 10.16 cm)
PA102	12.78" H x 7.00" W (32.45 x 17.78 cm)
SPA102	6.50" H x 7.00" W (16.51 x 17.78 cm)
Weight	
PA100	0.9 lb (0.4 kg)
PA101	0.9 lb (0.4 kg)
PA102	3.4 lb (1.5 kg)
SPA102	1.8 lb (0.8 kg)

(Design and product specifications subject to change without notice.)

PRODUCT WARRANTY AND RETURN INFORMATION

WARRANTY

Pelco will repair or replace, without charge, any merchandise proved defective in material or workmanship **for a period of one year** after the date of shipment.

Exceptions to this warranty are as noted below:

- Five years on FT/FR8000 Series fiber optic products.
- Three years on Genex® Series products (multiplexers, server, and keyboard).
- Three years on Camclosure® and fixed camera models, except the CC3701H-2, CC3701H-2X, CC3751H-2, CC3651H-2X, MC3651H-2, and MC3651H-2X camera models, which have a five-year warranty.
- Three years on PMCL 200/300/400 Series LCD monitors.
- Two years on standard motorized or fixed focal length lenses.
- Two years on Legacy®, CM6700/CM6800/CM9700 Series matrix, and DF5/DF8 Series fixed dome products.
- Two years on Spectra®, Esprit®, ExSite™, and PS20 scanners, including when used in continuous motion applications.
- Two years on Esprit® and WW5700 Series window wiper (excluding wiper blades).
- Two years (except lamp and color wheel) on Digital Light Processing (DLP®) displays. The lamp and color wheel will be covered for a period of 90 days. The air filter is not covered under warranty.
- Eighteen months on DX Series digital video recorders, NVR300 Series network video recorders, Endura™ Series distributed network-based video products, and TW3000 Series twisted pair transmission products.
- One year (except video heads) on video cassette recorders (VCRs). Video heads will be covered for a period of six months.
- Six months on all pan and tilts, scanners or preset lenses used in continuous motion applications (that is, preset scan, tour and auto scan modes).

Pelco will warrant all replacement parts and repairs for 90 days from the date of Pelco shipment. All goods requiring warranty repair shall be sent freight prepaid to Pelco, Clovis, California. Repairs made necessary by reason of misuse, alteration, normal wear, or accident are not covered under this warranty.

Pelco assumes no risk and shall be subject to no liability for damages or loss resulting from the specific use or application made of the Products. Pelco's liability for any claim, whether based on breach of contract, negligence, infringement of any rights of any party or product liability, relating to the Products shall not exceed the price paid by the Dealer to Pelco for such Products. In no event will Pelco be liable for any special, incidental or consequential damages (including loss of use, loss of profit and claims of third parties) however caused, whether by the negligence of Pelco or otherwise.

The above warranty provides the Dealer with specific legal rights. The Dealer may also have additional rights, which are subject to variation from state to state.

If a warranty repair is required, the Dealer must contact Pelco at (800) 289-9100 or (559) 292-1981 to obtain a Repair Authorization number (RA), and provide the following information:

1. Model and serial number
2. Date of shipment, P.O. number, Sales Order number, or Pelco invoice number
3. Details of the defect or problem

If there is a dispute regarding the warranty of a product which does not fall under the warranty conditions stated above, please include a written explanation with the product when returned.

Method of return shipment shall be the same or equal to the method by which the item was received by Pelco.

RETURNS

In order to expedite parts returned to the factory for repair or credit, please call the factory at (800) 289-9100 or (559) 292-1981 to obtain an authorization number (CA number if returned for credit, and RA number if returned for repair).

All merchandise returned for credit may be subject to a 20% restocking and refurbishing charge.

Goods returned for repair or credit should be clearly identified with the assigned CA or RA number and freight should be prepaid. Ship to the appropriate address below.

If you are located within the continental U.S., Alaska, Hawaii or Puerto Rico, send goods to:

Service Department
Pelco
3500 Pelco Way
Clovis, CA 93612-5699

If you are located outside the continental U.S., Alaska, Hawaii or Puerto Rico and are instructed to return goods to the USA, you may do one of the following:

If the goods are to be sent by a COURIER SERVICE, send the goods to:

Pelco
3500 Pelco Way
Clovis, CA 93612-5699 USA

If the goods are to be sent by a FREIGHT FORWARDER, send the goods to:

Pelco c/o Expeditors
473 Eccles Avenue
South San Francisco, CA 94080 USA
Phone: 650-737-1700
Fax: 650-737-0933

REVISION HISTORY

Manual #	Date	Comments
C250M-D	5/99	Revised manual to new format. Revised installation instructions. Added Figure 1. Revised specifications.
C250M-E	12/05	Revised to new format. Updated pole diameter for stainless steel mounting straps per CAR 05-0928.

Pelco, the Pelco logo, Camclosure, Coaxitron, Esprit, Genex, Legacy, and Spectra are registered trademarks of Pelco.
Endura and ExSite are trademarks of Pelco.
DLP is a registered trademark of Texas Instruments, Inc.

©Copyright 2005, Pelco. All rights reserved.

Worldwide Headquarters • 3500 Pelco Way • Clovis, California 93612 USA • www.pelco.com
USA & Canada • Tel: 800/289-9100 • Fax: 800/289-9150
International • Tel: 1-559/292-1981 • Fax: 1-559/348-1120