



**FT8308/FR8308  
Fiber Transmitter  
and Receiver**



**Eight-Channel Digitally Encoded Video**

**C1647M (3/05)**

# Contents

---

Important Safety Instructions .....	3
Regulatory Notices .....	5
Product Overview .....	6
Description .....	6
Models .....	7
Optional Accessories .....	7
Front Panel .....	8
Front Panel - FT8308 Transmitter .....	8
Front Panel - FR8308 Receiver .....	9
Rear Panel .....	10
Rear Panel - FT8308 Transmitter .....	10
Rear Panel - FR8308 Receiver .....	11
Installation .....	12
Package Contents .....	12
Mounting .....	12
Mounting the Transmitter/Receiver into a Rack .....	12
Mounting the Transmitter/Receiver to a Wall .....	13
Connections .....	15
Troubleshooting .....	16
Specifications .....	18

## List of Illustrations

1	Eight-Channel Video FT8308 Transmitter and FR8308 Receiver .....	6
2	Front Panel of FT8308 Transmitter .....	8
3	Front Panel of FR8308 Receiver .....	9
4	Rear Panel of FT8308 Transmitter .....	10
5	Rear Panel of FR8308 Receiver .....	11
6	Mounting the FT8308 Transmitter/FR8308 Receiver Using the Wall Clip .....	14
7	FT8308 Transmitter/FR8308 Receiver Connections .....	15

## List of Tables

A	Troubleshooting with Front-Panel Indicators .....	16
---	---	----

# Important Safety Instructions

---

1. Read these instructions.
2. Keep these instructions.
3. Heed all warnings.
4. Follow all instructions.
5. Do not use this apparatus near water.
6. Clean only with dry cloth.
7. Do not block any ventilation openings. Install in accordance with the manufacturer's instructions.
8. Do not install near any heat sources such as radiators, heat registers, stoves, or other apparatus (including amplifiers) that produce heat.
9. Do not defeat the safety purpose of the polarized or grounding-type plug. A polarized plug has two blades with one wider than the other. A grounding plug has two blades and a third grounding prong. The wide blade or the third prong are provided for your safety. If the provided plug does not fit into your outlet consult an electrician for replacement of the obsolete outlet.
10. Protect the power cord from being walked on or pinched particularly at plugs, convenience receptacles, and the points where they exit from the apparatus.
11. Only use attachments/accessories specified by the manufacturer.
12. Use only with the cart, stand, tripod, bracket, or table specified by the manufacturer, or sold with the apparatus. When a cart is used, use caution when moving the cart/apparatus combination to avoid injury from tip-over.
13. Unplug this apparatus during lightning storms or when unused for long periods of time.
14. Refer all servicing to qualified service personnel. Servicing is required when the apparatus has been damaged in any way, such as power-supply cord or plug is damaged, liquid has been spilled or objects have fallen into the apparatus, the apparatus has been exposed to rain or moisture, does not operate normally, or has been dropped.
15. Apparatus shall not be exposed to dripping or splashing and that no objects filled with liquids, such as vases shall be placed on the apparatus.
16. **WARNING:** To reduce the risk of fire or electric shock, do not expose this apparatus to rain or moisture.
17. Installation should be done only by qualified personnel and conform to all local codes.
18. Unless the unit is specifically marked as a NEMA Type 3, 3R, 3S, 4, 4X, 6, or 6P enclosure, it is designed for indoor use only and it must not be installed where exposed to rain and moisture.
19. Use only installation methods and materials capable of supporting four times the maximum specified load.

**CAUTION:** These servicing instructions are for use by qualified service personnel only. To reduce the risk of electric shock do not perform any servicing other than that contained in the operating instructions unless you are qualified to do so.

The product and/or manual may bear the following marks:

 This symbol indicates that dangerous voltage constituting a risk of electric shock is present within this unit.

 This symbol indicates that there are important operating and maintenance instructions in the literature accompanying this unit.

<b>CAUTION:</b>
RISK OF ELECTRIC SHOCK. DO NOT OPEN.

# Regulatory Notices

---

This device complies with Part 15 of the FCC Rules. Operation is subject to the following two conditions: (1) this device may not cause harmful interference, and (2) this device must accept any interference received, including interference that may cause undesired operation.

## **RADIO AND TELEVISION INTERFERENCE**

This equipment has been tested and found to comply with the limits of a Class A digital device, pursuant to Part 15 of the FCC Rules. These limits are designed to provide reasonable protection against harmful interference when the equipment is operated in a commercial environment. This equipment generates, uses, and can radiate radio frequency energy and, if not installed and used in accordance with the instruction manual, may cause harmful interference to radio communications. Operation of this equipment in a residential area is likely to cause harmful interference in which case the user will be required to correct the interference at his own expense.

Changes and Modifications not expressly approved by the manufacturer or registrant of this equipment can void your authority to operate this equipment under Federal Communications Commission's rules.

This Class A digital apparatus complies with Canadian ICES-003.

Cet appareil numérique de la classe A est conforme à la norme NMB-003 du Canada.

# Product Overview

---

## DESCRIPTION

The FT8308/FR8308 fiber transmitter and receiver provide the ability to transmit up to eight composite video channels over one optical fiber (refer to Figure 1).

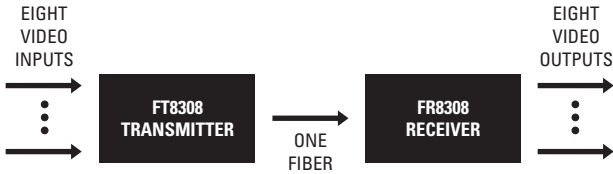

**Figure 1.** Eight-Channel Video FT8308 Transmitter and FR8308 Receiver

Features of the FT8308/FR8308 fiber optic transmission system include the following:

- 8-bit digitally encoded video for high-quality multi-channel video transmission over a single fiber
- Multimode fiber support for distances up to 1 km (0.6 mi)
- Single-mode fiber support for distances up to 30 km (18.6 mi)
- Exceeds all requirements for the RS-250C Medium-Haul Transmission specification
- Compatible with NTSC, PAL, and SECAM video standards
- No performance adjustments required
- 12 VDC or 24 VAC power supply
- Standalone and rack-mountable modular design
- LED indicators for monitoring of signal status and operating power



**NOTE:** The FT8308 transmitter/FR8308 receiver is a Class 1 laser product that complies with FDA radiation performance standard 21CFR Subchapter J and with IEC 60825-1 Edition 1.2, 2001-08.

## MODELS

The FT8308/FR8308 fiber transmitter and receiver consist of the following series of models:

### Multimode Models:

FT8308MSTR	Eight-channel fiber optic video transmitter; multimode, ST connector
FR8308MSTR	Eight-channel fiber optic video receiver; multimode, ST connector

### Single-Mode Models:

FT8308SSTR	Eight-channel fiber optic video transmitter; single-mode, ST connector
FR8308SSTR	Eight-channel fiber optic video receiver; single-mode, ST connector
FT8308SFCR	Eight-channel fiber optic video transmitter; single-mode, FC connector
FR8308SFCR	Eight-channel fiber optic video receiver; single-mode, FC connector

## OPTIONAL ACCESSORIES

The following optional accessories are available:

WM5002-3U	Wall mount base kit for double-width module
WM5002-3UEXP	Wall mount expansion kit for double-width module
RK5000-3U	19-inch rack mount chassis for 14 slots (no power), 3 RUs
RK5000PS-3U	19-inch rack mount chassis for 12 slots with power, 3 RUs
EPS5000-120	External/redundant power supply, 1 RU, 120 W x 2
RK5001B-3U	Blank filler panel, single width
RK5002B-3U	Blank filler panel, double width
RK5002-1UEXP	Adapter kit that allows a 3 RU double-width fiber optic module to be used in RK5000PS-5U rack mount chassis

## FRONT PANEL

The front panel of the FT8308 transmitter and the FR8308 receiver provides LED indicators that allow you to monitor signal status and operating power. The following sections provide a view of the front panel of the FT8308 transmitter and the FR8308 receiver.

### FRONT PANEL - FT8308 TRANSMITTER

Figure 2 illustrates the front panel of the FT8308 transmitter.

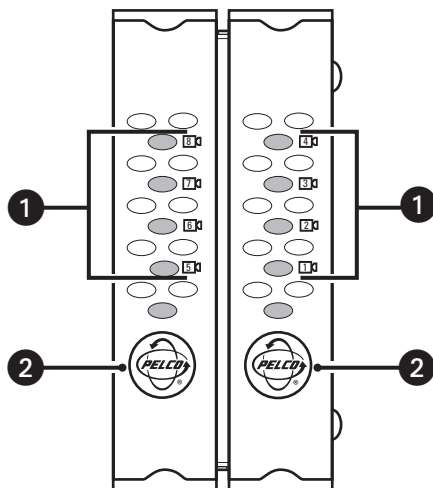

**Figure 2.** Front Panel of FT8308 Transmitter

- 1 VIDEO PRESENT LEDs (1-8)
- 2 POWER LED (Pelco badge)

For detailed information about the front-panel indicators, refer to the *Troubleshooting* section.



## FRONT PANEL - FR8308 RECEIVER

Figure 3 illustrates the front panel of the FR8308 receiver.

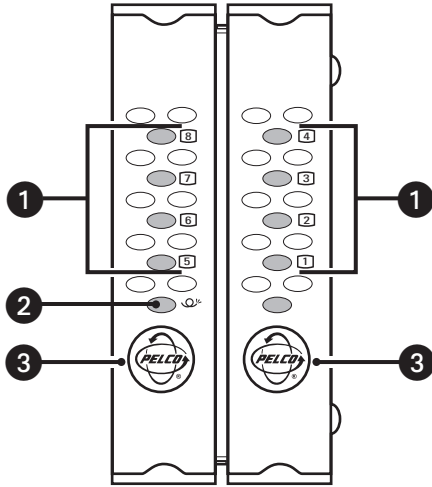

**Figure 3.** Front Panel of FR8308 Receiver

- ① VIDEO PRESENT LEDs (1-8)
- ② CARRIER DETECT LED
- ③ POWER LED (Pelco badge)

For detailed information about the front-panel indicators, refer to the *Troubleshooting* section.

## REAR PANEL

Connections to the FT8308 transmitter and the FR8308 receiver are made to the rear panel of the modules. The following sections provide a view of the rear panel of the FT8308 transmitter and the FR8308 receiver.

### REAR PANEL - FT8308 TRANSMITTER

Figure 4 illustrates the rear panel of the FT8308 transmitter.

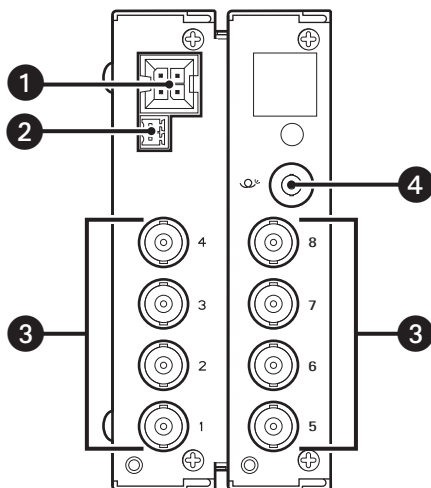

**Figure 4.** Rear Panel of FT8308 Transmitter

- ❶ RACK POWER/ALARM CONNECTOR, 4-pin connector for power/alarm connection of rack-mounted module
- ❷ STANDALONE POWER CONNECTOR, 2-pin connector for power connection of standalone module; removable mating connector with screw terminals (not shown)
- ❸ VIDEO IN CONNECTORS (1-8), 75-ohm BNC analog video input
- ❹ FIBER OPTIC CONNECTOR, ST or FC (dependent on FT8308 model)

For additional information about rear-panel connections, refer to the *Installation* section.

## REAR PANEL - FR8308 RECEIVER

Figure 5 illustrates the rear panel of the FR8308 receiver.

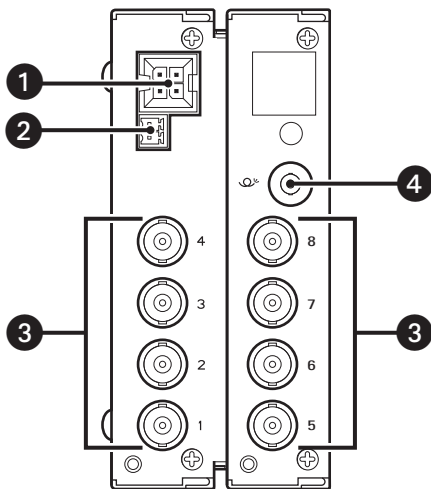

**Figure 5.** Rear Panel of FR8308 Receiver

- 1 RACK POWER/ALARM CONNECTOR, 4-pin connector for power/alarm connection of rack-mounted module
- 2 STANDALONE POWER CONNECTOR, 2-pin connector for power connection of standalone module; removable mating connector with screw terminals (not shown)
- 3 VIDEO OUT CONNECTORS (1-8), 75-ohm BNC analog video output
- 4 FIBER OPTIC CONNECTOR, ST or FC (dependent on FR8308 model)

For additional information about rear-panel connections, refer to the *Installation* section.

# Installation

---

## PACKAGE CONTENTS

The following items are supplied:

- **With the FT8308 transmitter:**
  - 1 Regulated switching power supply with four plug adapters (North American, Australian, U.K., and European configurations); 100-240 VAC input, 12 VDC input
  - 1 Wall clip with two 4-40 x .250-inch Phillips pan head screws with lock washers (for attachment of single module to wall)
  - 1 FT8308/FR8308 Fiber Transmitter and Receiver Installation manual (this manual)
- **With the FR8308 receiver:**
  - 1 Regulated switching power supply with four plug adapters (North American, Australian, U.K., and European configurations); 100-240 VAC input, 12 VDC input
  - 1 Wall clip with two 4-40 x .250-inch Phillips pan head screws with lock washers (for attachment of single module to wall)
  - 1 FT8308/FR8308 Fiber Transmitter and Receiver Installation manual (this manual)

## MOUNTING

The FT8308 transmitter/FR8308 receiver can be mounted into a rack or can be used as a standalone module. As a standalone module, the unit can be placed on a desktop or can be mounted to a wall.

### MOUNTING THE TRANSMITTER/RECEIVER INTO A RACK

The FT8308 transmitter/FR8308 receiver can be installed into an RK5000 Series rack mount chassis, which can be mounted into an industry-standard 19-inch (48.26 cm) equipment rack. The RK5000 Series rack mount chassis includes the following models:

- **RK5000PS-3U and RK5000-3U:** Designed to accommodate fiber optic modules as follows:
  - The RK5000PS-3U rack mount chassis provides 12 single-width module slots and a power supply.
  - The RK5000-3U rack mount chassis provides 14 single-width module slots (a power supply is not included). Power to the modules can be supplied using the optional external power supply (EPS5000-120).

For additional information, refer to the RK5000PS-3U/RK5000-3U Fiber Rack Mount Chassis Installation manual.

- **RK5000PS-5U:** Designed to accommodate Endura™ modules but can also accommodate fiber optic modules with the use of the appropriate adapter kit. The RK5002-1UEXP adapter kit is required for installation of the FT8308 transmitter/FR8308 receiver into the RK5000PS-5U chassis.

For information about the RK5000PS-5U chassis, refer to the RK5000PS-5U Rack Mount Chassis Installation manual.



**NOTE:** The FT8308 transmitter/FR8308 receiver is a double-width fiber optic module that occupies two slots in the RK5000PS-3U, RK5000-3U, and RK5000PS-5U chassis.

## MOUNTING THE TRANSMITTER/RECEIVER TO A WALL

The FT8308 transmitter/FR8308 receiver can be mounted to a wall in the following ways:

- Using the supplied wall clip for attachment of a single module to a wall. For installation instructions, refer to the *Mounting the Transmitter/Receiver Using the Wall Clip* section below.
- Using the optional WM5002 wall mount kits, which are designed for mounting of double-width fiber optic modules. The WM5002-3U base kit allows attachment of a single module to the wall. The WM5002-3UEXP expansion kit allows attachment of an additional module to the wall. It is recommended that a maximum of one expansion kit be used with the base kit, allowing a maximum of two double-width modules to be attached to the wall.



**NOTE:** The WM5002 wall mount kits can be used with the WM5001 wall mount kits, which are designed for mounting of single-width fiber optic modules. If mounting a mix of single-width and double-width modules is desired, it is recommended that a maximum of two single-width modules and one double-width module be mounted in combination with one another.

For mounting instructions using the wall mount kits, refer to the WM5000 Series Wall Mount Kit Installation manual.

### Mounting the Transmitter/Receiver Using the Wall Clip



**NOTE:** Before mounting the FT8308 transmitter/FR8308 receiver to a wall, ensure that there is adequate space at both ends for viewing the front-panel LEDs and for making the various rear-panel cable connections.

To attach the FT8308 transmitter/FR8308 receiver to a wall using the supplied wall clip, refer to Figure 6 and do the following:

1. Using the two vertical or horizontal wall-mounting holes, attach the wall clip to a wall using two screws (not provided).
2. Slide the module into the clip until the two holes on the bottom of the module align with the two holes on the lower flange of the clip.
3. Attach the module to the clip using the two Phillips pan head screws provided for the clip.

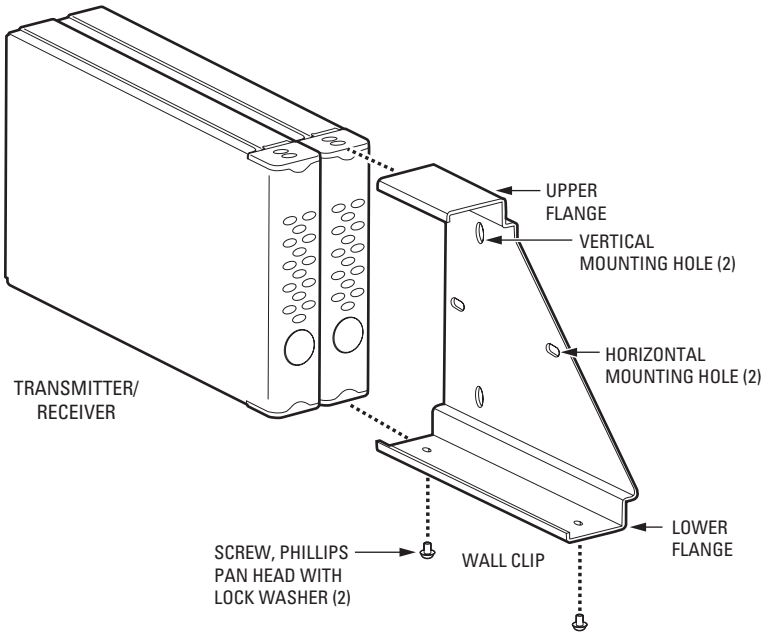

**Figure 6.** Mounting the FT8308 Transmitter/FR8308 Receiver Using the Wall Clip

# CONNECTIONS

Connections to the FT8308 transmitter and the FR8308 receiver are made on the rear panel of the modules and consist of the following:

- Power connection



**NOTE:** A 12 VDC or 24 VAC power supply can be used to power the transmitter/receiver when used as a standalone module. A 12 VDC power supply is provided. If a 24 VAC power supply is used, the power supply must be a Listed Direct Plug-In Power Unit marked as Class 2 and rated as 24 VAC, 200 mA (minimum output).

- Fiber connection
- Video input connections (transmitter only)
- Video output connections (receiver only)

Figure 7 provides an illustration of FT8308 transmitter/FR8308 receiver connections.

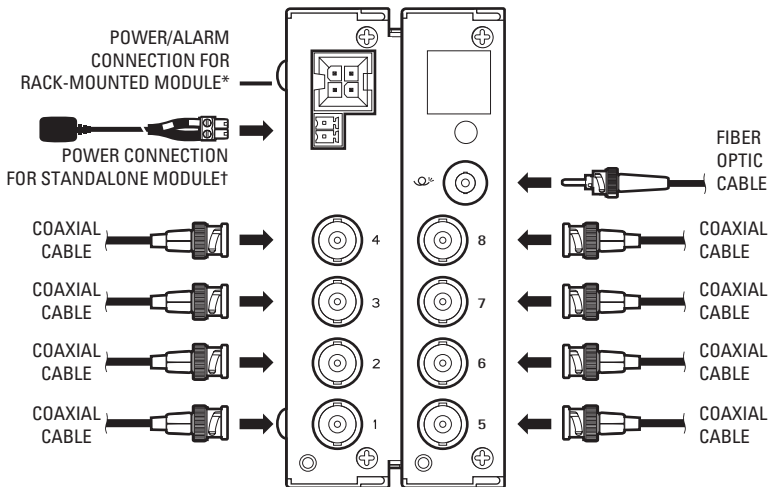

\*REFER TO THE RK5000PS-3U/RK5000-3U FIBER RACK MOUNT CHASSIS INSTALLATION MANUAL FOR INFORMATION.

†THE STRIPED WIRE OF THE SUPPLIED 12 VDC POWER SUPPLY CONNECTS TO THE PIN 1 SCREW TERMINAL (DC+) OF THE STANDALONE POWER CONNECTOR. THE OTHER WIRE CONNECTS TO THE PIN 2 SCREW TERMINAL (DC-).

**Figure 7.** FT8308 Transmitter/FR8308 Receiver Connections

# Troubleshooting

LED indicators on the front panel of the FT8308 transmitter/FR8308 receiver (refer to Figure 2 and to Figure 3, respectively) allow you to monitor signal status and operating power. Table A provides information about the front-panel indicators and associated troubleshooting guidelines.

**Table A.** Troubleshooting with Front-Panel Indicators

Indicator Color	Meaning	Possible Cause	Corrective Action
<b>Power LED (Pelco badge)</b>			
Blue Pelco logo lights.	Power is being applied to the module.	—	No action required.
Blue Pelco logo does not light.	Power is not being applied to the module.	Power connection is faulty.	Check power connection. If module is rack mounted, reseal module or power supply as necessary.
		Power supply has failed.	Replace power supply.
		Loss of power occurs due to tripped circuit breaker(s), blown fuse(s), or faulty electrical service.	Check circuit breaker(s), fuse(s), or electrical service as necessary.
<b>Video Present LED</b>			
Green	Incoming video signal is present on the channel.	—	No action required.
Red on transmitter	Incoming video signal is not present on the channel.	Video source is not powered on.	Check power connection to the video source.
		Video source is not connected to the transmitter.	Check BNC connections.
		Coaxial cable is defective.	Replace cable.

*(Continued on next page)*



**Table A.** Troubleshooting with Front-Panel Indicators (Continued)

<b>Indicator Color</b>	<b>Meaning</b>	<b>Possible Cause</b>	<b>Corrective Action</b>
<b>Video Present LED (Continued)</b>			
Red on receiver	Incoming video signal is not present on the channel.	Optical signal is not being received from the transmitter. Carrier Detect LED is also red.	Refer to the Carrier Detect LED troubleshooting section below.
		Video source is not powered on.	Check power connection to the video source.
		Video source is not connected to the transmitter.	Check BNC connections.
		Coaxial cable connected to the transmitter is defective.	Replace cable.
<b>Carrier Detect LED (Receiver Only)</b>			
Green	The optical signal is being received from the transmitter.	—	No action required.
Red	The optical signal is not being received from the transmitter.	Transmitter is not powered on.	Check power connections. Replace power supply if necessary.
		Fiber optic cable is not connected.	Check fiber optic connections.
		Fiber optic cable connectors are dirty or are damaged.	Clean, polish, or replace fiber optic cable connectors as necessary.
		Fiber optic cable is defective.	Replace cable.
		A problem exists with the optical power budget.	Verify that losses in fiber optic cable do not exceed the optical power budget specification of the fiber optic link. If the losses do exceed the optical power budget, contact Product Support.

# Specifications

## VIDEO

Number of Channels	8
Modulation Type	Pulse code modulation, 8-bit resolution
Video Input	1.0 Vp-p, 75 ohms; NTSC, PAL, and SECAM
Bandwidth	6.5 MHz
Gain	Unity
Crosstalk	-50 dB typical at 3.58 MHz
Differential Gain	<1%
Differential Phase	<1.2°
Tilt	<1%
Signal-to-Noise Ratio	>60 dB (CCIR weighted)

## GENERAL

Operating Temperature	-40° to 167°F (-40° to 75°C)
Input Power Requirements	12 VDC or 24 VAC, 460 mA
LED Indicators	
Transmitter	Power Video Present (per channel)
Receiver	Power Video Present (per channel) Carrier Detect
Dimensions	8.75" D x 2.28" W x 4.81" H (22.23 x 5.79 x 12.22 cm)
Unit Weight	2.56 lb (1.16 kg)

## MECHANICAL

Connectors	
Video	BNC (per channel)
Rack Power/Alarm	4-pin connector
Standalone Power	2-pin connector, screw terminal
Fiber Optic	ST for multimode fiber ST or FC for single-mode fiber

## OPTICAL POWER BUDGET, TRANSMISSION DISTANCE, AND LASER CLASS 1 LIMIT

Fiber	Wavelength	Optical Power Budget	Maximum Transmission Distance	Laser Class 1 Limit*
Multimode (62.5/125 μm)	1310 nm	20 dB <sup>†</sup>	1 km (0.6 mi) <sup>††</sup>	<15.6 mW
Single-mode (9/125 μm)	1310 nm	20 dB	30 km (18.6 mi) <sup>§</sup>	<15.6 mW

\* The FT8308 transmitter/FR8308 receiver is classified by the FDA as a Class 1 laser product.  
<sup>†</sup>When using 50/125 μm fiber, subtract 3 dB from the optical power budget.  
<sup>††</sup>Maximum transmission distance is limited by fiber bandwidth.  
<sup>§</sup>Maximum transmission distance is based on attenuation of 0.5 dB/km plus a 5 dB buffer for connector and splice losses.

# PRODUCT WARRANTY AND RETURN INFORMATION

## WARRANTY

Pelco will repair or replace, without charge, any merchandise proved defective in material or workmanship **for a period of one year** after the date of shipment.

Exceptions to this warranty are as noted below:

- Five years on FT/FR8000 Series fiber optic products and the following fixed camera models: CC3701H-2, CC3701H-2X, CC3751H-2, CC3651H-2X, MC3651H-2, and CC3651H-2X.
- Three years on all other fixed camera models (including Camclosure® Integrated Camera Systems) and Genex® Series (multiplexers, server, and keyboard).
- Two years on all standard motorized or fixed focal length lenses.
- Two years on Legacy®, CM6700/CM6800/CM8500/CM9500/CM9700 Matrix, DF5 and DF8 Series Fixed Dome products.
- Two years on Spectra®, Esprit®, and PS20 Scanners, including when used in continuous motion applications.
- Two years on Esprit® and WW5700 series window wiper (excluding wiper blades).
- Eighteen months on DX Series digital video recorders and NVR300 Series network video recorders.
- One year (except video heads) on video cassette recorders (VCRs). Video heads will be covered for a period of six months.
- Six months on all pan and tilts, scanners or preset lenses used in continuous motion applications (that is, preset scan, tour and auto scan modes).

Pelco will warrant all replacement parts and repairs for 90 days from the date of Pelco shipment. All goods requiring warranty repair shall be sent freight prepaid to Pelco, Clovis, California. Repairs made necessary by reason of misuse, alteration, normal wear, or accident are not covered under this warranty.

Pelco assumes no risk and shall be subject to no liability for damages or loss resulting from the specific use or application made of the Products. Pelco's liability for any claim, whether based on breach of contract, negligence, infringement of any rights of any party or product liability, relating to the Products shall not exceed the price paid by the Dealer to Pelco for such Products. In no event will Pelco be liable for any special, incidental or consequential damages (including loss of use, loss of profit and claims of third parties) however caused, whether by the negligence of Pelco or otherwise.

The above warranty provides the Dealer with specific legal rights. The Dealer may also have additional rights, which are subject to variation from state to state.

If a warranty repair is required, the Dealer must contact Pelco at (800) 289-9100 or (559) 292-1981 to obtain a Repair Authorization number (RA), and provide the following information:

1. Model and serial number
2. Date of shipment, P.O. number, Sales Order number, or Pelco invoice number
3. Details of the defect or problem

If there is a dispute regarding the warranty of a product which does not fall under the warranty conditions stated above, please include a written explanation with the product when returned.

Method of return shipment shall be the same or equal to the method by which the item was received by Pelco.

## RETURNS

In order to expedite parts returned to the factory for repair or credit, please call the factory at (800) 289-9100 or (559) 292-1981 to obtain an authorization number (CA number if returned for credit, and RA number if returned for repair).

All merchandise returned for credit may be subject to a 20% restocking and refurbishing charge.

Goods returned for repair or credit should be clearly identified with the assigned CA or RA number and freight should be prepaid. Ship to the appropriate address below.

*If you are located within the continental U.S., Alaska, Hawaii or Puerto Rico, send goods to:*

Service Department  
Pelco  
3500 Pelco Way  
Clovis, CA 93612-5699

*If you are located outside the continental U.S., Alaska, Hawaii or Puerto Rico and are instructed to return goods to the USA, you may do one of the following:*

If the goods are to be sent by a COURIER SERVICE, send the goods to:

Pelco  
3500 Pelco Way  
Clovis, CA 93612-5699 USA

If the goods are to be sent by a FREIGHT FORWARDER, send the goods to:

Pelco c/o Expeditors  
473 Eccles Avenue  
South San Francisco, CA 94080 USA  
Phone: 650-737-1700  
Fax: 650-737-0933

## REVISION HISTORY

Manual #	Date	Comments
C1647M	3/05	Original version.

Pelco, the Pelco logo, Spectra, Genex, Legacy, Esprit, and Camclosure are registered trademarks of Pelco. Endura is a trademark of Pelco. ©Copyright 2005, Pelco. All rights reserved.



Worldwide Headquarters  
3500 Pelco Way  
Clovis, California 93612 USA

USA & Canada  
Tel: 800/289-9100  
Fax: 800/289-9150  
International  
Tel: 1-559/292-1981  
Fax: 1-559/348-1120

[www.pelco.com](http://www.pelco.com)

ISO9001