



3500 Pelco Way,
Clovis, CA 93612-5699
USA

In North America & Canada:
Tel (800) 289-9100
FAX (800) 289-9150

International Customers:
Tel (1-559) 292-1981
FAX (1-559) 348-1120

www.pelco.com



C202M-B (4/99) EM1009U/EM1015U/EM1900U Enclosure Mounts

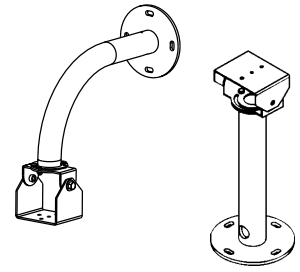

IMPORTANT SAFEGUARDS AND WARNINGS

Prior to installation and use of this product, the following WARNINGS should be observed.

1. Installation and servicing should only be done by qualified service and installation personnel.
2. Installation shall be done in accordance with all local and national electrical and mechanical codes utilizing only approved materials.
3. Use only installation methods and materials capable of supporting four times the maximum specified load.
4. Use stainless steel hardware to fasten the mount to outdoor surfaces.
5. To prevent damage from water leakage when installing a mount outdoors on a roof or wall, apply sealant around the bolt holes between the mount and mounting surface.

The product and/or manual may bear the following marks:



This symbol indicates that dangerous voltage constituting a risk of electric shock is present within this unit.



This symbol indicates that there are important operating and maintenance instructions in the literature accompanying this unit.



Please thoroughly familiarize yourself with the information in this manual prior to installation and operation.

DESCRIPTION

The EM1009U/EM1015U/EM1900U mounts are capable of supporting loads up to 40 pounds (18 kg) and are designed for ceiling, pedestal, and wall applications. These versatile mounts can be used with enclosures that have a 2-inch (5.08 cm) mounting hole pattern.

Constructed of aluminum, all three mounts feature a manually adjustable swivel head that allows 360-degree horizontal positioning of the enclosure. In addition, there is a 1-inch (2.54 cm) diameter cable feedthrough hole and openings in the top and bottom to conceal the wiring.

Models

EM1009U	Universal, medium-duty, pedestal/ceiling mount with manually adjustable swivel head. Mount extends 10.66 inches (27.08 cm) from wall or ceiling.
EM1015U	Universal, medium-duty, pedestal/ceiling mount with manually adjustable swivel head. Mount extends 16.66 inches (42.32 cm) from wall or ceiling.
EM1900U	Universal, medium-duty, 90-degree wall mount with manually adjustable swivel head. Mount extends 14.98 inches (38.05 cm) from wall or ceiling.



CAUTION: Make certain that the mounting surface is capable of supporting four times the full load of the mount, enclosure, and camera.

INSTALLATION

To attach the mount, perform the following steps:

1. Determine the location where the mount is to be installed.
2. Using the mount as a template, mark and drill holes in the mounting surface.
3. Bring the wiring in from the cable hole in the mounting plate or the side of the mount near the mounting plate and through the mount arm.
4. Attach the mount securely with four 1/4-20 fasteners (not provided) of appropriate length. When installing the mount outdoors, seal the mounting holes with an appropriate sealant. Apply the sealant around the holes between the mount and the mounting surface.
5. Attach the enclosure or camera securely with the two 1/4-20 x 0.625-inch (1.588 cm) hex bolts provided.
6. Loosen the bolts on the swivel head and position as desired. Tighten bolts and lock into place.
7. Make all necessary electrical connections to the enclosure and camera (refer to the manuals provided with the enclosure and camera.)

SERVICE MANUAL

If you need replacement parts, obtain a service manual in one of the following ways:

- Go to Pelco's web site at <ftp://www.pelco.com> and find service manual C202SM.
- Contact Pelco's Literature Department and request service manual C202SM.

SPECIFICATIONS

Construction: Aluminum

Finish: Gray polyester powder coat

Maximum Load: 40 lb (18 kg)

Pan Adjustment: 360°

Tilt Adjustment: $\pm 75^\circ$

Locking Method: 3/8-16 hex bolts

Enclosure

Mounting: Two 1/4-20 x 0.625-inch (1.588 cm) hex bolts (provided)

Suggested

Mounting Method: Secure to solid surface with four 1/4-20 fasteners (not provided)

Unit Weight

EM1009U: 1.98 lb (0.90 kg)

EM1015U: 2.43 lb (1.10 kg)

EM1900U: 2.83 lb (1.28 kg)

Dimensions: See Figure 1 and Figure 2

(Design and product specifications subject to change without notice.)

NOTE: VALUES IN PARENTHESES ARE CENTIMETERS; ALL OTHERS ARE INCHES

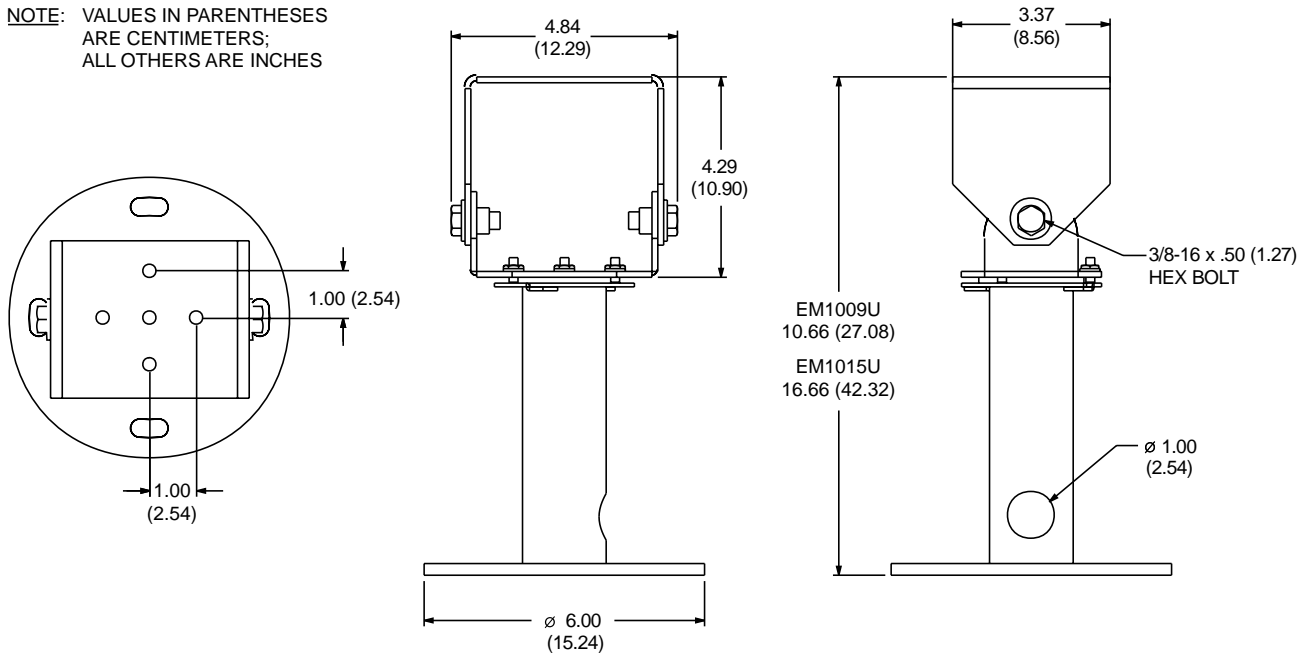
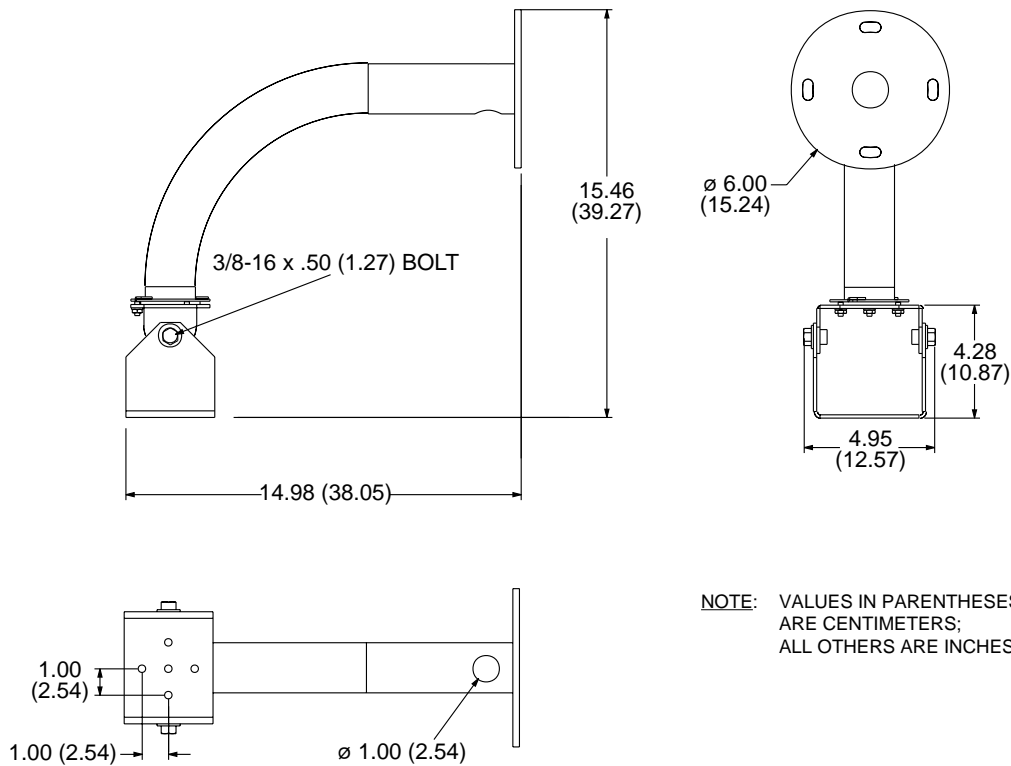

Figure 1. EM1009U/EM1015U Dimension Drawing



NOTE: VALUES IN PARENTHESES ARE CENTIMETERS; ALL OTHERS ARE INCHES

Figure 2. EM1900U Dimension Drawing

WARRANTY AND RETURN INFORMATION

WARRANTY

Pelco will repair or replace, without charge, any merchandise proved defective in material or workmanship for a period of one year after the date of shipment.

Exceptions to this warranty are as noted below:

- Five years on FT/FR8000 Series fiber optic products.
- Three years on Genex® Series products (multiplexers, server, and keyboard).
- Three years on Camclosure® and fixed camera models, except the CC3701H-2, CC3701H-2X, CC3751H-2, CC3651H-2X, MC3651H-2, and CC3651H-2X camera models, which have a five-year warranty.
- Two years on standard motorized or fixed focal length lenses.
- Two years on Legacy®, CM6700/CM6800/CM9700 Series matrix, and DF5/DF8 Series fixed dome products.
- Two years on Spectra®, Esprit®, ExSite™, and PS20 Scanners, including when used in continuous motion applications.
- Two years on Esprit™ and WW5700 Series window wiper (excluding wiper blades).
- Eighteen months on DX Series digital video recorders, NVR300 Series network video recorders, and Endura™ Series distributed network-based video products. months on DX Series digital video recorders, NVR300 Series network video recorders, Endura™ Series distributed network-based video products, and TW3000 Series twisted pair transmission products.
- One year (except video heads) on video cassette recorders (VCRs). Video heads will be covered for a period of six months.
- Six months on all pan and tilts, scanners or preset lenses used in continuous motion applications (that is, preset scan, tour and auto scan modes).

Pelco will warrant all replacement parts and repairs for 90 days from the date of Pelco shipment. All goods requiring warranty repair shall be sent freight prepaid to Pelco, Clovis, California. Repairs made necessary by reason of misuse, alteration, normal wear, or accident are not covered under this warranty.

Pelco assumes no risk and shall be subject to no liability for damages or loss resulting from the specific use or application made of the Products. Pelco's liability for any claim, whether based on breach of contract, negligence, infringement of any rights of any party or product liability, relating to the Products shall not exceed the price paid by the Dealer to Pelco for such Products. In no event will Pelco be liable for any special, incidental or consequential damages (including loss of use, loss of profit and claims of third parties) however caused, whether by the negligence of Pelco or otherwise.

The above warranty provides the Dealer with specific legal rights. The Dealer may also have additional rights, which are subject to variation from state to state.

If a warranty repair is required, the Dealer must contact Pelco at (800) 289-9100 or (559) 292-1981 to obtain a Repair Authorization number (RA), and provide the following information:

1. Model and serial number
2. Date of shipment, P.O. number, Sales Order number, or Pelco invoice number
3. Details of the defect or problem

If there is a dispute regarding the warranty of a product which does not fall under the warranty conditions stated above, please include a written explanation with the product when returned.

Method of return shipment shall be the same or equal to the method by which the item was received by Pelco.

RETURNS

In order to expedite parts returned to the factory for repair or credit, please call the factory at (800) 289-9100 or (559) 292-1981 to obtain an authorization number (CA number if returned for credit, and RA number if returned for repair).

All merchandise returned for credit may be subject to a 20% restocking and refurbishing charge.

Goods returned for repair or credit should be clearly identified with the assigned CA or RA number and freight should be prepaid. Ship to the appropriate address below.

If you are located within the continental U.S., Alaska, Hawaii or Puerto Rico, send goods to:

Service Department
Pelco
3500 Pelco Way
Clovis, CA 93612-5699

If you are located outside the continental U.S., Alaska, Hawaii or Puerto Rico and are instructed to return goods to the USA, you may do one of the following:

If the goods are to be sent by a COURIER SERVICE, send the goods to:

Pelco
3500 Pelco Way
Clovis, CA 93612-5699 USA

If the goods are to be sent by a FREIGHT FORWARDER, send the goods to:

Pelco c/o Expeditors
473 Eccles Avenue
South San Francisco, CA 94080 USA
Phone: 650-737-1700
Fax: 650-737-0933

REVISION HISTORY

Manual #	Date	Comments
C202M	4/91	Original version.
C202M-A	2/98	Improved, stronger versions of the mounts per ECO #97-429 and ECO #97-450. Changed manual to new format and manual pagination.
C202M-B	4/99	Removed Figure 1 and Table A and created separate service manual. Revised to new format.