

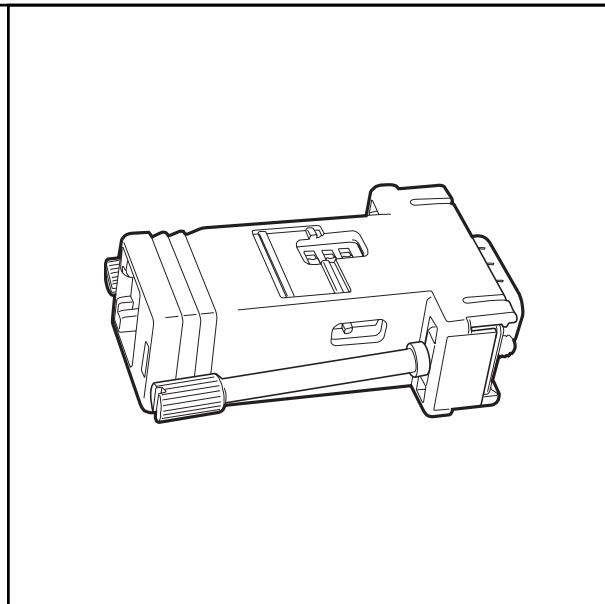

Data Adapters



DX2000DA9, DX2000DA9T, & DX2000DA25T

C697M-A (7/02)

IMPORTANT SAFEGUARDS AND WARNINGS

Observe the following WARNINGS before installing and using this product.

1. Installation and servicing should be done only by qualified service personnel and conform to all local codes.
2. Unless the unit is specifically marked as a NEMA Type 3, 3R, 3S, 4, 4X, 6, or 6P enclosure, it is designed for indoor use only and it must not be installed where exposed to rain and moisture.
3. Only use replacement parts recommended by Pelco.

The product and/or manual may bear the following marks:



This symbol indicates that dangerous voltage constituting a risk of electric shock is present within this unit.



This symbol indicates that there are important operating and maintenance instructions in the literature accompanying this unit.



Please thoroughly familiarize yourself with the information in this manual prior to installation and operation.

UNPACKING INSTRUCTIONS

Unpack and inspect all parts carefully. Save the shipping carton, boxes, and inserts. They are the safest manner in which to make future shipments.

If an item needs to be returned to the factory for repair, consult the WARRANTY AND RETURN section of this manual for instructions.

DESCRIPTION

The DX2000 Data Adapters are used to connect any serial device, such as a cash register, retail point-of-sale (POS) terminal, or bank automated teller machine (ATM), to the DX2000 Digital Video Recorder (DVR) or DX2000 Data Hub.

Each DX2000 DVR can directly control one device per data port (the DX2000 DVR has four ports). In order to control multiple devices through a single data port, you must use a data hub. Up to seven devices can be connected to each data hub and each device requires an adapter. Up to four DX2000 Data Hubs can be daisy-chained together. Refer to Figure 1.

The data adapters convert serial RS-232 data to optical code for use by the DVR or data hub. They also provide electrical isolation for the POS/ATM devices. The data adapters' output is an RJ-45 connector that lets you connect RJ-45 or RJ-11 modular cable to the DVR or data hub.

MODELS

Typically, the DX2000DA9 Data Adapter is used when the serial device has a serial port dedicated to output to the DVR. If all of the serial device's ports are being used by other devices, you can use the DX2000DA9T or DX2000DA25T to tap into a port and allow data to flow to the existing device in addition to the DVR.

- | | |
|-------------|-----------------------------------------------------------------------------------------------------------------------------------------------------------------------------------------|
| DX2000DA9 | DB9 adapter connects directly to POS/ATM device's output data port; includes 25-foot (7.6 m) modular RJ-45 cable and DB9 gender changer |
| DX2000DA9T | DB9 adapter connects to POS/ATM device's output data cable; includes 25-foot (7.6 m) modular RJ-45 cable and a "Y" cable |
| DX2000DA25T | DB25 "T" adapter connects directly to POS/ATM device's output data port or cable; can also connect to an ATM's network router output port; includes 25-foot (7.6 m) modular RJ-45 cable |

OPTIONAL COMPATIBLE PRODUCTS

- | | |
|----------|-------------------------------------------------------------------------------------------------------------------------------------------------------------------------------------------------------------------------------------------------------------------------------------------------------------------------------|
| DX2000DH | Data Hub. The DX2000DH Data Hub provides local connection for up to seven additional ATM or cash register/POS devices. The hub allows transaction data to be delivered to the DX2000 over a single cable. The devices can be up to 4,000 feet (1,219 m) from the DVR, and up to four data hubs can be daisy-chained together. |
|----------|-------------------------------------------------------------------------------------------------------------------------------------------------------------------------------------------------------------------------------------------------------------------------------------------------------------------------------|

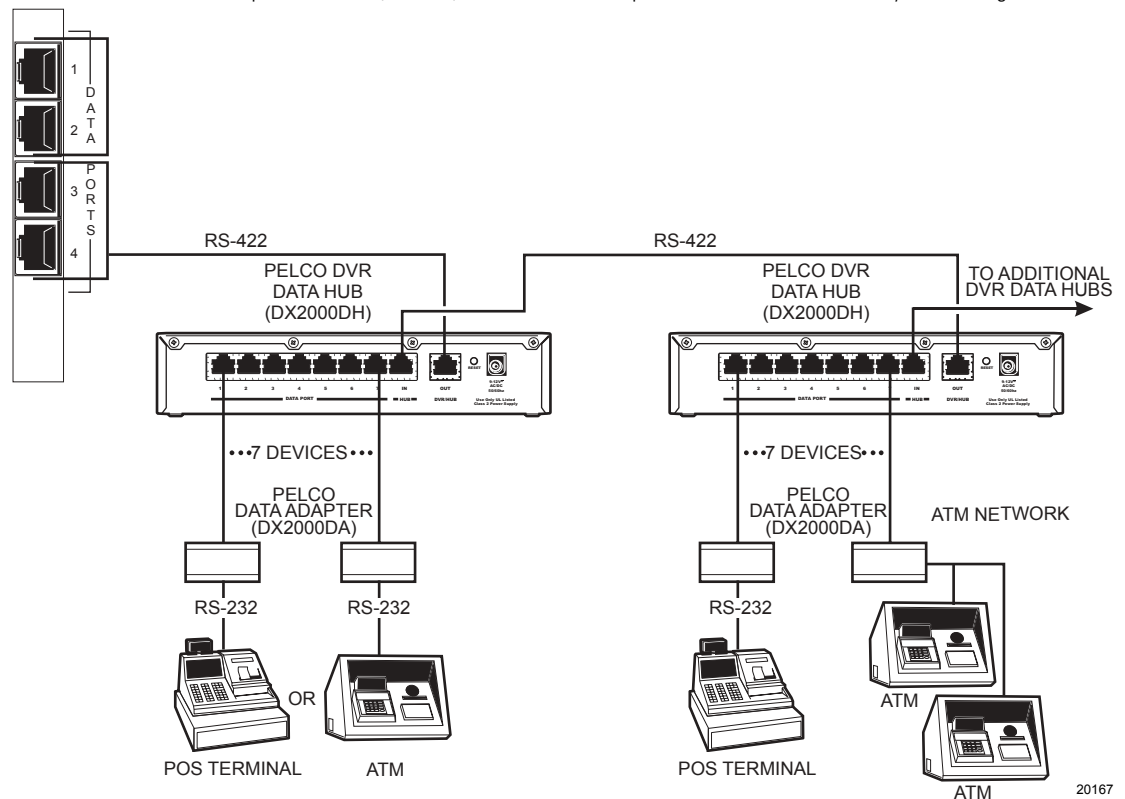

20167

POS CONFIGURATIONS

DX2000DA9 POS CONFIGURATION

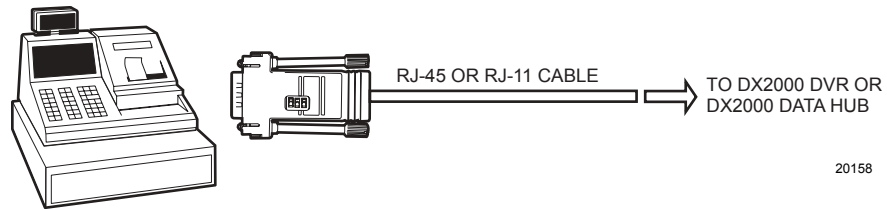

20158

Figure 2. DX2000DA9 POS Configuration

Use the DX2000DA9 Data Adapter to connect a POS device's DB9 serial output port to the DVR or data hub. You can use RJ-45 or RJ-11 cable.

DX2000DA9T POS CONFIGURATION

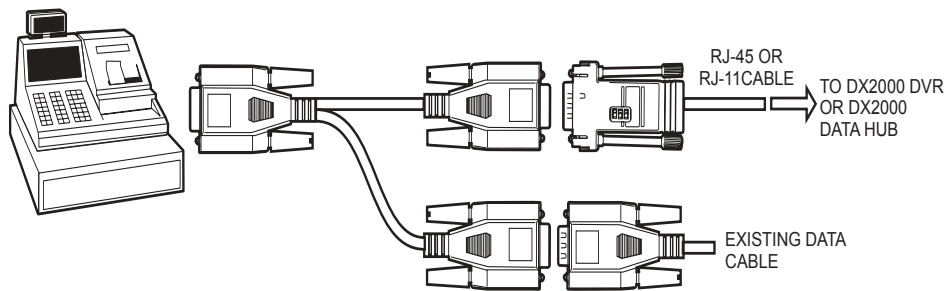
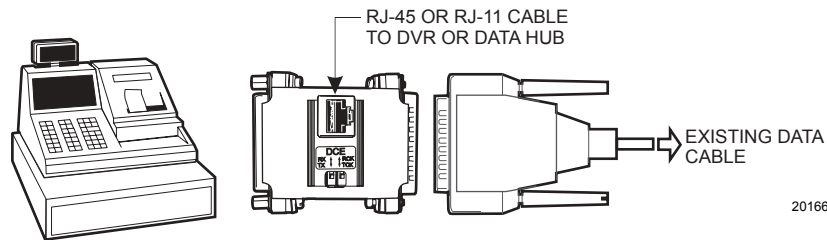

Figure 3. DX2000DA9T POS Configuration

Use the DX2000DA9T Data Adapter and "Y" cable to connect a POS device's DB9 serial output port to an existing output data cable (pole display). Use RJ-45 or RJ-11 cable from the data adapter to the DVR or data hub.

DX2000DA25T POS CONFIGURATION



20166

Figure 4. DX2000DA25T POS Configuration

The DX2000DA25T can be used to connect the DVR or data hub to a POS device's DB25 serial port and to an existing output data cable (pole display). Use RJ-45 or RJ-11 cable from the data adapter to the DVR or data hub.

ATM CONFIGURATIONS

DX2000DA9 ATM CONFIGURATION

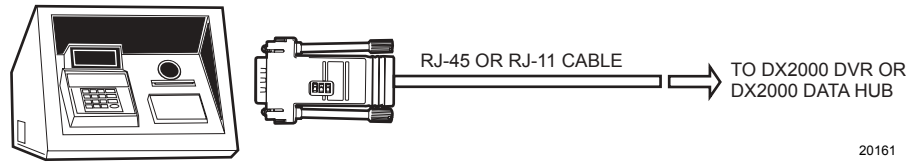

Figure 5. DX2000DA9 ATM Configuration

Use the DX2000DA9 Data Adapter to connect an ATM's DB-9 serial output port to the DVR or data hub. You can use an RJ-45 or RJ-11 cable.

DX2000DA25T ATM CONFIGURATION

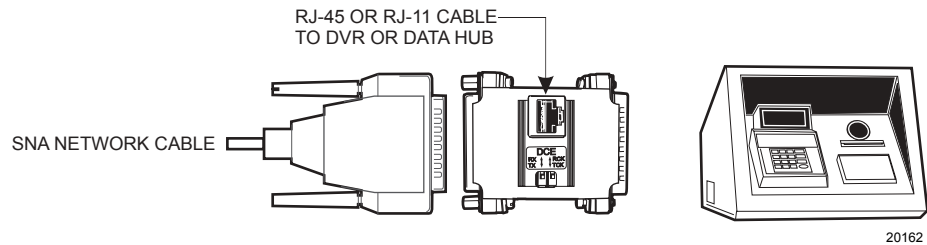

Figure 6. DX2000DA25T ATM Configuration

Use the DX2000DA25T Data Adapter to connect the existing DB25 SNA (Systems Network Architecture) network cable to the ATM. Use RJ-45 or RJ-11 cable from the data adapter to the DVR or data hub.

DX2000DA25T ATM ROUTER OR MODEM CONFIGURATION

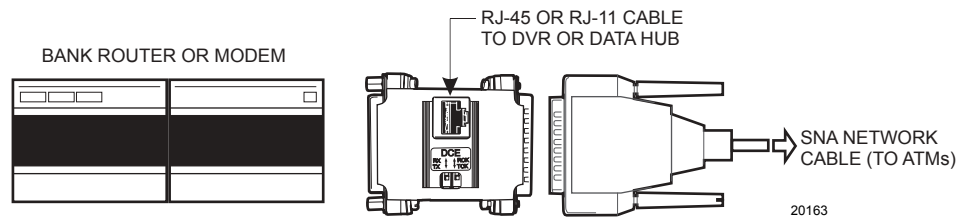

Figure 7. DX2000DA25T Router or Modem Configuration

Use the DX2000DA25T Data Adapter to connect the SNA network router (or modem) to the SNA network cable. Use RJ-45 or RJ-11 cable from the data adapter to the DVR or data hub.

SWITCH SETTINGS

DX2000DA9/DX2000DA9T ADAPTER SWITCH SETTINGS

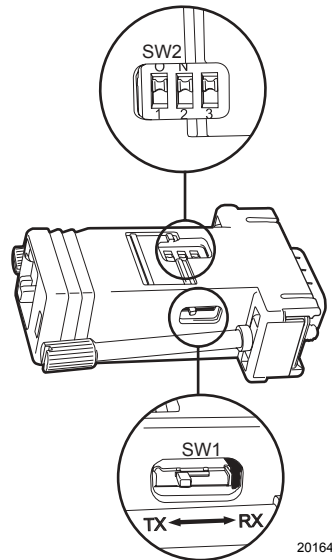

Figure 8. DX2000DA9 Adapter Switch Settings

Switch SW1 lets you choose between data transmission (TX) or reception (RX) for the POS/ATM device's output. Set the switch to the TX position (factory default) when connecting directly to the device's DB9 output port. If connecting to the device's existing output data cable, you may have to change the switch to the RX position if you are not using a straight data cable.

The three SW2 handshake switches let you enable RS-232 hardware handshaking for the device's data port. Set all three to ON (up) to enable and all three down to disable.

DX2000DA25T ADAPTER SWITCH SETTINGS

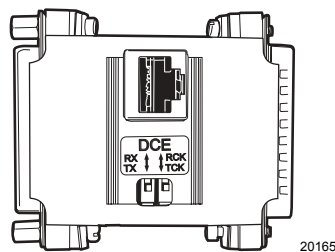

Figure 9. DX2000DA25T Adapter Switch Settings

The data select switch (left switch) lets you choose between data transmission (TX) or reception (RX) for the POS/ATM device's output. Set the switch to the TX position (factory default) when connecting directly to the device's DB25 output port. If connecting to the device's existing output data cable, you may have to change the switch to the RX position if you are not using a straight data cable.

For an ATM network connection, the data clock select switch (right switch) lets you choose between the ATM network's transmit (TCK) and receive (RCK) clock. You may have to change the switch position depending on the type of network connection being used.

The data select and data clock select switches typically should be set to the same position (both transmit or receive).

WARRANTY AND RETURN INFORMATION

WARRANTY

Pelco will repair or replace, without charge, any merchandise proved defective in material or workmanship for a period of one year after the date of shipment. Exceptions to this warranty are as noted below:

- Five years on Pelco manufactured cameras (CC3500/CC3600/CC3700 and MC3500/MC3600 Series); two years on all other cameras.
- Three years on Genex® Series (multiplexers, server, and keyboard).
- Two years on all standard motorized or fixed focal length lenses.
- Two years on Legacy®, Camclosure™ Camera Systems, CM6700/CM6800/CM8500/CM9500/CM9740/CM9760 Matrix, DF5 and DF8 Series Fixed Dome products.
- Two years on Spectra®, Esprit™, and PS20 Scanners, including when used in continuous motion applications.
- Two years on Esprit™ and WW5700 series window wiper (excluding wiper blades).
- Eighteen months on DX Series digital video recorders.
- One year (except video heads) on video cassette recorders (VCRs). Video heads will be covered for a period of six months.
- Six months on all pan and tilts, scanners or preset lenses used in continuous motion applications (that is, preset scan, tour and auto scan modes).

Pelco will warrant all replacement parts and repairs for 90 days from the date of Pelco shipment. All goods requiring warranty repair shall be sent freight prepaid to Pelco, Clovis, California. Repairs made necessary by reason of misuse, alteration, normal wear, or accident are not covered under this warranty.

Pelco assumes no risk and shall be subject to no liability for damages or loss resulting from the specific use or application made of the Products. Pelco's liability for any claim, whether based on breach of contract, negligence, infringement of any rights of any party or product liability, relating to the Products shall not exceed the price paid by the Dealer to Pelco for such Products. In no event will Pelco be liable for any special, incidental or consequential damages (including loss of use, loss of profit and claims of third parties) however caused, whether by the negligence of Pelco or otherwise.

The above warranty provides the Dealer with specific legal rights. The Dealer may also have additional rights, which are subject to variation from state to state.

If a warranty repair is required, the Dealer must contact Pelco at (800) 289-9100 or (559) 292-1981 to obtain a Repair Authorization number (RA), and provide the following information:

1. Model and serial number
2. Date of shipment, P.O. number, Sales Order number, or Pelco invoice number
3. Details of the defect or problem

If there is a dispute regarding the warranty of a product which does not fall under the warranty conditions stated above, please include a written explanation with the product when returned.

Method of return shipment shall be the same or equal to the method by which the item was received by Pelco.

RETURNS

In order to expedite parts returned to the factory for repair or credit, please call the factory at (800) 289-9100 or (559) 292-1981 to obtain an authorization number (CA number if returned for credit, and RA number if returned for repair).

All merchandise returned for credit may be subject to a 20% restocking and refurbishing charge.

Goods returned for repair or credit should be clearly identified with the assigned CA or RA number and freight should be prepaid. Ship to the appropriate address below.

If you are located within the continental U.S., Alaska, Hawaii or Puerto Rico:

Service Department
Pelco
3500 Pelco Way
Clovis, CA 93612-5699

If you are located outside the continental U.S., Alaska, Hawaii or Puerto Rico:

Intermediate Consignee
American Overseas Air Freight
320 Beach Road
Burlingame, CA 94010
USA

Ultimate Consignee
Pelco
3500 Pelco Way
Clovis, CA 93612-5699
USA

REVISION HISTORY

Manual #	Date	Comments
C697M	4/02	Original version.
C697M-A	7/02	Manual revised because of a change to the DX2000DA9T adapter and inclusion of a "Y" cable.



World Headquarters
3500 Pelco Way
Clovis, California 93612 USA

USA & Canada
Tel: 800/289-9100
Fax: 800/289-9150

International
Tel: 1-559/292-1981
Fax: 1-559/348-1120

www.pelco.com

ISO9001

Orangeburg, New York | Las Vegas, Nevada | Eindhoven, The Netherlands | Wokingham, United Kingdom | Montreal, Canada