



3500 Pelco Way
Clovis, CA 93612-5699
USA

In North America & Canada:
Tel (800) 289-9100
FAX (800) 289-9150

International Customers:
Tel (1-559) 292-1981
FAX (1-559) 348-1120

www.pelco.com

C605M-C (10/04) **DA104DT** **Distribution Amplifier**

IMPORTANT SAFEGUARDS AND WARNINGS

Prior to installation and use of this product, the following WARNINGS should be observed.

1. Installation and servicing should only be done by qualified service personnel and conform to all local codes.
2. Unless the unit is specifically marked as a NEMA Type 3, 3R, 3S, 4, 4X, 6 or 6P enclosure, it is designed for indoor use only and it must not be installed where exposed to rain and moisture.
3. Only use replacement parts recommended by Pelco.
4. After replacement/repair of this unit's electrical components, conduct a resistance measurement between line and exposed parts to verify the exposed parts have not been connected to line circuitry.

The product and/or manual may bear the following marks:



This symbol indicates that dangerous voltage constituting a risk of electric shock is present within this unit.



This symbol indicates that there are important operating and maintenance instructions in the literature accompanying this unit.



Please thoroughly familiarize yourself with the information in this manual prior to installation and operation.

DESCRIPTION

The DA104DT Distribution Amplifier provides four independent video outputs from a single video input. Solid-state circuitry consisting of four identical video amplifiers in parallel provide four equal 75 ohm loads, which allow the video outputs to be viewed without distortion or loss of clarity.

The DA104DT is available as a desk top unit; up to three units can be rack mounted using the R300 Rack Mount Kit. (Blank filler panels are provided for fewer than three modules.) Two units can also be mounted side-by-side in a single desktop chassis using the DT200.

MODELS

DA104DT	Distribution amplifier (1 input, 4 outputs), 120 VAC input.
DA104DT/220	Same as DA104DT except 230 VAC input.

INSTALLATION

Plug power cord into a 120 VAC, 60 Hz or 230 VAC, 50 Hz source depending on model ordered. Connect the input to a video camera with 75 ohm coax cable. Each output is capable of supplying video to more than one monitor. If more than one monitor is used, only the last monitor in line must be terminated. The other monitors must be set for high impedance input. An output used with a single monitor will require that monitor to be terminated in 75 ohm impedance.

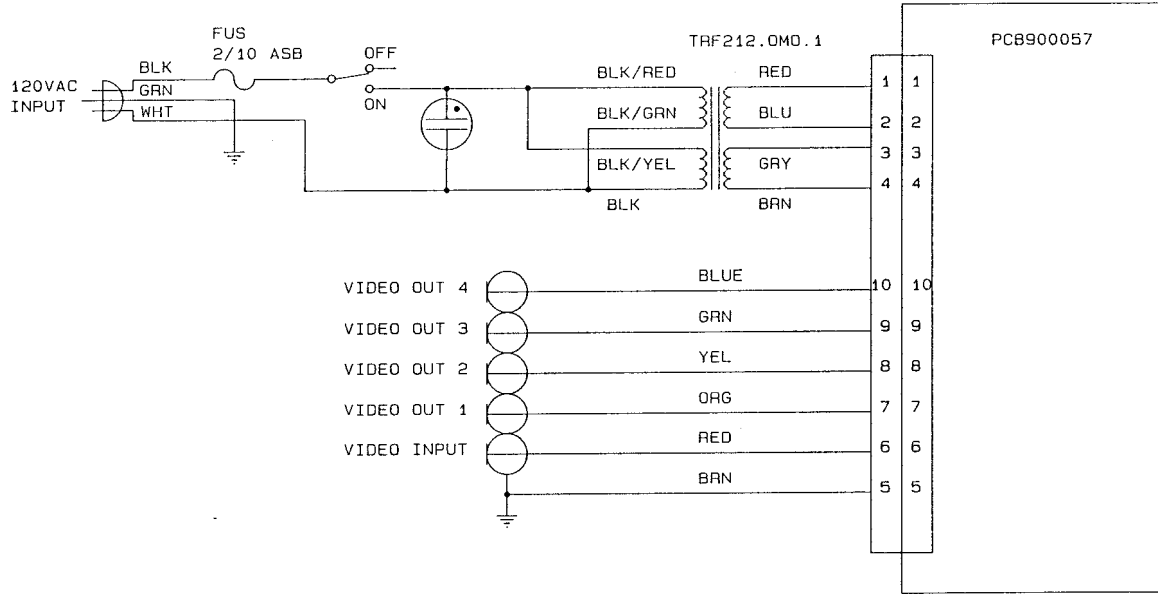

Figure 1. DA104DT 120 VAC Input Diagram

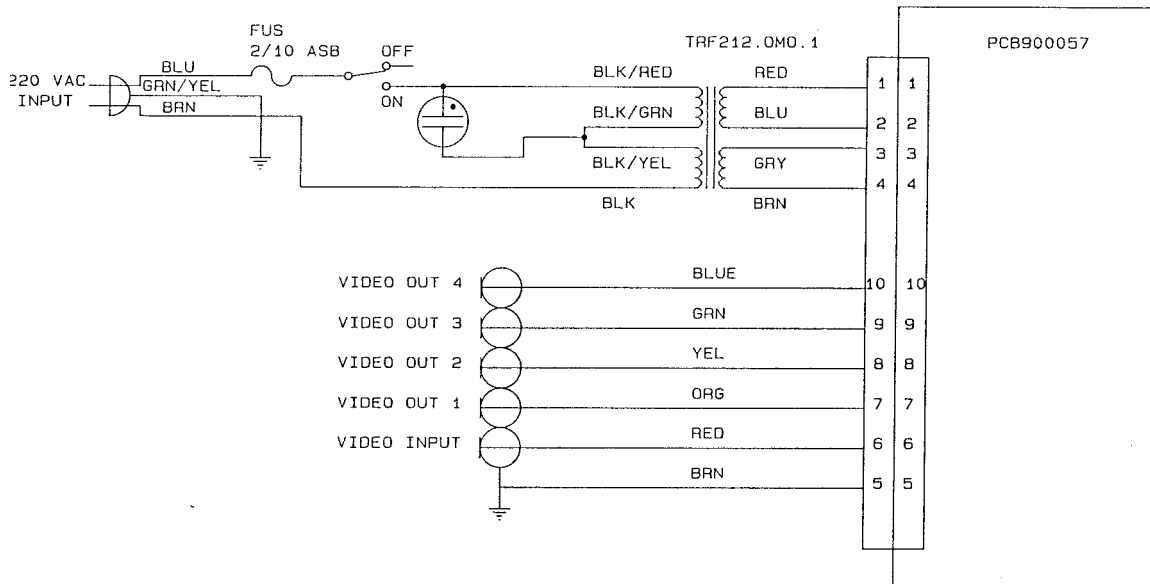

Figure 2. DA104DT 230 VAC Input Diagram

OPERATION

Turn the power switch on; a panel lamp will indicate that the unit is on.

There are no adjustments necessary for proper operation of this unit.

MAINTENANCE

The DA104DT requires no periodic maintenance. In the event of any apparent amplifier failure, check all cables and connectors first.

Before any attempt is made to troubleshoot the circuitry, check for a proper video signal at the input.

Refer to the Service/Maintenance manual for schematic.

- Go to Pelco's web site at www.pelco.com and find service manual C605SM.
- Contact Pelco's Literature Department and request service manual C605SM.

SPECIFICATIONS

ELECTRICAL

Input Voltage: 120 VAC, 50/60 Hz, or 230 VAC

Power ON/OFF: Rocker switch

Power Requirements: 2.5 vA

Power Cord: 3-wire grounded #18 AWG

Input Impedance: 75 ohms

Output Impedance: 75 ohms

Gain: Unity

Frequency Response: Flat within ± 1 dB to 10 MHz

Max. Signal Level: 2 volts p-p

Connectors: BNC

Fuse Protection: 3 AG, .2 ASB

GENERAL

Construction:
Cover Steel, black polyester powder coat
Chassis Steel, zinc plated
Panel Aluminum, black polyester powder coat with white silkscreen

Dimensions: 1.75 in. H x 5.50 in. W x 8.80 in. D (4.45 x 13.97 x 22.35 cm)

Environment: 32°F to 120°F (0°C to +48.89°C)

Humidity Tolerance: 85% (non-condensing)

Weight
Unit: 3 lb (1.35 kg)
Shipping: 4 lb (1.81 kg)

Ratings: Meets NEMA Type 1, IP 20 standards

(Design and product specifications subject to change without notice.)

REGULATORY NOTICES

This equipment has been tested and found to comply with the limits of a Class B digital device, pursuant to part 15 of the FCC rules. These limits are designed to provide reasonable protection against harmful interference in a residential installation. This equipment generates, uses, and can radiate radio frequency energy and, if not installed and used in accordance with the instructions, may cause harmful interference to radio communications. However there is no guarantee that the interference will not occur in a particular installation. If this equipment does cause harmful interference to radio or television reception, which can be determined by turning the equipment off and on, the user is encouraged to try to correct the interference by one or more of the following measures:

- Reorient or relocate the receiving antenna.
- Increase the separation between the equipment and the receiver.
- Connect the equipment into an outlet on a circuit different from that to which the receiver is connected.
- Consult the dealer or an experienced radio/TV technician for help.

WARRANTY AND RETURN INFORMATION

WARRANTY

Pelco will repair or replace, without charge, any merchandise proved defective in material or workmanship **for a period of one year** after the date of shipment.

Exceptions to this warranty are as noted below:

- Five years on FT/FR8000 Series fiber optic products and the following fixed camera models: CC3701H-2, CC3701H-2X, CC3751H-2, CC3651H-2X, MC3651H-2, and CC3651H-2X.
- Three years on all other fixed camera models (including Camclosure® Integrated Camera Systems) and Genex® Series (multiplexers, server, and keyboard).
- Two years on all standard motorized or fixed focal length lenses.
- Two years on Legacy®, CM6700/CM6800/CM8500/CM9500/CM9700 Series Matrix, DF5 and DF8 Series Fixed Dome products.
- Two years on Spectra®, Esprit®, and PS20 Scanners, including when used in continuous motion applications.
- Two years on Esprit® and WW5700 Series window wiper (excluding wiper blades).
- Eighteen months on DX Series digital video recorders and NVR300 Series network video recorders.
- One year (except video heads) on video cassette recorders (VCRs). Video heads will be covered for a period of six months.
- Six months on all pan and tilts, scanners or preset lenses used in continuous motion applications (that is, preset scan, tour and auto scan modes).

Pelco will warrant all replacement parts and repairs for 90 days from the date of Pelco shipment. All goods requiring warranty repair shall be sent freight prepaid to Pelco, Clovis, California. Repairs made necessary by reason of misuse, alteration, normal wear, or accident are not covered under this warranty.

Pelco assumes no risk and shall be subject to no liability for damages or loss resulting from the specific use or application made of the Products. Pelco's liability for any claim, whether based on breach of contract, negligence, infringement of any rights of any party or product liability, relating to the Products shall not exceed the price paid by the Dealer to Pelco for such Products. In no event will Pelco be liable for any special, incidental or consequential damages (including loss of use, loss of profit and claims of third parties) however caused, whether by the negligence of Pelco or otherwise.

The above warranty provides the Dealer with specific legal rights. The Dealer may also have additional rights, which are subject to variation from state to state.

If a warranty repair is required, the Dealer must contact Pelco at (800) 289-9100 or (559) 292-1981 to obtain a Repair Authorization number (RA), and provide the following information:

1. Model and serial number
2. Date of shipment, P.O. number, Sales Order number, or Pelco invoice number
3. Details of the defect or problem

If there is a dispute regarding the warranty of a product which does not fall under the warranty conditions stated above, please include a written explanation with the product when returned.

Method of return shipment shall be the same or equal to the method by which the item was received by Pelco.

RETURNS

In order to expedite parts returned to the factory for repair or credit, please call the factory at (800) 289-9100 or (559) 292-1981 to obtain an authorization number (CA number if returned for credit, and RA number if returned for repair).

All merchandise returned for credit may be subject to a 20% restocking and refurbishing charge.

Goods returned for repair or credit should be clearly identified with the assigned CA or RA number and freight should be prepaid. Ship to the appropriate address below.

If you are located within the continental U.S., Alaska, Hawaii or Puerto Rico, send goods to:

Service Department
Pelco
3500 Pelco Way
Clovis, CA 93612-5699

If you are located outside the continental U.S., Alaska, Hawaii or Puerto Rico and are instructed to return goods to the USA, you may do one of the following:

If the goods are to be sent by a COURIER SERVICE, send the goods to:

Pelco
3500 Pelco Way
Clovis, CA 93612-5699 USA

If the goods are to be sent by a FREIGHT FORWARDER, send the goods to:

Pelco c/o Expeditors
473 Eccles Avenue
South San Francisco, CA 94080 USA
Phone: 650-737-1700
Fax: 650-737-0933

REVISION HISTORY

Manual #	Date	Comments
C605M-C	6/99	Original version.
	10/04	Removed agency logos; updated warranty and return information.