

m Bev 10-76

OPERATING INSTRUCTIONS

Adjustment and Repair
Instructions • Parts List

SAMPLE



Do not remove

MODELS "6-S"—"6-SFB"—"6-SR6"

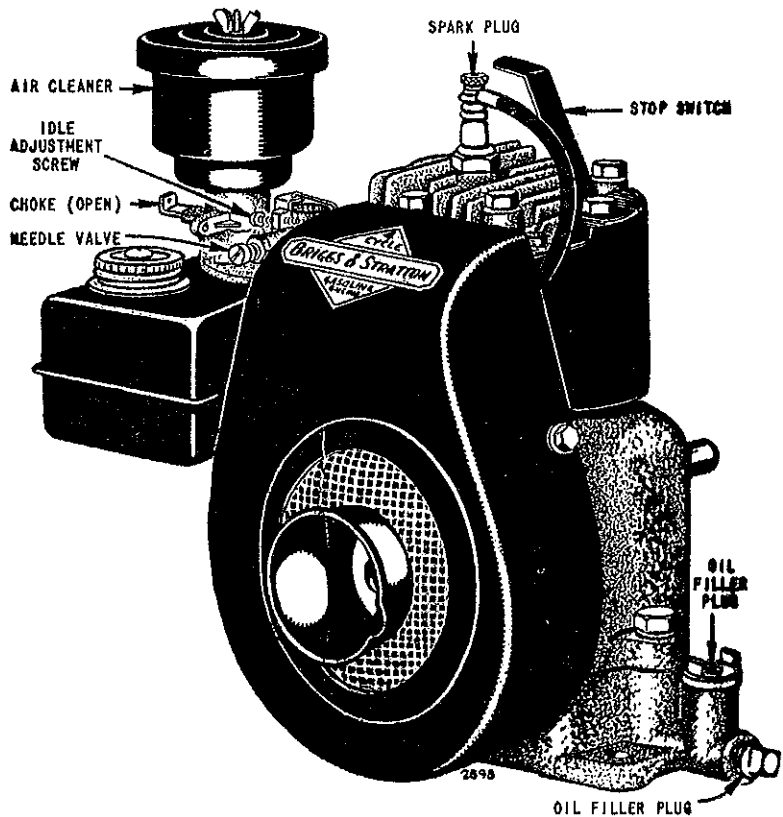

BRIGGS & STRATTON CORP., Milwaukee 1, Wis., U. S. A.

IMPORTANT SAFETY INFORMATION AND INSTRUCTIONS FOR ENGINE SELECTION ENGINE INSTALLATION ENGINE OPERATION

In the USA and Canada,
our 24 hour hotline is:

18002333723

Briggs & Stratton Corporation
Milwaukee, Wisconsin 53201

www.briggsandstratton.com

Keep these instructions for future reference.



Before installing and operating this engine read and observe all warnings, cautions and instructions on both sides of this sheet, on the engine, and in the operating & maintenance instructions.

NOTE: This sheet of instructions and safety information is not meant to cover all possible conditions and situations that may occur. Read entire Operating & Maintenance Instructions for this engine AND the instructions for the equipment this engine powers. Failure to follow instructions and safety information could result in serious injury or death.

The safety alert symbol () is used to identify safety information about hazards that can result in personal injury.

A signal word (DANGER, WARNING, or CAUTION) is used with the alert symbol to indicate the likelihood and the potential severity of injury. In addition, a hazard symbol may be used to represent the type of hazard.

 **DANGER** indicates a hazard which, if not avoided, will result in death or serious injury.

 **WARNING** indicates a hazard which, if not avoided, could result in death or serious injury.

 **CAUTION** indicates a hazard which, if not avoided, might result in minor or moderate injury.

CAUTION, when used **without** the alert symbol, indicates a situation that **could result in damage to the engine.**

HAZARD SYMBOLS AND MEANINGS



Fire



Explosion



Moving Parts



Toxic Fumes



Hot Surface



Shock



Kickback

(OVER)

FORM MS-6445-01/03

ENGINE SELECTION

 WARNING

Failure to select the correct engine could result in fire or explosion.

- Some engines are unique and designed for specific applications or types of equipment. If this engine will be used to build new equipment, contact Briggs & Stratton to ensure that the engine is appropriate for the intended use.
Note: For all Go-karts use only a model 136200 series engine, which offers improved safety and performance.
- Replacement engines should be the same model as the original engine, or be the Briggs & Stratton designated replacement engine. Refer to the Operation & Maintenance Instructions for engine identification information.
Note: For all Go-karts use only a model 136200 series engine, which offers improved safety and performance.
- Do not use Briggs & Stratton engines on 3-wheel All-Terrain Vehicles (ATVs), motor bikes, air craft products, or vehicles intended for use in competitive events. Briggs & Stratton does not approve of or authorize such uses.

ENGINE INSTALLATION



- [1] Do not attempt to install this engine if you do not have the appropriate tools and knowledge of small engine installation procedures. Use only Briggs & Stratton parts. Contact your Authorized Service Dealer for assistance.
- [2] Do not modify the engine in any way without Briggs & Stratton factory approval. Any such modification is at the owner's sole risk.
- [3] If the exhaust system on the old engine was supplied by the equipment manufacturer, you must transfer the exhaust system and related components (original muffler and related pipes, brackets, clamps, and shields) to the new engine. All components must be in good condition.
- [4]



 WARNING	Install muffler (and muffler deflector if used) so outlet points away from operator, fuel tank, and equipment, and so muffler heat will not damage or deform engine and components.
	
- [5]



 WARNING	Ensure all fuel lines and fittings are properly assembled and do not leak. Replacement parts must be the same model as the original.
	
- [6]



 WARNING	Ensure all wiring, including safety switches and engine shut-off components are completely installed and functioning properly.
	
- [7] Set engine speed to equipment manufacturer's specification. Refer to equipment manufacturer's manual. Do not tamper with governor springs, or other parts that will increase engine speed above specification.

- [8]







 WARNING	All engine parts, including fuel cap, spark plug, muffler, air cleaner, and covers and guards for drive components (gears, belts, shafts, couplings, etc.) must be in place before attempting to start engine.
	
- [9]

 WARNING	If engine is installed on walk behind lawn mower, all mower components, including cutting blade, must be correctly installed before attempting to start engine.
	
- [10]

 WARNING	When working on the engine or equipment, remove spark plug wire from spark plug. For electric start, remove negative wire from battery.
	
- [11]

 WARNING	Do not check for spark with spark plug removed. Use Briggs & Stratton spark tester #19368.
	

ENGINE OPERATION

	 WARNING
	When adding fuel:
<p>Turn engine off and let engine cool at least 2 minutes before removing gas cap.</p> <p>Fill fuel tank outdoors or in well-ventilated area. Fill tank to about 1 inch below lowest portion of neck to allow for fuel expansion.</p> <p>Keep gasoline away from sparks, open flames, pilot lights, heat, and other ignition sources.</p>	
	 WARNING
	When starting engine:
<p>Remove all external equipment/engine loads.</p> <p>Wait until spilled fuel is evaporated. Start engine outdoors.</p> <p>Pull cord slowly until resistance is felt, then pull rapidly.</p> <p>If engine floods, set choke to OPEN/RUN, place throttle in FAST and crank until engine starts.</p>	
	 WARNING
	When operating equipment:
<p>Do not tip engine or equipment at angle which causes gasoline to spill.</p> <p>Run engine outdoors. Do not run in enclosed area, even if doors or windows are open.</p> <p>Do not choke carburetor to stop engine.</p>	

IMPORTANT!

Read these instructions carefully before operating this Engine for the first time.

Guessing how to run it may cause you unnecessary inconvenience, aggravation, or failure to receive the fine service that is built into it.

There is a right way to operate this Engine. This book tells you how.

Each Engine is carefully tested and adjusted at the factory before packing for shipment, and if correctly operated will perform beyond your expectations.

DO NOT START THIS ENGINE UNTIL YOU HAVE READ CAREFULLY THE INSTRUCTIONS ON PREPARING AND USING THE ENGINE, PAGES 3 TO 5.

For Maintenance Adjustments, see pages 6 and 7.

If you have difficulty in operating your engine and you need outside help, contact your dealer or the nearest member of our Authorized Service Organization. See back cover.

Briggs & Stratton manufactured only the engine on your powered equipment. For other service or parts, write to the manufacturer of the complete equipment or see the dealer from whom purchased.

CAUTION !

1. **PROVIDE EFFICIENT VENTILATION.** Exhaust gases contain carbon monoxide which is odorless and a deadly poison. Proper care must be taken to provide efficient ventilation.
2. **DO NOT FILL GASOLINE TANK WHILE ENGINE IS RUNNING.** Avoid spilling gasoline on a hot engine — this may cause an explosion and serious injury.
3. **KEEP ENGINE CLEAN.** This engine is air-cooled. If cooling system becomes clogged, serious damage may result. Therefore, keep the blower screen, fins on flywheel, cylinder head and block free from grass or dirt.

GENERAL INFORMATION

This engine is a single cylinder, L-Head air-cooled type; bore 2" and stroke 2". It rated at:

1.20 h.p. at 2200 r.p.m. 1.48 h.p. at 2700 r.p.m. 1.60 h.p. at 3200 r.p.m.

The horsepower ratings listed above are established by standard I.C.E.I. procedures. For practical operation, the horsepower loading should not exceed 85 per cent of these ratings. Engine power will decrease 3½ per cent for each 1,000 feet above sea level, and 1 per cent for each 10 degrees above 60 degrees F.

PREPARATION OF ENGINE BEFORE STARTING

Fill Crankcase With Oil

Remove the oil filler plug. Use a screwdriver or bar. Place the engine level. Fill the crankcase to the top of the filler pipe. Replace the plug. Screw it down tight.

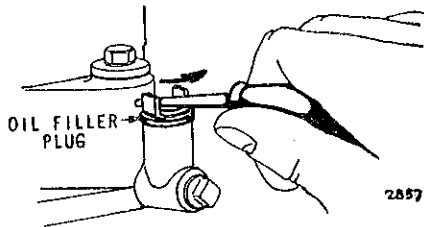

For temperatures 32° and above use Mobiloil Arctic S. A. E. No. 20 oil.

For temperatures below 32° use Mobiloil No. 10W (S. A. E. No. 10W) oil.

For temperatures below 0° add 1% of kerosene to the S. A. E. No. 10W oil for each degree below 0° but do not add more than 30%.

Put Oil In Air Cleaner

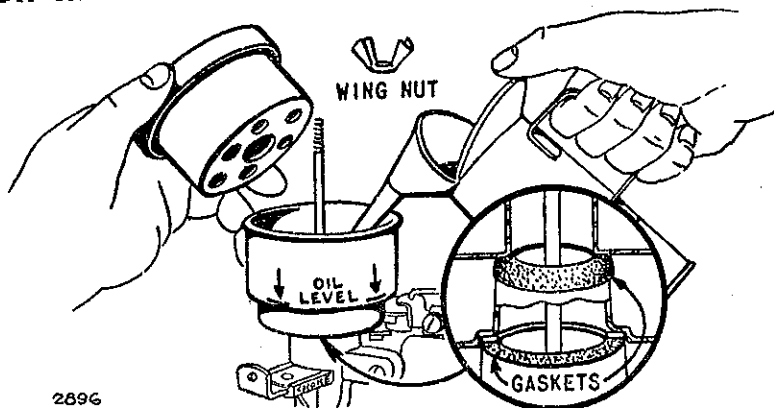

Air cleaner protects engine from grit and dirt. Use the same oil as in the crankcase. Remove wing nut. Lift out filter element. Pour in oil to "oil level" mark at end of arrows. Replace element and wing nut. Be sure gaskets are in place. See inset.

Fill Fuel Tank

Use a good grade of regular, clean, fresh gasoline such as Mobilgas. *Never use gasoline that has been standing in a can for several months as gum may form under such conditions and may clog the carburetor, fuel tank, etc.* See that vent hole in cap is open. **DO NOT MIX OIL WITH GASOLINE.**

USING THE ENGINE

To Start Engine

1. Close the Choke

Completely close the carburetor choke by pushing the choke lever in.

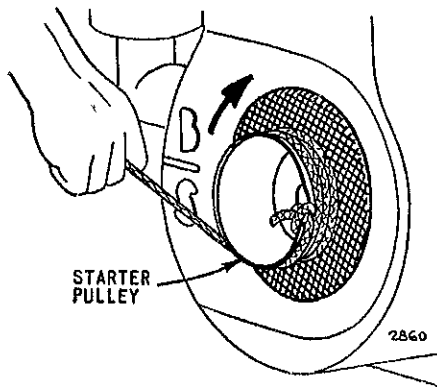
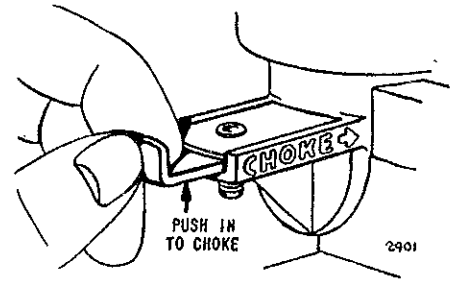

2. Place the Knot In Slot

Wind the starter rope around the pulley in direction shown by arrow. Then turn the pulley in the opposite direction (counterclockwise) until compression is felt. Pull the rope with a quick full arm stroke. Repeat if necessary with choke opened slightly. When engine starts open choke gradually.

RECOIL STARTER. Pull rope out slowly until starter engages. Then pull fast. Keep firm hold on starter grip and return rope slowly.

To Stop Engine

Press the stop switch against the end of spark plug until engine stops.

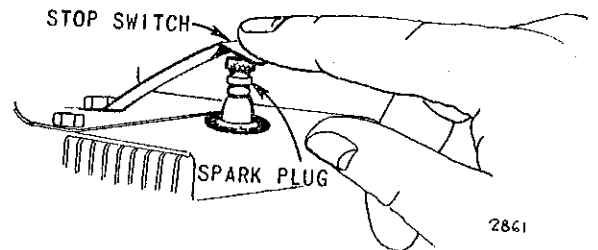

Change Oil (Crankcase)

Change oil after 5 hours of operation. Remove the oil drain plug. Drain oil. Replace drain plug. Remove oil filler cap. Refill with new oil. Replace oil filler cap. Add oil regularly after each 5 hours of operation. Thereafter change oil every 25 hours of operation.

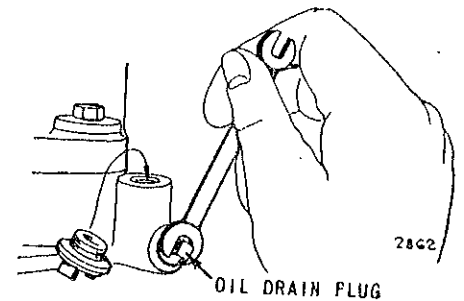

USING THE ENGINE

Change Oil (Air Cleaner)

Check the air cleaner frequently (every hour under extremely dusty conditions). Clean and refill at least every 25 hours.

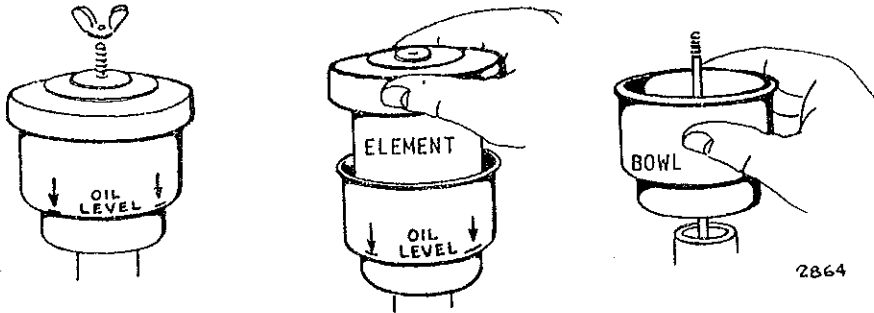

1. Remove Wing Nut
2. Lift Out Element
3. Lift Off Bowl
4. Pour out old oil. Wash the filter element in gasoline. Clean bowl, wipe dry. Replace bowl. Pour in oil to "oil level" mark shown. Replace filter element and wing nut. Be sure gaskets are in place.

STORAGE INSTRUCTIONS

Engines stored any length of time should be completely drained of fuel to prevent gum deposits forming on essential parts such as the carburetor, fuel filter, fuel lines, and tank.

Such deposits may affect the operation of the engine when again used. Therefore, it is important to follow these instructions before storing the engine:

- a. Remove tank and carburetor from unit and drain completely.
- b. Replace tank and carburetor.
- c. While the engine is still warm, drain and clean the crankcase. Refill with fresh oil.
- d. Remove spark plug, pour one ounce of S. A. E. No. 20 oil into cylinder and crank slowly to spread oil. Replace spark plug.
- e. Clean dirt and chaff from cylinder and cylinder head fins, blower housing, etc.

IMPORTANT NOTICE

This book includes only necessary information for running your engine. Unless you have a thorough knowledge of internal combustion engines and proper tools, we do not recommend that you attempt to make major engine repairs. This does not mean that you shouldn't make necessary adjustments and simple repairs, but in case of emergency we advise you to get in touch with the nearest member of our Nation-wide Service Organization described on page 19.

If detailed repair information is desired, a Repairman's Handbook may be obtained from the factory at \$1.00 per copy. Be sure to specify Model, Type, and Serial Number of your engine when ordering.

MAINTENANCE ADJUSTMENTS

Carburetor Adjustments

a. Adjust carburetor with the fuel tank half full of summer grade "regular" gasoline.

With engine running at normal operating speed (approximately 2700 R.P.M., no load) turn the needle valve in until engine starts to lose speed, indicating a lean mixture. Then open needle valve (turn counterclockwise) very slowly, past the point of smooth operation, until engine just begins to run unevenly. This mixture should be rich enough for good performance under full load.

b. Place throttle in idling position. Engine should idle no slower than 1750 R.P.M. Turn idle speed adjusting screw until this speed is reached.

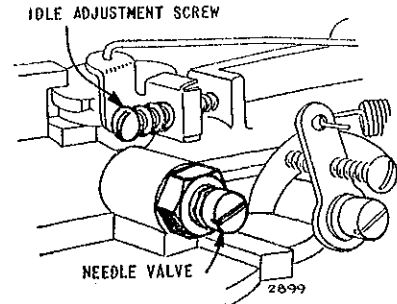

c. Then test the engine under full load. If it does not carry the load satisfactorily, it usually indicates that the mixture is still too lean and it may be necessary to open the needle valve more in order to further richen the mixture. This richer mixture will cause a slight unevenness in idling.

If carburetor throttle acts sluggish or engine does not govern smoothly, it is usually caused by a dirty or gummy throttle.

Governor Adjustments

The correct operating speed range is 2200 to 3200 R.P.M. The standard speed-setting (no load) is 2700 R.P.M. Idle speed is 1750 R.P.M.

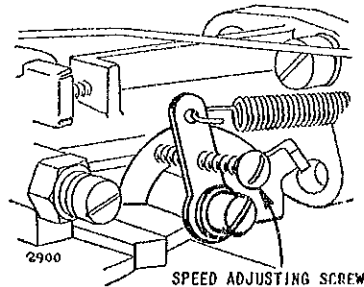

STANDARD GOVERNOR CONTROL. To increase engine speed, turn speed adjusting screw clockwise.

To decrease engine speed, turn speed adjusting screw counterclockwise.

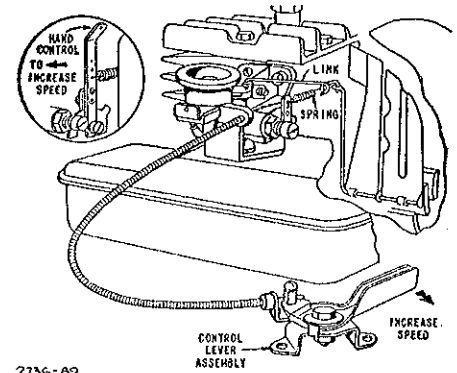

HAND LEVER CONTROL. (See inset above.) Move lever forward to increase speed.

REMOTE GOVERNOR CONTROL. To increase speed move lever on control lever assembly as shown above.

MAINTENANCE ADJUSTMENTS

To Check Spark Plug Gap

Spark plug is 14mm (USE CHAMPION J-8 OR EQUIVALENT). Keep a fresh plug on hand. Clean and reset the gap at .025" every 100 hours of operation. Use some graphite grease on threads when replacing spark plug.

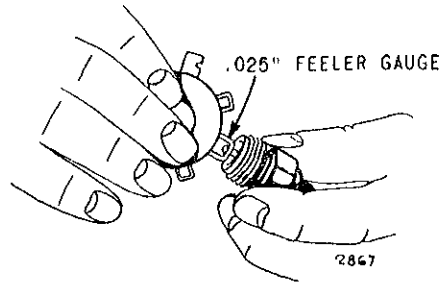

To Adjust and Clean Contact Points

Blower housing, flywheel, and magneto point dust cover must be removed. (See

below.) Points must be clean and line up squarely to make good contact. Do not file points—use fine sandpaper or hone to dress the points. Turn the crankshaft until points open to widest gap. Adjust gap to .020" by loosening the adjusting lock screw and moving contact point bracket up or down. When proper gap is obtained tighten lock screw securely. If either or both points become badly pitted or burned, replace with complete new Contact Point Assembly.

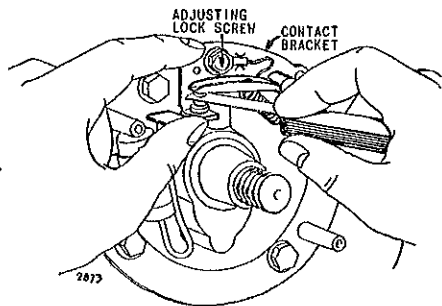

To Remove Flywheel

Rope Starter

Remove blower housing. Place a block of wood under flywheel fin close to flywheel to hold it solid. Use a large wrench 10" or longer. Turn to RIGHT to loosen. After removing nut, washer and pulley, loosen flywheel by holding a wood block against the end of crankshaft and striking it with a hammer. Pull off flywheel. Save the key.

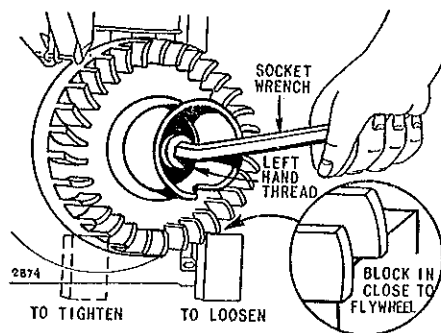

Recoil Starter

Same as above, except turn clutch housing to left (right hand thread).

To Reassemble Flywheel

Clean flywheel hole and tapered end of crankshaft thoroughly. Place keyway of crankshaft up. Put flywheel on shaft and align keyways. Insert the key into keyways and push it securely into place. (If key is partially sheared or damaged, replace with a new Briggs & Stratton Key No. 61760. This is a soft metal key. DO NOT USE A STEEL KEY. Assemble the pulley and spring washer (concave side should be next to flywheel). Place a block of wood under left side of flywheel and draw nut up tight with wrench. Replace blower housing.

**PARTS SECTION
INDEX**

How to Find the Correct Number of Part You Need.....(See below)

Numerical Parts List.....12-17

Illustrations of Parts Groups:

- Cylinder, Piston, Connecting Rod, Crankshaft, and Flywheel Parts.. 9
- Fuel System, Blower Case, and Magneto Parts..... 10
- Starter and Gear Reduction Parts..... 11



**HOW TO FIND THE CORRECT NUMBER
OF THE PART YOU NEED**

- a. Make a note of your engine MODEL NUMBER (not the Serial Number) that appears on the metal nameplate attached to cylinder shield.
- b. Refer to pages illustrating parts and locate the Master Part Number by comparing your old part with illustrations. Assemblies include all part numbers shown in frames in illustration. All parts shown in assembly frames on which part numbers are given can be purchased separately.
- c. After the Master Part Number has been identified, refer to the following Parts List where these Master Part Numbers are listed in numerical order.

THE MASTER PART IS USED ON ALL TYPES OF ENGINES EXCEPT THOSE TYPES LISTED UNDER "NOTE."

- d. If a "Note" appears below the Master Part Number, this means that this part is made differently from the Master Part for certain types, and if your type is listed under "Note" order the part referred to.
- e. If your Engine Type Number does not appear after any part number listed under "Note," order the Master Part Number.
- f. When ordering parts — or writing for service information — always specify the MODEL NUMBER — TYPE NUMBER — and SERIAL NUMBER of your engine.
- g. All parts should be ordered from the nearest member of our Nation-wide Service Organization. (See back cover.) In ordering parts by mail, selling prices will be furnished on request or parts will be shipped at prevailing prices.

PARTS SECTION

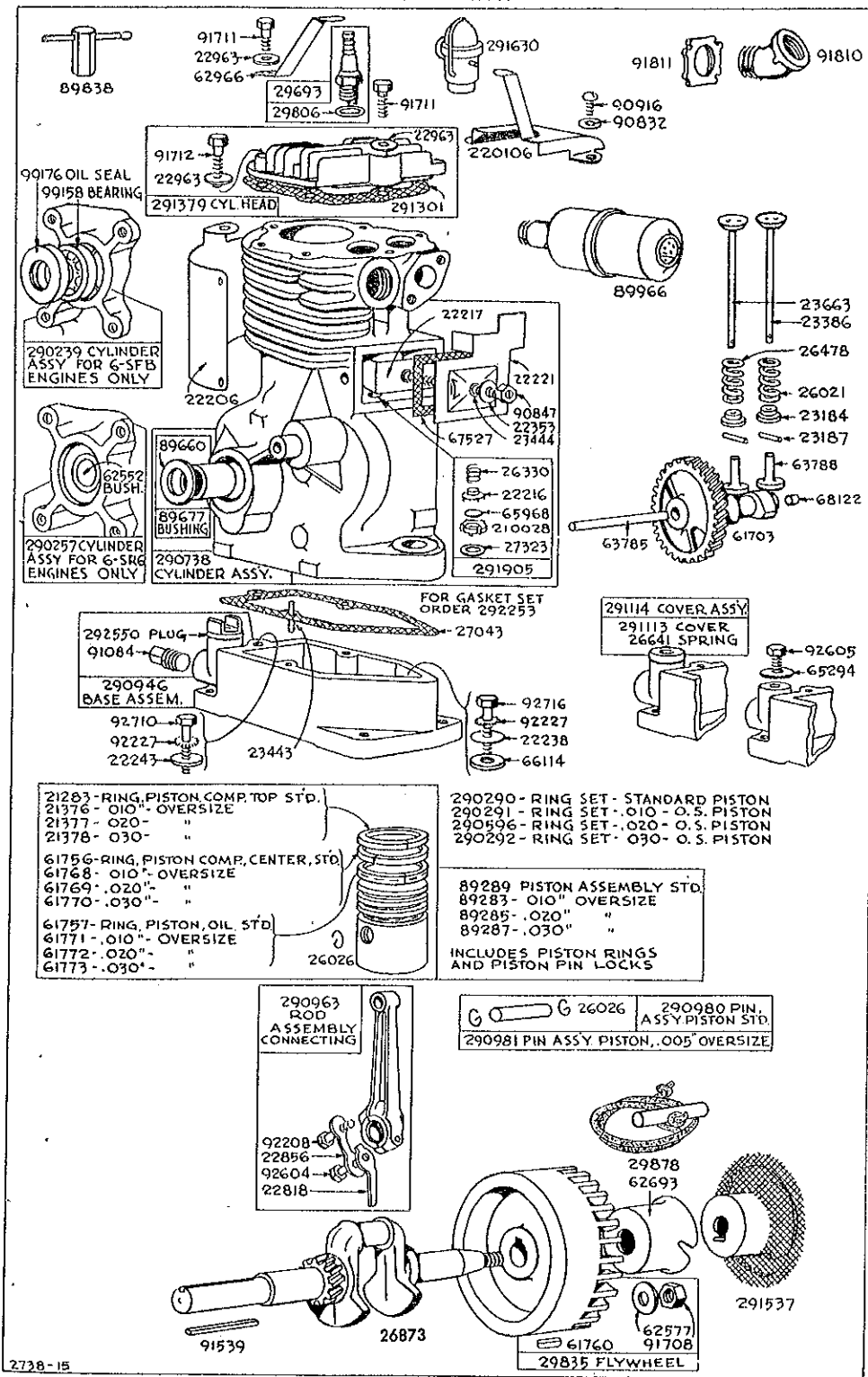

CYLINDER, BASE, PISTON, CONNECTING ROD, CRANKSHAFT AND FLYWHEEL PARTS

Assemblies include all parts shown in frames.

PARTS SECTION

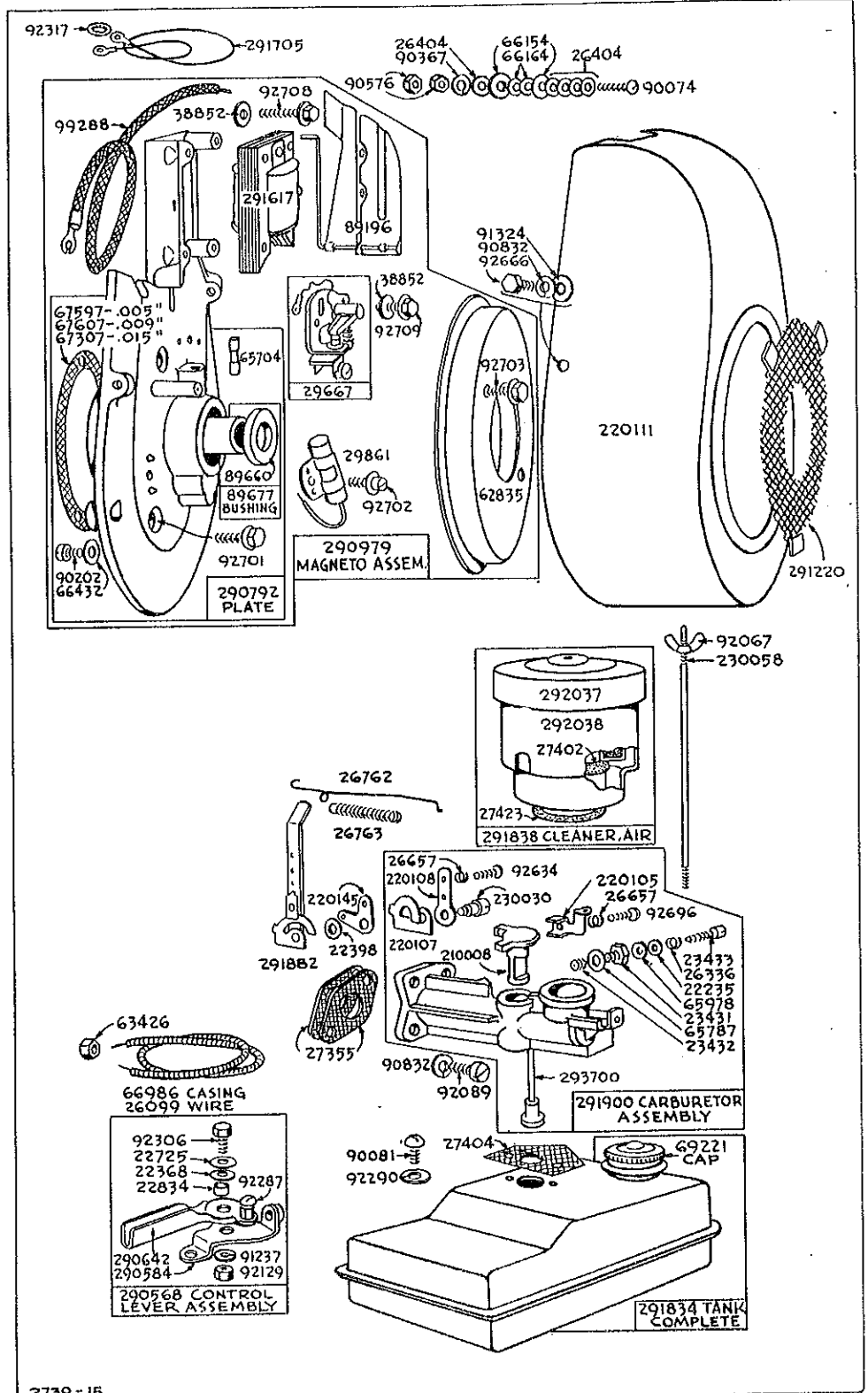

2739-16

FUEL SYSTEM, BLOWER CASE AND MAGNETO PARTS
Assemblies include all parts shown in frames.

PARTS SECTION

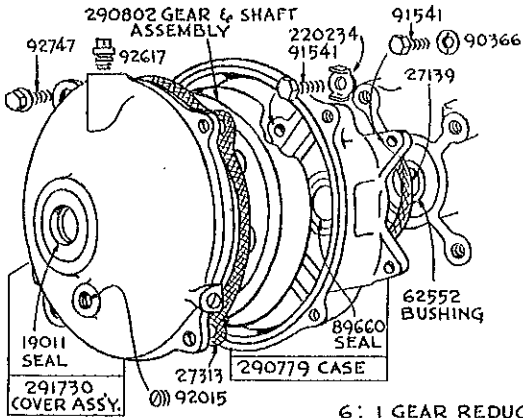

6: 1 GEAR REDUCTION PARTS

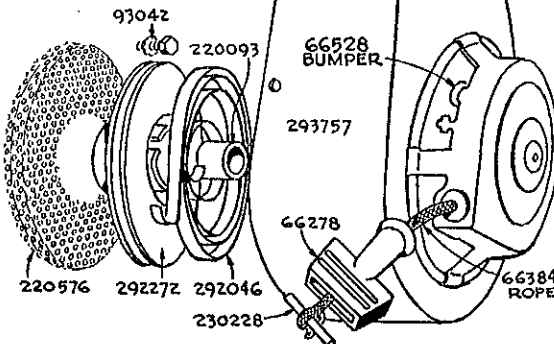
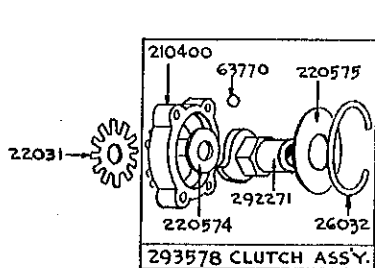
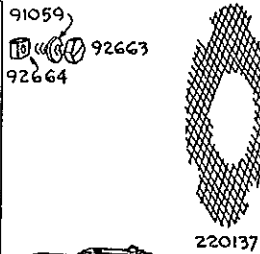
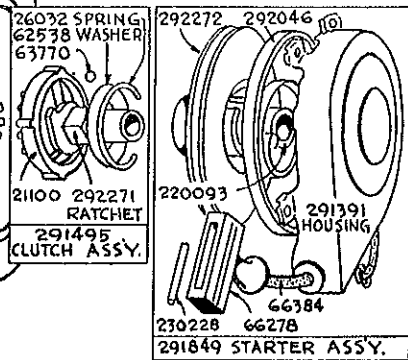
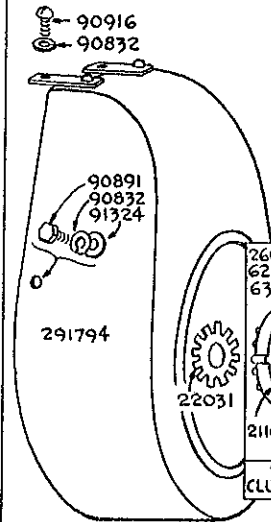
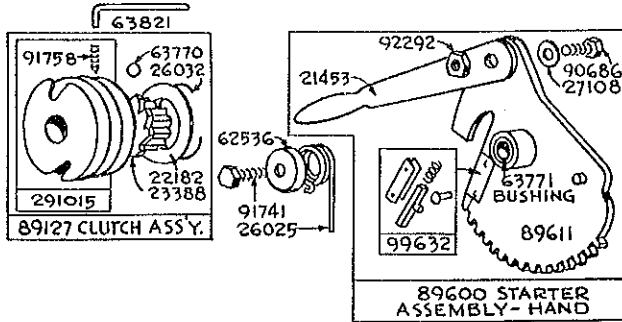

2798-84

GEAR REDUCTION AND STARTER PARTS
 Assemblies include all parts shown in frames.

PARTS SECTION

NUMERICAL PARTS LIST

MASTER PART No.	NAME	SHIPPING WEIGHT	
		Lbs.	Oz.
10011	Seal—Oil		2
21100	Housing—Starter Clutch		10
21283	Ring—Piston, Compression, Top—Standard		1
21370	Ring—Piston, Compression, Top—.010" O.S.		1
21377	Ring—Piston, Compression, Top—.020" O.S.		1
21378	Ring—Piston, Compression, Top—.030" O.S.		1
21453	Lever—Hand Starter	1	
	<i>Note:</i> No. 210094 Lever—Hand Starter		1
	Used on type No. 701302.		
22031	Lock—Clutch Housing		2
22182	Washer—Clutch Retainer		1
22206	Shield—Cylinder		6
22210	Cover—Breather		1
22217	Shield—Oil Spray		1
22221	Cover—Valve		6
	<i>Note:</i> No. 220706 Cover—Valve		6
	Used on type Nos. 701131, 701132.		
	Uses: No. 203869 Tube, Breather		2
22235	Washer—Needle Valve		1
22238	Washer—Cylinder Mounting		1
22243	Washer—Cylinder Mounting		1
*22353	Washer—Valve Cover		1
22368	Washer—Control Lever		1
22398	Washer—Bell Crank		1
22725	Washer—Control Lever		1
22818	Dipper—Connecting Rod		8
22834	Washer—Spacer		1
22856	Lock—Connecting Rod Screw		1
22963	Washer—Cylinder Head		1
23184	Retainer—Valve Spring		1
23187	Pin—Valve Spring Retainer		1
23386	Valve—Intake		2
23388	Pinion—Starter		4
23431	Nut—Needle Valve		1
23432	Seat—Needle Valve		1
23433	Valve—Needle		1
23443	Pin—Dowel		1
23444	Stud—Valve Cover		1
23003	Valve—Exhaust		2
26021	Spring—Intake Valve		1
26025	Spring—Pedal Return		1
26026	Lock—Piston Pin		1
26032	Spring—Clutch Retainer		1
26099	Wire—Control—54" long		2
	<i>Note:</i> If a longer wire is needed, specify length in inches; if a shorter wire is needed order No. 26099 and cut to required length.		
26330	Spring—Breather Retainer		1
26336	Spring—Needle Valve		1
26404	Washer—Terminal		1
26478	Spring—Exhaust Valve		1
26641	Spring—Oil Hole Cover		1
26657	Spring—Speed and Throttle Adjustment Screw		1
26762	Link—Governor		1
26763	Spring—Governor		1
26873	Crankshaft	3	
	<i>Note:</i> No. 26032 Crankshaft		3
	Used on type No. 701504.		
	No. 26099 Crankshaft		3
	Used on type No. 701821.		

(See following page)

* Included in Gasket Set — Part No. 292253.

PARTS SECTION

MASTER PART No.	NAME	SHIPPING WEIGHT	
		Lbs.	Oz.
	No. 26740 Crankshaft		3
	Used on type No. 701046.		
	No. 26897 Crankshaft		3
	Used on type No. 701044.		
	No. 26887 Crankshaft		3
	Used on type Nos. 701023, 701041, 701054.		
	No. 26890 Crankshaft		3
	Used on type No. 701500.		
	No. 26891 Crankshaft		3
	Used on type Nos. 701030, 701037, 701040, 701056, 701077, 701302.		
	No. 26897 Crankshaft		3
	Used on type No. 701066.		
	No. 26942 Crankshaft		3
	Used on type No. 701072.		
	No. 26951 Crankshaft		3
	Used on type Nos. 701014, 701020, 701027, 701034, 701036, 701052, 701055, 701060, 701068, 701069, 701070, 701071, 701074, 701078, 701081, 701086, 701088, 701089, 701091, 701093, 701094, 701095, 701096, 701097, 701098, 701099, 701100, 701102, 701103, 701104, 701106, 701108, 701111, 701115, 701116, 701119, 701129, 701131.		
	No. 26952 Crankshaft		3
	Used on type Nos. 701022, 701064, 701092, 701109.		
	No. 26986 Crankshaft		3
	Used on type Nos. 701083, 701114.		
	No. 260009 Crankshaft		3
	Used on type Nos. 701015, 701031, 701101, 701121, 701130.		
*27048	Gasket—Engine Base		1
27108	Washer—Starter Lever		1
27130	Gasket—Gear Case Mounting		1
27313	Gasket—Gear Case Cover		1
27323	Gasket—Breather Body		1
*27355	Gasket—Carburetor Mounting		1
27402	Gasket—Air Cleaner (Cup Shape)		1
*27404	Gasket—Fuel Tank Mounting		1
27423	Gasket—Air Cleaner		1
	*Note: No. 292252 Gasket Set		1
	Used on engines with plastic bowl air cleaner.		
29007	Breaker Assembly—Ignition		2
29008	Plug—Spark—With Gasket		3
29806	Gasket—Spark Plug		1
29895	Flywheel—Magneto	6	
29801	Condenser		2
29878	Rope—Starter		6
38852	Washer—Armature and Breaker Mounting		1
61703	Gear—Cam	1	
61756	Ring—Piston, Compression, Center—Standard		1
61757	Ring—Piston, Oil—Standard		1
61760	Key—Flywheel		1
61768	Ring—Piston, Compression, Center—.010" O.S.		1
61769	Ring—Piston, Compression, Center—.020" O.S.		1
61770	Ring—Piston, Compression, Center—.030" O.S.		1
61771	Ring—Piston, Oil—.010" O.S.		1
61772	Ring—Piston, Oil—.020" O.S.		1
61773	Ring—Piston, Oil—.030" O.S.		1
62536	Cup—Starter Return Spring		1
62538	Washer—Clutch Retainer		1
62552	Bushing—Cylinder		2
62577	Washer—Flywheel		1
62603	Pulley—Rope Starter		6
62835	Cover—Dust		4
62906	Switch—Stop		2
63426	Locknut—Control Wire Casing		1
63770	Ball—Clutch		1

* Included in Gasket Set — Part No. 292253.

PARTS SECTION

MASTER PART No.	NAME	SHIPPING WEIGHT	
		Lbs.	Oz.
63771	Bushing—Starter		1
63785	Shaft—Cam		3
63788	Tappet—Valve		1
63821	Wrench—Socket Set Screw		2
65204	Washer—Filler Screw		1
65704	Plunger—Breaker Point		1
65787	Gasket—Needle Valve Nut		1
65908	Disk—Breather		1
65978	Packing—Needle Valve		1
*66114	Washer—Cylinder Mounting		1
66154	Washer—Terminal		1
66164	Washer—Terminal		1
66278	Grip—Starter Rope		2
66384	Rope—Starter ($\frac{1}{8}$ " Dia.)		1
	Note: No. 66334 Rope—Starter ($\frac{1}{8}$ " Dia.)		1
	Used on earlier model engines.		
66432	Washer—Casing Retainer		1
66528	Bumper—Starter Pulley		1
66986	Casing—Control Wire—48" long		8
	Note: If a longer casing is needed, specify length in inches; if a shorter casing is needed order No. 66986 and cut to required length.		
*67307	Gasket—Magneto Plate—.015" thick		1
*67527	Gasket—Valve Cover		1
*67597	Gasket—Magneto Plate—.005" thick		1
*67607	Gasket—Magneto Plate—.009" thick		1
68122	Plug—Cam Shaft		1
69221	Cap—Fuel Tank		2
89127	Clutch Assembly—Starter	1	
89196	Blade Assembly—Governor		2
89283	Piston Assembly—.010" O.S.		8
89285	Piston Assembly—.020" O.S.		8
89287	Piston Assembly—.030" O.S.		8
89289	Piston Assembly—Standard		8
89600	Starter Assembly—Hand Lever		3
	Note: No. 291497 Starter Assembly—Hand Lever		3
	Used on type No. 701302.		
89611	Sector Assembly—Starter		14
	Note: No. 290331 Sector Assembly—Starter		14
	Used on type No. 701302.		
	Uses: No. 23756 Pin—Starter Lever		1
89600	Seal—Oil		1
89677	Bushing—Cylinder or Magneto		3
	Includes: No. 89600 Seal—Oil.		
89838	Wrench—Spark Plug		6
89966	Muffler		8
	Note: No. 292054 Muffler		6
	Used on type Nos. 701015, 701016, 701019, 701022, 701023, 701027, 701028, 701041, 701046, 701047, 701054, 701055, 701056, 701060, 701062, 701064, 701067, 701070, 701071, 701072, 701082, 701086, 701091, 701092, 701098, 701103, 701109, 701110, 701112, 701120, 701127, 701130, 701302.		
90074	Screw—Machine, Rd. Hd.—8-32x $\frac{3}{4}$ "		1
90081	Screw—Machine, Round Hd.—10-32x $\frac{1}{2}$ "		1
90202	Screw—Machine, Fill. Hd.—10-32x $\frac{1}{2}$ "		1
90306	Washer—Lock— $\frac{1}{8}$ x $\frac{1}{2}$ x $\frac{1}{8}$ "		1
90307	Washer—Lock—No. 8x $\frac{1}{2}$ x $\frac{1}{4}$ "		1
90570	Nut—Hex.—8-32		1
90686	Screw—Cap, Hex. Hd.— $\frac{3}{8}$ -24x1"		1
90882	Washer—Lock— $\frac{1}{4}$ x $\frac{3}{4}$ x $\frac{1}{8}$ "		1
90847	Nut—Hex.— $\frac{1}{4}$ -28		1
90891	Screw—Cap, Hex. Hd.— $\frac{1}{4}$ -20x $\frac{1}{2}$ " (Use No. 92666)		1
90916	Screw—Machine, Round Hd.— $\frac{1}{4}$ -24x $\frac{1}{2}$ "		1

* Included in Gasket Set — Part No. 292253.

PARTS SECTION

MASTER PART No.	NAME	SHIPPING WEIGHT	
		Lbs.	Oz.
91059	Washer—Lock—No. 12x $\frac{1}{2}$ x $\frac{1}{4}$ "		1
91084	Plug—Pipe— $\frac{3}{8}$ "		1
91237	Washer—Lock— $\frac{1}{4}$ x $\frac{1}{2}$ x $\frac{1}{4}$ "		1
91324	Washer— $\frac{1}{4}$ " Standard		1
91539	Key—Crankshaft		1
91541	Screw—Cap, Hex. Hd.— $\frac{3}{8}$ -24x $\frac{1}{2}$ "		1
91708	Nut—Flywheel		1
91711	Screw—Cylinder Head (1" long)		1
	Note: { No. 93423 Spacer—Cylinder Head		1
	{ No. 92909 Screw—Cylinder Head (1 $\frac{1}{2}$ " long)		1
	Used on type Nos. 701032, 701036, 701102, 701128, 701129.		1
91712	Screw—Cylinder Head (1 $\frac{1}{4}$ " long)		1
91741	Screw—Pedal Return Spring Cup		1
91758	Screw—Set, Socket Hd.— $\frac{1}{8}$ -24x $\frac{1}{2}$ "		3
91810	Elbow—Exhaust (45° Street)		4
	Note: No. 91812 Elbow—Exhaust (90° Street)		
	Used on type Nos. 701039, 701061, 701075, 701085, 701107, 701113, 701115.		2
91811	Locknut—Muffler Elbow		1
92015	Plug—Oil Drain (Gear Cover)		1
92067	Nut—Wing		1
92089	Screw—Machine, Fill. Hd.— $\frac{1}{4}$ -20x $\frac{3}{4}$ "		1
92120	Nut—Hex.— $\frac{1}{4}$ -28		1
92208	Screw—Connecting Rod		1
92227	Washer—Lock—Shakeproof No. 1320		1
92287	Screw—Machine, Round Hd.—10-32x $\frac{1}{4}$ "		1
92290	Washer—Lock—No. 10x $\frac{1}{2}$ x $\frac{1}{4}$ "		1
92292	Nut—Hex.— $\frac{3}{8}$ -24		1
92306	Screw—Cap, Hex. Hd.— $\frac{1}{4}$ -28x $\frac{3}{4}$ "		1
92317	Washer—Lock—Shakeproof No. 1208		1
92604	Screw—Connecting Rod		1
92605	Screw—Oil Filler		2
92617	Plug—Breather		1
92634	Screw—Machine, Rd. Hd.—5-40x $\frac{1}{2}$ "		1
92663	Screw—Starter Mounting		1
92664	Nut—Starter Mounting		1
92666	Screw—Cap, Hex. Hd.— $\frac{1}{4}$ -20x $\frac{1}{2}$ "		1
92696	Screw—Machine, Rd. Hd.—5-40x $\frac{1}{2}$ "		1
92701	Screw—Magneto Mounting Sem		1
	Note: No. 90832 Washer—Lock— $\frac{1}{4}$ x $\frac{1}{2}$ x $\frac{1}{4}$ "		
	Used on earlier model engines.		1
92702	Screw—Condenser Mounting Sem		1
	Note: No. 90367 Washer—Lock—No. 8x $\frac{1}{2}$ x $\frac{1}{4}$ "		
	Used on earlier model engines.		1
92703	Screw—Dust Cover Mounting Sem		1
	Note: No. 90367 Washer—Lock—No. 8x $\frac{1}{2}$ x $\frac{1}{4}$ "		
	Used on earlier model engines.		1
92708	Screw—Armature Mounting Sem		1
	Note: No. 92317 Washer—Lock—Shakeproof No. 1208		
	Used on earlier model engines.		1
92709	Screw—Breaker Mounting Sem		1
	Note: No. 92317 Washer—Lock—Shakeproof No. 1208		
	Used on earlier model engines.		1
92710	Screw—Cylinder Mounting—1 $\frac{1}{2}$ " Long (Washer Hd.)		1
	Note: No. 92235 Screw—Cylinder Mounting—1 $\frac{1}{2}$ " Long (Slotted Hd.)		
	Used on engines before Serial No. 147955.		1
92716	Screw—Cylinder Mounting (Washer Hd.)		1
	Note: No. 92236 Screw—Cylinder Mounting		
	Used on engines before Serial No. 147955.		1
92747	Screw—Gear Case Cover Mounting Sem		1
93042	Screw—Rotating Screen Mounting Sem		8
99158	Bearing—Ball (Used on model 6-SFB engines only)		

PARTS SECTION

MASTER PART No.	NAME	SHIPPING WEIGHT	
		Lbs.	Oz.
99170	Seal—Oil (Used on model 6-SFB engines only).....		3
99288	Cable—Ignition		2
	Note: No. 292187 Cable—Ignition		2
	Used on type No. 701048.		
99632	Tooth Assembly—Spring		1
210008	Throttle—Carburetor		1
	Note: No. 210088 Throttle—Carburetor		1
	Used on type Nos. 701302, 701821.		
210028	Body—Breather		1
210400	Housing—Starter Clutch	1	
220093	Retainer—Spring		1
220105	Connector—Governor Link		1
220106	Cover—Cylinder Head		1
220107	Cam—Speed Adjuster		1
220108	Lever—Speed Adjuster		1
220111	Housing—Blower	1	
	Note: No. 22889 Housing—Blower	1	
	Used on type No. 701026.		
220187	Screen—Blower Housing (Used on engines with bolt-on recoil starter).....		2
220145	Crank—Bell		1
220234	Lock—Gear Case Mounting Screw		1
220574	Washer—Starter Clutch Thrust.....		1
220575	Washer—Clutch Retainer		1
220576	Screen—Recoil Starter		2
230030	Screw—Carburetor Cam and Lever		1
230058	Stud—Air Cleaner		2
230228	Pin—Starter Grip		1
290239	Cylinder Assembly (Used on model 6-SFB engines only).....	14	
290257	Cylinder Assembly (Used on model 6-SR6 engines only).....	14	
290290	Ring Set—Standard Piston		8
290291	Ring Set—.101" O.S. Piston		8
290292	Ring Set—.030" O.S. Piston		8
290568	Lever Assembly—Control		4
290584	Base—Control Lever		2
290590	Ring Set—.020" O.S. Piston		8
290642	Lever—Control		2
290738	Cylinder Assembly	14	
	Note: This group of cylinders including part No. 290738 used on Model 6-S engines only. (For Model 6-SFB engines see part No. 290239; for Model 6-SR6 engines see part No. 290257.)		
	No. 89465 Cylinder Assembly	14	
	Used on type Nos. 701012, 701019, 701027, 701047, 701055, 701062, 701063, 701067, 701068, 701079, 701080, 701081, 701086, 701088, 701095, 701096, 701098, 701115, 701116, 701124.		
	No. 292268 Cylinder	14	
	Used on type Nos. 701054, 701064.		
	No. 293058 Cylinder Assembly	14	
	Used on type Nos. 701069, 701073, 701094.		
290779	Case Assembly—Gear	1	8
290792	Plate—Magneto	2	
	Note: No. 290809 Plate—Magneto	2	
	Used on type Nos. 701051, 701078, 701117.		
290802	Shaft Assembly—Drive	3	8
290946	Base Assembly—Engine	1	8
	Note: No. 290938 Base Assembly—Engine	1	10
	Used on type Nos. 701049, 701050, 701072, 701075, 701076, 701085, 701105, 701106, 701107, 701123.		
290963	Rod Assembly—Connecting		12
290979	Magneto Assembly	6	
	Note: No. 291199 Magneto Assembly	6	

(See following page)

PARTS SECTION

MASTER PART No.	NAME	SHIPPING WEIGHT	
		Lbs.	Oz.
	Used on type Nos. 701051, 701078, 701117. Includes: No. 60155 Wire—Ground		1
	No. 292130 Magneto Assembly	6	
	Used on type Nos. 701045, 701097, 701125. Includes: No. 292042 Wire—Ground		1
	No. 292206 Magneto Assembly	6	
	Used on type No. 701048.		
290080	Pin Assembly—Piston—Standard		2
290981	Pin Assembly—Piston—.005" O.S.		2
291015	Housing—Starter Clutch		10
	Note: No. 61973 Pulley	1	
	Used on type No. 701057.		
291113	Cover—Oil Hole		2
291114	Cover Assembly—Oil Hole		2
291220	Screen—Blower Housing		2
	Note: No. 291430 Screen—Blower Housing (Full Screen)		2
	Used on type No. 701302.		
291301	Gasket—Cylinder Head		1
	Note: *No. 67537 Gasket—Cylinder Head (1/4" thick)		1
	Used with cylinder heads having seven fins.		
291379	Head Assembly—Cylinder	1	8
291391	Housing—Starter		12
291495	Clutch Assembly—Starter	1	
291537	Screen Assembly—Rotating		8
291617	Armature—Magneto	1	2
291630	Shield—Spark Plug		6
291705	Wire—Ground—53 1/2" Long		2
291730	Cover Assembly—Gear Case	1	4
291794	Housing—Blower (Used on engines with bolt-on recoil starter)	1	4
	Note: No. 291706 Housing—Blower	1	4
	Used on type No. 701052.		
291834	Tank Assembly—Fuel	1	4
291888	Cleaner Assembly—Air	1	
291849	Starter Assembly—Recoil (bolt-on type)	2	
291882	Control—Governor		1
291900	Carburetor Assembly	1	
	Note: No. 291902 Carburetor Assembly	1	
	Used on type Nos. 701017, 701038, 701048, 701066, 701067, 701072, 701085.		
	No. 291957 Carburetor Assembly	1	
	Used on type Nos. 701022, 701023, 701033, 701041, 701050, 701054, 701064, 701071, 701092, 701103, 701109, 701111.		
	No. 292172 Carburetor Assembly	1	
	Used on type No. 701302.		
	No. 292174 Carburetor Assembly	1	
	Used on type No. 701821.		
291905	Breather Assembly		3
292037	Cover and Filter—Air Cleaner		8
292038	Bowl—Air Cleaner		6
292046	Spring—Starter		5
292253	Gasket Set		4
292271	Ratchet—Recoil Starter		5
292272	Pulley—Recoil Starter	1	
292550	Plug—Oil Filler		1
293578	Clutch Assembly—Recoil Starter	1	8
293700	Pipe—Fuel		1
293757	Housing—Blower and Recoil Starter	2	
	Note: No. 293772 Housing—Blower and Recoil Starter	2	
	Used on type No. 701099.		
	No. 294081 Housing—Blower and Recoil Starter	2	
	Used on type No. 701125.		

* Included in Gasket Set — Part No. 292253.

NATION-WIDE SERVICE ORGANIZATION

To provide prompt and efficient service on Briggs & Stratton engines, Authorized Service Distributors and Engine Service Stations are located in the principal cities of the United States and Canada.

Each Authorized Service Organization carries a stock of original Briggs & Stratton repair parts. Each is equipped with special factory service tools and factory-trained mechanics, assuring expert repair service on all Briggs & Stratton engines.

All Authorized Service Organizations are instructed by the factory to replace free of charge all parts found to be defective in either material or workmanship, according to the conditions of the Briggs & Stratton Warranty.

All gratis work done under the warranty is the responsibility of the Authorized Service Organization until all the material involved and supporting facts are submitted to and approved by the factory.

In a difference of opinion regarding a Service Organization's decision, their terms should be accepted and, either through them or direct, have all materials and supporting facts submitted to the factory for review.

Genuine Briggs & Stratton service will assure continuous engine satisfaction. Our long experience in engine maintenance prompts us to urge that all service work be done by an Authorized Service Organization or at our factory. Mechanics unfamiliar with Briggs & Stratton products, or without proper tools, should not be permitted to make major repairs.

Parts and repair work are F. O. B. Factory or any member of Authorized Briggs & Stratton Service Organization. The Service Distributor nearest you (see back cover page) will be glad to give you the name of our Engine Service Organization in your locality. Space does not permit listing here.

BRIGGS & STRATTON ENGINE WARRANTY

BE SURE TO FILL IN AND MAIL WARRANTY REGISTRATION CARD WHICH ACCOMPANIED ENGINE AT TIME OF PURCHASE

THE WARRANTY—For Ninety Days from purchase date, Briggs & Stratton Corporation will replace for the original purchaser, **FREE OF CHARGE**, any part or parts found, upon examination at any factory Authorized Service Distributor or at our factory at Milwaukee, Wisconsin, or at any Authorized Service Distributor's place of business, to be defective under normal use and service, on account of defects in material or workmanship.

All transportation charges on part or parts submitted for replacement under this warranty must be borne by purchaser.

WHAT THIS WARRANTY DOES NOT INCLUDE—This warranty does not cover the free replacement of parts inoperative because of wear occasioned by use. It does not cover the labor cost of replacing parts, neither is it effective if the engine has been the subject of misuse, negligence, or accident, nor if it has been repaired or altered, outside of our Milwaukee Factory or at any factory-approved Service Station, in any way which, in our judgment, affects its condition or operation.

WARRANTY INSTRUCTIONS

When sending an engine, or engine parts, to a Briggs & Stratton Service Organization for service, at the same time always send by mail the following information:

Model Letter (or Number), Type Number, and Serial Number of the engine. (Take from metal plate on engine.)

Date purchased.

Kind of equipment engine is used on.

Name or trademark of manufacturer.

Name and address of dealer from whom purchased.

Approximate number of hours engine has run since equipment was bought.

Also, give complete report of trouble experienced and special servicing instructions.

The above information is necessary to insure prompt and proper service.

AUTHORIZED SERVICE ORGANIZATION

There is a member of the Briggs & Stratton Service Organization in your neighborhood who is fully qualified to take care of your service needs. Space does not permit listing here, but if you will write to the nearest distributor listed below, they will be glad to supply you with name and address.

STATE	CITY	NAME	LOCATION
Alabama	Birmingham 3	Birmingham Electric Battery Co.	Ave. B. at 23rd St.
Arizona	Phoenix	Motor Supply Co.	402-414 N. Central Ave.
California	Los Angeles 15	Electric Equipment Co.	1611 S. Hope St.
California	San Francisco 9	Frank Edwards Co., Automotive Service Div.	382-4 Sixth St.
Colorado	Denver 1	Spitzer Electric Company	43 W. 9th Ave.
Florida	Jacksonville 1	Spencer Electric, Inc.	40 W. Beaver St.
Florida	Miami 42	Electric Equipment Co.	1415 N.W. 21st Terrace
Florida	Tampa 1	Spencer Auto Electric, Inc.	607-11 E. Cass St.
Georgia	Atlanta 3	Auto Electric & Magneto Co.	477 Spring St., N. W.
Illinois	Chicago 16	Mid-States Auto Electric Co.	1905 S. Michigan Ave.
Indiana	Indianapolis 4	Gulling Auto Electric Co.	450 N. Capitol Ave.
Iowa	Des Moines 9	Magneto Carburetor & Electric Co., Inc.	1308 Grand Ave.
Kansas	Wichita 2	The E. S. Cowie Electric Co.	230 S. Topeka Ave.
Kentucky	Louisville 2	Kentucky Ignition Co., Inc.	737 S. 3rd St.
Louisiana	New Orleans 1	A. C. Suhren Co.	4640 So. Carrollton Ave.
Louisiana	Shreveport	Chain Battery & Automotive Supply, Inc.	Spring at Pannin St.
Massachusetts	Boston 64	W. J. Connell Co.	210 Needham St.
Michigan	Detroit 38	Auto Electric & Service Corp.	15550 Woodrow Wilson Ave.
Minnesota	Minneapolis 2	Reinhard Brothers Co., Inc.	11 S. Ninth St.
Missouri	Kansas City 8	The E. S. Cowie Electric Co.	1819 Wyandotte St.
Missouri	St. Louis 3	Medart Auto Electric Co., Inc.	3134 Washington Blvd.
Montana	Billings	Original Equipment, Inc.	423 N. Broadway
Nebraska	Omaha 2	Carl A. Anderson, Inc.	16th and Jones St.
New Mexico	Albuquerque	Spitzer Electrical Co. of New Mexico	3rd and Mountain Rd.
New York	Buffalo 14	The Battery & Starter Co., Inc.	2505 Main St.
New York	New York 19	The Durham Co., Inc.	606 W. 49th St.
New York	Syracuse 4	F. A. Crossman, Inc.	943 W. Genesee St.
North Carolina	Charlotte 1	Automotive Electric Associates, Inc.	306-14 N. Graham St.
North Dakota	Fargo	Reinhard Brothers Co., Inc.	301 N. Pacific Ave.
Ohio	Cincinnati 2	Gardner, Inc.	1847 Reading Rd.
Ohio	Cleveland 15	The Electric Power & Maintenance Co.	Prospect at East 30th
Ohio	Toledo 2	Electric Power & Maintenance Co.	26-30 Seventeenth St.
Oklahoma	Oklahoma City 2	American Electric Ignition Co.	124 N. W. 8th St.
Oregon	Portland 9	Tracey & Co., Inc.	N. W. 10th and Gibson
Pennsylvania	Philadelphia 30	Auto Equipment & Service Co., Inc.	1522-24 Fairmount Ave.
Pennsylvania	Pittsburgh 24	Pitt Auto Electric Company	5135 Baum Blvd.
South Dakota	Sioux Falls	Reinhard Brothers Co.	225 E. 11th St.
Tennessee	Knoxville 7	R. T. Clapp Company	2016 Magnolia Ave., N.E.
Tennessee	Memphis 4	Automotive Electric Service Co.	982 Linden Ave.
Texas	Amarillo	The E. S. Cowie Electric Co.	700 E. 10th St.
Texas	Dallas 1	Beard & Stone Electric Company, Inc.	3909 Live Oak St.
Texas	El Paso	Motor Supply Co.	308 Chihuahua St.
Texas	Houston 1	Beard & Stone Electric Company, Inc.	Milam at Polk Ave.
Texas	San Antonio 6	S. X. Callahan	425 N. Flores St.
Utah	Salt Lake City 13	Frank Edwards Co., Motor Equipment Div.	551 So. State St.
Virginia	Richmond 21	Richmond Battery & Ignition Co.	2912 W. Leigh St.
Washington	Seattle 4	Charles Stewart, Inc.	1741 First Ave. South
Washington	Spokane	Sunset Electric Co.	N. 703 Division St.
Wisconsin	Milwaukee 2	Wisconsin Magneto Co.	918 N. Broadway

DOMINION OF CANADA

British Columbia	Vancouver	Auto Electric Service (Pacific) Ltd.	1025 Howe St.
Manitoba	Winnipeg	Auto Electric Service (Western) Ltd.	176 Fort St.
Ontario	Toronto 5	Auto Electric Service Company, Limited	1009 Bay St.

BRIGGS & STRATTON CORP., Milwaukee 1, Wis., U.S.A.