

PA 700S

OPERATOR'S MANUAL



PA-700S

If any mixing unit is to be compatible with a wide variety of input signals it must have the capability to control the sensitivity of each channel. This requires an **INPUT ATTENUATOR** (1) sometimes referred to as an input pad. Some mics and signal sources can be at such a level as to overdrive or clip the input circuitry of a mixer. An input attenuator allows the operator to reduce the input gain when input clipping occurs. Some manufacturers put attenuators in their snake or stage box to be able to control the sensitivity of the mic or signal source. This is not the best approach if you are sending your signals through cable runs of any length. Many times it would be impossible to make an adjustment on one of the attenuators if necessary during the performance. You shouldn't have to run up to the stage and pick up the drummer's leg so you can adjust a mic input!

In use, the operator must adjust the input attenuator in such a manner that input clipping is avoided. This can easily be done by setting up the channel with the highest expected input signal level and adjusting the input attenuator so that no clipping or distortion is heard from the speaker system. After the mixer has been used several times, the operator will have a very good idea of the signal levels encountered and will be able to set up the attenuators accordingly. The different types of microphones will have different output levels and different performers will get widely varying levels from mics depending on the strength of their voices and/or their basic "mic techniques".

The input attenuator should be operated in the position yielding the least attenuation required to avoid clipping. Operation in this mode allows maximum gain to be utilized in the input preamp where it is most efficiently obtained. Excessive input padding sometimes makes necessary higher settings of the channel gain controls and/or master control thus yielding a less than optimum signal-to-noise ratio for any given situation.

It is important to realize that not all "break-up" is caused by the mic signal overloading the input stage of the mixer. If the performer's mic technique includes very close and/or very loud situations, the internal elements of the mic can "bottom out" or distort just as a loudspeaker can when it is overdriven. Quite a few of the mics now used by performers lack the dynamic range required to adequately handle the tremendous sound pressure levels encountered in a very loud rock and roll concert situation. It is vital for the

professional soundman and the musicians to be aware of the limitations of the various links in the audio system in order to correctly diagnose and solve the various problems encountered in a sound reinforcement situation.

Overall, the input attenuator is the first control in the circuit and must be set up properly in order for the remaining circuits to function properly. "Common sense" and experience operating the PA 700S on several jobs will allow the

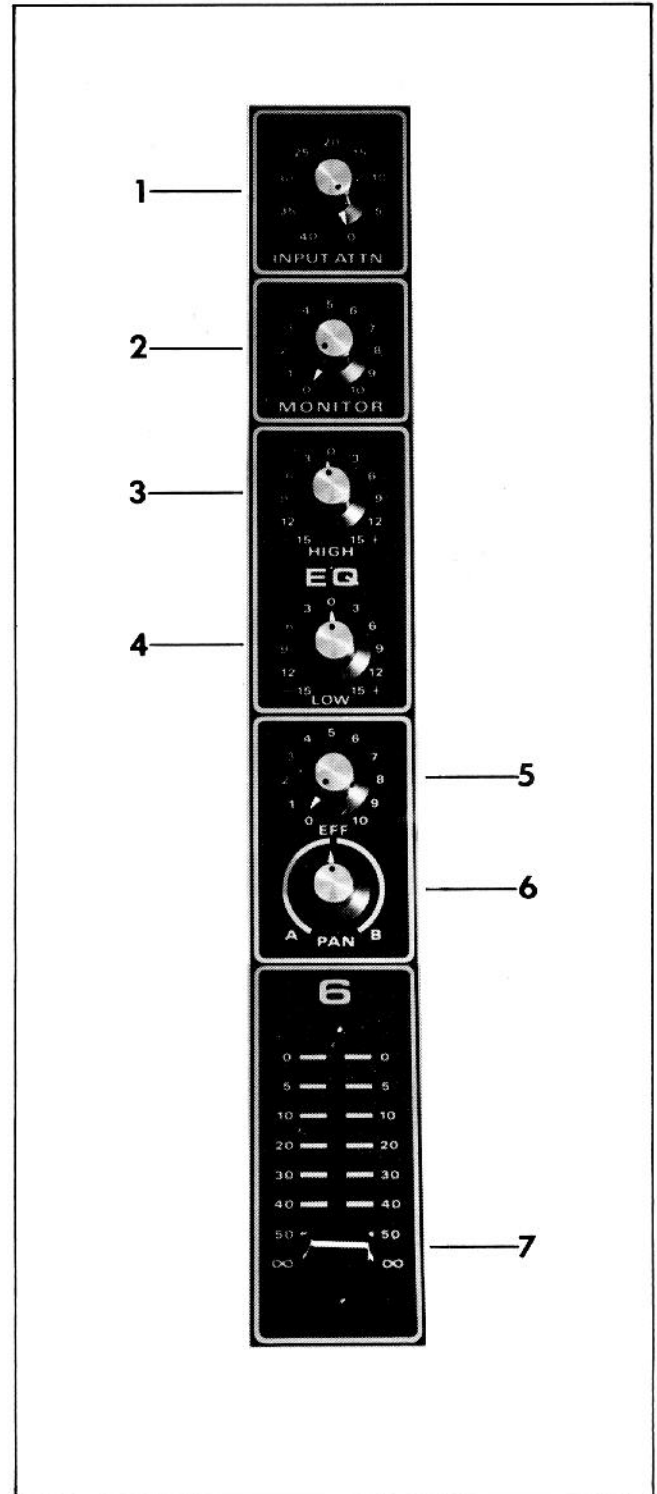

operator to achieve superb results in virtually any mixing situation. Our variable input attenuator allows for much more flexibility than some other manufacturer's mixers that only have switchable fixed attenuation of maybe 10 to 20 dB, where sometimes 10 dB may not be enough and 20 dB may be too much attenuation. The PA 700S's input attenuator is continuously variable from 0 dB to -40 dB.

The **MONITOR SEND CONTROL** (2) is the channel mixing element for determining the important monitor mix. The signal for the monitor send is obtained right after the input preamp and before the channel EQ. This is referred to as a Monitor Pre-send Control, i.e., it is before or pre to the channel equalization and slider level control. This makes it independent of these controls, meaning that any changes made to the EQ or channel level will not affect the monitor system. Having the monitor send with the pre capability is absolutely vital to avoid feedback of the monitor system when EQ and normal incremental output variations are made in the channel fader during the course of the performance.

The equalization circuitry of the PA 700S is the latest active type, utilizing negative feedback technology. We selected circuitry that produces a "shelving" type of action because the conventional type circuitry used by some manufacturers tends to create erratic or sometimes harsh sounding results when in the near-maximum boost positions. These two equalization controls will produce extremely smooth action as well as giving effective tone control. Experience will show their utility in achieving professional channel equalization on the job.

It should be remembered that these active equalization circuits are a form of "electronic crossover" in which the equalization controls are similar to level controls for their respective frequency bands.

Generally, it is poor operating practice to use both equalizer controls in the deep cut (counter-clockwise) positions since this results in substantially lower gain from the channel. It should be remembered that the balance of highs and lows is a relative situation, and cutting overall channel gain should properly be done by the output slide attenuator or input attenuator.

The **LOW FREQUENCY EQUALIZER** (4) is capable of better than 15 dB boost or cut @ 100 Hz with a sloping characteristic exhibited up to the crossover point. The shelving action of this control has proven to yield a much more satisfying and effective equalization characteristic than some of the "wide open" equalization circuits claiming 20 - 25 dB boost and cut. The action of this equalization control is conventional and should present no problem in operation. Boost is obtained in the righthand (clockwise) position while cut is obtained in the lefthand (counter-clockwise) position. The vertical (12 o'clock) position yields a flat (no boost or cut) response and is the position from which all tonal balancing should be started.

The **HIGH FREQUENCY EQUALIZER** (3) is capable of 15 dB boost or cut @ 5 kHz with a shelving characteristic sloping down to the crossover point. The boost or cut action of this control is very similar to that of the low equalizer with the exception of its high frequency effect. Boost is obtained to the right of center position while cut is obtained to the left of the center position. Flat response is obtained in the center (12 o'clock) position.

Caution should be exercised in using extreme low-frequency boost to avoid emphasizing objectionable wind noises or rumble from the microphone as well as any hum that might enter the mixer from external sources. Excessive treble boost should be avoided to keep residual noise from the amplification circuitry to reasonable level as well as to avoid a strident or screeching tonality in the output program material.

The **EFFECTS SEND CONTROL** (5) is the channel level for determining the amount of signal from each respective channel to be sent to the effects output or to be mixed into the reverb summing buss. The effects send circuit has been designed to provide multiple functions which will be explained further in the master control section.

The **STEREO PAN** (6) is the control used to achieve the desired balance from each individual channel into the A and B main output mixing busses. The Pan control may be thought of as a kind of balance control determining the signal sent to either of the stereo outputs of the PA 700S. This Pan control is present on all professional multi-channel mixers, and is useful in achieving many special effects in sound reinforcement as well as being absolutely necessary in stereo tape recording. Again, experimentation and "hands on" experience with the PA 700S are key factors in the use of the Pan control. The Pan is capable of assigning the channel output to either A or B main channels or any combination in between. It is important to remember that the Pan control follows (post) the channel output fader.

The **CHANNEL ATTENUATOR SLIDER** (7) is the output level control that determines the mix into the main summing buss. Its calibration is in decibels of attenuation and this is why the numbering sequence goes from off (infinity = ∞), or maximum attenuation to zero (0), or no attenuation. Remember that attenuation is the cutting or reduction of the signal level, i.e., the more attenuation, the more you have cut down the signal level. The output fader is calibrated in accordance with standard practice for professional audio equipment.

Proper setting of the input attenuator (pad) should produce adequate gain within the input preamp to allow slider settings approximately in the center (approximately -40 to -20 dB). You should remember that the input attenuator is a kind of pre gain control and its settings will most definitely influence the settings for the output slider with any given input signal. The input attenuator should be adjusted for the maximum gain that will allow distortion free performance, then the output slider level should be adjusted for proper mix.

It is very poor operating practice to use the input pads in the extreme cut positions and then have to set the output sliders in their close to maximum positions to obtain adequate channel output. This type of operation results in less than optimum signal-to-noise ratios as well as contributing to headroom problems. As with any system, "common sense" must be combined with operating knowledge to produce satisfactory results. Overall, the channel controls should be set to provide a reasonable amount of "adjustment", i.e., none of the gain controlling elements (input attenuator/output slider) should be operated near their extreme up or down positions. After several hours usage, the operator will have acquired a good "feel" for the characteristics of the controls and should be able to suitably handle any mixdown situation encountered in the field with satisfactory results.

The master area of the PA 700S contains all the master or final output controls for the mixing busses. The main mixing buss equalization features shelving type high and low EQ. The Effects level is the master control for the effects mixing buss.

The master level controls (8) (9) (10) of the PA 700S should be set in such a manner that they are close to the center of their travel to take advantage of maximum control action. It is poor practice to run the channel faders up near maximum and then run the main faders near the low end to achieve the desired output levels. Operation in this manner will cause the operator to lose his "range" in control action with all the gain located in one element while the other is near its stop position. Best practice calls for most controls to be operated in their middle or slightly higher positions to allow maximum mixing control margins (travel). Remember, when mixing, you MUST allow yourself adequate margins within which to operate and by using any of the faders in their extreme (close to stop) positions, you have effectively reduced your range of control. This manner of operation also tends to create "headroom" problems.

These master controls allow the operator complete flexibility of functions and should allow almost any mixing situation to be handled by the PA 700S. As with any reasonably complex system, experience and operator knowledge of the equipment are essential for satisfactory performance. The mixer, like the musician's instrument, should be practiced on and learned. To properly operate a mixer during a performance requires thorough knowledge and trained reflexes to allow proper responses under the stress of demanding and sometimes sudden situations. The musician should know his mixer almost as well as he knows his instrument, so that his reactions will be both smooth and proper to correct whatever problem or requirement that should arise during a performance...a professional must work at it!

The **MASTER OUTPUT FADERS** (8) (9) are the controls that determine the main output level for the output connectors located on the rear panel and to the internal power amplifiers. The main summing amps, as well as the other summing busses, are of the very latest "zero null" type using negative feedback to achieve maximum dynamic range, lowest noise, and crosstalk. The master faders should be operated in accord with the proper operating practices as outlined above. Experimentation and experience on several jobs will allow the operator to achieve a "feel" for the right settings for his requirements.

The **EFFECTS RETURN** (13) is the gain control for the effects return jack located on the rear panel. This effects return input enables the signal from an external source to be mixed back into the main (A and B) mixing busses. This Effects return is similar to an auxiliary input and actually may be used as such. This feature is intended to be used with effects or other devices that are used in conjunction with the effects output, and the signal return from the external unit should be brought into the effects return whose level is controlled by the Effects Return Control.

The **EFFECTS PAN** (14) is the control that enables the operator to place the signal from the effects level return control on either, both, or any combination in between the A and B main channels. This panning capability MUST be present to retain true stereo capability for the PA 700S. The action of this pan control is similar to those on the individual channels and should present no problem in operation.

The **EFFECTS LEVEL** (15) is the control that determines the overall signal output level for the effects send buss. This effects buss has two output connectors associated with it, one is a high level output that can be used to drive a power amplifier for an additional monitor system and the other is a low level output designed to drive the input of an effects device such as an echo unit, phasor, digital delay line, etc. In addition to driving the high and low level effects outputs, the effects level control also determines the drive to the internal reverb delay lines. This effects level control must be adjusted so that the output level from the jack on the rear panel does not overload the input circuitry of the effects unit you are driving, thus causing clipping or other forms of distortion. This is especially critical on some of the special effects units that are designed to work with guitars or other instruments with relatively low output levels.

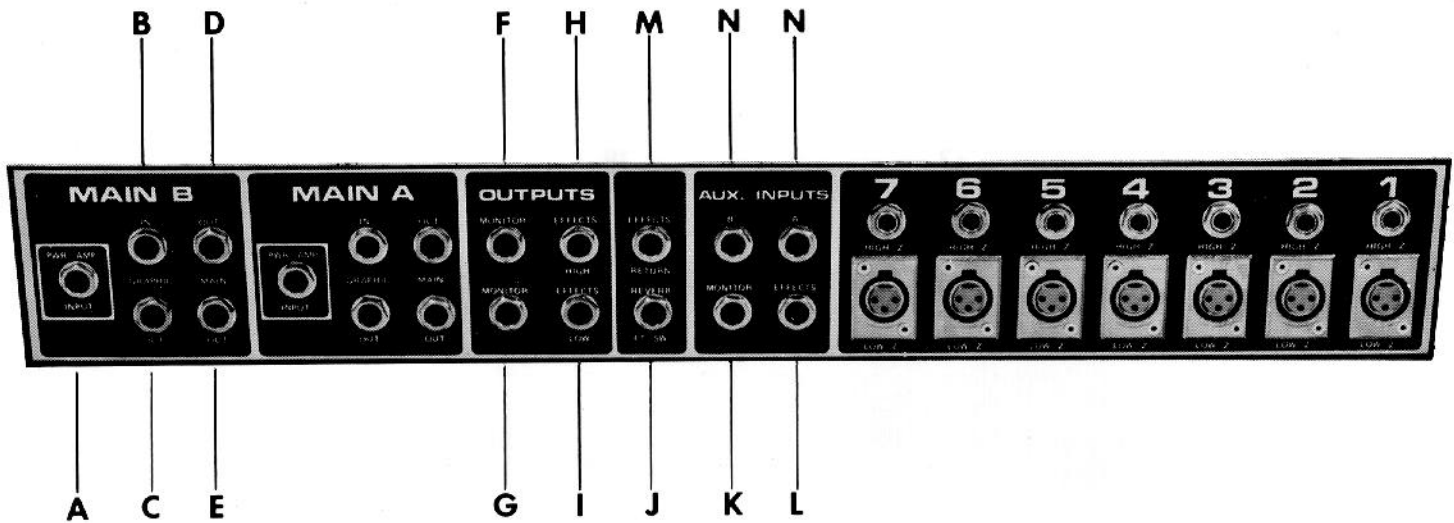

The **MAIN OUT (D) (E)** jacks are designed to allow the addition of power amplifiers as required by the user. The nominal output impedance is 600 Ohms with a typical level of 1.0 Volt r.m.s.

The two **MONITOR OUTPUT (F) (G)** jacks are unbalanced with a nominal output impedance of 600 Ohms and are capable of approximately 2.0 Volts r.m.s. output. These jacks are connected in parallel.

The **EFFECTS HIGH OUTPUT (H)** is capable of 2.0 Volts r.m.s. into 10.0 k Ohms and can be used to drive an additional power amplifier and speaker system from the effects buss to obtain an additional monitor send.

The **EFFECTS LOW OUTPUT (I)** is a lower level signal than the effects high and is intended to drive the input of an effects device such as an echo unit, phasor, etc. It is capable of 0.4 Volts r.m.s. into 10.0 k Ohms.

The **REVERB FOOTSWITCH JACK (J)** is used with an accessory footswitch to enable the operator to defeat the reverb function of the mixer from a remote position.

The **MONITOR AUXILIARY INPUT (K)** is an input to the monitor mixing busses to be used when patching another mixer to the PA 700S. These inputs can be used whenever an additional input is required to the monitor buss.

The **MAIN AUXILIARY INPUTS A and B (N)** are inputs to the main A and B mixing busses of the PA 700S. These inputs are used when patching another mixer to the PA 700S or any time a signal source is to be placed on the monitor mixing buss.

The **EFFECTS AUXILIARY INPUT (L)** is the input to the effects mixing buss of the PA 700S. This input mixes a signal with the effects buss at the same point as the individual channels and is to be used when patching two mixers together or anytime access is needed to the effects mixing buss.

The **EFFECTS RETURN JACK (M)** is where the signal returning from an effects device patches into the PA 700S.

The **POWER SWITCH** is the type that enables the operator to easily reverse the polarity of the line or mains cable. This is provided to minimize buzz by proper polarization of the AC power supply (mains) connection.

SPECIAL NOTE. Some export versions of the PA 700S do not have the two-way switch and the preceding information should be disregarded for these models.

A **HEAVY-DUTY POWER (MAINS) CABLE** is provided for durability under road conditions. This is a three wire approved cord, and it is **NOT** advisable to remove the ground pin under **ANY** circumstances. If you should find it necessary to operate the system where the proper three wire receptacles are not available, you should use a three-to-two wire adaptor.

17

18



15

16

13

22

14

23

8

9

10

The **REVERB CONTOUR** (16) is the control used to vary the tonality of the reverb signal and is a low cut type equalizer. This contour control is very useful in tailoring the reverb sound and in controlling reverb induced feedback. Balancing these reverb controls will yield many combinations of reverb delay, tonality, and sustain.

The **REVERB RETURN** (22) is the gain control element for the reverb system which normally consists of the internal delay line unless the switching jack for the reverb return has been plugged into. We have designed a system that provides an automatic patching facility for the internal reverb with the added flexibility of being able to accept signals from outside sources. This is accomplished by use of a switching jack on the rear panel (reverb return). If it should be necessary to use the reverb mixing buss for other purposes, we have designed in the flexibility to allow this option.

The **REVERB PAN** (23) is the control that enables the operator to place the signal from the effects level control on either, both, or any combination in between the left and right main channels. This panning capability **must** be present to retain **true stereo** stereo capability for the PA 700S. The action of this pan control is similar to those on the individual channels and should present no problem in operation.

The **MONITOR MASTER FADER** (10) is the output level control for the main monitor system. The same operating practices should be observed when using this control as when using the main channel controls. The individual channel monitor send controls should be set in such a manner that will allow the monitor master slider (fader) to be operated somewhere in the middle of its travel to allow yourself adequate control margins, up or down, as might be required on the job. The monitor output signal is flat, that is, we did not include equalization for the monitor in the PA 700S since this equalization is usually external to the mixer and is best performed on the stage itself, which is generally at some considerable distance from the mixer. It is because the mixer is usually located remotely from the performing area that it is sometimes difficult for the monitor equalization to be performed at the mixer.

The **METER SET CONTROLS** (17) (18) enables the **VU METERS** (19) (20) to be adjusted for proper indication of the relative output power of the internal power amplifiers of the PA 700S. When the PA 700S is received, the meters will be properly calibrated to indicate the clipping point of the power amplifiers. Occasional deflection into the red zone is normal, but continual pegging of the needles is to be avoided.

The **HEADPHONE LEVEL CONTROL** (21) adjusts the signal level at the headphone output jack. The headphone jack is a standard stereo type jack. Any impedance headphones may be used with the PA 700S.

REAR PANEL

The PA 700S rear panel features a complete patching panel for various input and output functions, as well as the microphone input connectors for each channel.

Each patch point is given an alphabetical diagram letter for identification purposes. The high impedance input connectors are standard phone jacks. The low impedance input connectors are of the cannon type, three conductor connectors to be used for low impedance microphones only, and will accept 150 to 600 ohm microphones.

<p>CAUTION NEVER USE THE LOW IMPEDANCE AND HIGH IMPEDANCE INPUTS SIMULTANEOUSLY!</p>

The PA 700S is a stereo mixer with self-contained power amplifiers, therefore, many of the input and output patch points perform the same functions. For this reason only one set of connectors will be explained in detail.

The **POWER AMP IN** (A) jack allows a signal to be connected directly to the internal power amplifier. When a plug is inserted in this jack, none of the front panel level controls will be functional. All mixer functions are disconnected when this jack is in use.

The **GRAPHIC IN** (B) jack enables a signal to be injected directly into the graphic equalizer and through to the power amplifier associated with that equalizer. All mixer functions are disabled when this jack is in use.

The **GRAPHIC OUT** (C) jack allows the user to have access to the channel output signal after the graphic equalizer and prior to the power amplifier. It is possible to mix an additional input at this point if the signal to be mixed is from a low impedance source and has a level of approximately 1.0 Volt r.m.s.

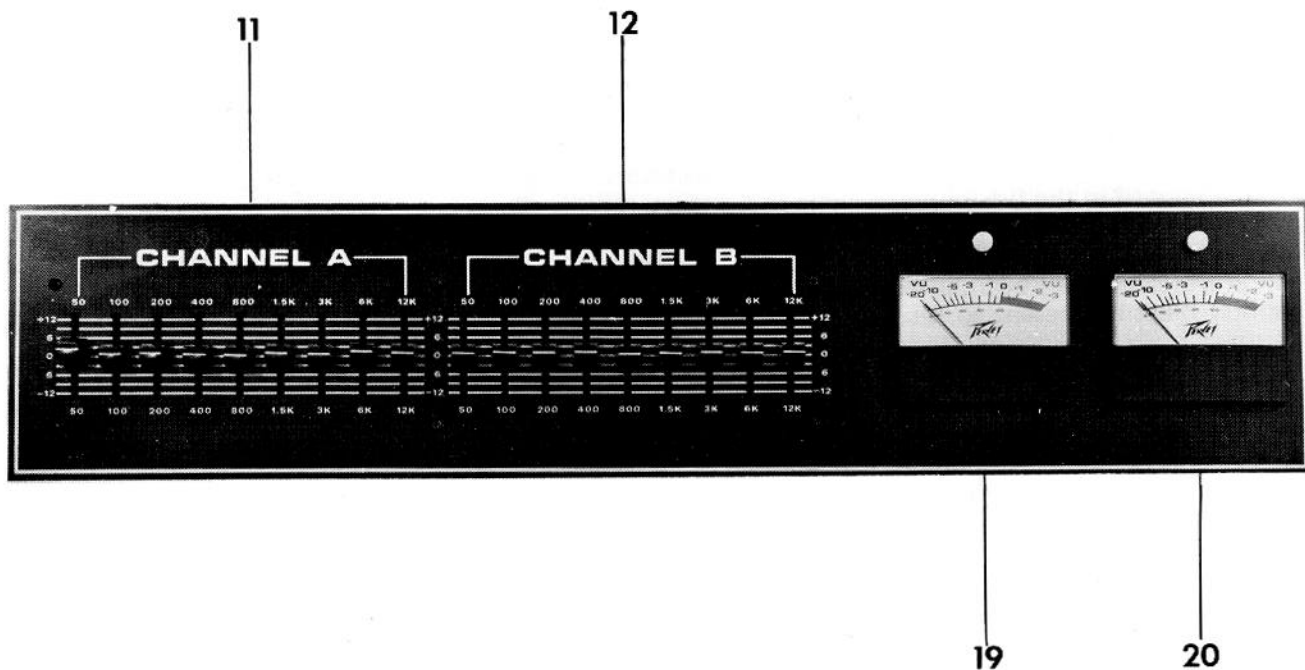

GRAPHIC EQUALIZERS (11) (12) are provided for each of the outputs from the master section. Each equalizer is capable of 12.0 dB of boost or cut at nine frequencies. The equalizers are of the latest active filter network design for maximum reliability and performance. When correctly used, graphic equalizers are a valuable tool for feedback suppression and compensating for speaker system deficiencies. They should not be considered as a cure-all for every acoustic environment.

When used for feedback suppression, the normal operating mode will be in the CUT configuration. It is very important that both equalizers be adjusted to the center or "flat" position before starting the feedback suppression procedure. The following procedure will aid in correctly adjusting the graphic equalizers.

1. Adjust the graphics to the center or "flat" position.
2. Adjust the individual channel EQ controls for the desired tonal quality.
3. Slowly start increasing the master level controls until feedback occurs. A point worth noting is that one or more microphones on stage will be more prone to feedback than others. This is rather easily determined: Just place your hand over the front of the microphone. Feedback should occur immediately if that microphone is at the threshold point. Keep this microphone in mind when performing the remainder of this procedure.
4. At this point, the system should be trying to go into a feedback mode. Move your hand in front of the worse case microphone if necessary to cause a sustained feedback condition. **DO NOT ALLOW** the system to go into a completely uncontrolled feedback condition.
5. Slowly adjust each band of the graphic equalizers until the first feedback frequency is found. Always adjust one slider at a time and if that slider does not reduce the feedback, return it to the center position. Once the frequency is found, adjust the equalizer slider to the point at which the feedback stops. Any further adjustment at that frequency will result in an undesirable overall sound.
6. There will usually be two or more points at which any sound system will go into feedback. Carefully "tune" out the second feedback point the same way as previously described. After the second feedback point is removed by equalization, little will be gained by further adjustment of the graphic equalizers. At all times, it should be remembered that the largest and most expensive systems will go into feedback at some point. Over equalization should be avoided at all costs; after a certain point, only overall degradation of your sound will result.

CONNECTIONS:

All input connections to the PA 700S should be made with shielded cable to reduce the possibility of hum and noise pickup. The low impedance microphone inputs are wired in accordance with professional industry standards. Pin 1 is shield, pin 2 is common, and pin 3 is hot. Extremely long cable runs may be made using the low impedance microphone inputs and low impedance microphones. When using the high impedance inputs, cable lengths in excess of 30 feet should be avoided if optimum fidelity is to be obtained.

The low level outputs (monitor, effects, etc.) from the PA 700S should be made using good quality shielded cable. Although these outputs are of relatively low impedance, cable lengths in excess of 50 feet should be avoided.

The high level or power outputs from the PA 700S must be made using number 16 or larger cable. Because of the low impedance and high currents involved, excessive power loss will be experienced if smaller wire is used. It is very important that all power output connections be securely made in the connector. If there is any question of connector and cable integrity, consult a competent service technician.

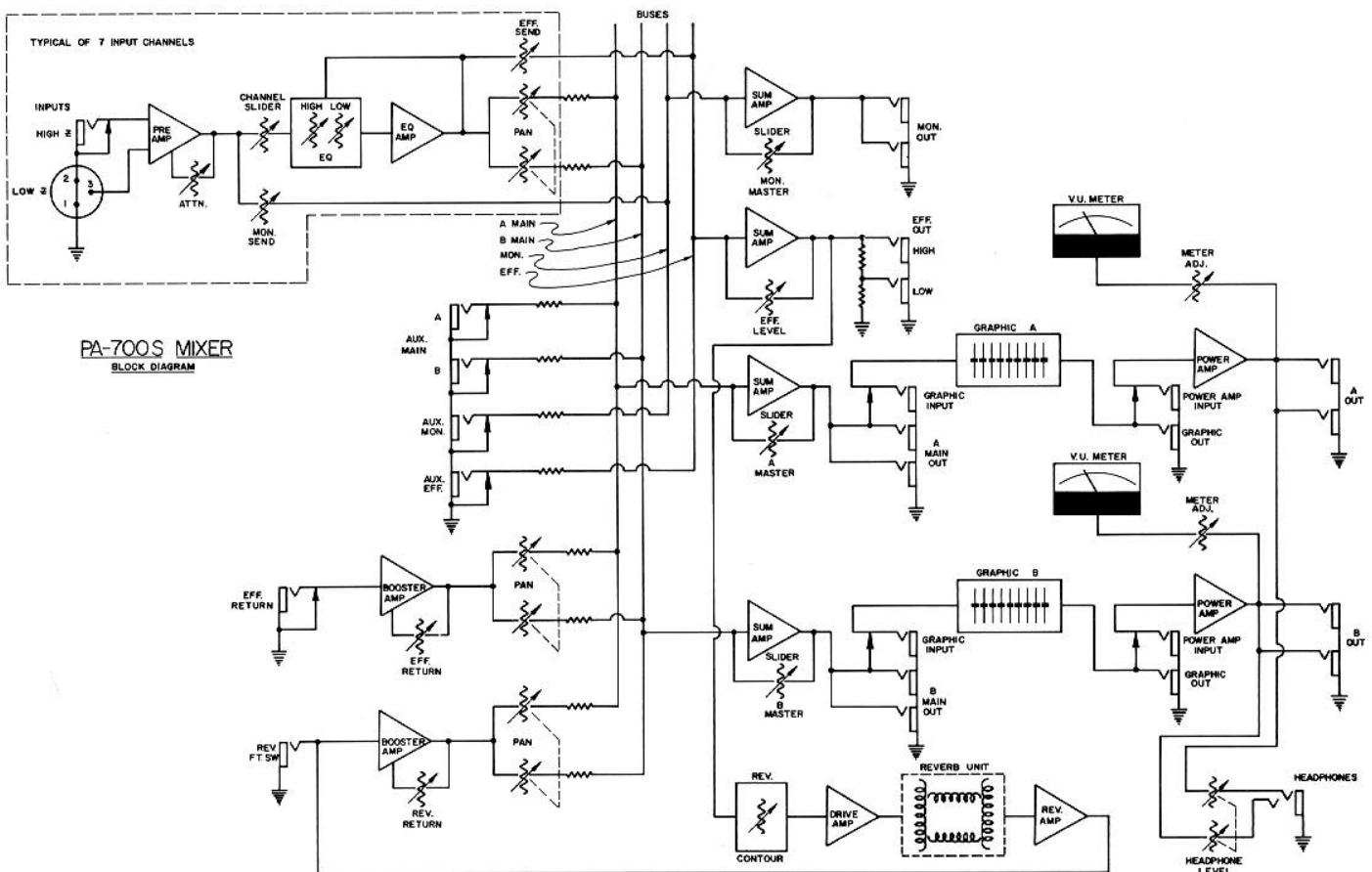

PA-700S MIXER
BLOCK DIAGRAM

PEAVEY ELECTRONICS CORP.

711 A Street / Meridian, Mississippi 39301



SPECS

Frequency Response:

20.0 Hz – 20.0 kHz \pm 2.0 dB @ 130 Watts r.m.s. Output

Total Harmonic Distortion:

0.15% THD 20 Hz – 20 kHz @ 130 Watts r.m.s. Output

Equivalent Input Noise:

Low Z input, -123 dBV @ 150 Ohms (0.7 μ V)

High Z input, -80 dB below 2.0 V r.m.s. @ 20.0 dB gain

Crosstalk:

-50.0 dB @ 1.0 kHz (between A and B outputs)

-70.0 dB @ 1.0 kHz (between monitor and effects outputs)

Inputs:

Low impedance unbalanced microphone 600 Ohm (cannon plug)

High impedance unbalanced line 50.0 k Ohm (¼ inch phone plug)

Input Attenuator:

Continuously variable gain from 0 dB to -40 dB

Used on both line and microphone inputs

Mixer Gain:

60.0 dB with graphic equalizers in flat position

Outputs:

A and B power outs – 130 Watts r.m.s. Z = 4.0 Ohms

A and B Main and Monitor:

Unbalanced 5.0 V r.m.s. into 10.0 k Ohms, 2.0 V r.m.s. into 600 Ohms (+8.0 dBm)

Effects High:

Unbalanced, 2.0 Volts r.m.s. into 10.0 K Ohms

Effects Low:

Unbalanced, 0.20 Volts r.m.s. into 10.0 K Ohms

Graphic Equalizer Outputs:

Unbalanced, 4.0 Volts r.m.s. into 600 Ohms

Inputs:

Power Amp input for maximum output: 1.20 Volts r.m.s.

Effects Return Level – Control Maximum

0.15 V r.m.s.

Aux Inputs:

Monitor – 2.50 V r.m.s.

Effects – 2.50 V r.m.s.

Graphic Equalizer:

All sliders adjusted to indicated flat response – 4.0 Volts r.m.s.

Effects Return: Control Maximum

0.50 Volts r.m.s.

Equalization – Channel:

Infinitely variable boost and cut, \pm 15.0 dB @ 100.0 Hz and 5.0 kHz each channel

Equalization – Graphic Equalizers:

Infinitely variable boost and cut, \pm 12.0 dB at 9 frequencies

Specifications and features printed in this manual are subject to change without notice



Peavey Electronics, Corp.
711 A Street
Meridian, Mississippi 39301