



WHITE-RODGERS

**50A55-286**

Integrated Furnace Control  
**INSTALLATION INSTRUCTIONS**

**Operator: Save these instructions for future use!**

**FAILURE TO READ AND FOLLOW ALL INSTRUCTIONS CAREFULLY BEFORE INSTALLING OR OPERATING THIS CONTROL COULD CAUSE PERSONAL INJURY AND/OR PROPERTY DAMAGE.**

**DESCRIPTION**

The 50A55-286 is an automatic gas interrupted ignition control that employs a microprocessor to continually monitor, analyze, and control the proper operation of the gas burner, inducer, and fan.

Signals interpreted during continual surveillance of the thermostat and flame sensing element initiate automatic ignition of the burner, sensing of the flame, and system shut-off during normal operation.

These controls incorporate system fault analysis for quick gas flow shut-off, coupled with automatic ignition retry upon sensing a fault correction.

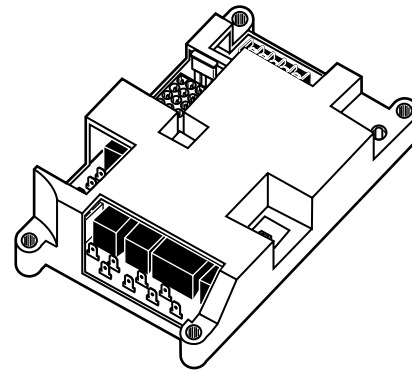

**PRECAUTIONS**

**⚠ GENERAL PRECAUTION**

Application of this type of control may cause flame rollout on initial start-up and could cause personal injury and/or property damage.

Replace only with exact model number, including dash number. Failure to use exact replacement control could cause personal injury and/or property damage.

If in doubt about whether your wiring is millivolt, line, or low voltage, have it inspected by a qualified heating and air conditioning contractor or licensed electrician.

Do not exceed the specification ratings.

All wiring must conform to local and national electrical codes and ordinances.

This control is a precision instrument, and should be handled carefully. Rough handling or distorting components could cause the control to malfunction.

**CONTENTS**

Description .....	1
Precautions .....	1
Specifications .....	2
Installation .....	3
Mounting & Wiring	
Operation .....	6

**⚠ CAUTION**

To prevent electrical shock and/or equipment damage, disconnect electric power to system at main fuse or circuit breaker box until installation is complete.

Label all wires prior to disconnection when servicing controls. Wiring errors can cause improper and dangerous operation.

This control is not intended for use in locations where it may come in contact with water. Suitable protection must be provided to shield the control from exposure to water (dripping, spraying, rain, etc.).

**⚠ WARNING**

Do not use on circuits exceeding specified voltage. Higher voltage will damage control and could cause shock or fire hazard.

Do not short out terminals on gas valve or primary control to test. Short or incorrect wiring will damage thermostat and could cause personal injury and/or property damage.



**WHITE-RODGERS DIVISION**  
EMERSON ELECTRIC CO.  
9797 REAVIS ROAD  
ST. LOUIS, MISSOURI 63123-5398

Printed in U.S.A.

**PART NO. 37-6101A**

9919

# SPECIFICATIONS

## ELECTRICAL RATINGS [@ 77°F (25°C)]:

**Input Voltage:** 25 VAC 50/60 Hz

**Max. Input Current @ 25 VAC:** 0.45 amp

Relay Load Ratings:

Valve Relay: 1.5 amp @ 25 VAC 50/60 Hz 0.6 pf

Ignitor Relay: 6.0 amp @ 120 VAC 50/60 Hz (resistive)

### Flame Current Requirements:

Minimum current to insure flame detection: 1 µa DC\*

Maximum current for non-detection: 0.1 µa DC\*

Maximum allowable leakage resistance: 100 M ohms

\*Measured with a DC microammeter in the flame probe lead

## OPERATING TEMPERATURE RANGE:

-40° to 175°F (-40° to 80°C)

## HUMIDITY RANGE:

5% to 93% relative humidity (non-condensing)

## MOUNTING:

Surface mount multipoise

## Timing Specs: (@ 60 Hz\*\*)

	<b>maximum</b>
Flame Establishing Time:	0.8 sec
Flame Failure Response Time:	2.0 sec

\*\* At 50 Hz, all timing specifications should be increased by 20%

**Gases Approved:** Natural, Manufactured, Mixed, Liquid Petroleum, and LP Gas Air Mixtures are all approved for use.

## TIMING SPECIFICATIONS

(All times are in seconds, unless noted otherwise)

	50A55-286
PRE-PURGE	0
INITIAL IGNITOR	17
RETRY IGNITOR	28
IGNITION ACTIVATION PERIOD	5
TRIAL FOR IGNITION PERIOD	7
RETRIES	2 times
VALVE SEQUENCE PERIOD	21
INTERPURGE	15
POST-PURGE	15
LOCKOUT TIME	200
DELAY TO HEAT ON	30
DELAY TO HEAT OFF*	60/90/ 120/180
DELAY TO COOL ON	0
DELAY TO COOL OFF	45
AUTO RESET	60 minutes
HUMIDIFIER	YES
ELECTRONIC AIR CLEANER	YES

\* This time will vary depending on option switch position. The control is factory-set at 60 sec. delay to heat off. See OPERATION section for further information.

**MOUNTING AND WIRING**

**⚠ WARNING**

Do not use on circuits exceeding specified voltage. Higher voltage will damage control and could cause shock or fire hazard.

**⚠ CAUTION**

To prevent electrical shock and/or equipment damage, disconnect electric power to system at main fuse or circuit breaker box until installation is complete. Failure to earth ground the appliance or reversing the neutral and hot wire connection to the line can cause shock hazard.

Shut off main gas to heating system until installation is complete.

Route and secure all wiring as far from flame as practical to prevent fire and/or equipment damage.

To prevent damage to the transformer, system components or wiring harness, take care when drilling new mounting holes. Failure to do so may result in electrical shock, fire hazard or equipment damage.

**NOTE**

All wiring should be installed according to local and national electrical codes and ordinances.

The control must be secured to an area that will experience a minimum of vibration and remain below the maximum ambient temperature rating of 175°F. The control is approved for minimum ambient temperatures of -40°F.

When mounting the control, any orientation is acceptable. Choose a location that will not damage, obstruct or place stress on the control's terminations, system wiring harness or system components. After finding a suitable location, drill four (4) 1/8" holes for mounting control. To ensure proper mounting hole locations, there is a **mounting hole template** on page 8 of this instruction sheet. Detach the page with the template from the instruction sheet and apply it to the mounting location. When drilling the holes, take care so that the transformer, wiring harness or other system components are not damaged. Four (4) #8 sheet metal screws are provided to complete the installation.

Refer to the wiring diagram and wiring table when connecting the 50A55 control to other components of the system.

UL approved, 105°C rated 18 gauge, stranded, 2/64" thick insulation wire is recommended for all low voltage safety circuit connections. Refer to 50A55 specification sheet for recommended terminals to mate with those on the control.

UL approved 105°C rated 16 gauge min., stranded, 4/64" thick insulation wire is recommended for all line voltage connections. Refer to 50A55 specification sheet for recommended terminals to mate with those on the control.

After installation or replacement, follow appliance manufacturer's recommended installation or service instructions to ensure proper operation.

The 50A55 has only one serviceable part—an automotive type fuse, which protects the low voltage transformer from damage if its output is short-circuited. If the fuse has opened up, remove whatever caused the short circuit and replace the fuse with only a 3 Amp automotive type fuse. If the fuse is not the cause of the control's problem, replace the entire 50A55 control. There are no other user serviceable parts.

# TYPICAL SYSTEM WIRING DIAGRAM

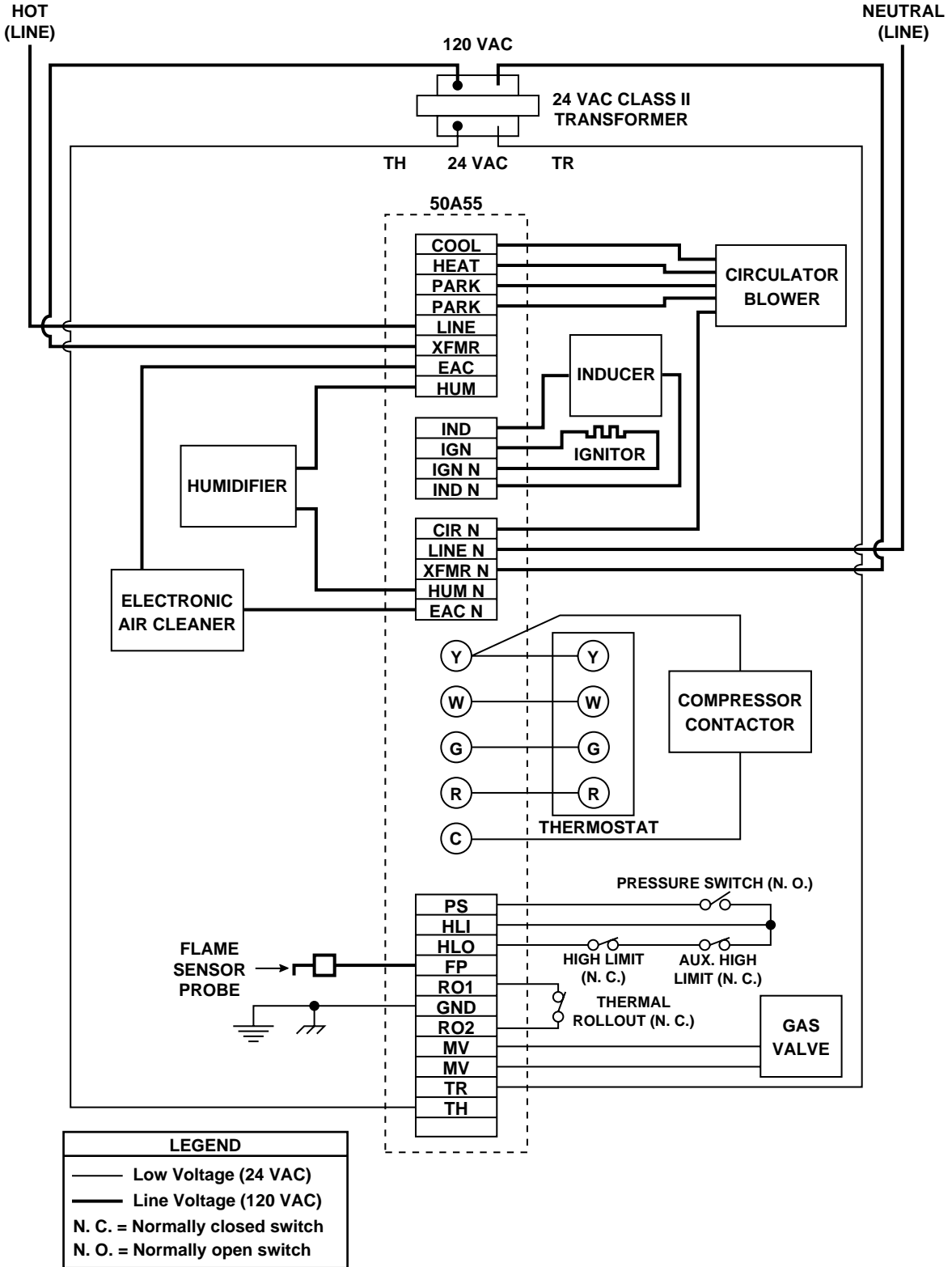

**TYPICAL SYSTEM WIRING TABLE**

<b>50A55 TERMINAL</b>	<b>TERMINAL TYPE</b>	<b>SYSTEM COMPONENT CONNECTION</b>
W G R Y  C	Terminal block with captive screws	low voltage thermostat W terminal (or equivalent) low voltage thermostat G terminal (or equivalent) low voltage thermostat R terminal (or equivalent) low voltage thermostat Y terminal (or equivalent) (2nd wire from Y terminal goes to 24 VAC HOT side of compressor contactor coil) 24 VAC COMMON side of compressor contactor coil
MV (2 terminals) TR TH RO1 RO2 FP PS HLI HLO GND (unused terminal)	12-pin connector & harness	gas valve (both gas solenoids are connected in parallel) 24 VAC transformer (low voltage COMMON side) 24 VAC transformer (low voltage HIGH side) rollout switch OUTPUT rollout switch INPUT flame sensor probe* pressure switch INPUT high limit INPUT high limit OUTPUT MUST BE RELIABLY GROUNDED TO CHASSIS
IND IGN IND N IGN N	4-pin connector & harness	inducer HOT side ignitor HOT side inducer NEUTRAL side ignitor NEUTRAL side
COOL	1/4" spade terminal	circulator blower COOL SPEED terminal
HEAT	1/4" spade terminal	circulator blower HEAT SPEED terminal
PARK (2 terminals)	1/4" spade terminal	unused circulator blower terminals
LINE	1/4" spade terminal	input voltage (120 VAC) HOT side
XFMR	1/4" spade terminal	24 VAC transformer line voltage HOT side
EAC (optional)	1/4" spade terminal	electronic air cleaner HOT side
HUM (optional)	1/4" spade terminal	humidifier HOT side
CIR N	1/4" spade terminal	circulator blower NEUTRAL terminal
LINE N	1/4" spade terminal	input voltage (120 VAC) NEUTRAL side
XFMR N	1/4" spade terminal	24 VAC transformer line voltage NEUTRAL side
EAC N (optional)	1/4" spade terminal	electronic air cleaner NEUTRAL side
HUM N (optional)	1/4" spade terminal	humidifier NEUTRAL side

\* maximum recommended flame probe wire length is 36 inches.

## OPERATION

### OPTION SWITCHES

The option switches on the 50A55-286 control are used to determine the length of the heat delay-to-fan-off periods. The following table shows the time periods that will result from the various switch positions.

HEAT delay-to-fan-off:	Set switch	
	#1	#2
60 sec.*	On	On
90 sec.	Off	On
120 sec.	On	Off
180 sec.	Off	Off

\*Factory set position

### HEAT MODE

In a typical system, a call for heat is initiated by closing the thermostat contacts. This starts the 50A55 control's heating sequence. The inducer blower and optional humidifier are energized and the ignitor is powered.

The ignitor is then allowed to warm up for 17 seconds. **The 120 VAC ignitors with a 17 second warm-up time manufactured by Carborundum, Ignitor Systems, Inc., or Norton must be used.** These ignitors are specially designed to heat up quickly at a low voltage condition without overheating at a high voltage condition.

At the end of the ignitor warm-up time, both valves in the 36E manifold gas valve are opened. Flame must be detected within 7 seconds.

If flame is detected, the delay-to-fan-on period begins. After the delay-to-fan-on period ends, the optional electronic air cleaner is powered and the circulator fan is energized at heat speed. When the thermostat is satisfied, the gas valve is de-energized. After proof of flame loss, the heat delay-to-fan-off period begins and the inducer blower remains energized to purge the system for 15 seconds. When the purge is complete, the inducer blower and humidifier are de-energized. After the delay-to-fan-off period ends, the circulator fan and electronic air cleaner are de-energized.

If flame is not detected, both valves are de-energized, the ignitor is turned off, and the 50A55 control goes into the "retry" sequence. The "retry" sequence provides a 15-second wait following an unsuccessful ignition attempt (flame not detected). After this wait, the ignition sequence is restarted with an additional 11 seconds of ignitor warm-up time. If this ignition attempt is unsuccessful, one more retry will be made before the control goes into system lockout.

If flame is detected, then lost, the 50A55 control will repeat the initial ignition sequence for a total of four "recycles". After four unsuccessful "recycle" attempts, the control will go into system lockout.

If flame is established for more than 10 seconds after ignition, the 50A55 controller will clear the ignition attempt (or retry) counter. If flame is lost after 10 seconds, it will restart the ignition sequence. This can occur a maximum of five times before system lockout.

During burner operation, a momentary loss of power of 50 milliseconds or longer will de-energize the main gas valve. When power is restored, the gas valve will remain de-energized and a restart of the ignition sequence will begin immediately.

A momentary loss of gas supply, flame blowout, or a shorted or open condition in the flame probe circuit will be sensed within 2.0 seconds. The gas valve will de-energize and the control will restart the ignition sequence. Recycles will begin and the burner will operate normally if the gas supply returns, or the fault condition is corrected, before the last ignition attempt. Otherwise, the control will go into system lockout.

If the control has gone into system lockout, it may be possible to reset the control by a momentary power interruption of one second or longer. Refer to **SYSTEM LOCKOUT FEATURES**.

### COOL MODE

In a typical system, a call for cool is initiated by closing the thermostat contacts. This energizes the 50A55 control. The compressor and optional electronic air cleaner are energized, and the circulator fan is energized at cool speed. After the thermostat is satisfied, the compressor is de-energized and the cool mode delay-to-fan-off period begins. After the cool delay-to-fan-off period ends, the circulator fan and electronic air cleaner are de-energized.

### MANUAL FAN ON MODE

If the thermostat fan switch is moved to the ON position, the circulator fan (cool speed) and optional electronic air cleaner are energized. When the fan switch is returned to the AUTO position, the circulator fan and electronic air cleaner (optional) are de-energized.

# SYSTEM LOCKOUT AND DIAGNOSTIC FEATURES

# DIAGNOSTIC FEATURES

## SYSTEM LOCKOUT FEATURES

When system lockout occurs, the gas valve is de-energized, the circulator blower is energized at heat speed, and, if flame is sensed, the inducer blower is energized. The diagnostic indicator light will flash or glow continuously to indicate system status. **(System lockout will never override the precautionary features.)**

**To reset the control after system lockout**, do one of the following:

1. Interrupt the call for heat or cool at the thermostat for at least one second, but less than 20 seconds (if flame is sensed with the gas valve de-energized, interrupting the call for heat at the thermostat will **not** reset the control).
2. Interrupt the 24 VAC power at the control for at least one second. You may also need to reset the flame rollout sensor switch.
3. After one hour in lockout, the control will automatically reset itself.

The 50A55 control continuously monitors its own operation and the operation of the system. If a failure occurs, the LED will indicate a failure code as shown below. **If the failure is internal to the control, the light will stay on continuously. In this case, the entire control should be replaced, as the control is not field-repairable.**

If the sensed failure is in the system (external to the control), the LED will flash in the following flash-pause sequences to indicate failure status (each flash will last approximately 0.25 seconds, and each pause will last approximately 2 seconds). If more than one failure is detected, the LED will alternate through all the failure codes that apply.

Continuous flashing (no pause)	Low flame sense signal
1 flash, then pause	Lockout caused by flame sensed when there should be no flame
2 flashes, then pause	Pressure switch stuck closed
3 flashes, then pause	Pressure switch stuck open
4 flashes, then pause	High limit open
5 flashes, then pause	Rollout switch open or rollout sensed
6 flashes, then pause	*Lockout caused by pressure switch opening 4 times in one cycle
7 flashes, then pause	*Lockout caused by no ignition (after 3 trials)
8 flashes, then pause	*Lockout caused by loss of flame 5 times in one heating cycle
9 flashes, then pause	115 Volt AC power reversed/ improper ground
12 flashes, then pause	Ignitor relay sense error

**The LED will also flash once at power-up.**

\* Will automatically restart from lockout after one hour. All other conditions need to be cleared for the control to resume normal operation.

# MOUNTING HOLE TEMPLATE

FOR MOUNTING HOLE LOCATIONS

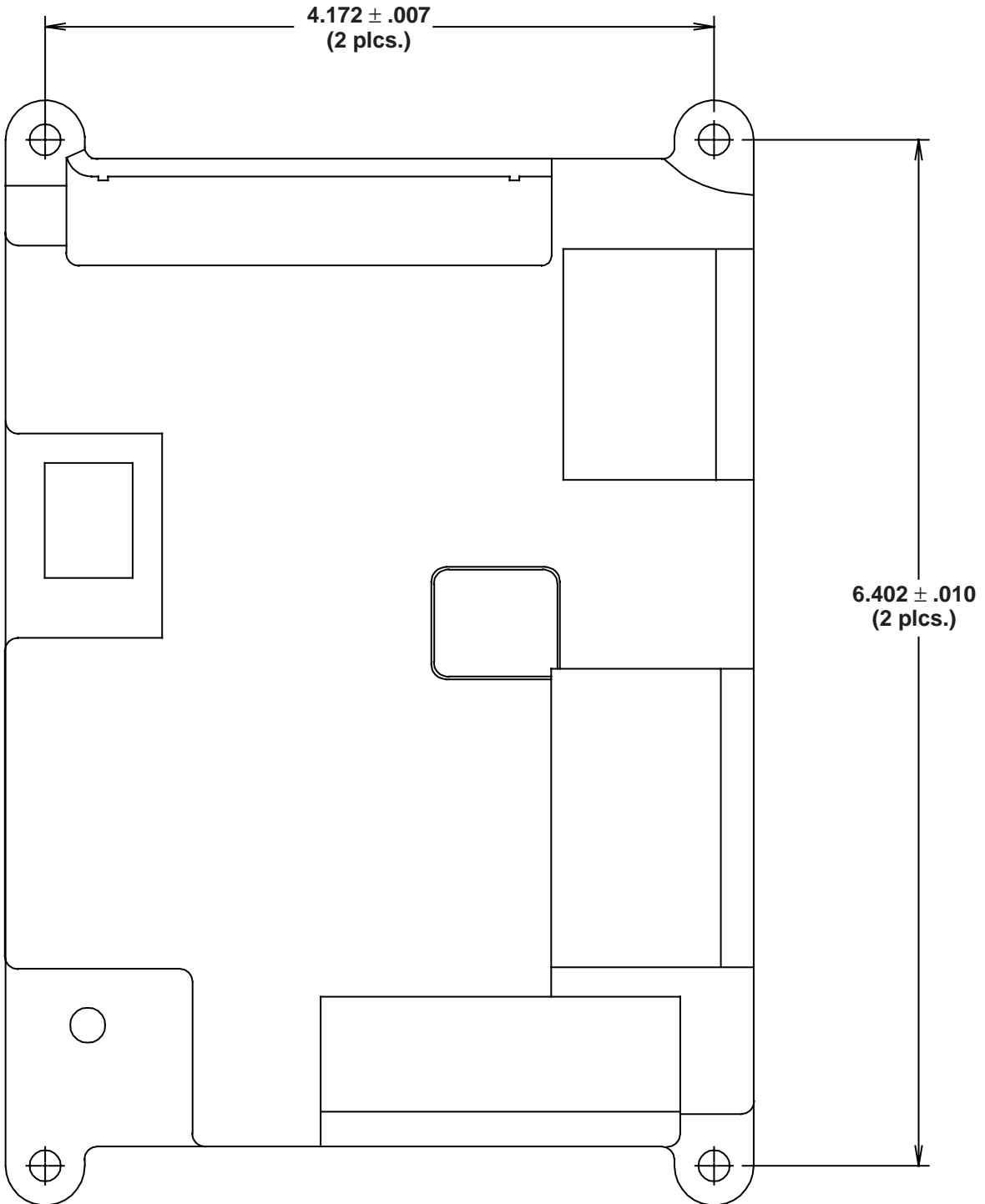

Refer to page 3 of the installation instructions for proper installation.