



**Model DP524
Two-Channel AC-2 / AC-3
Digital Audio Decoder**

Users' Manual

Users' Manual

For

Model DP524

**AC-2 / AC-3 Two-Channel
Digital Audio Decoder**

Dolby Laboratories Incorporated

U.S.A. 100 Potrero Avenue, San Francisco, CA 94103
Tel: 415-558-0200; Fax: 415-863-1373

U.K. Wootton Bassett, Wiltshire SN4 8QJ
Tel: 01793-842100; Fax: 01793-842101

DISCLAIMER OF WARRANTIES: Equipment manufactured by Dolby Laboratories is warranted against defects in materials and workmanship for a period of one year from the date of purchase. All warranties, conditions or other terms implied by statute are excluded to the fullest extent allowed by law.

LIMITATION OF LIABILITY: It is understood and agreed that Dolby Laboratories' liability whether in contract, in tort, under any warranty, in negligence or otherwise shall not exceed the cost of repair or replacement of the defective components and under no circumstances shall Dolby Laboratories be liable for incidental, special, direct, indirect or consequential damages (including but not limited to damage to software or recorded audio or visual material), or loss of use, revenue or profit even if Dolby Laboratories or its agents have been advised, orally or in writing, of the possibility of such damages.

This unit complies with the EMC requirements of prEN55103-1 and -2 when installed in accordance with this manual in an E2 environment

Dolby and the double-D symbol are registered trademarks of Dolby Laboratories Licensing Corporation.

TABLE OF CONTENTS

SECTION 1 Introduction

1.1 Introduction	1-1
1.3 Dolby AC-3 and AC-2.....	1-2
1.4 Data Rates, Sample Rates and Channels	1-3
1.5 Regulatory Notices	1-4

SECTION 2 Applications

SECTION 3 Pre-Installation

3.1 Unpacking.....	3-1
3.2 Inspection	3-1
3.2.1 Claims for Shipping Damage	3-1
3.3 Fusing Information	3-1
Main Fuse	3-1
Internal Fuse	3-2
3.4 Configuring Jumper Settings.....	3-2
3.4.1 Jumpers for Encoded Data In & Timing (J103)	3-4
Receive Timing / Receive Data Termination	3-4
Request to Send / Terminal Ready Enable	3-4
3.4.2 Signal Ground-to-Chassis Link	3-4
3.5 Configuring the Rear Panel DIP Switch S101.....	3-4
3.5.1 Switch nos. 1, 7 & 8 - Test Tone.....	3-5
3.5.2 Switch nos. 2, 5 & 6 Software Download	3-5
3.5.3 Switch no. 3 - Digital Output Format Selection	3-6
3.5.4 Switch nos. 4, 5 & 6 - Command/Aux Data.....	3-6

SECTION 4 Installation

4.1 Mounting	4-1
4.2 Audio Connections	4-1
4.2.1 S/PDIF Output - J102	4-1
4.2.2 AES/EBU Output - J101	4-1
4.2.3 Analog Outputs - J106/7.....	4-1
4.3 Data, Status, and Remote Control Connections	4-2
4.3.1 Encoded Data In & Timing - J103.....	4-2
4.3.2 RS-232 (J105).....	4-2
4.3.3 RS-422 (J106).....	4-3
4.3.4 Parallel Status and Control (J104).....	4-3

SECTION 5 Operation

5.1 Front Panel Status Indicators.....	5-1
5.2 Rear Panel Level Controls.....	5-2
5.3 Test Tone Level.....	5-2
5.4 Software Downloading Procedure.....	5-2

SECTION 6 Interface Specification and Description

6.1 DP524 Interface Specifications	6-1
AES/EBU Digital Audio Output, J101	6-1
S/PDIF Digital Audio Output, J102	6-1
Encoded Data In and Timing, J103, 37-pin D-connector:.....	6-1
Status / Control, J104, 25-pin D-connector:.....	6-2
RS-232 Port, J105	6-2
Analog Audio Input, J106 & J107	6-2
6.2 RS-449 Interface Description.....	6-3
6.2.1 Functional Description	6-3
6.2.2 Interface Timing	6-3
6.2.3 Back-to-Back Testing.....	6-4
6.3 Serial Control	6-5
6.3.1 System related commands	6-5
6.3.2 AC-3 Related commands	6-7

SECTION 7 Product Specifications

1.1 Introduction

The Dolby Model DP524 is a digital audio decoder unit supporting both Dolby AC-2 and Dolby AC-3 digital audio coding algorithms. The unit supports up to two channels of audio. The data rates available are considerably lower than that required to convey conventional PCM data (between 40k and 384k bits/sec) yet provide exceedingly high audio quality.

The unit automatically configures itself for the appropriate data rate, sample rate and algorithm type.

Both digital (AES/EBU and S/PDIF) and analog outputs are provided.

A full duplex serial control system has also been implemented which allows the user to retrieve Status or Aux. data from the decoder. It is also possible for the user to update the units software revision by means of a serial download capability.

The decoder provides front panel system status indicators as well as the ability to respond to serial inquiries relating to system status.

A digitally generated test signal is provided for system alignment and troubleshooting and can be activated from a rear panel switch or via the serial control system.

Rear panel analog output level trimmers are provided.

This manual includes installation procedures, descriptions of Model DP524 operation, and interface specifications.

1.2 Features

- Automatic algorithm, data rate and sample rate selection
- Dolby AC-3 audio coding algorithm from 40 kbps - 384 kbps
- Mono, Dual-Mono or Stereo modes for AC-3
- Dolby AC-2 audio coding algorithm from 128 kbps - 384 kbps
- Mono 2-channel modes for AC-2
- Analog outputs with 20-bit D/A converters
- Digital outputs (AES/EBU and S/PDIF)
- Software download capability for software upgrades
- Selectable auxiliary data rates (0 - 9600 baud).
- RS-232 and RS-422 serial interfaces allows Control, Status, Software Download and Auxiliary data.
- Built-in test tone generator

1.3 **Dolby AC-3 and AC-2**

Despite the low, spectrum-efficient data rate, Dolby AC-3 and AC-2 yield very high audio quality and is suitable for the most demanding of professional and consumer distribution applications. First demonstrated to the film industry in May of 1991, Dolby AC-3 audio coding technology has evolved into a very sophisticated and flexible system for the digital representation of high quality sound. Dual channel implementations of the AC-3 algorithm can be user-configured to operate in Dual Mono or Stereo modes.

AC-3 and AC-2 are compatible with Dolby Matrix Surround decoding. A wide range of bit rates and audio coding modes are supported with this audio coding technique, and are summarized in the tables on the following page.

1.4 Data Rates, Sample Rates and Channels

Possible AC-3 Data Rates, Sample Rates and Number of Channels

Data Rate	Sample rate	Channels
40 kbps	32kHz, 44.1kHz or 48kHz	Set by Encoder
48 kbps	32kHz, 44.1kHz or 48kHz	Set by Encoder
56 kbps	32kHz, 44.1kHz or 48kHz	Set by Encoder
64 kbps	32kHz, 44.1kHz or 48kHz	Set by Encoder
80 kbps	32kHz, 44.1kHz or 48kHz	Set by Encoder
96 kbps	32kHz, 44.1kHz or 48kHz	Set by Encoder
112 kbps	32kHz, 44.1kHz or 48kHz	Set by Encoder
128 kbps	32kHz, 44.1kHz or 48kHz	Set by Encoder
160 kbps	32kHz, 44.1kHz or 48kHz	Set by Encoder
192 kbps	32kHz, 44.1kHz or 48kHz	Set by Encoder
224 kbps	32kHz, 44.1kHz or 48kHz	Set by Encoder
256 kbps	32kHz, 44.1kHz or 48kHz	Set by Encoder
320 kbps	32kHz, 44.1kHz or 48kHz	Set by Encoder
384 kbps	32kHz, 44.1kHz or 48kHz	Set by Encoder

Possible AC-2 Data Rates, Sample Rates and Number of Channels

Data Rate	Sample rate	Channels
128 kbps	48kHz	1
192 kbps	48kHz	1
256 kbps	48kHz	2
384 kbps	48kHz	2

1.5 Regulatory Notices

FCC

This equipment has been tested and found to comply with the limits for a Class A digital device, pursuant to part 15 of the FCC Rules. These limits are designed to provide reasonable protection against harmful interference when the equipment is operated in a commercial environment. This equipment generates, uses, and can radiate radio frequency energy and, if not installed and used in accordance with this instruction manual, may cause harmful interference to radio communications. Operation of this equipment in a residential area is likely to cause harmful interference in which case the user will be required to correct the interference at his or her own expense.

UL

Troubleshooting must be performed by trained technicians. Do not attempt to service this equipment unless you are qualified to do so.

WARNING: Check that the correct fuses have been installed. To reduce the risk of fire, replace the fuses only with the same type and rating.

Exposed portions of the power supply are electrically "hot". In order to reduce the risk of electrical shock, the power cord **MUST** be disconnected when the cover of this equipment is removed.

UK

Connections for the United Kingdom:

WARNING: THIS APPARATUS MUST BE EARTHED

As the colours of the cores in the mains lead may not correspond with the coloured markings identifying the terminals in your plug, proceed as follows:

- The core which is coloured green and yellow must be connected to the terminal in the plug which is marked with the letter **E** or by the earth symbol  or coloured green or green and yellow.
- The core which is coloured blue must be connected to the terminal which is marked with the letter **N** or coloured black.
- The core which is coloured brown must be connected to the terminal which is marked with the letter **L** or coloured red.

IEC NOTICES

IMPORTANT SAFETY NOTICE

This unit complies with the safety standard IEC65. To ensure safe operation and to guard against potential shock hazard or risk of fire, the following **must** be observed:

- o Ensure the **voltage selector** is set to the correct mains voltage for your **supply**.
- o Ensure **fuses** fitted are the **correct rating and type** as marked on the unit.
- o The unit **must be earthed** by connecting to a correctly wired and **earthed** power outlet.
- o The **power cord** supplied with this unit must be wired as follows:

Live—Brown Neutral—Blue Earth—Green/Yellow

(GB)

IMPORTANT – NOTE DE SECURITE

Ce materiel est conforme à la norme IEC65. Pour vous assurer d'un fonctionnement sans danger et de prévenir tout choc électrique ou tout risque d'incendie, veuillez à observer les recommandations suivantes.

- o Le selecteur de tension doit être placé sur la valeur correspondante à votre alimentation réseau.
- o Les fusibles doivent correspondre à la valeur indiquée sur le materiel.
- o Le materiel doit être correctement relié à la terre.
- o Le cordon secteur livré avec le materiel doit être câblé de la manière suivante:

Phase—Brun Neutre—Bleu Terre—Vert/Jaune

(F)

WICHTIGER SICHERHEITSHINWEIS

Dieses Gerät entspricht der Sicherheitsnorm IEC65. Für das sichere Funktionieren des Gerätes und zur Unfallverhütung (elektrischer Schlag, Feuer) sind die folgenden Regeln unbedingt einzuhalten:

- o Der Spannungswähler muß auf Ihre Netzspannung eingestellt sein.
- o Die Sicherungen müssen in Type und Stromwert mit den Angaben auf dem Gerät übereinstimmen.
- o Die Erdung des Gerätes muß über eine geerdete Steckdose gewährleistet sein.
- o Das mitgelieferte Netzkabel muß wie folgt verdrahtet werden:

Phase—braun Nulleiter—blau Erde—grün/gelb

(D)

NORME DI SICUREZZA – IMPORTANTE

Questa apparecchiatura è stata costruita in accordo alle norme di sicurezza IEC 65. Per una perfetta sicurezza ed al fine di evitare eventuali rischi di scossa elettrica o d'incendio vanno osservate le seguenti misure di sicurezza:

- o Assicurarsi che il selettore di cambio tensione sia posizionato sul valore corretto.
- o Assicurarsi che la portata ed il tipo di fusibili siano quelli prescritti dalla casa costruttrice.
- o L'apparecchiatura deve avere un collegamento di messa a terra ben eseguito; anche la connessione rete deve avere un collegamento a terra.
- o Il cavo di alimentazione a corredo dell'apparecchiatura deve essere collegato come segue:

Filo tensione—Marrone Neutro—Blu Massa—Verde/Giallo

(I)

AVISO IMPORTANTE DE SEGURIDAD

Esta unidad cumple con la norma de seguridad IEC65. Para asegurarse un funcionamiento seguro y prevenir cualquier posible peligro de descarga o riesgo de incendio, se han de observar las siguientes precauciones:

- o Asegúrese que el selector de tensión esté ajustado a la tensión correcta para su alimentación.
- o Asegúrese que los fusibles colocados son del tipo y valor correctos, tal como se marca en la unidad.
- o La unidad debe ser puesta a tierra, conectándola a un conector de red correctamente cableado y puesto a tierra.
- o El cable de red suministrado con esta unidad, debe ser cableado como sigue:

Vivo—Marrón Neutro—Azul Tierra—Verde/Amarillo

(E)

VIKTIGA SÄKERHETSÅTGÄRDER!

Denna enhet uppfyller säkerhetsstandard IEC65. För att garantera säkerheten och gardera mot eventuell elchock eller brandrisk, måste följande observeras:

- o Kontrollera att spänningsväljaren är inställd på korrekt nätspänning.
- o Kontrollera att säkringarna är av rätt typ och för rätt strömstyrka så som anvisningarna på enheten föreskriver.
- o Enheten måste vara jordad genom anslutning till ett korrekt kopplat och jordat el-uttag.
- o El-sladden som medföljer denna enhet måste kopplas enligt följande:

Fas—Brun Neutral—Blå Jord—Grön/Gul

(S)

BELANGRIJK VEILIGHEIDS-VOORSCHRIFT:

Deze unit voldoet aan de IEC65 veiligheids-standaards. Voor een veilig gebruik en om het gevaar van elektrische schokken en het risico van brand te vermijden, dienen de volgende regels in acht te worden genomen:

- o Controleer of de spanningscarroussel op het juiste Voltage staat.
- o Gebruik alleen zekeringen van de aangegeven typen en waarden.
- o Aansluiting van de unit alleen aan een geaarde wandcontactdoos.
- o De netkabel die met de unit wordt geleverd, moet als volgt worden aangesloten:

Fase—Bruin Nul—Blauw Aarde—Groen/Geel

(NL)

The Dolby Model DP524 is suitable for a variety of point-to-point and point-to-multipoint digital transmission applications, including cable, telecommunications and satellite or terrestrial microwave links. The very high audio quality and low, spectrum-efficient data rates of the AC-2 and AC-3 coding process make them particularly appropriate for these applications.

2.1 Cable

Whether for audio-only services or for an enhanced digital audio service accompanying video, the DP524 is ideally suited to cable applications. The availability of low data rates permits efficient use of cable bandwidth as either a baseband signal or as a subcarrier above video.

2.2 Telecommunications

The Model DP524 can be used with T1 or ISDN lines for point-to-point communications. Film and recording studios, as well as mastering facilities, can be interconnected with audio and control data to enable multi-site, real-time operations. Broadcast applications include STL, ICR, and backhaul operations. Because only a small portion of the T1 bit stream is used, the residual capacity remains available for additional audio channels or other services (e.g., voice or computer data), or fractional service can be ordered. In ISDN applications, the number of "B" channels needed is determined by the chosen bit rate.

3.1 Unpacking

Before proceeding further, be sure to inspect the outer carton for shipping damage. If there has been any penetration to the carton, be sure to inspect the unit for any physical damage in those areas.

Several accessories have been provided in the packet provided with this manual. Please compare them with the following list to ensure that there are no missing items:

Rack screws and washers

Power cord

Spare fuse 1A (Part No. 56016)

Spare fuse, 2A, used on the internal power supply (Part No. 56017)

Warranty card (Part No. 91292)

Communications Products Group Registration card (Part No. 91228)

3.2 Inspection

Carefully remove the unit from its carton. Remove the plastic wrapping and place on a flat surface.

If there are no signs of physical damage, proceed to "Fusing Information" below.

3.2.1 Claims for Shipping Damage

If, in your inspection procedure, you should find physical damage, please notify the carrier immediately. All claims for damage must be filed by the recipient. Dolby Laboratories or your dealer/distributor will be happy to assist where possible.

3.3 Fusing Information

WARNING To reduce the risk of fire, replace fuses only with the same type and rating.

The DP524 utilizes a universal switching power supply that can accommodate the full range of nominal voltages between 90 Vac and 264 Vac and any frequency between 50 Hz and 60 Hz.

Main Fuse

Use 1 Amp, 250V, 20 mm, Time-Lag fuse.

With a small flat-blade screwdriver, open the fuse compartment door in the AC power input housing (see figure).

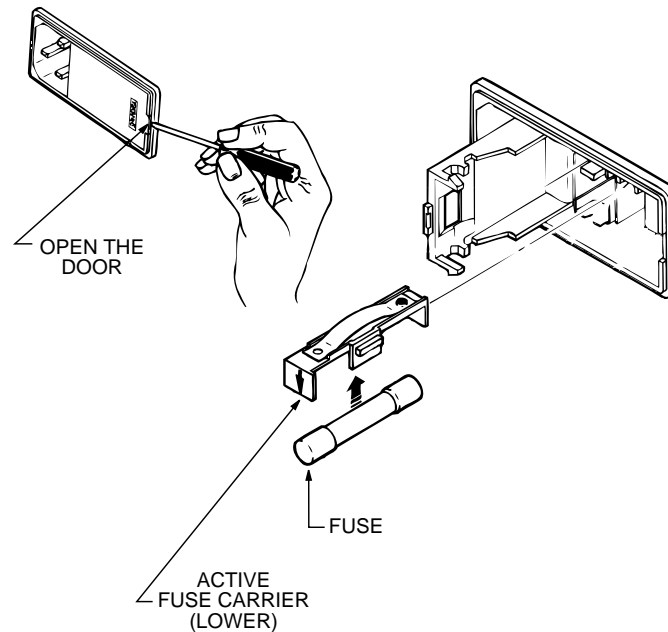

Check that the fuse in the active (lower) fuse carrier is of the correct rating. A spare fuse can be stored in the upper fuse carrier position.

Snap the fuse compartment door closed.

Internal Fuse

The switching power supply contains a separate fuse. Most fault conditions should be protected by the main fuse. The internal fuse rating is:

2 Amp, 250V, 20 mm, fast-blow.

3.4 Configuring Jumper Settings

The Model DP524 includes certain user-selectable options that are configured by means of internal jumpers, as shown below. Their default settings (shipped with the unit) are shown in the figure. Any jumpers not specifically mentioned are for factory use only and should not be disturbed.

If you need to gain access to the interior of the DP524 to change these jumpers, proceed as follows:

WARNING Be sure that the unit is NOT powered up. The power cord must not be connected.

Using a #2 Phillips head screwdriver, remove the 12 screws securing the top cover/front panel subassembly to the chassis; there are three screws on the

front, rear, and each of the sides of the unit. The three black screws should be reserved for affixing at the front.

Note The front panel is attached to the top cover by means of 4 screws also affixing the handles. These do *not* need to be removed.

By grasping the front panel handles, gently pull the top cover/front panel assembly forward then away towards the rear. Carefully set aside this sub-assembly.

Reverse the above procedure when re-assembling the unit.

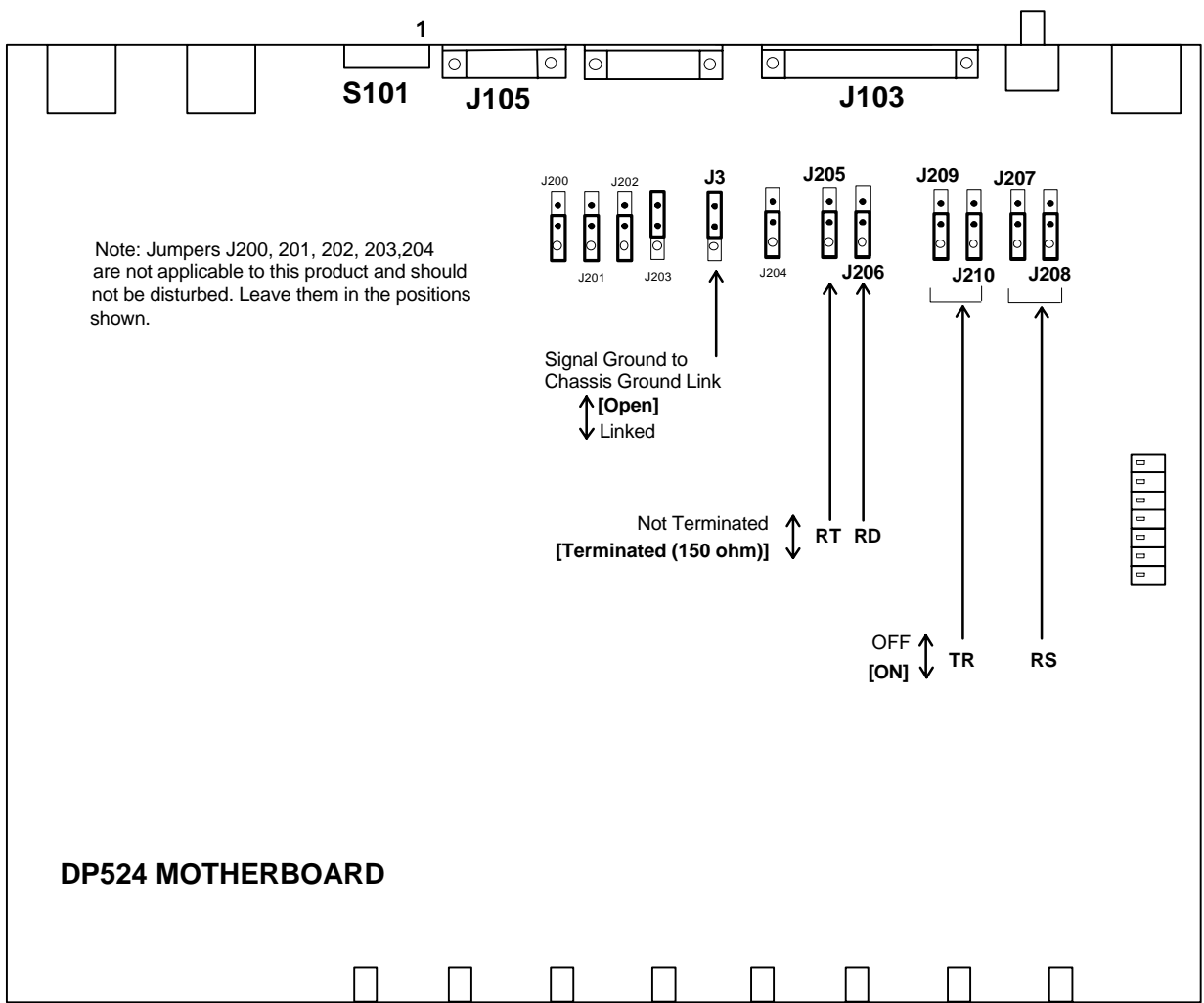

3.4.1 Jumpers for Encoded Data In & Timing (J103)

Receive Timing J205 / Receive Data J206 [terminated]

Termination resistors (150 ohms) are provided across the "RT" and "RD" inputs. These inputs are terminated in the default configuration, which should be appropriate for most applications. Certain situations may require that these inputs be unterminated (e.g., multiple inputs driven from a single output).

Request to Send J207 & J208 / Terminal Ready J209 & J210 [on]

Handshake signals "RS" and "TR" can be turned on or off, depending on the application. The default settings for these signals is "on."

3.4.2 Signal Ground-to-Chassis Link J3 [open]

It is normal practice to connect signal ground to power line ground for many reasons, including safety. In most systems, minimum induced hum is obtained when this connection is made at one and only one piece of equipment in the audio chain. To minimize the addition of circulating ground currents in a particular installation, the default setting is for this jumper link to be open. Note that there is always a 1k ohm resistor across the link so that the audio ground is never totally isolated from the chassis ground. To connect audio ground directly to chassis ground in the DP524, move jumper J3 to the closed position (move jumper towards the front of the unit).

CAUTION The chassis is always connected to the ground pin of the power line cord. For safety reasons this ground wire **MUST NEVER** be disconnected.

3.5 Configuring the Rear Panel DIP Switch S101

The Model DP524 includes certain user-selectable options that are configured by means of a rear panel DIP switch, S101. Some of them should be configured prior to first use. Others can be changed as operational needs dictate (See also Section 5, Operation).

The default settings (delivered from the factory) are shown in *brackets* in the table below. Before installing the unit, be sure to verify that the switch positions are in their desired positions. Explanations follow below.

S101 Switch No.	Function	Up (On)	Down (Off)
1	Test Tone	Tone on	[Normal]
2	Download/Normal	Download	[Normal]
3	AES/EBU / S/PDIF	[AES/EBU]	S/PDIF
4	Command/Aux data mode	Command mode	[Aux Data mode]
5	Baud rate select 1	See below	[See below]
6	Baud rate select 2	See below	[See below]
7	Test Tone sample rate 1	See below	[See below]
8	Test Tone sample rate 2	See below	[See below]

Note Switch positions 5 and 6 take on two roles:

- They set the **Aux Data** output baud rate when S101-2 is in the **Normal** position and S101-4 is in the **Aux Data** position
 - They set the **Download** baud rate when S101-2 is in the **Download** position.
 - Their positions are immaterial when S101-2 is in the **Normal** position and S101-4 is in the **Command** position; the **Command** baud rate is at a fixed 9600 baud.
-

3.5.1 Switch nos. 1, 7 & 8 - Test Tone [down]

Switch position S101-1 activates the built-in test tone generator at a nominal -18dB amplitude relative to both digital and analog full scale. The decoded signal is interrupted when the test tone is activated. Switch positions S101-7 and S101-8 are typically chosen to correspond to the incoming sample rate, so that both the test tone and audio output have the same sample rate. The frequency of the test tone varies somewhat with the sample rate chosen.

Output Sample Rate	Frequency	S101-7	S101-8
48 kHz	1125 Hz	[Down]	[Down]
44.1 kHz	1033 Hz	Down	Up
32 kHz	750 Hz	Up	Down
Illegal	Undefined	Up	Up

Keep S101-1 in the **Normal** position when not using this feature.

3.5.2 Switch nos. 2, 5 & 6 Software Download [down]

The RS-232 port (J105) can be used for upgrading of the audio coding algorithm software.

When invoking the download mode, the baud rate selection switches S101-5 and S101-6 must also be set, depending on the data transfer rate, per the following table:

Baud Rate	S101-5	S101-6
9,600	[Down]	[Down]
19,200	Down	Up
38,400	Up	Down

See Section 5.4 for download instructions. RS-232 interface specifications are located in Section 6.1.

Keep S101-2 in the **Normal** position when not using this feature.

3.5.3 Switch no. 3 - Digital Output Format Selection [up]

Position this switch to corresponds to the type of digital output signal format. Refer to Section 4 for information regarding audio connections.

Format	S101-3
S/PDIF	Down
AES/EBU	[Up]

The switch setting selects how the digital bit stream is marked. S/PDIF is synonymous with "consumer" format, AES/EBU is synonymous with "professional" format.

Note Digital audio output is fed to both the BNC and the XLR connectors of the rear of the unit simultaneously. However, only one of the connectors may be used at a time; otherwise the unit will be excessively loaded, and may malfunction.

3.5.4 Switch nos. 4, 5 & 6 - Command/Aux Data [down]

Switch position determines whether the RS-232 port J105 is configured as an Aux Data output or is used for remote control.

Mode	S101-4
Aux Data	[Down]
Command	Up

In Aux Data mode, the unit will send out serial data contained in the digital audio data stream at the baud rate defined by the table below.

In Command Mode, the unit responds to a series of five byte packets at a fixed rate of 9600 baud. See Section 6.3 for further details.

Switch 5 & 6 sets the baud rate for the AC-3 Aux Data channel as follows:

Baud Rate (AC-3)	S101-5	S101-6
0	[Down]	[Down]
1200	Down	Up
2400	Up	Down
9600	Up	Up

Notes No handshaking is used in Aux Data mode.

AC-2 Mono supports an aux data rate of 600 Baud *only*; AC-2 Stereo supports 1200 Baud *only*. The position of these switches is therefore immaterial.

4.1 Mounting

The DP524 is designed for 19 inch rack mounting, but may be mounted in any plane and with any orientation. It occupies 1U (1 3/4") of space.

When mounting the unit, ensure that there is air flow around it, and that it is not mounted directly above any equipment generating high amounts of heat. The unit will operate within specifications up to a maximum ambient temperature of 50° C (122° F). Note that the ambient temperature inside a poorly-ventilated rack may be considerably higher than that in the room.

4.2 Audio Connections

4.2.1 S/PDIF Output - J102

Connect this output to the **S/PDIF** digital audio input of the equipment following the DP524 using 75 ohm shielded cable.

Note To maintain better mechanical and electrical integrity, the rear panel connector on the DP524 is a BNC female connector rather than the typical phono jack normally encountered in S/PDIF installations.

4.2.2 AES/EBU Output - J101

Alternatively, connect this output to the **AES/EBU** digital audio input of the equipment following the DP524 using 110 ohm balanced and shielded cable.

Note The AES/EBU and S/PDIF outputs cannot be used simultaneously. If connections are made to both outputs, neither will function properly.

4.2.3 Analog Outputs - J106/7

Alternatively, if using the **Analog** outputs, make connections at the DP524 analog outputs J106 (Ch. A) and/or J107 (Ch. B) which are provided with industry-standard XLR female connectors.

Note When operating in single channel audio coding modes, only audio from Channel A is used.

AES and IEC convention calls for XLR pin 2 to be “high/hot” and pin 3 to be “low/cold”. In the interests of maintaining international standardization, we suggest that the AES and IEC recommendations be followed.

For optimum immunity to radio-frequency interference, cable shields must be connected to the shells of the XLR connectors, not to pin 1.

In an installation where the source is unbalanced, avoid ground loops by using two conductor shielded cable exactly as for balanced circuits; in other words, ensure that the unbalancing (connecting the wire to pin 3 to ground) occurs only at the end remote from the Model DP524. Note that both audio pins of the XLRs (pins 2 and 3) must be connected; neither may be left open.

4.3 Data, Status, and Remote Control Connections

Note Serial Command control can also be implemented in specialized applications by means of the RS-232 port, J105). See Section 6.3.

4.3.1 Encoded Data In & Timing - J103

Make the Encoded Data In and Timing connections to the 37-pin D-connector J103. This connector follows the interface specifications of EIA standard RS-449 in the type DT mode (data and timing signals only). Under RS-449, the DP524 is categorized as data terminal equipment (DTE), and is typically connected to data circuit-terminating equipment (DCE) such as telecommunications or RF modems. Detailed information on the RS-449 interface is provided in Section 6.2.

System Clock Requirements

A phase-locked loop (PLL) generates all sample and data timing. The PLL locks to an external data clock at the coder data rate, and a crystal-based oscillator is used within the PLL to minimize timing jitter in the sampled audio data. The frequency locking range of the loop is ± 100 ppm. As an example, a 192kHz data rate would require a stable external data clock in the range from 191.9808 kHz to 192.0192 kHz, with a 50% duty cycle per RS-449.

4.3.2 RS-232 (J105)

The RS-232 connection can be used for three purposes:

- a. As an input for downloading software upgrades; see Section 5.4.
- b. As an I/O port for remote commands. See Section 8.
- c. As an output for auxiliary data sent from the encoder and embedded in the digital audio data stream. RS-232 interface data can be found in Section 7.1. The Command/Aux data switch (S101-4) should be in the Down position. The communications protocol for command mode is fixed at 1 stop bit, no parity and the baud rate is set as follows:

Baud Rate	S101-5	S101-6
0	Down	Down
1200	Down	Up
2400	Up	Down
9600	Up	Up

Where is baud rate of the Encoder (generating the Aux data stream) is higher than the baud rate of the Decoder it is possible that data may be lost.

4.3.3 RS-422 (J106)

The RS-422 connection is not supported in this product.

4.3.4 Parallel Status and Control (J104)

It is possible to remotely enable the Test Tone and Download functions:

By taking pin 19 of the J104 to +5V, the Test Tone is enabled.

By taking pin 20 of the J104 to +5V, Download is enabled.

The front panel indicators **Fault**, **Test** and **Mute** are reflected on pins 21, 22 and 23 respectively of J104. A low level (<0.5V) represents the inactive condition. A high level (>4.5V) represents an active condition.

Pins 14-18 and 25 are digital ground points.

Once the DP524 is installed and operational, no user-intervention is required. In normal operation, one of the Green LEDs will indicate the incoming sample rate (32kHz , 44.1 kHz or 48 kHz); the signal presence indicators will also illuminate if appropriate.

5.1 Front Panel Status Indicators

Fault

The **Fault** LED indicates power supply or processor/memory failure. Upon power-up of the DP524, the internal processor performs a diagnostic check of all memory locations and verifies that processor clock signals are active. Failure of any of these tests is indicated by the illumination of this LED. Memory or processor failure during operation will result in a similar display.

Test

The yellow **Test** LED indicates that the Test Tone Generator has been activated (position 1 of rear panel DIP Switch S101 is up).

Mute

The red **Mute** LED indicates that the unit is not currently able to recover valid audio. This may be because the incoming data rate is outside the lock range of the internal phase lock loop or because no valid data is being fed into the unit.

48k

The green **48k** LED indicates that the unit is currently locked to the incoming data stream and is recovering valid audio at 48 kHz sample rate.

44.1k

The green **44.1k** LED indicates that the unit is currently locked to the incoming data stream and is recovering valid audio at 44.1 kHz sample rate.

32k

The green **32k** LED indicates that the unit is currently locked to the incoming data stream and is recovering valid audio at 32 kHz sample rate.

Signal Presence A & B

These two green LEDs indicate that audio is present on the analog outputs at a level greater than approximately -60dB Full Scale.

5.2 Rear Panel Level Controls

Each analog output connector has a level control adjacent to it. Each analog output is adjustable (at full scale) over a range of below 0dBu to greater than +24dBu.

5.3 Test Tone Level

The operating level for the test tone generator of the Model DP524 is -18dB relative to full scale. This is useful when calibrating the analog outputs and also for checking proper operation of the digital outputs.

The actual frequency of the tone is dependent upon sample rate (see section 3.5.1).

5.4 Software Downloading Procedure

In the event that a software upgrade is required, the RS-232 (J105) may be used to download the appropriate files and reprogram the EEPROM residing in the DP524. When this method of upgrade is desired, the necessary files will be supplied in IBM PC compatible format. The downloading procedure is described below.

Remove all connectors to the DP524 except for the mains power.

Connect rear panel connector **J105** to a standard PC serial port.

Note the position of **S101-5** and **S101-6**. They must be restored to this position when the software downloading is complete.

Set the baud rate select switches **S101-5** and **S101-6** as desired, according to the table below:

Baud Rate	S101-5	S101-6
9600	Down	Down
19200	Down	Up
38400	Up	Down

Set rear panel switch **S101-2** to the **up** position. As soon as this is done the Front panel LEDs **Mute**, **48k**, **44.1k** and **32k** will all be illuminated. During the download sequence the **Test** LED will flash.

Software upgrades are supplied by Dolby Laboratories and include complete instructions relating to the download procedure.

After the unit has been upgraded, move switch **S101-2** back to its down position. The unit will then reboot and begin running the new code.

Return switches **S101-5** and **S101-6** to their original positions.

SECTION 6
INTERFACE SPECIFICATION AND DESCRIPTION

6.1 DP524 Interface Specifications

AES/EBU Digital Audio Output, J101

XLR-type connector, 5V p-p typical, 110 Ohms.

Pin	Connection
1	Digital signal ground
2	Digital Audio +
3	Digital Audio -

S/PDIF Digital Audio Output, J102

BNC-type connector, 0.5V p-p typical, 75 ohms.

Encoded Data In and Timing, J103, 37-pin D-connector:

Pin	Connection	Pin	Connection
1	Shield (chassis ground)		
2	NC (no connection)	20	NC
3	NC	21	NC
4	NC	22	NC
5	NC	23	NC
6	RD + (receive data +)	24	RD – (receive data –)
7	NC	25	NC
8	RT + (receive timing +)	26	RT – (receive timing –)
9	NC	27	NC
10	NC	28	NC
11	NC	29	NC
12	NC	30	NC
13	NC	31	NC
14	NC	32	NC
15	NC	33	NC
16	NC	34	NC
17	NC	35	NC
18	NC	36	NC
19	SG (signal ground)	37	NC

Status / Control, J104, 25-pin D-connector:

Pin	Connection	Comments
1	NC	Do Not Connect
2	NC	Do Not Connect
3	NC	Do Not Connect
4	NC	Do Not Connect
5	NC	Do Not Connect
6	NC	Do Not Connect
7	NC	Do Not Connect
8	NC	Do Not Connect
9	NC	Do Not Connect
10	NC	Do Not Connect
11	NC	Do Not Connect
12	NC	Do Not Connect
13	VREF	Logic Level Reference (+5V)
14	DGND	Digital ground
15	DGND	Digital ground
16	DGND	Digital ground
17	DGND	Digital ground
18	DGND	Digital ground
19	TEST IN	Input, Enable Test Tone
20	DOWNLOAD	Input, Enable Software Download
21	FAULT	Output, System Failure
22	TEST OUT	Output, Test Mode
23	MUTE	Output, Decoder Muted
24	NC	Do Not Connect (start -)
25	DGND	Digital ground

RS-232 Port, J105

Pin	Connection	Comments
1	DCD	direct connection to DTR, DSR, and CTS
2	RX	asynchronous data out
3	TX	asynchronous data in
4	DTR	direct connection to DCD, DSR, and CTS
5	Ground	
6	DSR	direct connection to DCD, DTR, and CTS
7	NC	
8	CTS	direct connection to DCD, DTR, and DSR
9	NC	

Analog Audio Input, J106 & J107

XLR-type connectors

Pin	Connection
1	Analog signal ground
2	Analog Audio +
3	Analog Audio -

6.2 RS-449 Interface Description

6.2.1 Functional Description

The Dolby Model DP524 provide a standard RS-449 interface in the type DT mode (data and timing signals only, no handshakes) through 37-pin male D-connectors. RS-449 is the mechanical specification for a balanced (differential) transmission system meeting RS-422 and RS-423 electrical specifications. The Model DP524 is configured as data terminal equipment (DTE), and are typically connected to data circuit-terminating equipment (DCE) such as RF modems. The DP524 decoder receives a data clock from a DCE device on the receive timing (RT) pins, and receives data on the receive data (RD) pins. The internal timing and sample clocks of the DP524 are phase-locked to ST and RT, respectively. In addition to these differential signals, the connector also provides pins for signal and chassis ground; connector pinout is given in the section above. No other RS-449 signals are supported in these units.

6.2.2 Interface Timing

A “mark,” or “off” state is said to exist when the “+” side of a signal is at a lower potential than the corresponding “-” side. A “space,” or “on” state exists when the opposite condition is true. The following timing diagram shows the relationship between clock and signal lines:

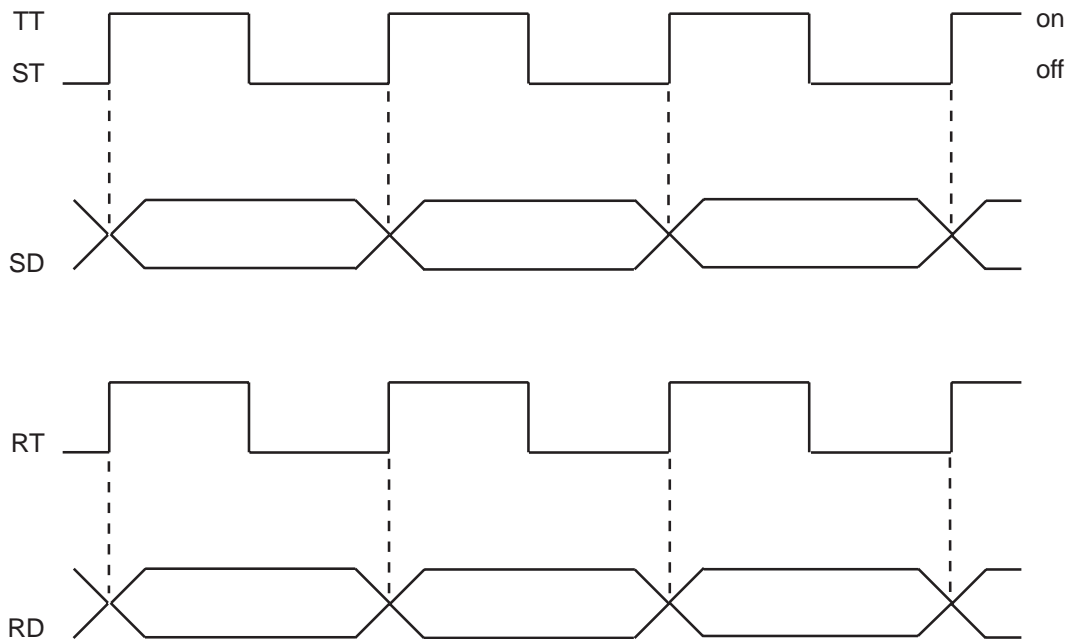

6.2.3 Back-to-Back Testing

For purposes of testing the Model DP523 and Model DP524 in a back-to-back configuration, a special cable must be constructed. Note that a DTE-to-DTE connection is not supported by the RS-449 specification. A standard 37-wire cable cannot be used to interconnect the units. The special cable connects the TT outputs of the DP523 directly to the ST inputs of the DP523 and to the RT inputs of the DP524. This cable also connects the SD outputs of the DP523 to the RD inputs of the DP524, and connects the signal grounds (SG) of the two units. The DP523 end of the cable should be labeled “Encoder” and the DP524 end should be labeled “Decoder”. The cable connections are shown below:

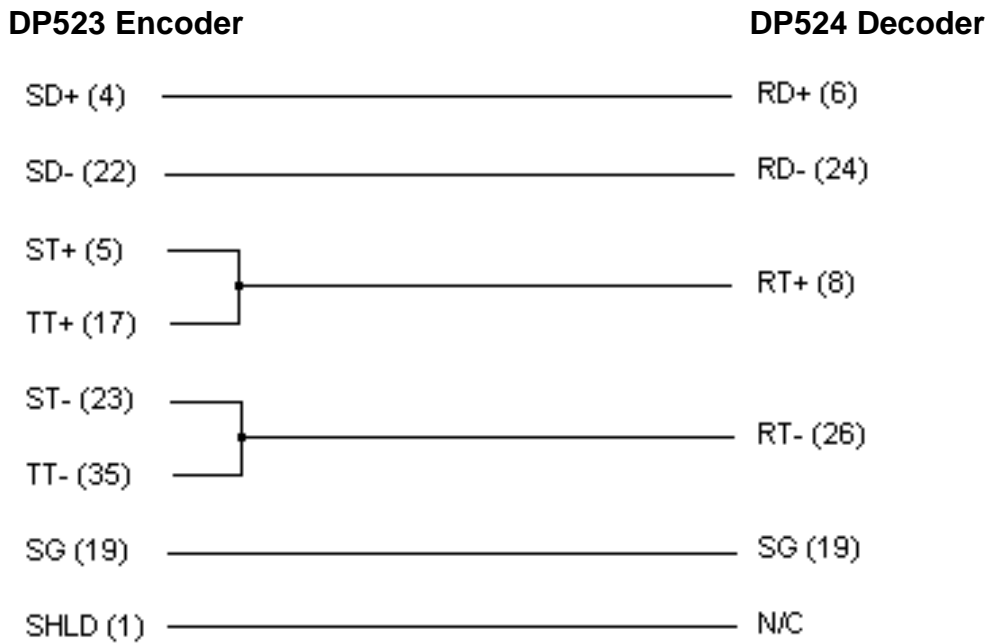

6.3 Serial Control

It is possible to command the DP524 via the RS-232 port, J105 on the rear of the unit when the Command/Aux data switch (S101-4) is in the Up position. The communications protocol for command mode is fixed at 9600 baud, 1 stop bit, no parity.

Note This port cannot be used simultaneously for external control and Auxiliary Data output.

The unit expects to receive a five byte sequence and responds in one of the following ways:

- If the command sequence is not expecting to return a value (as in the case of Enable Test Tone) then successful receipt of the command is responded with a single ASCII character '*'.
- If the command sequence is not received correctly (for example the stop byte \$FD is corrupted) then the unit responds with a single ASCII character '?'.
- If the command is expecting a reply (as in the case of Return Status) then that status byte is returned.

The data sequence is as follows (\$ prefix denotes hexadecimal notation):

6.3.1 System related commands

The following commands are system commands and will be responded to regardless of the algorithm currently loaded.

Command \$14: Enable/Disable Test Tone

\$FB	\$20	\$14	data	\$FD
------	------	------	------	------

Where data is as follows:

B7	B6	B5	B4	B3	B2	B1	B0
Enable	0	0	0	SR2	SR1	0	0

Enable, SR2 and SR1 are defined as follows:

SR1	SR2	Enable	Comment
X	X	0	Test Tone Disabled
0	0	1	48kHz Sample Rate, 1125Hz Tone
1	0	1	44.1Khz Sample Rate, 1033Hz Tone
0	1	1	32kHz Sample Rate, 750Hz Tone
1	1	1	Illegal

Note:

This command will only be accepted if the DIP switch controlling the Test Tone (S101-1) is set for normal operation. If S101-1 is set active, this command will respond with a '?' instead of '*'.

Command \$18: Return System Status

\$FB	\$20	\$18	0	\$FD
------	------	------	---	------

The unit returns the following byte:

B7	B6	B5	B4	B3	B2	B1	B0
0	Dr_lock	Sr_lock	Test	48kHz	44.1kHz	32kHz	Mute

Each bit is returned set if the associated signal is active. Dr_lock and Sr_lock are internal signals. Dr_lock is active when the decoder has successfully locked to the incoming RS-449 clock 'RT' : Receive Timing.

Command \$19: Return System Contents

\$FB	\$20	\$19	Index	\$FD
------	------	------	-------	------

This command returns a collection of strings of characters which describe the contents of the current firmware revision including the revision of the system control software and all of the loaded algorithms.

The 'Index' byte starts at 0 and is incremented until the unit returns a zero. On each successive call, the unit will return the following ASCII character in the associated null terminated string. A Linefeed character (decimal 10) separates each string.

Command \$1A: Return Current Algorithm

\$FB	\$20	\$1A	Index	\$FD
------	------	------	-------	------

The 'Index' byte starts at 0 and is incremented until the unit returns a zero. On each successive call, the unit will return the following ASCII character in the associated null terminated string.

This command returns the name of the current decoder algorithm which is loaded.

Command \$1B: Return Current bitrate.

\$FB	\$20	\$1B	0	\$FD
------	------	------	---	------

This command returns a byte which describes the current decoder bit-rate. NOTE: This data is only valid if the Dr_lock bit in 'Return System Status' byte is true.

This command will return \$FF if the decoder is in Test Tone mode or if the decoder is in normal mode but does not have an input data clock that it can lock to.

Otherwise the returned data is as follows:

B7	B6	B5	B4	B3	B2	B1	B0
0	0	0	0	BR3	BR2	BR1	BR0
BR3	BR2	BR1	BR0	Bit Rate (total)			
0	0	0	1	40k bits/sec			
0	0	1	0	48k bits/sec			
0	0	1	1	56k bits/sec			
0	1	0	0	64k bits/sec			
0	1	0	1	80k bits/sec			
0	1	1	0	96k bits/sec			
0	1	1	1	112k bits/sec			
1	0	0	0	128k bits/sec			
1	0	0	1	160k bits/sec			
1	0	1	0	192k bits/sec			
1	0	1	1	224k bits/sec			
1	1	0	0	256k bits/sec			
1	1	0	1	320k bits/sec			
1	1	1	0	384k bits/sec			
1	1	1	1	448k bits/sec			

6.3.2 AC-3 Related commands

The following commands are only applicable to the AC-3 algorithm. If they are issued when any other algorithm has been loaded, they will be ignored.

Command \$40: High Level Dynamic Range control

\$FB	\$20	\$40	data	\$FD
------	------	------	------	------

Where data is a byte of value 0..\$ff.

0 corresponds to a fractional control value of 0.0.

\$ff corresponds to a fractional control value of 0.996.

Command \$41: Low Level Dynamic Range control

\$FB	\$20	\$41	data	\$FD
------	------	------	------	------

Where data is a byte of value 0..\$ff.

0 corresponds to a fractional control value of 0.0.

\$ff corresponds to a fractional control value of 0.996.

Command \$42: Set Compression mode

\$FB	\$20	\$42	data	\$FD
------	------	------	------	------

Where data is as follows:

B7	B6	B5	B4	B3	B2	B1	B0
0	0	0	0	0	0	C1	C0

C0 and C1 are defined as follows:

C1	C0	Comment
0	0	Custom mode, no digital dialog normalization
0	1	Custom mode, digital dialog normalization
1	0	Line Out Mode
1	1	RF mode

Specifications¹

Italics = nomenclature for panel markings, switch labels, jumpers, LEDs, etc.
All inputs and outputs are TTL compatible unless otherwise stated.

Frequency Response

Lower limit: 20 Hz. Upper limit varies from 8 to 20 kHz depending on algorithm. Tolerance \pm 0.3 dB.

Distortion²

AC-2 Less than 0.1 % at 1 kHz.
Less than 0.2 %, 20 Hz - algorithm upper limit.

AC-3 Less than 0.005 %, 20 Hz - algorithm upper limit.

Dynamic Range

Greater than 108 dB (encode/decode, digital I/O).
Greater than 100 dB (encode/decode, analog I/O).

Crosstalk

Less than - 120 dB @ 1 kHz

Level Stability

AC-2 Better than 0.2 dB.
AC-3 Better than 0.01 dB.

Audio Coding Method

Dolby AC-2 or AC-3³

Time Delay

Varies with algorithm. Contact Dolby Laboratories.

External Timing

External clock range: \pm 100 ppm of total data rate; RS-422 input (balanced voltage digital interface, 50% D.C. per RS-449 specification).

Audio Sample Rate

32 kHz, 44.1 kHz or 48 kHz (AC-3).
48kHz (AC-2).

Test Tone Generator

Digital equivalent of approximately 1 kHz sine wave at. Actual frequency dependent on output sample rate. Level is -18dB Full Scale.

Analog Audio Output

3-pin XLR-type male. Active balanced output, 22 ohms, adjustable up to +24dbu Full Scale.

¹Subject to change without notice.

²Measured with an Audio Precision System One.

³Patents Pending Worldwide.

Digital Audio Outputs

AES/EBU, 3-pin XLR-type, male, balanced, 110 ohms $\pm 5\%$, 5Vpp nominal.
S/PDIF, BNC female connector, unbalanced, 75 ohms $\pm 5\%$, 0.5Vpp nominal.

Data Output / Command Input

RS232, Male 9-pin D connector. RS-422, Female 25-pin D connector. These connectors may be used to load software upgrades into the unit, allow serial control of the unit or to output auxiliary data. Mode and Baud Rate of the serial ports are set by the rear panel switch.

S101-1 Enable Internal Test Tone Generator

S101-2 Normal/Download Control

S101-3 S/PDIF / AES/EBU select

S101-4 Select Command/Data mode

S101-5 Baud Rate Select 1

S101-6 Baud Rate Select 2

S101-7 Tone sample rate 1

S101-8 Tone sample rate 2

Rear Panel Controls

Output Level trim, 10-turn, each channel is adjustable from -10 to +24dBm Full Scale.

Front Panel Indicators*Signal Presence, CH A*

Green indicates that a signal greater than -60dB FS is present on the channel A output.

Signal Presence, CH B

Green indicates that a signal greater than -60dB FS is present on the channel B output.

32kHz

Green indicates that unit is locked to the incoming bitrate and that the sample rate of the incoming data is 32kHz.

44.1kHz

Green indicates that unit is locked to the incoming bitrate and that the sample rate of the incoming data is 44.1kHz.

48kHz

Green indicates that unit is locked to the incoming bitrate and that the sample rate of the incoming data is 48kHz.

Mute

Red LED indicates that there is no incoming clock or the bit stream does not contain valid audio.

Test

Yellow warns that the Test Tone Generator is selected.

Fault

Red indicates a power supply or processor/memory failure.

Remote Control Inputs

Enable Test Tone

Software Download

Status Outputs

Fault output

Test output

Mute output

General

Power Requirements

90-260 VAC, 50-60 Hz, 24VA

Dimensions and Weight

1- $\frac{3}{4}$ x 19 x 11- $\frac{3}{4}$ inches (4.45 x 48.26 x 29.8 cm), 8.5 pounds (3.9 kg), approx.

Emissions

Complies with the limits for a Class A digital device, pursuant to Part 15 of the FCC Rules.

Environmental Requirements

Temperature Operating : 0 °C to 50 °C, natural convection cooling.
 Non-operating (Storage): -40 °C to 85 °C.

Warranty

1-year limited, parts and labor.

