



# Operator's Manual

THE POWER WITHIN™



Model 430447  
433447  
580447  
583447  
589447

Vanguard  
Gasoline

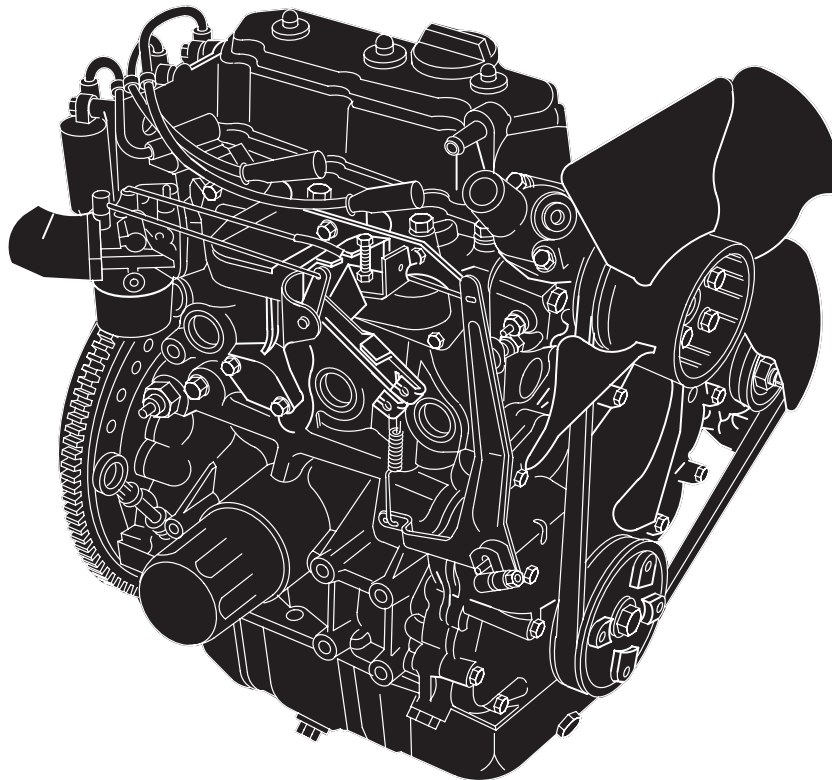

## TABLE OF CONTENTS

Safety .....	2	Starting and Stopping .....	8-9
Engine Information .....	4-5	Maintenance .....	10-14
Oil .....	6	Adjustments .....	14-15
Fuel and Coolant .....	7	Service & Storage .....	16
Gauges .....	7-8	Warranty Information .....	17

For replacement parts or technical assistance, record below the engine model, type, and code numbers along with the date of purchase. These numbers are located on your engine (see the "Engine Information" page).

**Date of purchase:** \_\_\_\_\_  
MM/DD/YYYY

**Engine model:** \_\_\_\_\_  
Model: Type: Code:



### BEFORE OPERATING ENGINE

- Read entire Operating & Maintenance Instructions AND the instructions for the equipment this engine powers.\*
- Failure to follow instructions could result in serious injury or death.

### THE OPERATING & MAINTENANCE INSTRUCTIONS CONTAIN SAFETY INFORMATION TO

- Make you aware of hazards associated with engines
- Inform you of the risk of injury associated with those hazards, and
- Tell you how to avoid or reduce the risk of injury.

\* Briggs & Stratton does not necessarily know what equipment this engine will power. For that reason, you should carefully read and understand the operating instructions for the equipment on which your engine is placed.

The safety alert symbol () is used to identify safety information about hazards that can result in personal injury.



A signal word (DANGER, WARNING, or CAUTION) is used with the alert symbol to indicate the likelihood and the potential severity of injury. In addition, a hazard symbol may be used to represent the type of hazard.

 **DANGER** indicates a hazard which, if not avoided, will result in death or serious injury.

 **WARNING** indicates a hazard which, if not avoided, could result in death or serious injury.







 **CAUTION** indicates a hazard which, if not avoided, might result in minor or moderate injury.

**CAUTION**, when used **without** the alert symbol, indicates a situation that **could result in damage to the engine**.









 **WARNING** 

The engine exhaust from this product contains chemicals known to the State of California to cause cancer, birth defects, or other reproductive harm.

### HAZARD SYMBOLS AND MEANINGS

 Fire	 Explosion	 Moving Parts	 Hot Liquid or Steam
 Toxic Fumes	 Hot Surface	 Shock	

### THE INTERNATIONAL SYMBOLS USED ON THE ENGINE OR IN THIS MANUAL INCLUDE:

 Safety Alert	 On Off	 Oil	 Stop
 Read Operator's Manual	 Fuel Shutoff	 Choke	 Fuel

# SAFETY



## WARNING

Gasoline and its vapors are extremely flammable and explosive.



Fire or explosion can cause severe burns or death.

### WHEN ADDING FUEL

- Turn engine OFF and let engine cool at least 2 minutes before removing gas cap.
- Fill fuel tank outdoors or in well-ventilated area.
- Do not overfill fuel tank. Fill tank to approximately 1-1/2 inches below top of neck to allow for fuel expansion.
- Keep gasoline away from sparks, open flames, pilot lights, heat, and other ignition sources.
- Check fuel lines, tank, cap, and fittings frequently for cracks or leaks. Replace if necessary.

### WHEN STARTING ENGINE

- Make sure spark plug, muffler, fuel cap and air cleaner are in place.
- Do not crank engine with spark plug removed.
- If fuel spills, wait until it evaporates before starting engine.
- If engine floods, set choke to OPEN/RUN position, place throttle in FAST and crank until engine starts.

### WHEN OPERATING EQUIPMENT

- Do not tip engine or equipment at angle which causes gasoline to spill.
- Do not choke carburetor to stop engine.

### WHEN TRANSPORTING EQUIPMENT

- Transport with fuel tank EMPTY or with fuel shut-off valve OFF.

### WHEN STORING GASOLINE OR EQUIPMENT WITH FUEL IN TANK

- Store away from furnaces, stoves, water heaters or other appliances that have pilot light or other ignition source because they can ignite gasoline vapors.



## WARNING

Engines give off carbon monoxide, an odorless, colorless, poison gas.

Breathing carbon monoxide can cause nausea, fainting or death.

- Start and run engine outdoors.
- Do not start or run engine in enclosed area, even if doors or windows are open.



## WARNING

Starting engine creates sparking.

Sparking can ignite nearby flammable gases.

Explosion and fire could result.



- If there is natural or LP gas leakage in area, do not start engine.
- Do not use pressurized starting fluids because vapors are flammable.



## WARNING

Running engines produce heat. Engine parts, especially muffler, become extremely hot.

Severe thermal burns can occur on contact.

Combustible debris, such as leaves, grass, brush, etc. can catch fire.



- Allow muffler, engine cylinder and fins to cool before touching.
- Remove accumulated combustibles from muffler area and cylinder area.
- Install and maintain in working order a spark arrester before using equipment on forest-covered, grass-covered, brush-covered unimproved land. The state of California requires this (Section 4442 of the California Public Resources Code). Other states may have similar laws. Federal laws apply on federal land.



## WARNING

Rotating parts can contact or entangle hands, feet, hair, clothing, or accessories.

Traumatic amputation or severe laceration can result.

- Operate equipment with guards in place.
- Keep hands and feet away from rotating parts.
- Tie up long hair and remove jewelry.
- Do not wear loose-fitting clothing, dangling drawstrings or items that could become caught.

# SAFETY



## WARNING



If engine is warm **DO NOT** remove radiator cap.  
Escaping steam can cause burns.

- Do not touch hot radiator, or open reservoir when engine is running
- Allow engine to cool before removing radiator cap, changing, or adding coolant.



## WARNING

Never remove radiator cap or radiator reservoir cap while the engine is hot or running. Severe thermal burns or injury can occur by escaping steam or hot engine coolant.

- Stop engine and allow to cool before removing radiator or reservoir cap.
- To remove reservoir cap after engine is cool, place a thick cloth over cap and remove it slowly.
- To remove radiator cap after engine is cool, place a thick cloth over cap and rotate it slowly counter-clockwise to the first stop. Pressurized steam may emit from the cap, stand back to avoid injury. Once all pressure is released, rotate cap counter-clockwise while pushing down on cap to remove.

## WARNING



Unintentional sparking can result in fire or electric shock.

Unintentional start-up can result in entanglement, traumatic amputation, or laceration.

## BEFORE PERFORMING ADJUSTMENTS OR REPAIRS

- Disconnect spark plug wire and keep it away from spark plug.
- Disconnect battery at negative terminal.

## WHEN TESTING FOR SPARK

- Use approved spark plug tester.
- Do not check for spark with spark plug removed.

## WARNING

Briggs & Stratton does not approve or authorize the use of these engines on 3-wheel All Terrain Vehicles (ATVs), motor bikes, fun/recreational go-karts, aircraft products or vehicles intended for use in competitive events. Use of these engines in such applications could result in property damage, serious injury (including paralysis), or even death.

# ENGINE INFORMATION



## TECHNICAL INFORMATION

### Engine Power Rating Information

The gross power rating for individual gas engine models is labeled in accordance with SAE (Society of Automotive Engineers) code J1940 (Small Engine Power & Torque Rating Procedure), and rating performance has been obtained and corrected in accordance with SAE J1995 (Revision 2002-05). Actual gross engine power will be lower and is affected by, among other things, ambient operating conditions and engine-to-engine variability. Given both the wide array of products on which engines are placed and the variety of environmental issues applicable to operating the equipment, the gas engine will not develop the rated gross power when used in a given piece of power equipment (actual "on-site" or net horsepower). This difference is due to a variety of factors including, but not limited to, accessories (air cleaner, exhaust, charging, cooling, carburetor, fuel pump, etc.), application limitations, ambient operating conditions (temperature, humidity, altitude), and engine-to-engine variability. Due to manufacturing and capacity limitations, Briggs & Stratton may substitute an engine of higher rated power for this Series engine.

## GENERAL INFORMATION

### ENGINE MODEL

This is a three cylinder, water cooled engine.

#### MODEL 430447, 433447

Bore ..... 68 mm (2.68 in.)

Stroke ..... 64 mm (2.52 in.)

Displacement ..... 697 cc (42.5 cu. in.)

#### MODEL 580447, 583447, 589447

Bore ..... 72 mm (2.834 in.)

Stroke ..... 78 mm (3.07 in.)

Displacement ..... 953 cc (58.1 cu. in.)

## TUNE-UP SPECIFICATIONS

Spark plug gap ..... 0.76 mm (0.030 in.)

Valve clearance (check when engine is cold).

Intake ..... 0.18 mm (0.007 in.)

Exhaust ..... 0.18 mm (0.007 in.)

# ENGINE INFORMATION

## ENGINE PARTS

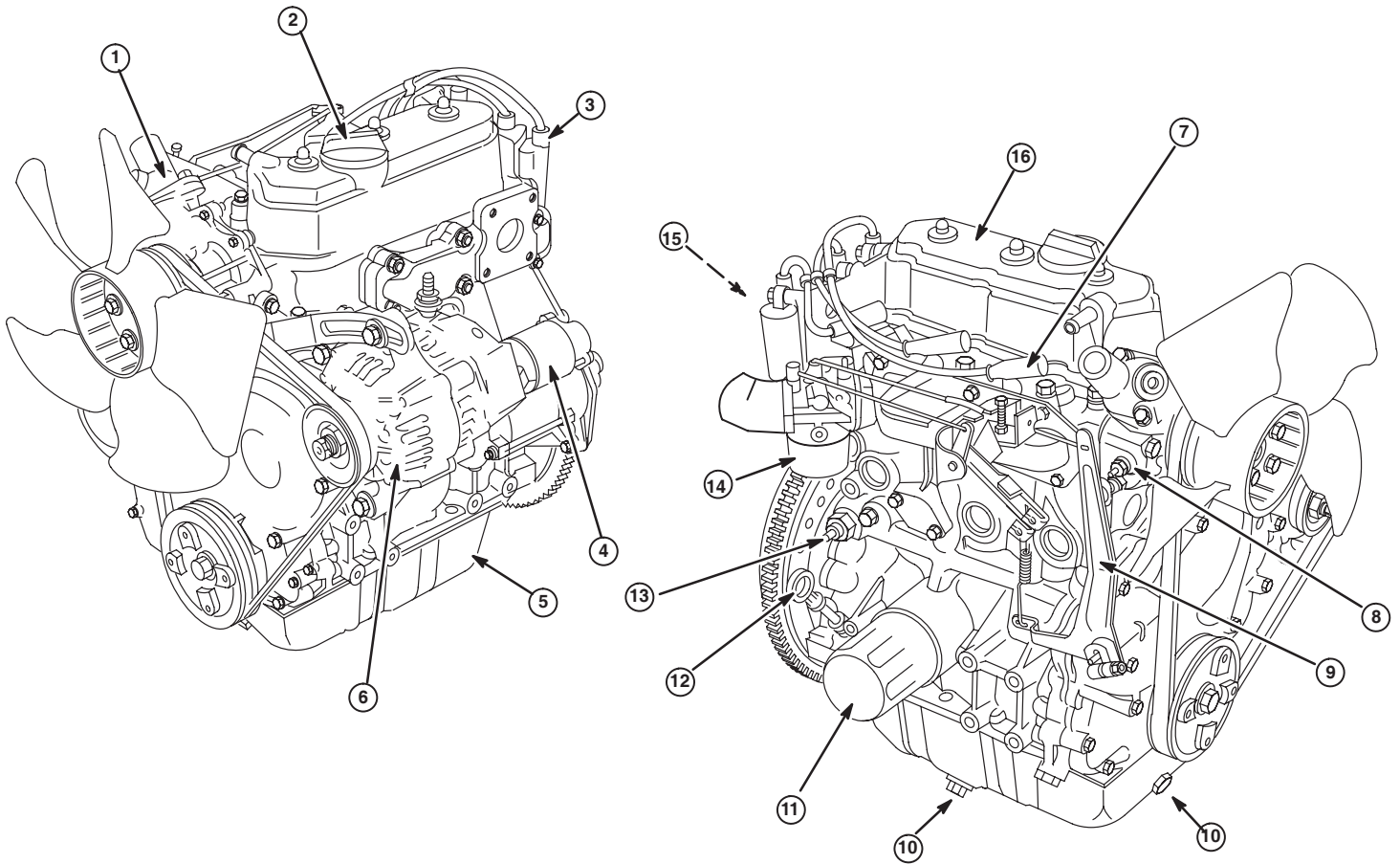

- |                                     |  |
|-------------------------------------|--|
| 1. Thermostat                       | 10. Oil drains                                   |
| 2. Oil filler cap                   | 11. Oil filter                                   |
| 3. Ignition coil                    | 12. Dipstick                                     |
| 4. Electric starter                 | 13. Oil pressure sending unit                    |
| 5. Oil pan                          | 14. Carburetor                                   |
| 6. Alternator                       | 15. Engine Date Code<br>xxxxxxx                  |
| 7. Spark plug                       | 16. Engine Model & Type number<br>xxxxxx xxxx-xx |
| 8. Coolant temperature sending unit |  |
| 9. Governor lever                   |  |





# FUEL



## TYPE OF FUEL TO USE

- Use clean, fresh, unleaded gasoline with a minimum of 85 octane. Fresh fuel prevents gum from forming in the fuel system or on essential carburetor parts. Purchase fuel in quantity that can be used within 30 days. In countries other than U.S.A., leaded gasoline may be used if it is commercially available and unleaded is unavailable.
- Do not use gasoline which contains Methanol.
- Do not mix oil with gasoline.
- **THIS ENGINE IS CERTIFIED TO OPERATE ON GASOLINE.**



## WARNING



- Fill fuel tank outdoors or in well-ventilated area, away from sparks, open flames, pilot lights, heat, and other ignition sources.
- If fuel spills, wait until it evaporates before starting engine.
- Turn engine OFF and let engine cool at least 2 minutes before removing gas cap.

## ADDING FUEL

[1]. Remove cap. Fill tank to approximately 1-1/2 inches below top of neck to allow for fuel expansion. Be careful not to overfill.

[2]. Replace cap before starting.

[3]. Check for fuel leaks at fuel filter, carburetor, fuel pump, fuel pipe, etc.

# COOLANT



## WARNING



- Do not touch radiator or open radiator cap, or open reservoir when engine is hot or running.
- Allow engine to cool before changing or adding coolant.

## SPECIFICATIONS

- This engine is water cooled.
- A 50/50% mixture is required of phosphate-free antifreeze and tap water for heat dissipation, rust resistance and lubrication.

## CHANGING & ADDING COOLANT

- Fill radiator to bottom of fill cap seat and between FULL and LOW in reservoir, if so equipped.

# GAUGES



## TYPICAL GAUGES (If Equipped)

### COOLANT TEMPERATURE GAUGE

Indicates coolant temperature when the starter switch is ON.

Normal range 80° – 90° C  
(175° – 195° F).

Dangerous range above 105° C  
(220° F).

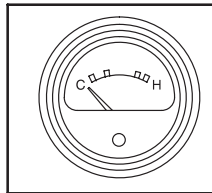

### HOUR METER

Indicates the total number of hours the engine has been run.

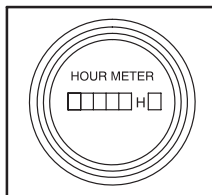

### FUEL GAUGE

To minimize condensation, keep fuel tank full.

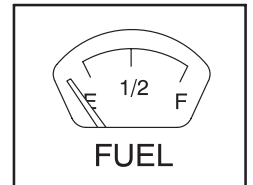

### FUEL SHUT-OFF

Open valve before starting engine.

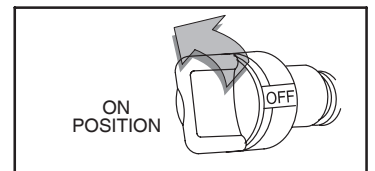

**CAUTION:** To prevent leaking, close fuel shut-off valve when engine is transported.

# GAUGES



## TYPICAL PANEL LIGHTS (If Equipped)

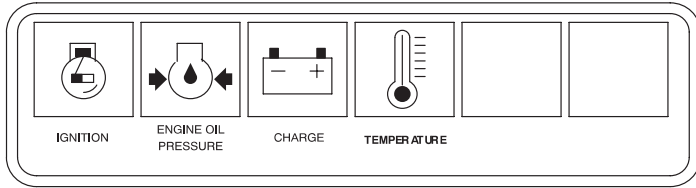

### Temperature light

If temperature light comes on, engine is overheating. Check:

- coolant level;
- debris on radiator or any restriction to air flow.

See an Authorized Briggs & Stratton 3/LC Service Dealer if necessary for operation repair.

## WARNING LIGHTS (Typical)

### Ignition light

The ignition light comes on when the starter switch is turned to the ON position, and should be out while engine is running. If ignition light goes out when starter switch is turned to the ON position, check fuse or bulb.

### Engine oil pressure light

The engine oil pressure light comes on when the starter switch is turned to the ON position and should be out while engine is running. If oil pressure light comes on while engine is running, stop engine immediately. Check oil level or electrical system.

### Charge light

The charge light comes on when the starter switch is turned to the ON position, but should be out while engine is running. If charge light comes on while engine is running, check electrical system.

# STARTING



## STARTING IN COLD WEATHER:

- ◆ Use correct type of oil for expected starting temperature. (See Oil.)
- ◆ Remove external equipment/engine loads. (See equipment operating instructions.)
- ◆ Periodically remove any debris buildup from the machine (See Maintenance.)
- ◆ Open fuel shut-off valve, if equipped, before starting engine.
- ◆ Pull choke and move throttle to FAST position.
- ◆ After engine has started, release key, which will return to ON position.
- ◆ Allow engine to warm up several seconds to several minutes, depending on outside temperature.
- ◆ Gradually open choke.
- ◆ Use fresh gasoline, which has higher volatility to improve starting.
- ◆ For maximum performance and life, operate engine with choke in OPEN and throttle in FAST.

**CAUTION:** Before starting engine for the first time, charge battery as the equipment manufacturer recommends. Failure to do so, may cause damage to the engine.



### WARNING

- The manufacturer of equipment on which this engine is installed specifies top speed at which engine will be operated. DO NOT EXCEED this speed.



### WARNING

- Do not use pressurized starting fluids.
- Vapors are flammable.
- Keep hands and feet clear of rotating machinery.



# STARTING & STOPPING



## TO START ENGINE



[1]. Insert key into starter switch at OFF position.

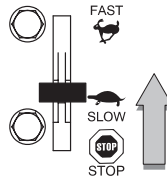

Typical throttle control

[2]. Open throttle control slightly.



Typical starter switch

[3]. Turn key to START.

**CAUTION:** To prolong starter life, use short starting cycles, not to exceed 15 secs/min. Extended cranking can damage starter motor. Follow equipment manufacturer's recommendations, if any.

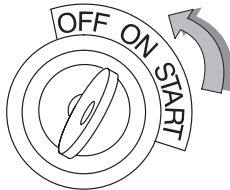

Typical starter switch

[4]. When engine starts, release key, which will return to ON position.

[5]. **NOTE:** If engine does not start immediately follow below:

### CHOKE OPERATION/ENGINE WARM-UP

- If engine does not start immediately, pull choke.
- After starting, allow engine to warm up a few minutes before applying load. Open choke gradually when applying load.

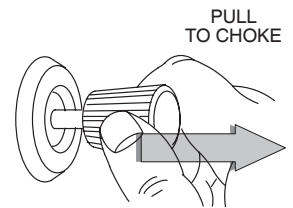

Typical choke control

## TO STOP ENGINE

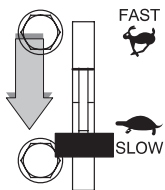

Typical throttle control

[1]. Move throttle to SLOW. Allow engine to run for short time to cool down.

**CAUTION:** Do not move choke control to CHOKE to stop engine. Backfire or engine damage may occur.

[2]. Turn key to OFF. Always remove key and store out of reach of children.

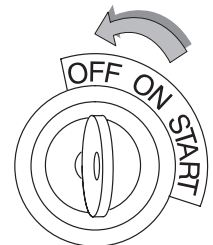

Typical starter switch

# MAINTENANCE



**REGULAR MAINTENANCE WILL IMPROVE THE PERFORMANCE AND EXTEND THE LIFE OF THE ENGINE. MORE FREQUENT SERVICE IS REQUIRED WHEN OPERATING IN ADVERSE CONDITIONS.**

See an Authorized Briggs & Stratton 3/LC Dealer for service. **Use only genuine Briggs & Stratton Parts. Other parts may not perform as well, may damage the engine, and may result in injury.** In addition, use of other parts may void your warranty.

Task <i>Perform task at hourly or calendar interval.</i>	Daily	50 Hours	100 Hours	150 Hours	200 Hours	600 Hours	Yearly
Check oil level	✓						
Check for oil leaks	✓						
Change oil and oil filter				✓*			
Check coolant	✓						
Change coolant							✓
Check fan belt			✓				
Service air cleaner			✓*			✓**	
Check valve clearance						✓	
Check battery electrolyte					✓		
Change spark plugs							✓
Change fuel filter						✓	
Clean spark arrestor (if equipped)		✓					

\* **Perform first maintenance operation after 50 hours.** All subsequent maintenance performed at this interval, unless specified. Service more often when operating under heavy load or in high temperatures.

\*\* Replace after every 600 hours of operation. Service more often when operating under heavy load or in high temperatures.

## DAILY CHECKS

### OIL

Before starting engine, check oil for correct level. See page 6 of this manual for instructions on checking and adding oil.

**CAUTION:** Used oil is a hazardous waste product. Dispose of used oil properly. Do not discard with household waste. Check with your local authorities, service center, or dealer for safe disposal/recycling facilities.

### CLEANING DEBRIS

Daily or before every use, clean accumulated debris from engine. Keep linkage, springs and controls clean.



**WARNING**



Engine parts should be kept clean to reduce the risk of overheating and ignition of accumulated debris.

**CAUTION:** Do not use water to clean engine parts. Water could contaminate fuel system. Use a brush or dry cloth.

### MUFFLER



**WARNING**



Before running engine, clean muffler and manifold areas to remove all grass and combustible debris. Depending on use, this may need to be performed more often.

## DAILY CHECKS continued



### **WARNING**

Never remove radiator cap or radiator reservoir cap while the engine is hot or running. Severe thermal burns or injury can occur by escaping steam or hot engine coolant.

- Stop engine and allow to cool before removing radiator or reservoir cap.
- To remove reservoir cap after engine is cool, place a thick cloth over cap and remove it slowly.
- To remove radiator cap after engine is cool, place a thick cloth over cap and rotate it slowly counter-clockwise to the first stop. Pressurized steam may emit from the cap, stand back to avoid injury. Once all pressure is released, rotate cap counter-clockwise while pushing down on cap to remove.

## COOLANT

Coolant level should be between FULL and LOW when engine is cold. If reservoir is dry, it must be filled along with radiator .

Check coolant level when engine is cold. If engine is warm DO NOT remove radiator cap.

### **WARNING**



Normal water temperature gauge should read between 175° and 195° F (80° and 90° C) when engine is running.

If water temperature rises above 220° F (105° C), idle engine down for a while. Then stop engine. Once engine is cooled, check coolant level, fan belt tension and clogged radiator fins.

## REGULAR MAINTENANCE

### **CHANGING OIL**

- [1]. Place engine level.
- [2]. Disconnect battery at negative terminal, and disconnect spark plug wires.
- [3]. With engine OFF but still warm remove oil drain plug and drain oil into appropriate receptacle.
- [4]. Reinstall drain plug and torque to 352 kg-cm (25.5 ft-lb).
- [5]. Refill engine with new oil. Fill to FULL mark on dipstick with new oil. Replace oil cap.  
**Caution: Do not overfill.**
- [6]. Start and run engine at idle for 5 minutes.
- [7]. Stop engine, and wait 3 minutes. Then re-check oil level.
- [8]. If required, add oil to bring level to **F** mark on dipstick.
- [9]. Check for leaks.

### **WARNING**



- Disconnect spark plug wires and keep it away from spark plugs.
- Disconnect battery at negative terminal.

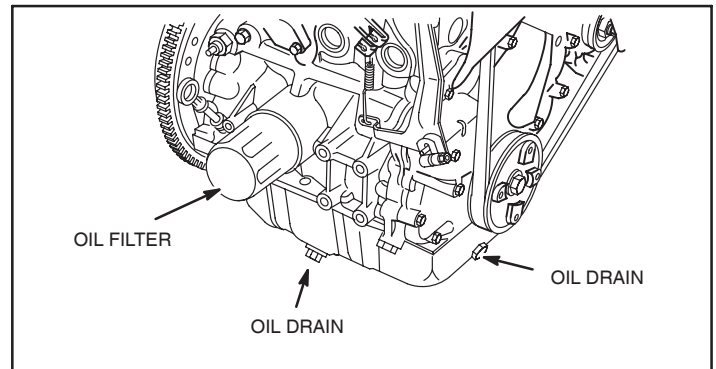

## REGULAR MAINTENANCE continued

### CHANGING OIL FILTER

- [1]. Perform this maintenance during oil change maintenance. Drain engine oil as described for oil change, and remove oil filter.
- [2]. Before installing new filter, apply to filter gasket fresh, clean oil.
- [3]. Screw filter on by hand until gasket contacts oil filter adapter. Tighten 1/2 to 3/4 turn more.
- [4]. Add fresh oil. Follow steps as described for oil change.
- [5]. Check for oil leaks around filter.

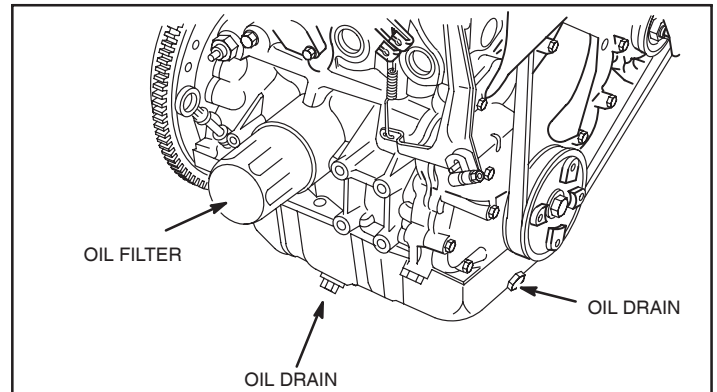

### AIR CLEANER

**Note:** Air cleaner may be supplied by equipment manufacturer.

#### Cartridge

To clean cartridge, gently tap on end with handle of screwdriver. Replace cartridge if very dirty or damaged.

**CAUTION:** Do not use pressurized air or solvents to clean cartridge. Pressurized air can damage cartridge; solvents will dissolve cartridge.

- [1]. Unlock clamps and remove cover.
- [2]. Remove cartridge from air cleaner body.
- [3]. Carefully clean out air cleaner cover.
- [4]. Install cartridge in body.
- [5]. Install cover and lock clamps.

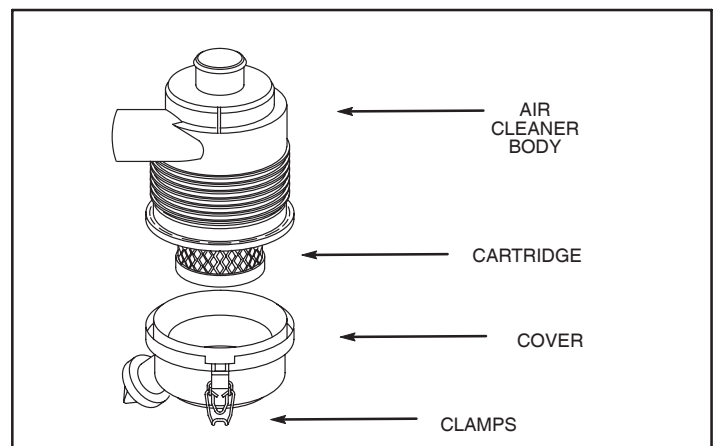

### SPARK PLUG

- ◆ Check and re-gap spark plugs if required.
- ◆ Replace if damaged.
- ◆ Use an approved spark tester to check for spark.

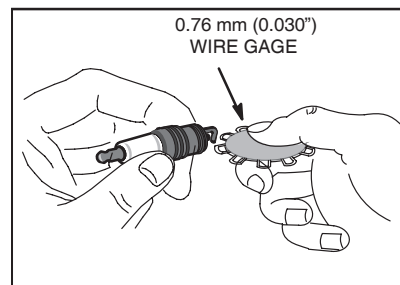

**Note:** In some areas, local law requires using resistor spark plug to suppress ignition signals. If this engine was originally equipped with resistor spark plug, use same type for replacement.

# MAINTENANCE



## VALVE CLEARANCE

With No. 1 piston at TDC of compression stroke, check valve clearances for cylinders shown in chart below. Rotate crankshaft 360° clockwise to check remaining valves. Adjust in same order, if required.

**Note:** If engine is running normally, this check and adjustment may be omitted.

- [1]. Loosen adjusting lock nut.
- [2]. Using a wrench to hold adjusting lock nut, adjust with screwdriver. Determine clearance using a feeler gauge.
- [3]. While holding screw driver in place, torque adjusting lock nut.

Valve clearances (cold):

**Int** 0.18 mm (0.007 in.)

**Exh** 0.18 mm (0.007 in.)

Adjusting lock nut torque: 110 kg-cm (95 in-lbs.)

Check valve cover gasket for leakage. Replace if required. Torque valve cover nuts to 55 kg-cm (48 in-lbs.)

Piston Position	Cylinder	1	2	3
No. 1 piston at TDC, of compression stroke	Int	•		•
	Exh	•	•	
Rotate Crankshaft 360° clockwise	Int		•	
	Exh			•

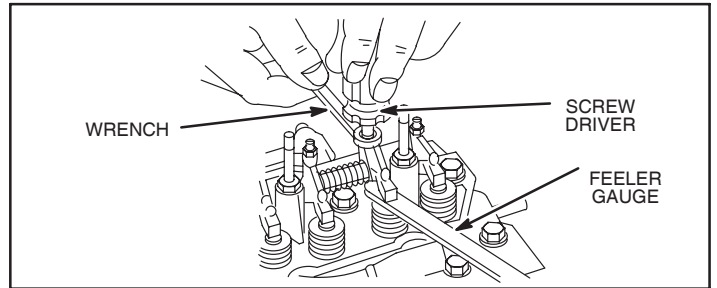

## FUEL FILTER

- [1]. Disconnect spark plug wires and keep away from spark plugs.
- [2]. When replacing fuel filter, ensure clamps are tight and fuel flows as shown.

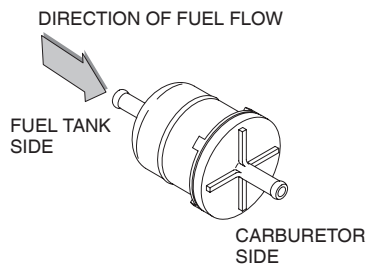

## WARNING



Drain fuel tank or close fuel shut-off valve before replacing fuel filter. Otherwise, fuel can leak out, creating a fire/explosion hazard.

## FAN BELT

- ◆ Check condition of fan belt.
- ◆ Replace if damaged or worn.

### To check for correct fan belt tension

When 10 kg (22 lbs.) of force is pressed at center of span between fan and alternator, there should be 10 to 12 mm (3/8 – 1/2 in.) of belt movement.

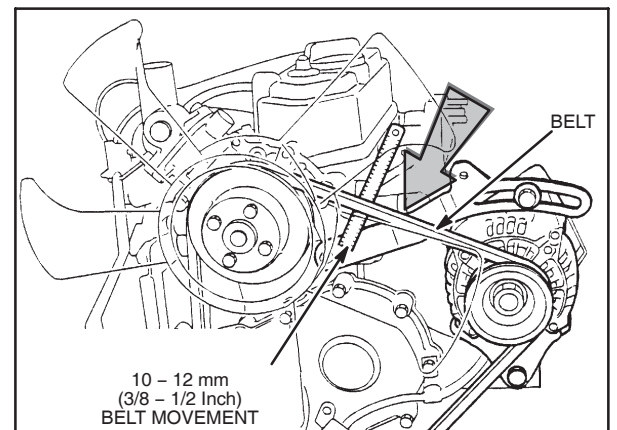

# MAINTENANCE



## To adjust for correct tension

- [1]. Loosen the 2 bolts (A) and (B).
- [2]. Place a handle (or similar object) between the alternator and engine cylinder block. Then move the alternator towards the outside of the engine, until the fan belt deflection conforms to the specified value.

### Specified fan belt deflection:

10 to 12mm / 10kg (3/8 to 1/2 in. / 22lbs.)

- [3]. Temporarily tighten the 2 bolts (A) and (B) to fix the alternator. Then remove the handle. Check fan belt deflection. If it is within specifications, permanently tighten the 2 bolts (A) and (B) as given below. If not, repeat the above adjustment procedure.

### Specified tightening torque:

(A) : 195 kg-cm (170 in-lbs)

(B) : 622 kg-cm (45 ft-lbs)

Check the fan belt deflection again.

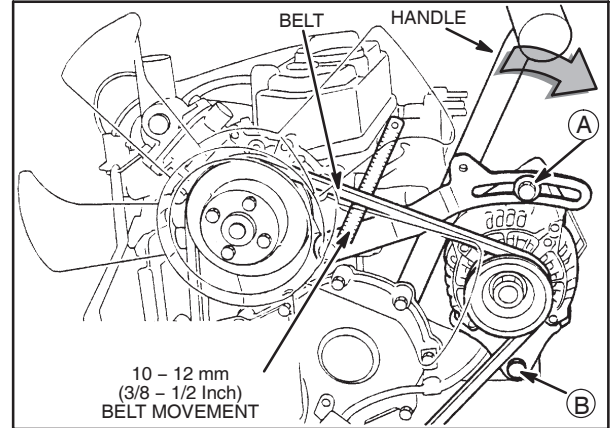

# ADJUSTMENTS



## CONTROL ADJUSTMENTS

If engine is hard to start or acceleration is uneven, check control operation and adjust if required as described below:

- [1]. Move throttle control to FAST position.
- [2]. Pull choke control to CHOKE position.

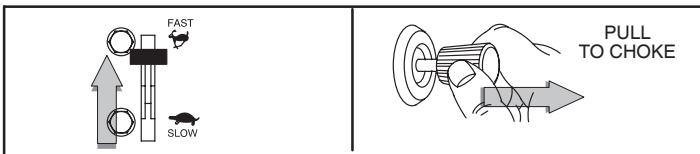

Typical throttle and choke controls

- [3]. Loosen casing clamp screw, then move wire and casing and engine choke lever in direction of arrow, until choke valve is completely closed.

### And/Or

- [4]. Move wire and casing and engine throttle lever in direction of arrow, until it touches high speed screw.
- [5]. Tighten casing clamp screw.

## WARNING



## BEFORE PERFORMING ADJUSTMENTS OR REPAIRS

- Disconnect spark plug wire and keep it away from spark plug.
- Disconnect battery at negative terminal.

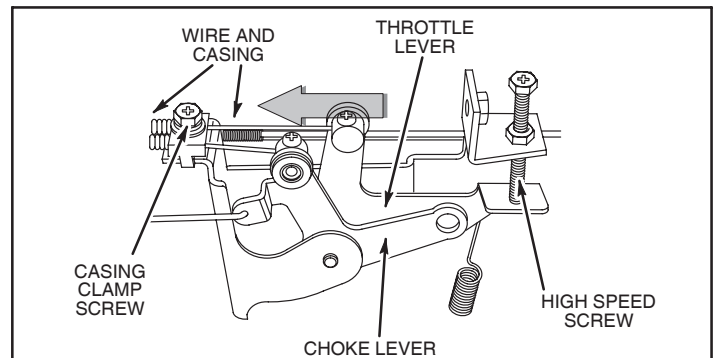

Choke and throttle control adjustment



# ADJUSTMENTS



## CARBURETOR ADJUSTMENTS

Differences in fuel, temperature, altitude or load may require minor carburetor adjustment. Air cleaner and air cleaner cover must be assembled to carburetor before starting engine.

The carburetor on this engine is low emission. It is equipped with an idle mixture valve with a limiter (see inset), which allows some adjustment, and an idle speed adjustment screw.

**Before adjustment, start and warm up engine approximately 5 minutes.**

- [1]. Place throttle control in IDLE or SLOW position.
- [2]. Rotate carburetor throttle lever against idle speed screw and hold.
- [3]. Adjust idle speed screw to obtain equipment manufacturer's specified idling speed.
- [4]. Turn idle mixture valve with limiter midway between limits.

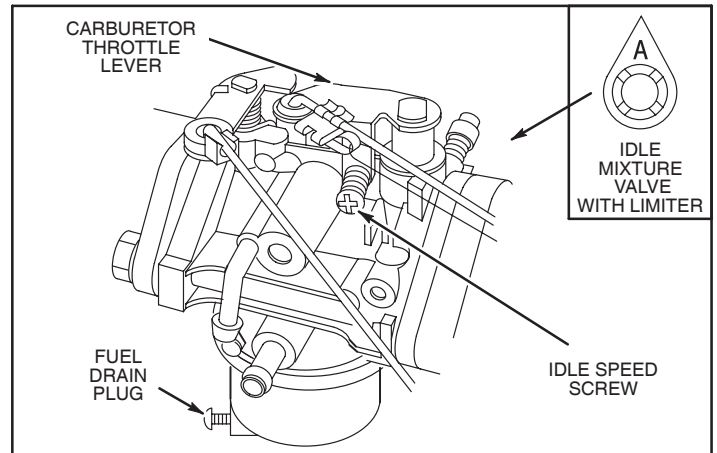

**Note:** Engines operated at approx. 900 to 1500 m. (3000 to 5000 ft.) or above sea level may require a high altitude carburetor main jet. If erratic performance is observed, contact an Authorized Briggs & Stratton 3/LC Service Dealer for a high altitude carburetor main jet.

# SERVICE



## PARTIAL LIST OF GENUINE BRIGGS & STRATTON PARTS

Part	Part No.
Oil .....	100028
Oil filter .....	491056
Oil filter (optional) .....	820314
Air filter .....	820263
Resistor spark plug	
430447, 433447 .....	491055
580447, 583447, 589447 .....	496018
Spark tester .....	19400
Fuel filter .....	821026
Gas additive .....	5041

You may locate your nearest Authorized Briggs & Stratton 3/LC Service Dealer by calling 1-800-233-3723.

## SERVICE

See an Authorized Briggs & Stratton 3/LC Service Dealer. Each one carries a stock of Genuine Briggs & Stratton 3/LC Parts and is equipped with special service tools. Only dealers advertising as Authorized Briggs & Stratton 3/LC Service Dealers are required to meet Briggs & Stratton standards.

When you purchase equipment powered by a Briggs & Stratton engine, you are assured of highly skilled, reliable service at any Authorized Service Dealers worldwide. Look for these signs wherever Briggs & Stratton service is offered.



The illustrated shop manual shown here includes common specifications and detailed information covering adjustment, tune-up and repair of B&S three cylinder, 4 cycle engines. It is available from an Authorized Briggs & Stratton Service Dealer.

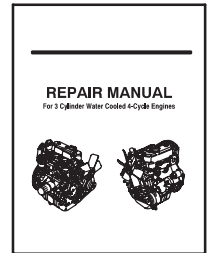

Part No. MS-0750

# STORAGE



Engines stored over 30 days need special attention.

- [1]. To prevent gum from forming in fuel system or on essential carburetor parts:
- a) if fuel tank contains oxygenated or reformulated gasoline (gasoline blended with an alcohol or an ether), run engine until it stops from lack of fuel, **or** b) if fuel tank contains gasoline, either run engine until it stops from lack of fuel, or add a gasoline additive to the gas in the tank. (See parts list. Single-use pouches of gas additive are available from your service dealer.) If you use a gas additive, run the engine for several minutes to circulate the additive through the carburetor. Then, engine and fuel can be stored up to 24 months.

- [2]. While engine is still warm, change oil.
- [3]. Remove spark plugs and pour about 30 ml (1 oz.) of engine oil into each cylinder. Replace spark plugs and crank slowly to distribute oil.
- [4]. Clean engine of surface debris, chaff or grass.

- [5].  **WARNING** Store in a clean, dry area. Do not store in same area as a stove, furnace, water heater, or other appliance that uses a pilot light or has a device that can create a spark.
- 

**For Model Series 430447, 433447, 580447 & 583447  
which are less than 19 Kw**

**Briggs & Stratton Corporation (B&S), the California Air Resources Board (CARB)  
and the United States Environmental Protection Agency (U.S. EPA)  
Emissions Control System Warranty Statement (Owner's Defect Warranty Rights and Obligations)**

EMISSIONS CONTROL WARRANTY COVERAGE IS APPLICABLE TO CERTIFIED MODEL YEAR 2002 AND LATER ENGINES, WHICH ARE PURCHASED AND USED IN CALIFORNIA, AND TO CERTIFIED MODEL YEAR

2002 AND LATER ENGINES, WHICH ARE PURCHASED AND USED ELSEWHERE IN THE UNITED STATES.

**California and United States Emissions Control Defects Warranty Statement**

The California Air Resources Board (CARB), U.S. EPA and B&S are pleased to explain the Emissions Control System Warranty on your model year 2002 and later small off-road engine (SORE). In California, new small off-road engines must be designed, built and equipped to meet the State's stringent anti-smog standards. Elsewhere in the United States, new small off-road engines certified for model year 2002 and later, must meet similar standards set forth by the U.S. EPA. B&S must warrant the emissions control system on your engine

for the period of time listed below, provided there has been no abuse, neglect or improper maintenance of your small off-road engine.

Your emissions control system includes parts such as the carburetor, air cleaner, ignition system, muffler and catalytic converter. Also included may be connectors and other emissions related assemblies.

Where a warrantable condition exists, B&S will repair your small off-road engine at no cost to you including diagnosis, parts and labor.

**Briggs & Stratton Corporation Emissions Control Defects Warranty Coverage**

Small off-road engines are warranted relative to emissions control parts defects for a period of two years, subject to provisions set forth below. If any

covered part on your engine is defective, the part will be repaired or replaced by B&S.

**Owner's Warranty Responsibilities**

As the small off-road engine owner, you are responsible for the performance of the required maintenance listed in your Operating & Maintenance Instructions. B&S recommends that you retain all your receipts covering maintenance on your small off-road engine, but B&S cannot deny warranty solely for the lack of receipts or for your failure to ensure the performance of all scheduled maintenance.

As the small off-road engine owner, you should however be aware that B&S may deny your warranty coverage if your small off-road engine or a part has failed due to abuse, neglect, improper maintenance or unapproved modifi-

cations.

You are responsible for presenting your small off-road engine to an Authorized B&S Service Dealer as soon as a problem exists. The undisputed warranty repairs should be completed in a reasonable amount of time, not to exceed 30 days.

If you have any questions regarding your warranty rights and responsibilities, you should contact a B&S Service Representative at 1-800-233-3723.

**EPA EMISSIONS COMPLIANCE PERIOD: 1000 Hours**

**CARB EMISSIONS COMPLIANCE PERIOD: 500 Hours**

**Briggs & Stratton Corporation Emissions Control Defects Warranty Provisions**

The following are specific provisions relative to your Emissions Control Defects Warranty Coverage. It is in addition to the B&S engine warranty for non-regulated engines found in the Operating & Maintenance Instructions.

**1. Warranted Parts**

Coverage under this warranty extends only to the parts listed below (the emissions control systems parts) to the extent these parts were present on the engine purchased.

**a. Fuel Metering System**

- Carburetor and internal parts
- Cold start enrichment system
- Fuel Pump
- Fuel Filter

**b. Air Induction System**

- Air cleaner
- Intake manifold

**c. Ignition System**

- Spark plug
- Ignition coil
- Ignition processor

**d. Exhaust System**

- Exhaust manifold

**e. Miscellaneous Items Used in Above Systems**

- Vacuum, temperature, position, time sensitive valves and switches
- Electronic Controls
- Connectors and assemblies
- Hoses

**2. Length of Coverage**

B&S warrants to the initial owner and each subsequent purchaser that the Warranted Parts shall be free from defects in materials and workmanship which caused the failure of the Warranted Parts for a period of two years from the date the engine is delivered to a retail purchaser.

**3. No Charge**

Repair or replacement of any Warranted Part will be performed at no charge to the owner, including diagnostic labor which leads to the determination that a Warranted Part is defective, if the diagnostic work is performed at an Authorized B&S Service Dealer. For emissions warranty service, contact your nearest Authorized B&S Service Dealer as listed in the "Yellow Pages" under "Lawn Mowers," "Engines, Gasoline," "Gasoline Engines" or similar category.

**4. Claims and Coverage Exclusions**

Warranty claims shall be filed in accordance with the provisions of the B&S Engine Warranty Policy. Warranty coverage shall be excluded for failures of Warranted Parts which are not original B&S parts or because of abuse, neglect or improper maintenance as set forth in the B&S Engine Warranty Policy. B&S is not liable to cover failures of Warranted Parts caused by the use of add-on, non-original, or modified parts.

**5. Maintenance**

Any Warranted Part which is not scheduled for replacement as required maintenance or which is scheduled only for regular inspection to the effect of "repair or replace as necessary" shall be warranted as to defects for the warranty period. Any Warranted Part which is scheduled for replacement as required maintenance shall be warranted as to defects only for the period of time up to the first scheduled replacement for that part. Any replacement part that is equivalent in performance and durability may be used in the performance of any maintenance or repairs. The owner is responsible for the performance of all required maintenance, as defined in the B&S Operating & Maintenance Instructions.

**6. Consequential Coverage**

Coverage hereunder shall extend to the failure of any engine components caused by the failure of any Warranted Part still under warranty.

**For Model Series 580447, 583447 & 589447  
Which are equal to or more than 19 kW**

**Briggs & Stratton Corporation (B&S), the California Air Resources Board (CARB)  
and the United States Environmental Protection Agency (U.S. EPA)  
Emissions Control System Warranty Statement  
(Owner's Warranty Rights and Obligations)**

EMISSIONS CONTROL WARRANTY COVERAGE IS APPLICABLE TO CERTIFIED MODEL YEAR 2004 AND LATER ENGINES, WHICH ARE PURCHASED AND USED IN CALIFORNIA, AND TO CERTIFIED MODEL

YEAR 2004 AND LATER ENGINES, WHICH ARE PURCHASED AND USED ELSEWHERE IN THE UNITED STATES.

**California and United States Emissions Control Warranty Statement**

The California Air Resources Board (CARB), U.S. EPA and B&S are pleased to explain the Emissions Control System Warranty on your model year 2004 and later off-road spark-ignition engine over 19kW (25HP). In California, new off-road large spark-ignition engines must be designed, built and equipped to meet the State's stringent anti-smog standards. Elsewhere in the United States, new Non-road spark-ignition engines over 19kW certified for model year 2004 and later, must meet similar standards set forth by the U.S. EPA. B&S must warrant the emissions control system on your engine for the period

of time listed below, provided there has been no abuse, neglect or improper maintenance of your engine.

Your emissions control system includes parts such as the carburetor, air cleaner, ignition system, muffler, and catalytic converter. Also included may be hoses, belts, connectors and other emissions related assemblies.

Where a warrantable condition exists, B&S will repair your engine at no cost to you including diagnosis, parts and labor.

**Briggs & Stratton Corporation Emissions Control Warranty Coverage**

The 2004 and later off-road spark-ignition engines are warranted for two years.

If any emissions-related part on your engine is defective, the part will be repaired or replaced by B&S.

**Owner's Warranty Responsibilities**

As the engine owner, you are responsible for the performance of the required maintenance listed in your Operating & Maintenance Instructions. B&S recommends that you retain all your receipts covering maintenance on your engine, but B&S cannot deny warranty solely for the lack of receipts or for your failure to ensure the performance of all scheduled maintenance.

As the engine owner, you should however be aware that B&S may deny you warranty coverage if your engine or a part has failed due to abuse, neglect, improper maintenance or unapproved modifications. You are responsible for presenting your engine to an Authorized B&S Service Dealer as soon as a problem exists. The warranty repairs should be completed in a reasonable amount of time, not to exceed 30 days. If you have questions regarding your warranty rights and responsibilities, you should contact a B&S Service Representative at 1-800-233-3723.

**EMISSIONS COMPLIANCE PERIOD: 1000 HOURS**

**Briggs & Stratton Corporation Emissions Control Warranty Provisions**

The following are specific provisions relative to your Emissions Control Warranty Coverage. It is in addition to the B&S engine warranty for non-regulated engines found in the Operating & Maintenance Instructions.

1. **Warranted Parts**  
Coverage under this warranty extends only to the parts listed below (the emissions control systems parts) to the extent these parts were present on the engine purchased.
  - a. **Fuel Metering System**  
Carburetor and internal parts  
Cold start enrichment system  
Fuel pump  
Fuel filter
  - b. **Air Induction System**  
Air cleaner  
Intake manifold
  - c. **Ignition System**  
Spark plug  
Ignition coil  
Ignition processor
  - d. **Exhaust System**  
Exhaust manifold
  - e. **Miscellaneous Items Used in Above System**  
Vacuum, temperature, position, time sensitive valves and switches  
Electronic controls  
Connectors and assemblies  
Hoses
2. **Length of Coverage**  
B&S warrants to the initial owner and each subsequent purchaser that the Warranted Parts shall be free from defects in materials and workmanship which caused the failure of the Warranted Parts for a period of two years from the date the engine is delivered to a retail purchaser.

3. **No Charge**  
Repair or replacement of any Warranted Part will be performed at no charge to the owner, including diagnostic labor which leads to the determination that a Warranted Part is defective, if the diagnostic work is performed at an Authorized B&S Service Dealer. For emissions warranty service, contact your nearest Authorized B&S Service Dealer as listed in the "Yellow Pages" under "Engines, Gasoline," "Gasoline Engines," "Lawn Mowers," or similar category.
4. **Claims and Coverage Exclusions**  
Warranty claims shall be filed in accordance with the provisions of the B&S Engine Warranty Policy. Warranty coverage shall be excluded for failures of Warranted Parts which are not original B&S parts or because of abuse, neglect or improper maintenance as set forth in the B&S Engine Warranty Policy. B&S is not liable to cover failures of Warranted Parts caused by the use of add-on, non-original, or modified parts.
5. **Maintenance**  
Any Warranted Part which is not scheduled for replacement as required maintenance or which is scheduled only for regular inspection to the effect of "repair or replace as necessary" shall be warranted as to defects for the warranty period. Any Warranted Part which is scheduled for replacement as required maintenance shall be warranted as to defects only for the period of time up to the first scheduled replacement for that part. Any replacement part that is equivalent in performance and durability may be used in the performance of any maintenance or repairs. The owner is responsible for the performance of all required maintenance, as defined in the B&S Operating & Maintenance Instructions.
6. **Consequential Coverage**  
Coverage hereunder shall extend to the failure of any engine components caused by the failure of any Warranted Part still under warranty.

# BRIGGS & STRATTON 3/LC ENGINE OWNER WARRANTY POLICY

Effective January 1, 2006 replaces all undated Warranties and all Warranties dated before January 1, 2006

## LIMITED WARRANTY

Briggs & Stratton Corporation (B&S) will repair or replace, free of charge, any part(s) of the engine that is defective in material or workmanship or both. Transportation charges on parts submitted for repair or replacement under this warranty must be borne by purchaser. This warranty is effective for the time periods and subject to the conditions stated below. For warranty service, find the nearest Authorized Briggs & Stratton 3/LC Service Dealer in our dealer locator map at [www.briggsandstratton.com](http://www.briggsandstratton.com), or by calling 1-800-233-3723, or as listed in the 'Yellow Pages'™.

THERE IS NO OTHER EXPRESS WARRANTY. IMPLIED WARRANTIES, INCLUDING THOSE OF MERCHANTABILITY AND FITNESS FOR A PARTICULAR PURPOSE, ARE LIMITED TO ONE YEAR FROM PURCHASE, OR TO THE EXTENT PERMITTED BY LAW ANY AND ALL IMPLIED WARRANTIES ARE EXCLUDED. LIABILITY FOR INCIDENTAL OR CONSEQUENTIAL DAMAGES ARE EXCLUDED TO THE EXTENT EXCLUSION IS PERMITTED BY LAW. Some states or countries do not allow limitations on how long an implied warranty lasts, and some states or countries do not allow the exclusion or limitation of incidental or consequential damages, so the above limitation and exclusion may not apply to you. This warranty gives you specific legal rights and you may also have other rights which vary from state to state and country to country.

## OUR PRODUCT

VANGUARD™ 3/LC Engine	Major Parts Warranty*	Parts & Labor*
--------------------------	-----------------------	----------------

## WARRANTY PERIOD

Consumer and Commercial Use	2 years	3 years	2 years
-----------------------------	---------	---------	---------

\* **Note the following special warranty periods:** For purposes of this warranty policy, Parts and Labor coverage is 2 years. Major parts only coverage is extended to through the third year of operation. **Major Parts Warranty (M.P.W.) covers** but is not limited to or exclusive to cylinder block, cylinder head, crankshaft, camshaft, gears, pistons, rods, flywheel, flywheel housing, oil pump, fan, pulleys, mechanical governor, intake manifold, oil pan. **M.P.W. does not cover** and is not limited to piston rings, replaceable bearings, water pump, any electrical component, valve train components, accessory parts, seals, gaskets, carburetors, exhaust manifold, hoses, all fuel system components, injectors, injection pump, turbocharger, muffler, any filters, radiator, thermostat, spark plugs, glow plugs, fuel transfer pumps. The warranty period begins on the date of purchase by the first retail consumer or commercial end user, and continues for the period of time stated in the table above.

**NO WARRANTY REGISTRATION IS NECESSARY TO OBTAIN WARRANTY ON B&S ENGINES. SAVE YOUR PROOF OF PURCHASE RECEIPT. IF YOU DO NOT PROVIDE PROOF OF THE INITIAL PURCHASE DATE AT THE TIME WARRANTY SERVICE IS REQUESTED, THE MANUFACTURING DATE OF THE PRODUCT WILL BE USED TO DETERMINE THE WARRANTY PERIOD.**

## ABOUT YOUR ENGINE WARRANTY

B&S welcomes warranty repair and apologizes to you for being inconvenienced. Any Authorized Briggs & Stratton 3/LC Service Dealer may perform warranty repairs. Most warranty repairs are handled routinely, but sometimes requests for warranty service may not be appropriate. For example, warranty would not apply if engine damage occurred because of misuse, lack of routine maintenance, shipping, handling, warehousing or improper installation. Similarly, warranty is void if the serial number of the engine has been removed or the engine has been altered or modified.

If a customer differs with the decision of the Service Dealer, an investigation will be made to determine whether the warranty applies. Ask the Service Dealer to submit all supporting facts to the Distributor or the Factory for review. If the Distributor or the Factory decides that the claim is justified, the customer will be fully reimbursed for those items that are defective. To avoid misunderstanding which might occur between the customer and the Dealer, listed below are some of the causes of engine failure that the warranty does not cover.

### Normal wear:

Engines, like all mechanical devices, need periodic parts service and replacement to perform well. Warranty will not cover repair when normal use has exhausted the life of a part or an engine.

### Improper maintenance:

The life of an engine depends upon the conditions under which it operates, and the care it receives. Some applications, such as tillers, pumps and rotary mowers, are very often used in dusty or dirty conditions, which can cause what appears to be premature wear. Such wear, when caused by dirt, dust, spark plug cleaning

grit, or other abrasive material that has entered the engine because of improper maintenance, is not covered by warranty.

**This warranty covers engine related defective material and/or workmanship only, and not replacement or refund of the equipment to which the engine may be mounted. Nor does the warranty extend to repairs required because of:**

1. Engines that are not properly applied to equipment. It is strongly recommended that the factory be contacted prior to applying a B&S 3/LC engine to equipment that did not originally use a B&S 3/LC engine.
2. PROBLEMS CAUSED BY PARTS THAT ARE NOT ORIGINAL BRIGGS & STRATTON PARTS.
3. Equipment controls or installations that prevent starting, cause unsatisfactory engine performance, or shorten engine life. (Contact equipment manufacturer.)
4. Leaking carburetors, clogged fuel pipes or injectors, sticking valves, contaminated injection pumps, or other damage, caused by using contaminated or stale fuel. Use clean, fresh fuel (lead free gasoline, diesel fuel) and Briggs & Stratton fuel stabilizer, Part No. 5041.
5. Parts which are scored or broken because an engine was operated with insufficient or contaminated lubricating oil, or an incorrect grade of lubricating oil (check oil level daily or after every 8 hours of operation. Refill when necessary and change oil and oil filter at recommended intervals.) OIL GARD may not shut down running engine. Engine damage may occur if oil level is not properly maintained. Read Operating & Maintenance Instructions.

6. Repair or adjustment of associated parts or assemblies such as clutches, transmissions, remote controls, etc., which are not manufactured by B&S.
7. Damage or wear to parts caused by dirt, which entered the engine because of improper air cleaner maintenance, re-assembly, or use of a non-original air cleaner element or cartridge. (At recommended intervals, replace cartridge.) Read Operating & Maintenance Instructions.
8. Parts damaged by over-speeding, or overheating caused by grass, debris, or dirt, which plugs, clogs radiator or air cooling access openings, or damage caused by operating the engine in a confined area without sufficient ventilation. Engine damage caused by not using accurate mix of anti-freeze and tap water, or water entering the engine due to any cause.
9. Engine or equipment parts broken by excessive vibration caused by a loose engine mounting, loose cutter blades, unbalanced blades or loose or unbalanced impellers, improper attachment of equipment to engine crankshaft, over-speeding or other abuse in operation.
10. Routine tune-up or adjustment of the engine.
11. Engine or engine component failure, i.e., combustion chamber, valves, valve seats, valve guides, or burned starter motor windings, caused by the use of alternate fuels such as, liquified petroleum, natural gas, altered gasolines, etc.

**Warranty is available only through service dealers which have been authorized by Briggs & Stratton. Locate your nearest Authorized B&S 3/LC Service Dealer through our dealer locator map on [www.briggsandstratton.com](http://www.briggsandstratton.com).**



**THE POWER WITHIN™**