

dual alarm clock radio

owners manual

SAVE THIS USE AND CARE BOOK



PHILIPS CONSUMER ELECTRONICS COMPANY

A Division of Philips Electronics North America Corporation
Knoxville, Tennessee 37914-1810, U.S.A.

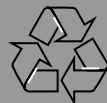

Meet PHILIPS at the Internet <http://www.philipsusa.com>

MG-C200
MG-C205

Printed in Hong Kong

SAFETY

Know these *safety* symbols



This "bolt of lightning" indicates uninsulated material within your unit may cause an electrical shock. For the safety of everyone in your household, please do not remove product covering.



The "exclamation point" calls attention to features for which you should read the enclosed literature closely to prevent operating and maintenance problems.

WARNING: TO PREVENT FIRE OR SHOCK HAZARD, DO NOT EXPOSE THIS EQUIPMENT TO RAIN OR MOISTURE.

CAUTION: To prevent electric shock, match wide blade of plug to wide slot, and fully insert.

CANADA

English: This digital apparatus does not exceed the Class B limits for noise emissions from digital apparatus as set out in the Radio Interference Regulations of the Canadian Department of Communications.

Français: Cet appareil numérique n'émet pas de bruits radioélectriques dépassant les limites applicables aux appareils numériques de Classe B prescrites dans le Règlement sur le Brouillage Radioélectrique édicté par le Ministère des Communications du Canada.

IMPORTANT SAFETY INSTRUCTIONS – Read before operating equipment

This product was designed and manufactured to meet strict quality and safety standards. There are, however, some installation and operation precautions which you should be particularly aware of.

- 1. Read these instructions** – All the safety and operating instructions should be read before the appliance is operated.
- 2. Keep these instructions** – The safety and operating instructions should be retained for future reference
- 3. Heed all warnings** – All warnings on the appliance and in the operating instructions should be adhered to.
- 4. Follow all instructions** – All operating and use instructions should be followed
- 5. Do not use this apparatus near water** – for example, near a bathtub, washbowl, kitchen sink, laundry tub, in a wet basement or near a swimming pool, etc.
- 6. Clean only with a damp cloth.** The appliance should be cleaned only as recommended by the manufacturer
- 7. Install in accordance with the manufacturers instructions. Do not block any of the ventilation openings.** For example, the appliance should not be situated on a bed, sofa, rug, or similar surface or placed in a built-in installation, such as a bookcase or cabinet that may impede the flow of air through the ventilation openings.
- 8. Do not install near any heat sources** such as radiators, heat registers, stoves, or other apparatus (including amplifiers) that produce heat

- 9. Do not defeat the safety purpose** of the polarized or grounding-type plug. A polarized plug has two blades with one wider than the other. A grounding type plug has two blades and a third grounding prong. The wide blade or the third prong are provided for your safety. When the provided plug does not fit into your outlet, consult an electrician for replacement of the obsolete outlet.

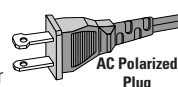

- 10. Protect the power cord** from being walked on or pinched particularly at plugs, convenience receptacles, and the point where they exit from the apparatus
- 11. Only use attachments/accessories** specified by the manufacturer
- 12. Use only with a cart, stand, tripod, bracket, or table** specified by the manufacturer, or sold with the apparatus. When a cart is used, use caution when moving the cart/apparatus combination to avoid injury from tip-over
- 13. Unplug this apparatus** during lightning storms or when unused for long periods of time
- 14. Refer all servicing** to qualified service personnel. Servicing is required when the apparatus has been damaged in any way, such as power-supply cord or plug is damaged, liquid has been spilled or objects have fallen into the apparatus, the apparatus has been exposed to rain or moisture, does not operate normally, or has been dropped

EL 4562-E004: 99/3

CONTROLS

- 1 SLEEP/ RADIO ON**
 - displays/ adjusts/ switches off sleep time
 - switches on radio; displays radio frequency
- 3 SNOOZE/ BRIGHTNESS CONTROL**
 - switches off the alarm for 9 minutes period
 - changes the brightness of the display illumination
- ALARM RESET/ RADIO OFF**
 - stops the active alarm for 24 hours
 - stops radio /sleep function
- BAND**
 - selects FM/AM waveband
- TIME SET/ TUNING: < MIN and HR >**
 - adjusts the hours (HR >) and minutes (< MIN) for clock/ alarm times
 - tunes (< , >) to radio stations
- PRESET 3, 4 and 5**
 - stores and selects preset stations
- Display**
 - shows the clock/ alarm times and status of the set
- ALARM 2 - BUZZ** and also **PRESET 2**
 - selects buzzer mode on or off for alarm 2
 - stores and selects **PRESET station 2**
- ALARM 1 - RADIO** and also **PRESET 1**
 - selects radio mode on or off for alarm 1
 - stores and selects **PRESET station 1**
- VOLUME**
 - adjusts the sound level
- SET control**
 - sets the times for •ALARM 1, •ALARM 2, •TIME and to **RUN** on clock time
- Power cord**
 - for AC power supply and improve FM reception

The type plate is located on the bottom of the set.

Environmental information

All unnecessary packaging material has been omitted to make the packaging easy to separate into two materials: paper (box and paper pulp), polyethylene (bags, protective foam).

Your set consists of materials, which can be recycled if disassembled by a specialized company. Please observe the local regulations to dispose of packing materials, dead batteries and old equipment.

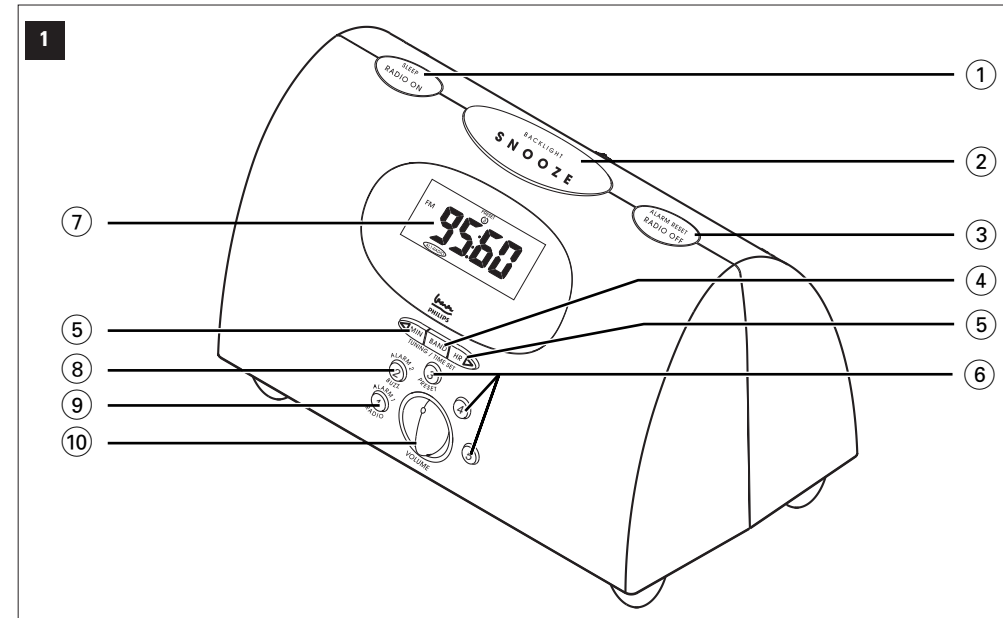

INSTALLATION

POWER SUPPLY AND DEMO MODE

- Check if the power voltage, shown on the type plate on the bottom of the set, corresponds to your local power supply. If it does not, consult your dealer or service centre.
- Connect the power plug to the wall outlet. The power supply is now switched on and the display will show the **PHILIPS demo mode**.
- PH..IL .LIPS** scrolls across the display continuously.
- Turn the **SET control** to **SET TIME** to exit the demo mode.
- To disconnect the set completely from the power supply, withdraw the power plug from the wall outlet.

POWER BACK-UP

The power back-up conveniently allows your preset stations, alarm and clock time settings to be stored for up to 3 minutes when there is a power interruption e.g. AC mains failure. The complete clock radio and display illumination will be switched off. As soon as the power supply returns, the display will indicate the correct time.

BASIC FEATURES

If power supply returns after 3 minutes and the display shows:

- clock time blinking** – indicates you need to re-adjust the clock time
- PHILIPS demo mode** – indicates you need to re-enter preset stations and the clock and alarm times.

ILLUMINATION BRIGHTNESS

- Check if the **SET control** is turned to **CLOCK** position and the radio is switched off.
- Press **SNOOZE/ BRIGHTNESS CONTROL** once or more.
 - The brightness of the display will change in this sequence: **BRIGHT → MEDIUM → LOW → BRIGHT...**

Note: when an alarm or the **SLEEP** function is active, brightness cannot be adjusted.

RESET

Should the display and electronic functions of your set receive interference e.g. static electricity from carpets, thunderstorms, etc. **RESET** allows you to clear all previous settings and start up again.

- Use a ballpoint pen to press the **RESET** hole found on the bottom of the set.

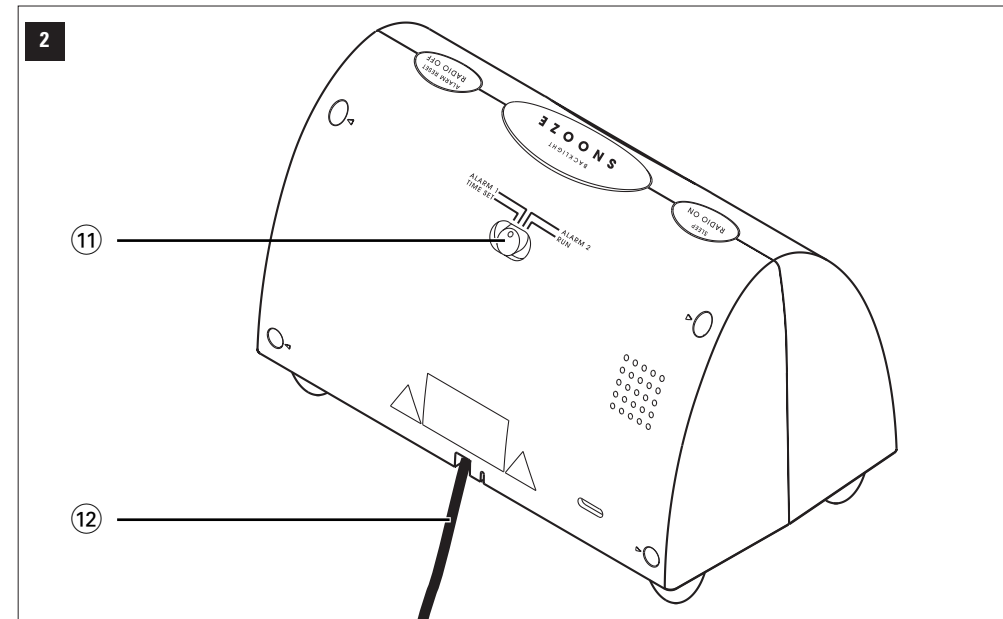

→ Both the model number and production number are on the bottom of the set.

SETTING THE CLOCK

The time is displayed using the 12 hour clock with PM indicator (PM off = AM).

1. Turn the SET control to TIME SET.
2. Press **HR** ▷ repeatedly or hold down on the button to adjust the hours. Release **HR** ▷ when you reach the correct hour.
3. Press ◁ **MIN** repeatedly or hold down on the button to adjust the minutes. Release ◁ **MIN** when you reach the correct minute setting.
4. Turn the SET control to RUN.

RADIO

1. Press SLEEP/ RADIO ON once to switch on the radio. → Display shows the radio frequency of the last selected waveband briefly before returning to the clock time. Your preset station is also shown if you are listening to a preset.
2. Press BAND if you wish to change waveband.
3. Adjust the sound using VOLUME.
4. Press ALARM RESET/ RADIO OFF to switch off.

The set complies with the FCC-Rules, Part 15.

Operation is subject to the following two conditions:

1. *This device may not cause harmful interference, and*
2. *This device must accept any interference received, including interference that may cause undesired operation.*

RADIO

Automatic tuning

- Press **HR** ▷ or ◁ **MIN** one second or more to tune to your station. → The radio automatically tunes to a station of sufficient reception.

Manual tuning

- Press **HR** ▷ or ◁ **MIN** briefly and repeatedly until your reach the desired frequency.

To improve reception:

FM: Adjust the position of the power cord (built-in antenna) for optimum reception.

AM: Uses a built-in antenna inside the set. Direct the antenna by adjusting the position of your set.

SETTING THE ALARM

Notes: *If you have selected the ALARM 1 RADIO, make sure you have properly tuned to a station before turning off the set.*

If you set and activate the same alarm time for both alarms, only the ALARM 2-BUZZ will be activated at the set time.

SWITCHING OFF THE ALARM

There are three ways of switching off the alarm. Unless you cancel the alarm completely, the *24 hour alarm reset* option will be automatically selected after 59 minutes, from the time your alarm time first goes off.

24 hour alarm reset

If you want the alarm mode to be stopped immediately but also wish to retain the same alarm setting for the following day:

- Press ALARM RESET/ RADIO OFF. → You will hear a beep tone confirming 24 hour reset activation.



Cancelling the alarm completely

To cancel the set alarm time before it goes off, or during the alarm call:

- With the radio switched off, press ALARM 1-RADIO or ALARM 2-BUZZ once or more until the selected alarm indicator disappears from the display.

Repeat alarm

This repeats your alarm call at 9-minute intervals.

1. During the alarm call, press SNOOZE/ BRIGHTNESS CONTROL. → Display shows  or  flashing during a repeat alarm.
2. Repeat if desired up to 6 times.

ABOUT SLEEP

This set has a built-in sleep timer which enables the set to be automatically switched off during radio playback after a set period of time. There are four sleep times before the set turns itself off: 60, 30, 15 minutes and off.

TROUBLESHOOTING

If a fault occurs, first check the points listed below before taking the set for repair. If you are unable to remedy a problem by following these hints, consult your dealer or service center.

WARNING: *Under no circumstances should you try to repair the set yourself, as this will invalidate the warranty.*

PROBLEM

– POSSIBLE CAUSE

- REMEDY

No sound

– Volume not adjusted

- Adjust the VOLUME

Display error/ no reaction to any controls

– Electrostatic discharge

- Press RESET

Occasional crackling sound during FM broadcast

– Weak signal

- Adjust the position of the pigtail aerial

Continuous crackling/

hiss disturbance during MW (AM) broadcast

– Electrical interference from TV, computer, fluorescent lamp, mobile phone, etc.

- Move set away from other electrical equipment

The alarm does not function

– Alarm time/mode not set

- See SETTING THE ALARM

– Volume too low for ALARM 1-RADIO

- Adjust the volume

– ALARM 1-RADIO not tuned to a radio station

- Check if the set is tuned to a radio station before setting the ALARM 1-RADIO, and when switching off

LIMITED WARRANTY

PORTABLE AUDIO

90 days Free Exchange

This product must be carried in for an exchange.

WHO IS COVERED?

You must have proof of purchase to exchange the product. A sales receipt or other document showing that you purchased the product is considered proof of purchase. Attach it to this owner's manual and keep both nearby.

WHAT IS COVERED?

Warranty coverage begins the day you buy your product. For 90 days thereafter, a defective or inoperative product will be replaced with a new, renewed or comparable product at no charge to you. A replacement product is covered only for the original warranty period. When the warranty on the original product expires, the warranty on the replacement product also expires.

WHAT IS EXCLUDED?

Your warranty does not cover:

- labor charges for installation or setup of the product, adjustment of customer controls on the product, and installation or repair of antenna systems outside of the product.
- product repair and/or part replacement because of misuse, accident, unauthorized repair or other cause not within the control of Philips Consumer Electronics Company.
- reception problems caused by signal conditions or cable or antenna systems outside the unit.

- a product that requires modification or adaptation to enable it to operate in any country other than the country for which it was designed, manufactured, approved and/or authorized, or repair of products damaged by these modifications.
- incidental or consequential damages resulting from the product. (Some states do not allow the exclusion of incidental or consequential damages, so the above exclusion may not apply to you. This includes, but is not limited to, prerecorded material, whether copyrighted or not copyrighted.)
- a product used for commercial or institutional purposes.

WHERE IS EXCHANGE AVAILABLE?

You may exchange the product in all countries where the product is officially distributed by Philips Consumer Electronics Company. In countries where Philips Consumer Electronics Company does not distribute the product, the local Philips service organization will attempt to provide a replacement product (although there may be a delay if the appropriate product is not readily available).

BEFORE REQUESTING EXCHANGE...

Please check your owner's manual before requesting an exchange. Adjustments of the controls discussed there may save you a trip.

RADIO

STORING AND USING PRESET STATIONS

You can store up to a total of 10 radio stations in the memory, 5 on each waveband.

1. Tune to your desired station (see TUNING TO RADIO STATIONS).
2. To store a preset, hold down briefly on a PRESET button 1-5 until you hear a double beep. → Display shows the preset number of your station.
3. Repeat steps 1 and 2 to store your other stations.
 - You can overwrite a preset station by storing another frequency in its place.
4. Press a PRESET button 1-5 to listen to a preset station.





SETTING THE ALARM

GENERAL

Two different alarm times can be set. This can be useful when you need to be woken up at a different time e.g. during the week and at the weekend:



- ALARM 1 – *radio mode*
- ALARM 2 – *buzzer mode*. The *gentle wake* buzzer alarm increases its beep tone frequency within seconds.

SETTING THE ALARM TIME AND MODE

1. Turn the SET control to ALARM 1 or ALARM 2. → Display shows the alarm time digits with the  or  indicators flashing.
2. Press **HR** ▷ repeatedly or hold down on the button to adjust the hours. Release **HR** ▷ when you reach the correct hour.
3. Press ◁ **MIN** repeatedly or hold down on the button to adjust the minutes. Release ◁ **MIN** when you reach the correct minute setting.
4. Turn the SET control back to RUN.
5. While the radio is switched off, select your choice of alarm mode by pressing ALARM 1-RADIO or ALARM 2-BUZZ. → Display shows  or .

SLEEP MODE

SETTING SLEEP

1. Press SLEEP/ RADIO ON to switch on the radio.
2. Within 1 second, press SLEEP/ RADIO ON again once or more until the display shows  and *5 L : 5 0*. While in the SLEEP display, press SLEEP/ RADIO ON once or more to select your sleep time. → Display shows in sequence:  and the sleep period time options: **SL:60**, **SL:30**, **SL:15** and **OFF**. → The sleep time and radio frequency appear briefly before showing standby clock time with the  indicator, if SLEEP is activated.

3. To cancel sleep, press either:

- ALARM RESET/ RADIO OFF
- REPEAT ALARM/ BRIGHTNESS CONTROL
- SLEEP/ RADIO ON once or more until  disappears from the display.

MAINTENANCE

- If you do not intend to use the set for a long time, withdraw the mains plug from the wall socket.
- Do not expose the set to humidity, rain, sand or excessive heat caused by heating equipment or direct sunlight.
- To clean the set, use a soft, slightly dampened chamois leather. Do not use any cleaning agents containing alcohol, ammonia, benzene or abrasives as these may harm the housing.

This warranty gives you specific legal rights. You may have other rights which vary from state/province to state/province.

Philips Service Solutions Group, P.O. Box 2976, Longview, Texas 75606, (903) 242-4800

EL6095T002 / MAC5433 / 1-97