

NET SAFETY

MONITORING INC.

MODEL: U1F, U2F & U4F-UV and UVC120

ULTRAVIOLET FIRE DETECTION SYSTEM

1, 2 and 4 Channel Field Mount Controller
with the UVC120 Detector

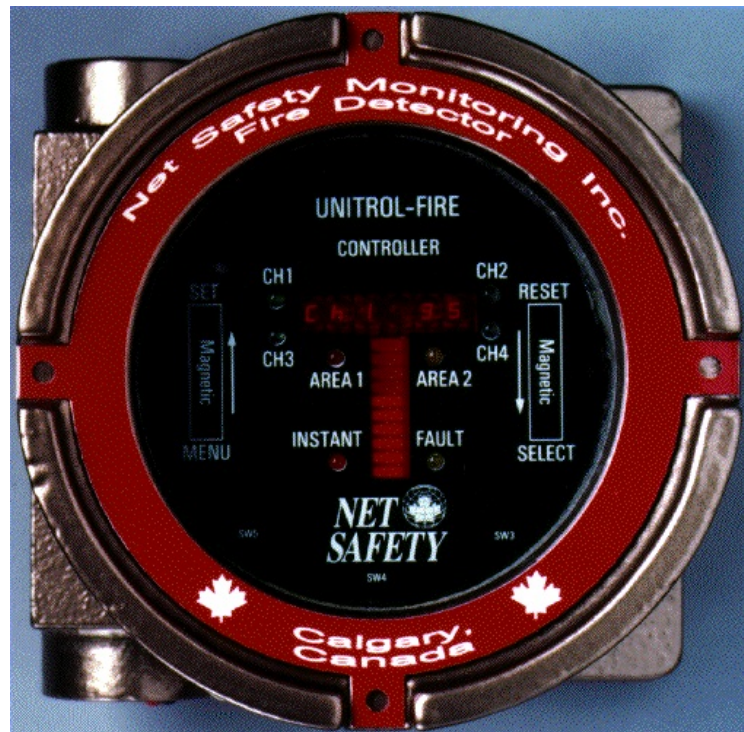

ISO 9001:2000



Part Number: MAN-0016-00 Rev. 2

Copyright © 2002 Net Safety Monitoring Inc.
Printed in Canada

This manual is provided for informational purposes only. Although the information contained in this manual is believed to be accurate, it could include technical inaccuracies or typographical errors. Changes are, therefore, periodically made to the information within this document and incorporated without notice into subsequent revisions of the manual. Net Safety Monitoring Inc. assumes no responsibility for any errors that may be contained within this manual.

This manual is a guide for the use of a 1, 2 and 4 Channel Field Mount Controller and the data and procedures contained within this document have been verified and are believed to be adequate for the intended use of the controller. If the controller or procedures are used for purposes other than as described in the manual without receiving prior confirmation of validity or suitability, Net Safety Monitoring Inc. does not guarantee the results and assumes no obligation or liability.

No part of this manual may be copied, disseminated or distributed without the express written consent of Net Safety Monitoring Inc.

Net Safety Monitoring Inc. products, are carefully designed and manufactured from high quality components and can be expected to provide many years of trouble free service. Each product is thoroughly tested, inspected and calibrated prior to shipment. Failures can occur which are beyond the control of the manufacturer. Failures can be minimized by adhering to the operating and maintenance instructions herein. Where the absolute greatest of reliability is required, redundancy should be designed into the system.

Net Safety Monitoring Inc., warrants its sensors and detectors against defective parts and workmanship for a period of 24 months from date of purchase and other electronic assemblies for 36 months from date of purchase.

No other warranties or liability, expressed or implied, will be honoured by Net Safety Monitoring Inc.

Contact Net Safety Monitoring Inc. or an authorized distributor for details.

Table of Contents

Unit I GENERAL INFORMATION	1
DESCRIPTION	1
FEATURES	1
CONTROLLER SPECIFICATIONS	1
<i>Figure 1 - Controller Dimensions</i>	2
DETECTOR SPECIFICATIONS	2
<i>Figure 2b - Swivel Mount Dimensions</i>	3
<i>Figure 2a - Detector Dimensions</i>	3
BASIC OPERATION - CONTROLLER	4
CONTROLLER FACEPLATE DESCRIPTION	4
<i>Figure 3 - Controller Face-Plate</i>	4
OUTPUTS	5
<i>Table 1 - Selectable Output Options</i>	5
<i>Figure 4 - Jumper Selection for Isolated or Non-Isolated Current Outputs</i>	5
PROGRAMMING OPTIONS	6
EXTERNAL RESET	6
AUTOMATIC DIAGNOSTICS AND FAULT IDENTIFICATION	6
VOTING LOGIC (not applicable to U1F)	7
DETECTOR	7
Unit II UV FIRE DETECTION	7
SYSTEM APPLICATION	7
DETECTOR SENSITIVITY	8
SPECTRAL SENSITIVITY RANGE	8
<i>Figure 5 - Various Spectral Distributions</i>	8
CONE OF VISION	9
<i>Figure 6 - Detector Cone of Vision</i>	9
SYSTEM SENSITIVITY	9
Unit III SYSTEM INSTALLATION	10
INSTALLATION	10
GENERAL WIRING REQUIREMENTS	10
CONTROLLER WIRING	10
<i>Figure 7a - Wiring for U1F-UV with Non-Isolated Current Output</i>	12
<i>Figure 7b - Wiring for U1F-UV with Isolated Current Output</i>	13
<i>Figure 8a - Wiring for U2F-UV with Non-Isolated Output</i>	14
<i>Figure 8b - Wiring Diagram for U2F-UV with Isolated Current Output</i>	15
<i>Figure 9a - Wiring for U4F-UV with Non-Isolated Current Output</i>	16
<i>Figure 9b - Wiring for U4F-UV with Isolated Current Output</i>	17
POSITION AND DENSITY OF DETECTORS	18
MOUNTING THE DETECTOR	18
<i>Figure 10 - Detector with Swivel Mount Assembly</i>	18
DIP SWITCH SETTINGS	18
<i>Figure 11b - Dip Switch</i>	19
<i>Figure 11a - Dip Switch Position</i>	19
CHANNEL SELECTION	19
CONTROLLER SENSITIVITY ADJUSTMENT	19
FIRE AREA VOTING SEQUENCE (not applicable to U1F)	20
RELAY OUTPUTS LATCHING/NON-LATCHING	20
RELAY OUTPUTS ENERGIZED/DE-ENERGIZED	20
TIME DELAY FOR AREA ALARMS	21
RELAY SETTINGS	21
<i>Figure 11c - Relay Position</i>	21
<i>Figure 11d - Relay Settings</i>	21

Unit IV SYSTEM OPERATION	22
STARTUP PROCEDURE	22
CHECKOUT PROCEDURE	22
MANUAL vi CHECK/COUNT TEST	22
MANUAL CHECK PROCEDURE	23
ALTERNATE TEST PROCEDURE	24
NORMAL OPERATION	24
FIRE RESPONSE	24
<i>Table 2 - Current Outputs</i>	25
AUTOMATIC DIAGNOSTICS AND FAULT IDENTIFICATION	25
<i>Table 3 - Error Codes</i>	26
MAIN MENU	26
BYPASS MODE (bPS)	27
SPECIAL FUNCTION MENU	27
FORCED CURRENT OUTPUT MODE (FoP)	27
CURRENT CALIBRATION MODE (CuC)	28
ADDRESS SET MODE (Adr Set) (Do not use)	28
Unit V MAINTENANCE	29
ROUTINE MAINTENANCE	29
TROUBLESHOOTING	29
DEVICE REPAIR AND RETURN	29
Appendix A Net Safety Monitoring Inc. Electrostatic Sensitive Device Handling Procedure	32
Appendix B Procedure For Activating Reed Switches	33
Appendix C Record Of Dip Switch Settings	34
Appendix D Common Ultra-Violet Absorbing Gases	35
Appendix E Wire Resistance In Ohms	36

Unit I GENERAL INFORMATION

DESCRIPTION

The UVC120 Flame Detectors combined with the U1F, U2F or U4F-UV Fire Controller provide fast, reliable flame detection in a wide variety of applications. The microprocessor based controllers simultaneously monitor up to four ultraviolet (UV) detectors to provide maximum operating flexibility at minimum expense. The Automatic Visual Integrity (vi) feature provides a continuous check of optical surfaces, sensitivity and electronic circuitry of the detector/controller system. Automatic fault identification monitors system operation and provides a digital display of system status using a numerical code. Controller response includes actuation of relays for direct control of field response devices and a full array of faceplate indicators. Other features include individual channel and area identification, "voting" capability and manual vi testing.

FEATURES

- ▶ Non-Intrusive testing activated by magnets
- ▶ Instantaneous response to ultraviolet radiation
- ▶ Automatic and manual Visual Integrity (vi) testing
- ▶ Adjustable sensitivity and time delay
- ▶ All automatic test functions performed with the system on line
- ▶ Automatic fault identification
- ▶ Individual channel identification with voting options
- ▶ Latching Area LEDs identify the area responding to fire
- ▶ Microprocessor-based controller is easily field-programmable.
- ▶ Two digital displays, one bar graph display and high intensity LEDs indicate system status information
- ▶ Relay outputs are field adjustable as latching or non-latching
- ▶ Alarm relays are programmable for normally energized or de-energized operation
- ▶ Individual detector output (count rate) can be visually monitored on the digital display
- ▶ Two 4-20mA current outputs (U2F and U4F). One 4-20mA output on U1F
- ▶ Conduit seals recommended to prevent moisture damage but not required

CONTROLLER SPECIFICATIONS

- ▶ **Operating Voltage:**
24 Volts DC nominal. 18 to 32Vdc.
- ▶ **Power Consumption (controller only):**
2.4 watts nominal, 4.4 watts maximum.
100 mA nominal, 180 mA maximum at 24 Volts DC.

Maximum startup current is 1.5 Amperes for 10 milliseconds. Power supplies with fold back current limiting are not recommended.
- ▶ **Maximum Ripple:**
Ripple should not exceed 5 Volts peak-to-peak. The sum of DC plus ripple must be ≥ 18 Vdc and ≤ 32 Vdc
- ▶ **Temperature Range:**
Operating: -40°C to +85°C (-40°F to +185°F)
Storage: -55°C to +150°C (-65°F to +302°F)

- ▶ **Relay Contacts:**
Normally open/normally closed contacts rated for 5 Amperes at 30 Volts DC/ 250 Volts AC
- ▶ **Current Outputs:**
4-20mA DC into a maximum external loop resistance of 600 Ohms at 18-32 Volts DC
- ▶ **Dimensions:**
Refer to *Figure 1*
- ▶ **Shipping Weight (approximate):**
2 lbs (0.9 kilograms)
- ▶ **Certification:**
CSA, NRTL/C, NEMA 4X certified for hazardous locations
Class 1, Division 1, Groups B, C and D
IEC approval (Class 1, Zone 1 Groups IIB+H2 T5)
- ▶ **System Sensitivity:**
Sensitivity for the standard controller is field adjustable over a range of 8 through 120 counts per second (cps) in increments of 8 cps. The maximum response distance is achieved at an 8 cps sensitivity setting. For applications involving high background radiation potential, the system can be de-sensitized by increasing the count rate required to actuate alarms. The 120 cps setting is the lowest sensitivity.
- ▶ **Response Time:**
Response to a saturating (high intensity) UV source is typically 10 milliseconds for the instant alarm outputs and 0.5 seconds for the area alarm outputs when sensitivity is set for 8 cps and time delay is set for 0.5 seconds (minimum settings).

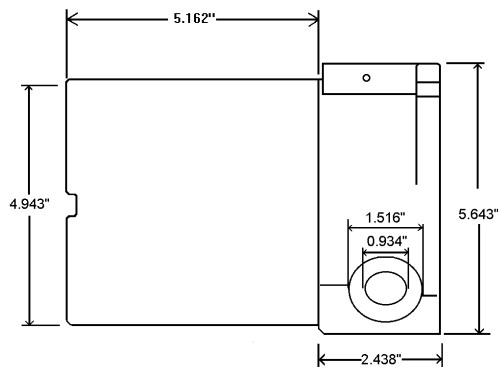

Figure 1 - Controller Dimensions

DETECTOR SPECIFICATIONS

- ▶ **Operating Voltage:**
290Vdc \pm 3Vdc (provided for controller)

- ▶ **Power Consumption (each detector):**
0.29 Watts nominal, 0.5 Watts maximum
1 mA nominal, 1.7 mA maximum
- ▶ **Temperature Range:**
Operating: -40°C to +125°C (-40°F to +257°F)
Storage: -55°C to +150°C (-65°F to +302°F)
- ▶ **Dimensions:**
Refer to *Figures 2a and 2b*
- ▶ **Detector Enclosure Materials:**
Available in anodized copper-free aluminum or optional stainless steel
- ▶ **Shipping Weight (approximate):**
2 lbs (0.9 kilograms)
- ▶ **Certification:**
CSA, NRTL/C, NEMA 4X certified for hazardous locations
Class 1, Division 1, Groups B, C and D
IEC approval (Class 1, Zone 1 Groups IIB+H2 T5)
- ▶ **Spectral Sensitivity Range:**
The detector responds to UV radiation over the range of 185 to 260 nanometres
(1850 to 2600 angstroms)
- ▶ **Cone of Vision:**
The Detector has a nominal 120 degree cone of vision

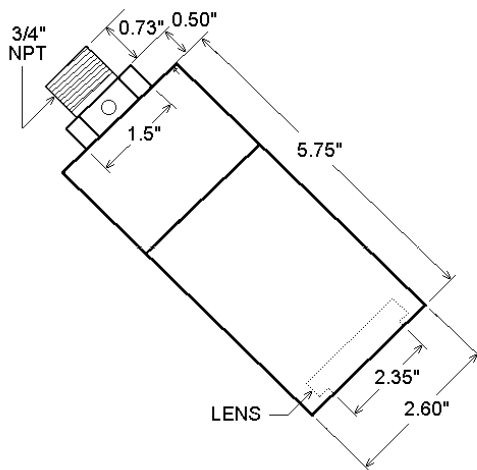

Figure 2a - Detector Dimensions

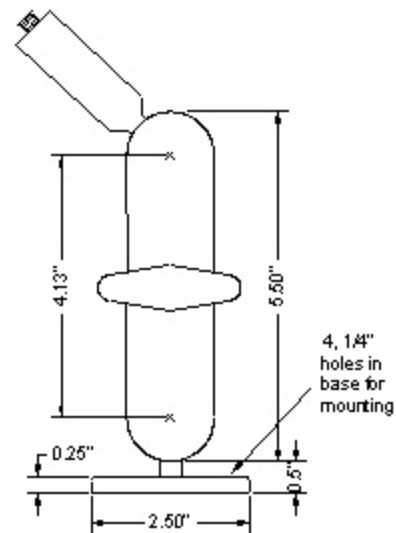

Figure 2b - Swivel Mount Dimensions

BASIC OPERATION - CONTROLLER

CONTROLLER FACEPLATE DESCRIPTION

The controller faceplate provides LEDs and two digital displays for identifying status conditions, a bar graph display for indicating an alarm condition and **MENU/SET** and **SELECT/RESET** push-button switches (See appendix for instructions on activation) for testing and resetting the system. Refer to Figure 3.

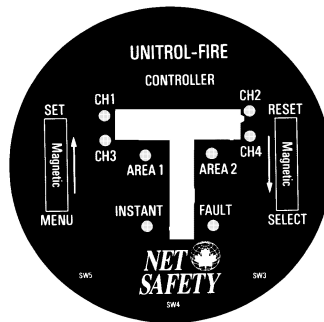

Figure 3 - Controller Face-Plate

- ▶ **Digital Displays** - The left side of the digital display is normally off. If a fire alarm or visual integrity fault is detected, it indicates the channel number of the alarm or fault. The digital displays indicate system status including system error codes, visual integrity (**vi**) faults, system faults or fire alarms. The right side of the display shows 'nor' in normal operating mode. If more than one channel is in an alarm or fault condition the digital displays will cycle through these channels. Since at least one side of the display is always lit they also function as a power indicator.
- ▶ **Bar Graph Display** - Normally off. Flashing when fire detected in any area.
- ▶ **Instant LED** - (no time delay) Flashes when any detector signal exceeds the fire sensitivity setting.
- ▶ **Area 1 & 2 LEDs** - (Area 1 only for U1F) If the selected "voting" criteria of the area and the preset time delay has elapsed the corresponding LED starts flashing.
- ▶ **Fault LED** - flashes upon detection of an overall system fault or **vi** fault.
- ▶ **Channel LEDs** - (1, 2 or 4 depending on model) flash to indicate detector in alarm and remain illuminated until reset after an alarm condition has returned to normal.
- ▶ **MENU/SET Reed Switch** - is used to enter the main menu, to toggle through menu selections and in conjunction with the **SELECT/RESET** Reed Switch to enter the special functions menu.
- ▶ **SELECT/RESET Reed Switch** - is used for a basic system reset, menu selection and with the **MENU/SET** Reed Switch to enter the special functions menu. This switch is also used during the manual **vi** test.

OUTPUTS

Relay Outputs:

The Instant, Area and Fault relays have SPDT contacts rated 5 Amps at 30 Volts DC or 250 Volts AC.

The Instant and Area alarm relays are programmable for either normally energized or normally de-energized operation and for latching or non-latching (programmable as a group not individually). The fault relay is only normally energized. The relays can be configured with jumpers for normally open or normally closed contacts.

RECOMMENDATION

The fault relay output should not be used to activate an automatic shutdown procedure.

The fault output indicates a potential problem with the controller, not an alarm condition.

Refer to Table 1 for a summary of the relay programming options.

OUTPUT	Selectable Normally Open/Closed	Selectable Normally Energized/De-Energized	Selectable Latching/Non-Latching
AREA ¹	Y	Y	Y
INSTANT	Y	Y	Y
FAULT	Y	N ²	N ³

Table 1 - Selectable Output Options

¹ Area alarms are programmed together, not individually.

² Fault relay is normally energized.

³ Fault relay is non-latching.

Current Outputs:

4-20 mA DC current outputs transmit system information to other devices. The current outputs can be wired for isolated or non-isolated operation by changing the jumpers as shown in Figure 4. Refer to Unit IV, System Operation for a description of the current output signal levels.

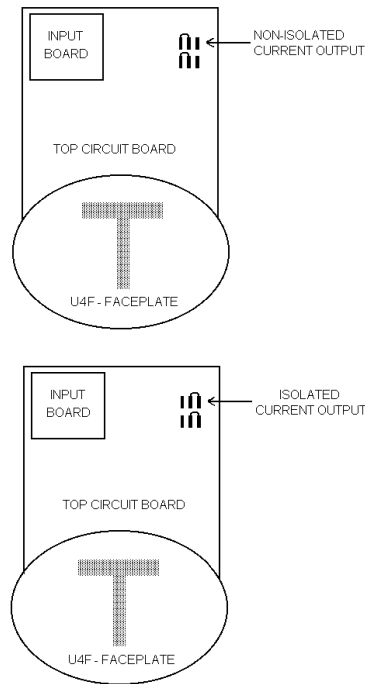

Figure 4 - Jumper Selection for Isolated or Non-Isolated Current Outputs

PROGRAMMING OPTIONS

DIP switches located on the circuit board are used to “program” various options including:

- ▶ channel selection,
- ▶ system sensitivity,
- ▶ fire area voting logic,
- ▶ time delay for fire area alarms,
- ▶ relay latching/non-latching selection, and
- ▶ relay energized/de-energized selection.

NOTE

Power to the controller must be cycled to make dip switch changes take effect.

EXTERNAL RESET

A normally open, momentary closure switch connected between the external reset terminal and the negative power terminal provides remote reset.

AUTOMATIC DIAGNOSTICS AND FAULT IDENTIFICATION

The microprocessor-based controller features self-testing circuitry that continuously checks for problems that could prevent proper system response. When power is applied, the microprocessor automatically tests memory. In the Normal Operating Mode it continuously monitors the system to ensure proper functioning. A “watchdog” timer is maintained to ensure that the program is running correctly.

The main loop of the operating program continuously cycles through the Automatic Visual Integrity test, checking each detector and its wiring. The microprocessor can be interrupted by

(Automatic Diagnostics and Fault Identification Cont)

any one of several status changes such as a fault or a "fire" signal from one of the detection areas to take appropriate action.

If a system or vi fault is detected the Fault LED flashes, digital displays and current outputs identify the nature of the fault and the fault relay is de-energized.

VOTING LOGIC (not applicable to U1F)

The controller can be DIP switch configured for either one or two monitoring areas. For a one area configuration, all channels are considered as being in Area 1 and both Area alarm relays will be activated together.

The dip switches can be set so that only one channel need be in alarm to activate the area alarm or any two channels must 'vote' (see a fire at the same time) to activate the area alarm. The instant alarm will be activated when any channel sees UV radiation exceeding the preset sensitivity setting, no matter what voting option is being used.

For a two area configuration, channel one (one and two for U4F) make up Area 1 and channel three (three and four for U4F) make up Area 2. With the U4F each Area alarm may be programmed with different voting criteria (ie. Area 1 may be set so that either channel one OR channel two may activate the area alarm, and Area 2 may be set so that both channels three AND four must see the fire at the same time to activate the Area alarm).

DETECTOR

The detector responds to UV radiation over the range of 185 to 260 nanometers. It is not sensitive to direct or reflected sunlight nor to normal artificial lighting.

The detector is housed in an explosion-proof enclosure that is designed to meet most national and international standards. It is available in anodized aluminum or optional stainless steel.

The detector is typically mounted with a swivel mounting assembly which is recommended. Other mounting arrangements are possible.

Unit II UV FIRE DETECTION

SYSTEM APPLICATION

The detector responds instantly to ultraviolet radiation emitted by a flame. It is designed for use in hazardous locations and is suitable for use in outdoor applications.

Typical applications for UV detection systems are:

- ▶ *around highly combustible materials*
- ▶ *if instantaneous response to flame is needed*
- ▶ *where automated fire protection is required*
- ▶ *to protect large capital investments*

Petroleum Products Handling

- ▶ *petroleum loading terminals*
- ▶ *offshore platforms*
- ▶ *pipeline stations*
- ▶ *tank farms*

- ▶ refineries
- ▶ engine rooms

Gaseous Fuel Handling

- ▶ butane and propane loading and storage
- ▶ pipeline compressor stations
- ▶ gas gathering facilities
- ▶ LNG loading, transfer and storage
- ▶ hydrogen
- ▶ gas turbines

Other Processes

- ▶ paint spray booths
- ▶ chemical and petrochemical production
- ▶ powder coating booths

Automated fire protection systems also have applications in any manufacturing or research facility where the potential of fire may be low to moderate but the losses due to a fire would be high.

DETECTOR SENSITIVITY

SPECTRAL SENSITIVITY RANGE

The UV fire detector responds to radiation wavelengths of 185 to 260 nanometres (1850 to 2600 angstroms). Figure 5 illustrates the range of sensitivity and compares this range to other forms of radiation. Note that UV radiation reaching the earth from the sun does not extend into the sensitivity range of the detector. Nor does radiation from normal artificial lighting, such as fluorescent, mercury vapor and incandescent lamps.

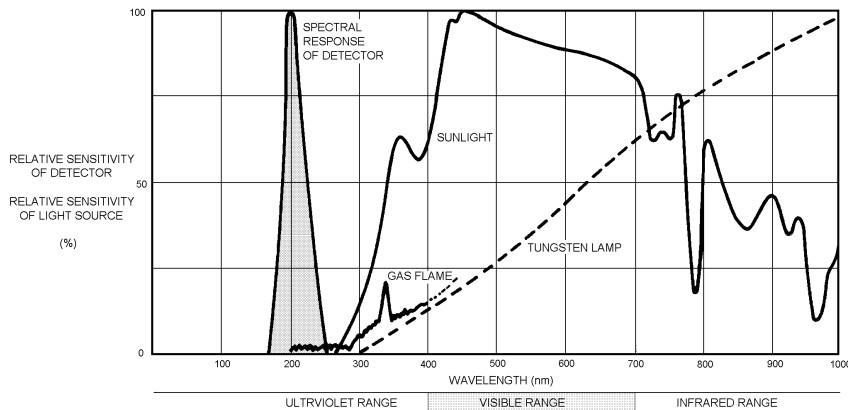

Figure 5 - Various Spectral Distributions

NOTE

Some mercury vapor lamps can operate for extended periods with cracked or damaged envelopes and will then emit UV radiation in the range of the detector. Remove defective mercury vapor lamps from service.

The UV sensor responds to radiation other than ultraviolet. X-rays can activate the detector and are often used in industrial inspection. It may be necessary to disable the system if X-ray inspection is conducted nearby.

UV radiation other than that produced by an actual fire is referred to as "background UV." An example of a high level of background UV could be the case of a flare stack situated outside of a building. The UV radiation produced by this flare may be detected when a door to the building is opened. Windows or reflective surfaces may also result in unusually high levels of UV radiation entering the building from the flare. In a situation like this, the fire detection system response must be carefully checked and the sensitivity level adjusted high enough so that this "background" UV will not cause false alarms.

Caution must be exercised if the detection system is turned off, since the hazardous area will not be protected.

NOTE

Ultraviolet detectors are sensitive to arc welding and if this type of radiation can be expected, nuisance alarms must be controlled through proper application including careful positioning and shielding of the detectors. Some applications may require a UV/IR system.

CONE OF VISION

The fire detector has a nominal 120 degree cone of vision. Figure 6 shows the cone of vision and detector response to a UV source at various distances. The practical application distance is up to about 50 feet (15 meters). The distance is directly related to the intensity of the ultraviolet radiation source. Programming the controller to require a high count rate results in low system sensitivity. Consider that UV absorbing chemical vapors may be present. (See Appendix D)

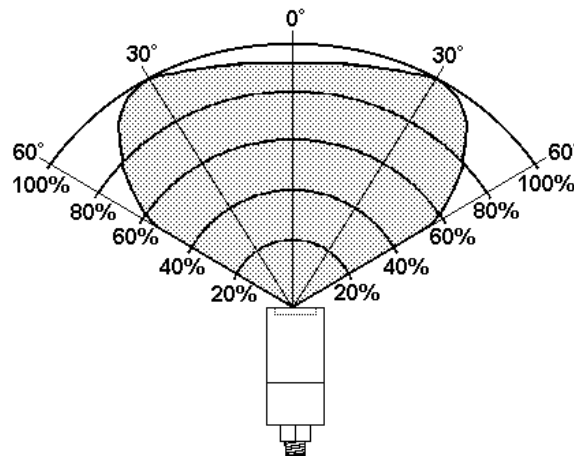

Figure 6 - Detector Cone of Vision

SYSTEM SENSITIVITY

The UV tube count rate generated by different fires at the same distance is unpredictable. Generally, if a fire doubles in size the tube response is increased by about 60 percent.

Controller sensitivity and time delay settings for various applications is dependent on the severity of the hazard and the action required if a fire occurs. The system can be adjusted to various

sensitivity levels by programming the controller to respond at a pre-determined detector count rate which is dependent upon the intensity of the ultraviolet radiation reaching the detector, which in turn depends on the type of fuel, temperature, flame size, distance from the detector and concentration of UV absorbing vapors present.

Programming the controller to respond to a low count rate results in high system sensitivity.

Unit III SYSTEM INSTALLATION

INSTALLATION

GENERAL WIRING REQUIREMENTS

NOTE

The wiring procedures in this manual are intended to ensure proper functioning of the device under normal conditions. However, because of the many variations in wiring codes and regulations, total compliance to these ordinances cannot be guaranteed. Be certain that all wiring complies with applicable regulations that relate to the installation of electrical equipment in a hazardous area. If in doubt, consult a qualified official before wiring the system.

Shielded cable is highly recommended for power input and signal wires to protect against interference caused by extraneous electrical 'noise'. Relay outputs do not require shielded cable. Recommended detector cable is four conductor, shielded cable, 18 AWG, rated 300V. If the wiring cable is installed in conduit, the conduit must not be used for wiring to other electrical equipment. Detectors can be located up to 2000 feet (600 metres) from the controller.

Water will damage electronic devices. Moisture in the air can condense within electrical conduit and drain into the enclosure, therefore, water-proof and explosion-proof conduit seals are recommended to prevent water accumulation within the enclosure. Seals should be located as close to the device as possible and not more than 18 inches (46 cm) away. Explosion-proof installations may require an additional seal where conduit enters a non-hazardous area. Conform to local wiring codes.

When pouring a seal, use a fibre dam to assure proper formation of the seal. The seals should never be poured at temperatures below freezing.

The jacket and shielding of the cable should be stripped back to permit the seal to form around the individual wires. This will prevent air, gas and water leakage through the inside of the shield and into the enclosure.

It is recommended that explosion-proof drains and conduit breathers be used. In some applications, alternate changes in temperature and barometric pressure can cause 'breathing' which allows moist air to enter and circulate inside the conduit. Joints in the conduit system are seldom tight enough to prevent this 'breathing'.

CONTROLLER WIRING

NOTE

The controller contains semiconductor devices that are susceptible to damage by electrostatic discharge. An electrostatic charge can build up on the skin and discharge when an object is touched. Therefore, use caution when handling, taking care not to touch the terminals or electronic components. For more information on proper handling, refer to the Appendix.

The controller can be configured for isolated or non-isolated current outputs by changing jumpers on circuit board as per Figure 4. Figures 7a, 8a and 9a show the wiring for isolated current outputs and Figures 7b, 8b and 9b show wiring for non-isolated current outputs.

U1F CONTROLLER NON-ISOLATED CURRENT OUTPUT

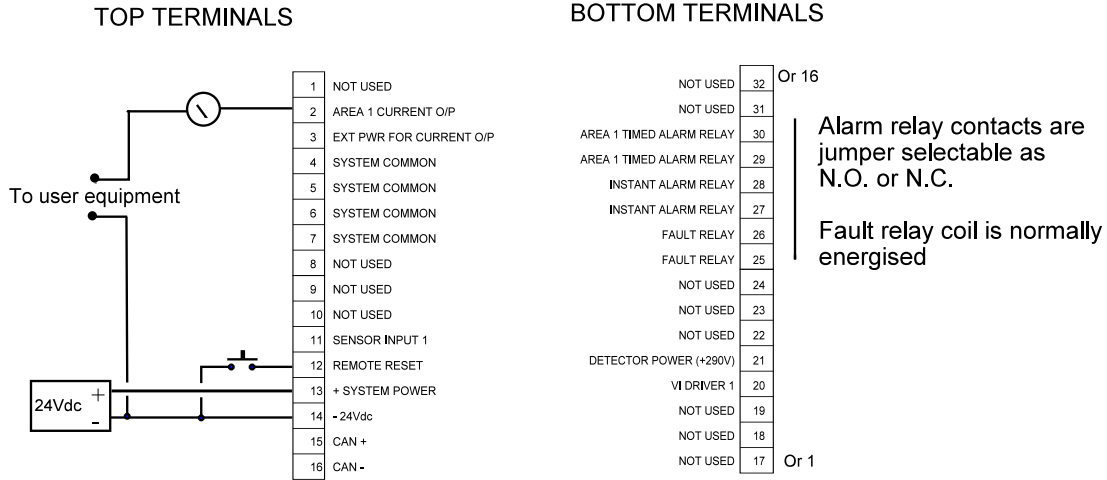

Note: Terminals shown as 17 thru 32 above may be labeled 1 thru 16 on unit

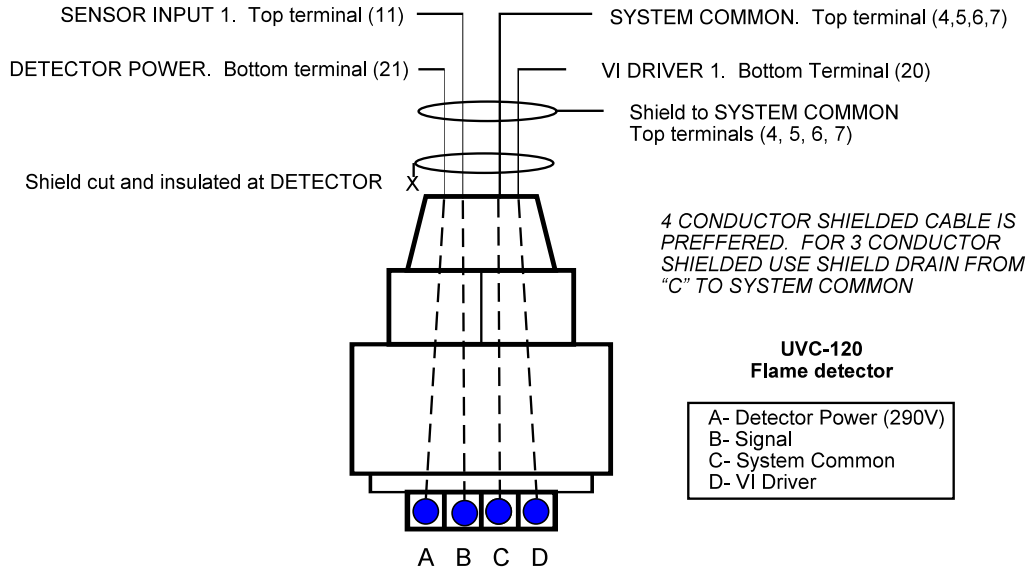
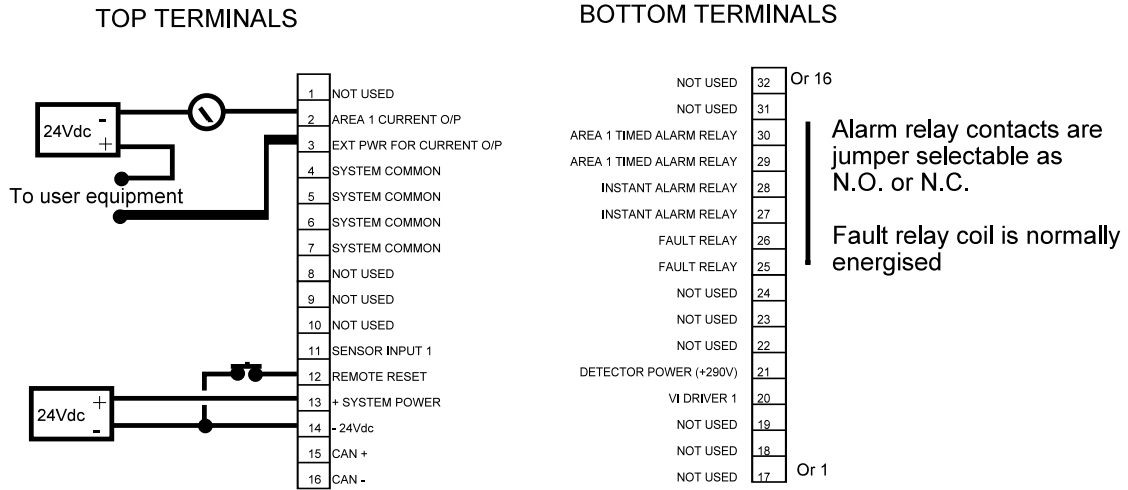

Figure 7a - Wiring for U1F-UV with Non-Isolated Current Output

U1F-UV CONTROLLER ISOLATED CURRENT OUTPUT



Note: Terminals shown as 17 thru 32 above may be labeled 1 thru 16 on unit

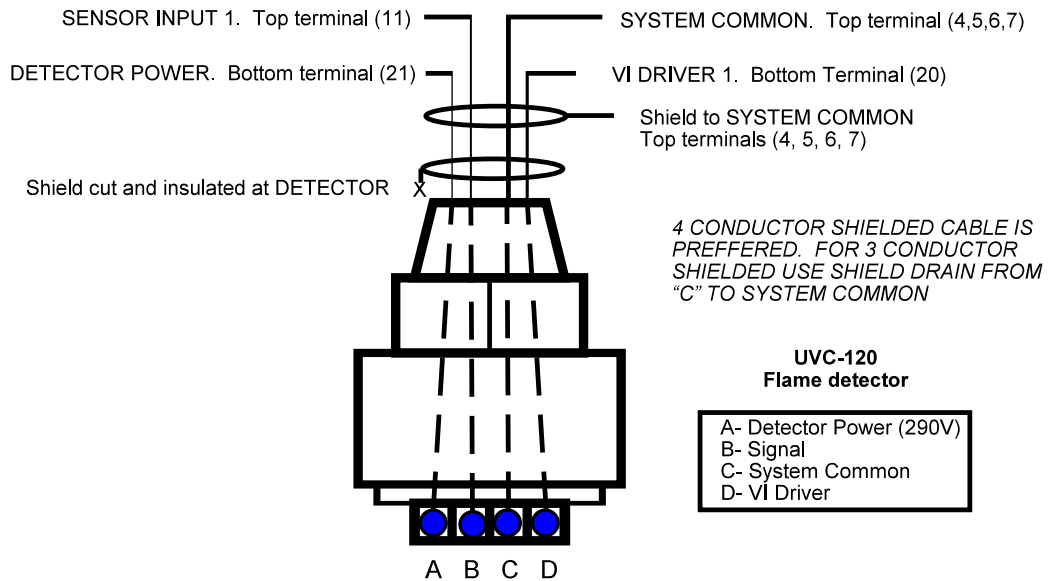
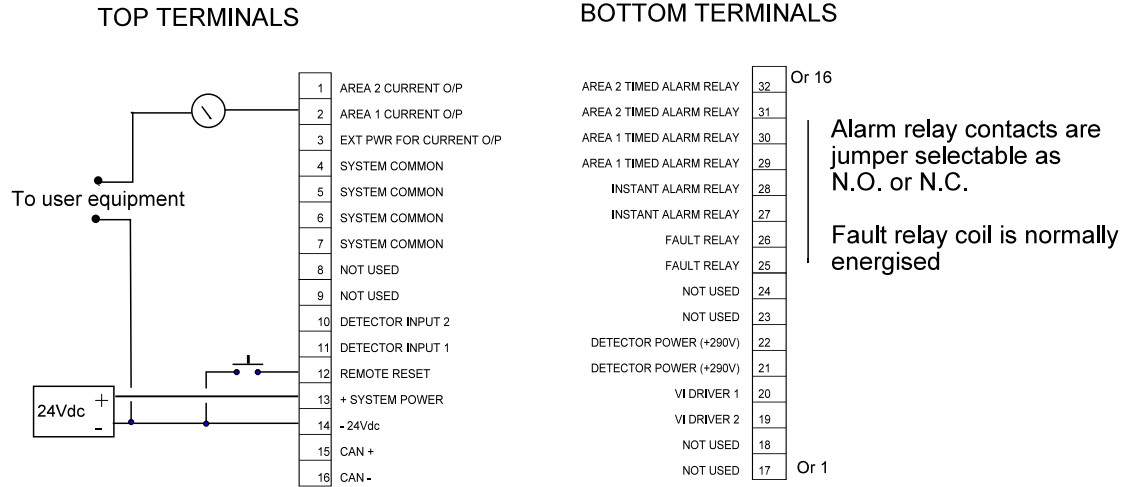

Figure 7b - Wiring for U1F-UV with Isolated Current Output

U2F CONTROLLER NON-ISOLATED CURRENT OUTPUT



Note: Terminals shown as 17 thru 32 above may be labeled 1 thru 16 on unit

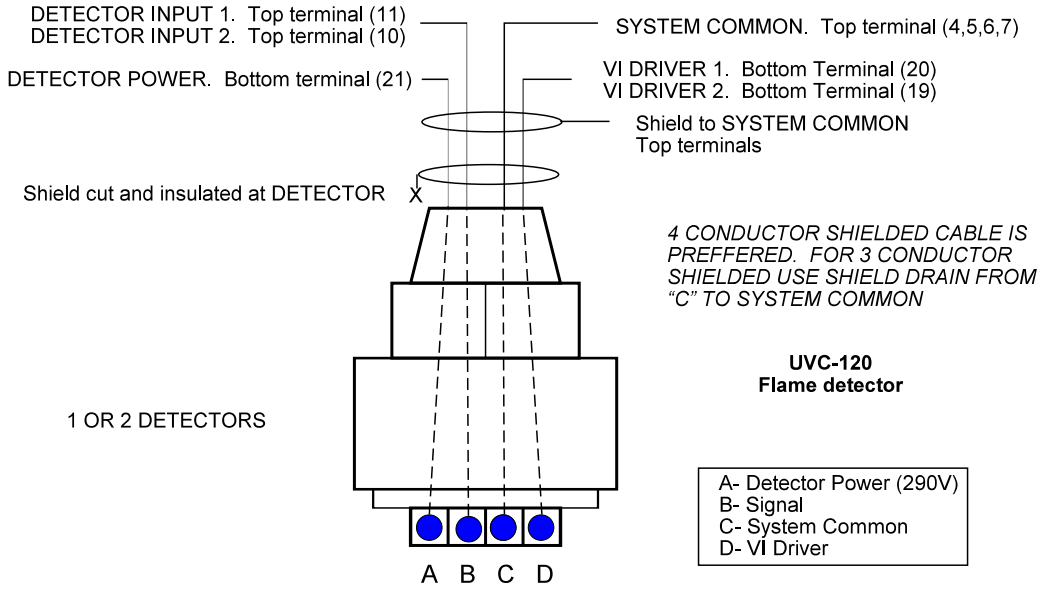
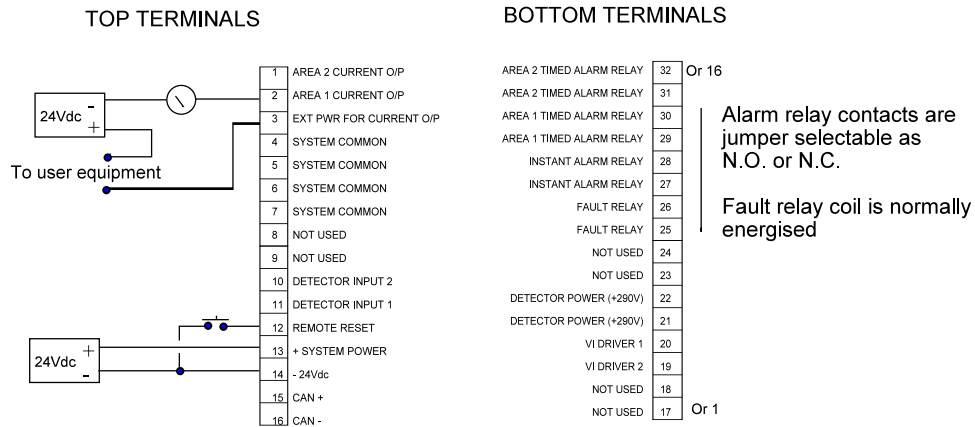

Figure 8a - Wiring for U2F-UV with Non-Isolated Output

U2F-UV CONTROLLER ISOLATED CURRENT OUTPUT



Note: Terminals shown as 17 thru 32 above may be labeled 1 thru 16 on unit

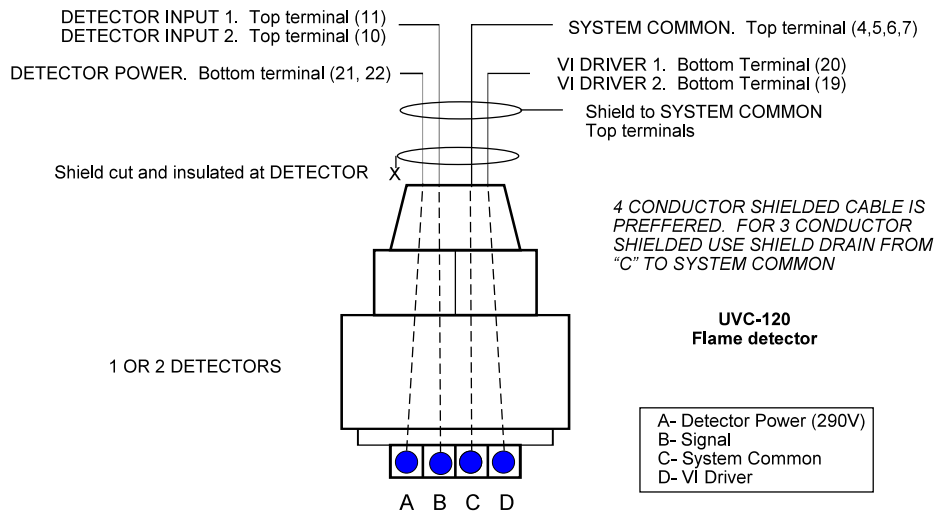
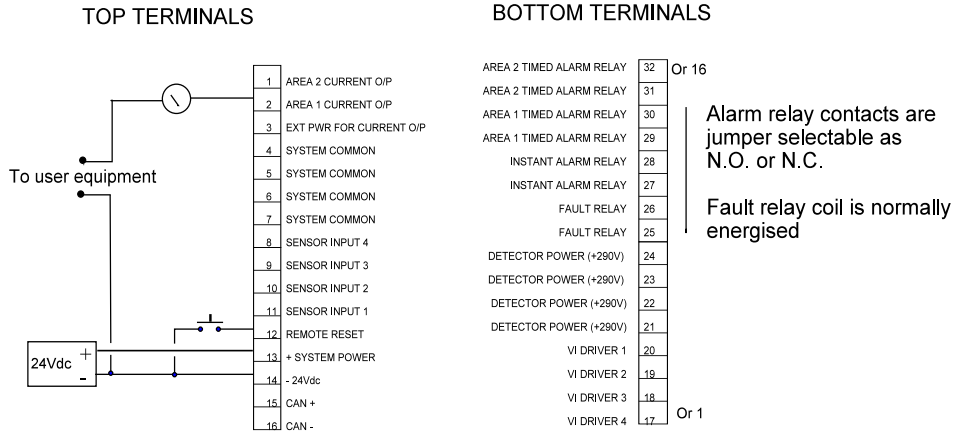

Figure 8b - Wiring Diagram for U2F-UV with Isolated Current Output

U4F CONTROLLER NON-ISOLATED CURRENT OUTPUT



Note: Terminals shown as 17 thru 32 above may be labeled 1 thru 16 on unit

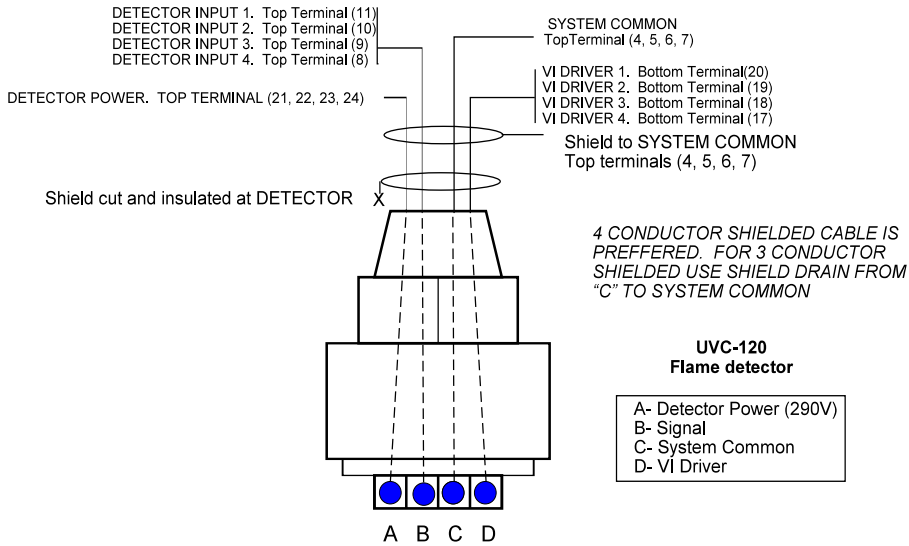
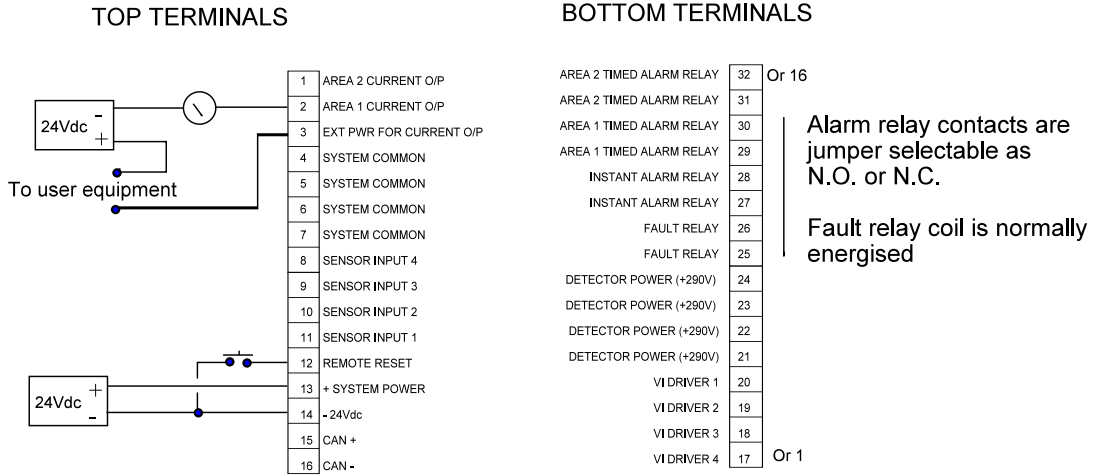

Figure 9a - Wiring for U4F-UV with Non-Isolated Current Output

U4F-UV CONTROLLER ISOLATED CURRENT OUTPUT



Note: Terminals shown as 17 thru 32 above may be labeled 1 thru 16 on unit

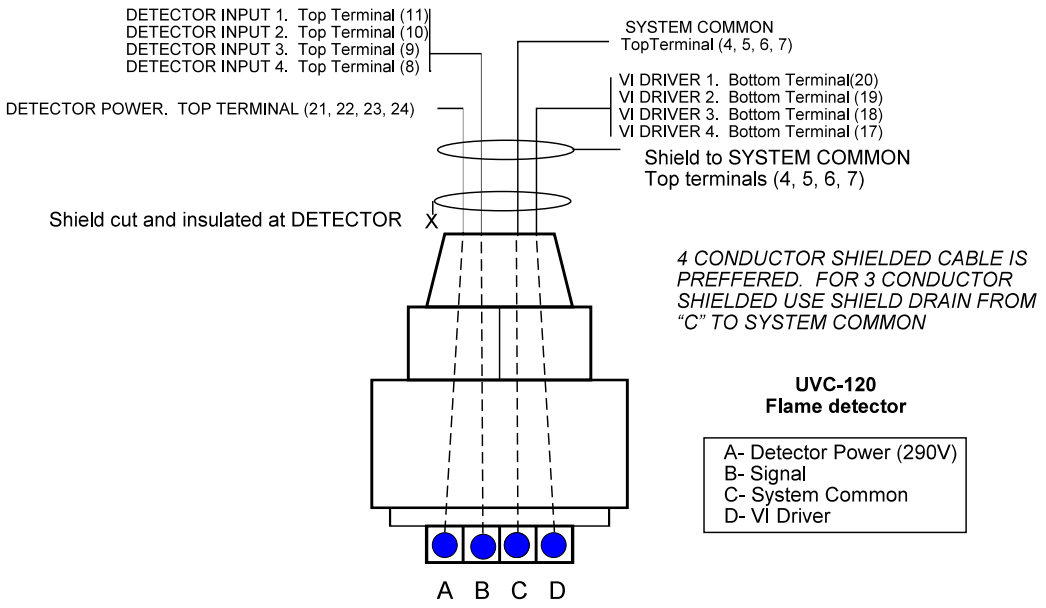

Figure 9b - Wiring for U4F-UV with Isolated Current Output

POSITION AND DENSITY OF DETECTORS

The detector has a nominal 120° cone of vision. In an application such as a loading rack with a ceiling height of 25 feet (7.5 meters) where it is desired to have complete detector coverage at floor level and a detector is mounted 2 feet (0.6 meter) from the ceiling and pointed straight down, the distance from the detector to the designated level would be 23 feet (7 meters) and because of its 120° cone of vision the detector would cover a circular area 80 feet (24 meters) in diameter at floor level. A sketch of the area to be covered will indicate the number of detectors required to monitor the area. Detectors should be placed as close as practical to the expected fire hazard.

NOTE

Do not mount UV detectors close to the ceiling of enclosed buildings if smoke might accumulate before the break-out of flame. It is preferable to mount the detectors on walls a few feet (or about 1 meter) below the ceiling where they may respond before being obscured by smoke. Consider shortening time delay settings when smoke is expected to accumulate during a fire. If dense smoke is likely to accumulate prior to flame (as in an electrical fire), supplement UV detectors with other protection.

MOUNTING THE DETECTOR

Locate detectors to ensure an unobstructed view of the area to be monitored and where accessible for cleaning the detector window and *vi* reflecting surface. Take care so dirt will not accumulate and obscure the detector viewing window. Detectors mounted outdoors should be pointed downward to prevent the cone of vision from scanning the horizon where long duration lightning flashes or far-off arc welding may activate the detector. To minimize dirt accumulation around the *vi* surfaces, mount the detectors so that the internal *vi* tube is on top. The silver external reflector should be placed directly over the *vi* tube. Refer to Figures 2a and 2b for the detector and swivel mounting assembly dimensions. Refer to Figure 10 for a diagram of the assembled detector and swivel assembly.

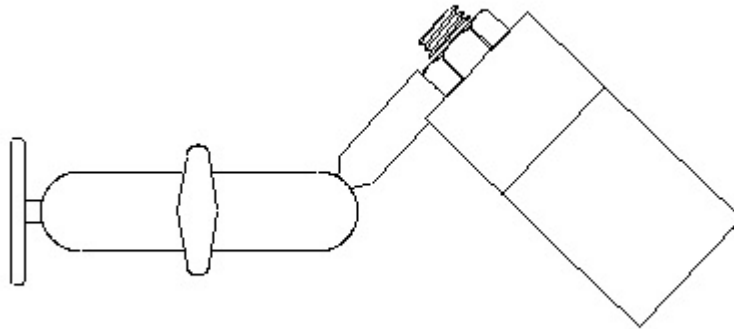

Figure 10 - Detector with Swivel Mount Assembly

DIP SWITCH SETTINGS

NOTE

To make DIP switch changes take effect, cycle controller power off then on.

The DIP switches on the controller circuit board must be properly programmed before applying power to the system. There are three banks of 8 position DIP switches which are OFF or ON to select area and detector combinations, controller sensitivity, fire voting logic, output latching and

time delay. See Figure 11a below. The switch banks are numbered from top to bottom as SW 5, SW 4 and SW 3.

Individual ON/OFF switches are designated "SW X.Y where 'X' refers to the switch bank and 'Y' refers to the switch number on 'X' bank. See Figure 11b.

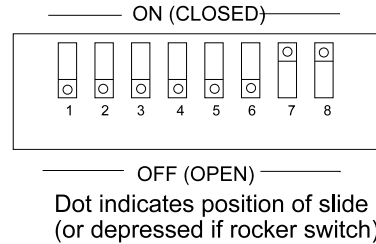
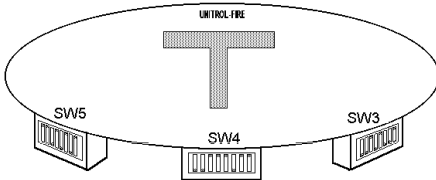

Figure 11a - Dip Switch Position

Figure 11b - Dip Switch

CHANNEL SELECTION

Switches SW 3.1 through SW 3.4 enable the detectors that are to be connected to the controller. The appropriate switch must be set to the 'OFF' position to enable each detector connected. If a switch is off but no detector is connected in that location the controller will indicate a fault. If a switch is on, but a detector is connected, the controller will appear to be operating correctly but that detector will be eliminated from the Automatic vi test sequence and any faults occurring in its circuit will not be annunciated.

U1F, U2F and U4F

- ▶ SW 3.1: OFF: detector 1 connected
ON: detector 1 not connected

U2F and U4F

- ▶ SW 3.2: OFF: detector 2 connected
ON: detector 2 not connected

U4F only

- ▶ SW 3.3: OFF: detector 3 connected
ON: detector 3 not connected
- ▶ SW 3.4: OFF: detector 4 connected
ON: detector 4 not connected

CONTROLLER SENSITIVITY ADJUSTMENT

Switches SW 4.1 through SW 4.4 set controller sensitivity in 8 cps (counts per second) increments.

- ▶ SW 4.1 ON: 8 cps
- ▶ SW 4.2 ON: 16 cps
- ▶ SW 4.3 ON: 32 cps
- ▶ SW 4.4 ON: 64 cps

The switch values are added together. These switches are factory set to a sensitivity of 24 counts per second, as shown in the example.

Example: SW 4.1 ON
SW 4.2 ON sensitivity
SW 4.3 OFF = 24 cps
SW 4.4 OFF

FIRE AREA VOTING SEQUENCE (not applicable to U1F)

SW 4.5, SW 4.6 and SW 4.8 select voting sequence which can be Fire Area 1 only (all detectors in one area) or Fire Area 1 separate from Fire Area 2. When separate, Fire Area 1 consists of detector 1 (1 and 2 for U4F) and Fire Area 2 consists of detector 2 (detector 3 and 4 for U4F). Switch SW 4.7 should be placed in the 'OFF' position at all times.

Fire Area 1 Separate from Fire Area 2:

- ▶ SW 4.7 OFF
- ▶ SW 4.8 ON
- ▶ SW 4.5 programs Fire Area 1 (detector 1 for U2F) (detectors 1 and 2 for U4F)
 - OFF: votes one of two detectors (always OFF for U2F)
 - ON: votes two of two detectors
- ▶ SW 4.6 programs Fire Area 2 (detector 3 for U2F) (detectors 3 and 4 for U4F)
 - OFF: votes one of two detectors (always OFF for U2F)
 - ON: votes two of two detectors

Fire Area 1 only:

- ▶ SW 4.8 OFF
- ▶ SW 4.7 OFF
- ▶ SW 4.6 OFF
- ▶ SW 4.5 OFF: votes any one of all detectors
ON: votes any two of all detectors

RELAY OUTPUTS LATCHING/NON-LATCHING

The alarm relays are programmed together for latching or non-latching operation (the fault relay is only non-latching).

- ▶ 5.1: ON: non-latching operation
OFF: latching operation

NOTE

Latched outputs are unlatched by activating the **RESET** switch.

RELAY OUTPUTS ENERGIZED/DE-ENERGIZED

The area and instant alarm relays can be programmed for normally energized or normally de-energized operation using SW 5.2 . The fault relay is always normally energized. SW 5.2 is factory set to de-energized operation (ON)

- ▶ SW 5.2: OFF: *normally energized operation*
ON: *normally de-energized operation*

TIME DELAY FOR AREA ALARMS

NOTE

Time delay affects the Area alarms only; the instant alarm operates as soon as a flame is detected.

The time delay for the Area alarms is set using SW 5.3 to SW 5.7. If all of the switches are placed in the 'OFF' position the time delay will be 0.5 seconds (minimum setting).

- ▶ SW 5.3-7: OFF: 0.5 sec. time delay
- ▶ SW 5.3: ON: 0.5 sec. time delay
- ▶ SW 5.4: ON: 1 sec. time delay
- ▶ SW 5.5: ON: 2 sec. time delay
- ▶ SW 5.6: ON: 4 sec. time delay
- ▶ SW 5.7: ON: 8 sec. time delay

If switch 5.8 is "OFF" then in Bypass mode:

- the current output is 4 mA
- the Fault Relay state remains unchanged (if it was energized, it remains energized; if it was de-energized, it remains de-energized)

If switch 5.8 is "ON" then in Bypass mode:

- the current output is 3 mA
- the Fault Relay is de-energized

The total time delay is the added value of the switches turned ON. Switches can be turned ON in any combination for a time delay from 0.5 to 15.5 seconds in half second increments. These switches are factory set to a 3.0 second time delay as shown in the example below.

Example: SW 5.3 OFF time delay
SW 5.4 ON = 2.5 sec.
SW 5.5 ON
SW 5.6 OFF
SW 5.7 OFF

NOTE

SW 3.5 through SW 3.8 are not used.

RELAY SETTINGS

There are four relays on the controller circuit board that can be configured for normally OFF or normally ON operation by moving the jumpers which are located below the relays. See Figure 11c for the location of the relays on the circuit board and Figure 11d for the settings.

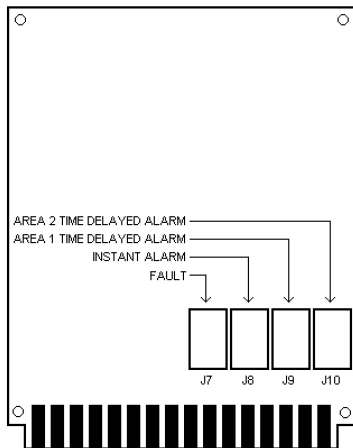

Figure 11c - Relay Position

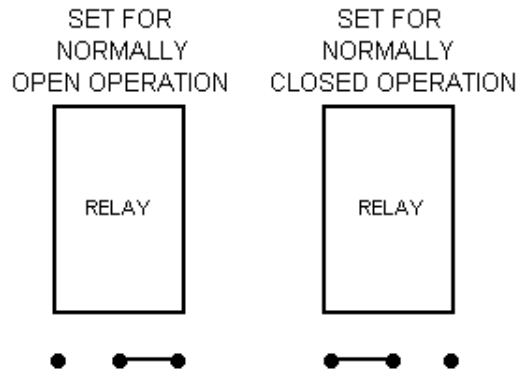

Figure 11d - Relay Settings

Unit IV SYSTEM OPERATION

STARTUP PROCEDURE

CAUTION

Placing the controller in the Bypass mode inhibits its outputs, preventing actuation of any extinguishing or alarm circuits that are connected. For maximum safety, however, secure output loads (remove power from any devices that would normally be actuated by the system) before manually testing the system. Remember to place this same equipment back into service when the test is complete.

1. After setting the DIP switches and making all electrical connections, apply power to the controller.
2. Perform the Checkout Procedure.
3. If the controller appears to be operating normally (performs power-up countdown and then shows 'Nor' on the display), remove mechanical blocking devices and restore power to the extinguishing loads.

NOTE

Be sure that the detector is correctly aimed at the potential hazard and that no obstructions interfere with its line of vision. UV absorbing gases should not exist between the detector and the potential hazard.

CHECKOUT PROCEDURE

CAUTION

When testing the system, be sure to secure all output devices to prevent unwanted activation of this equipment and remember to place these same devices back into service when the check-out is complete.

MANUAL vi CHECK/COUNT TEST

The Automatic vi (visual integrity) feature checks the detectors for correct response.

The visual integrity test and the count test are performed at the same time.

1. Place the controller in the bypass mode (all outputs inhibited) by keeping the **MENU/SET** switch activated until '**Chc**' '**Err**' or '**bPS**' are shown on the digital displays. Release the switch and activate it again until '**bPS**' is shown on the right side of the display, then activate the **SELECT/RESET** switch. The right digital display will show '**Chn**' and the left side of the digital display will show '**bPS**'.
2. Activate the **MENU/SET** switch again to toggle through the available channels. When the desired channel is shown on the left side of the display, activate the **SELECT/RESET** switch.
3. While in the bypass mode, the right side of the display will show the counts per second produced by the background UV in the detector's range of vision. Activating the **SELECT/RESET** switch will perform the manual **vi** test, a significant increase in the count displayed should be observed. (Counts should be greater than 150 and less than 400. If the counts read are not within this range the lens and reflector need cleaning or the **vi** adjustment allen screw the sensor on module needs to be repositioned (only available on tube modules with aluminum shroud.)
4. To exit the bypass mode, activate the **MENU/SET** switch repeatedly until '**test**' is shown on the left side of the display. Now activate the **SELECT/RESET** switch.

NOTE

The Automatic **vi** system continuously monitors the operation of the detector but does not monitor external relays or equipment that may be operated from the relay outputs. It is important that the system be manually checked using the **MANUAL** check procedure on a regular basis. The whole system (including external equipment) should be checked periodically using a UV Test Lamp to simulate a fire.

MANUAL CHECK PROCEDURE

The whole system should be checked periodically with a UV test lamp to make sure that the detectors are not obstructed, that the area 'seen' by the detector has not changed and that there is no fault in the **vi** circuit.

1. Place the channel to be tested in bypass mode as described in the '**MAIN MENU**' section of this manual.
2. Direct the UV test light into a detector viewing window. The counts per second displayed on the right display should increase to an alarm level.
3. Turn off the UV source.
4. Repeat the test for all detectors in the system.
5. After all detectors have been checked, return the system to the normal operating mode.
6. Restore power to output loads or remove any mechanical blocking devices.

ALTERNATE TEST PROCEDURE

After each channel is offered for selection in the bypass mode a final **'test bPS'** selection is offered. All channels are now in the test bypass mode. In this mode the counts per second, normally seen when a channel is in bypass, are not seen and the Channel, Instant, and Area LEDs will operate as they would in the normal operating mode (ie. flash when a fire condition exists etc.), but the relay and current outputs are inhibited. This is an excellent way to test sensor sensitivity settings and to assure that if a fire occurs the controller will respond. Activate the **SELECT/RESET** switch, while in this mode, to return to the normal operating mode.\

NORMAL OPERATION

FIRE RESPONSE

When the controller receives a 'fire' signal from any detector in the system, it is compared to the stored information of the program. If the signal level is greater than the programmed sensitivity setting:

1. The instant alarm relay and the appropriate current output change status and the instant LED flashes.
2. The left side of the display cycles through all detectors responding to the fire (CH1, CH2, CH3, or CH4).
3. The right side of the digital display indicates a fire (**'Fir'**).
4. One or more channel LEDs turn on (blinking), indicating the channel(s) detecting UV radiation.

If the signal level is greater than the programmed sensitivity setting for longer than the preset time delay and the selected 'voting' criteria has been satisfied, the appropriate Area outputs change status and the corresponding Area LED is flashing. The bar graph display is also flashing.

NOTE

When a fire signal is no longer present, the channel LED(s) and the instant and area LEDs will be latched on until manually reset (LEDs are on, but no longer flashing).

Current Outputs

4-20 mA DC current outputs transmit system information to other devices. The current outputs can be wired for isolated or non-isolated operation by changing a jumper connection as shown in Figure 4. The current output can have a maximum external loop resistance of 600 ohms. Table 2 shows the current output levels for various situations.

Current Output	Situation
0 mA	Off or Shorted signal output, or loss of power
1 mA	Fault
2 mA	Power Fault
4 mA	Normal
5 mA	VI fault channel 1
6 mA	VI fault channel 2
7 mA	VI fault channel 3
8 mA	VI fault channel 4
9 mA	VI fault more than one channel
15 mA	Instant alarm channel 1
16 mA	Instant alarm channel 2
17 mA	Instant alarm channel 3
18 mA	Instant alarm channel 4
19 mA	Instant alarm more than one channel
19.5 mA	Fire (Area alarm)

Table 2 - Current Outputs

AUTOMATIC DIAGNOSTICS AND FAULT IDENTIFICATION

If a fault is detected:

- ▶ the Fault LED flashes,
- ▶ the digital displays identify that a fault has occurred,
- ▶ the current outputs change state,
- ▶ the fault relay output becomes de-energized, and
- ▶ if a specific individual detector fault is detected (example, wiring problems), the corresponding channel LED will be on.

Refer to Table 3 to identify the error messages. If more than one error is present, the message will continuously cycle through all the errors, changing every few seconds.

LEFT DISPLAY	RIGHT DISPLAY	ERROR	WHAT TO DO
290	gnd	Grounding problem with detector 290 Vdc supply.	Check wiring to detector, 290Vdc may be shorted to ground.
290	OLo	+290 Vdc detector power too low.	Contact Factory.
290	OHi	+290 Vdc detector power too high.	Contact Factory.
12	OUT	Internal 12 Vdc supply out of operating range. ¹	Recycle power and call factory if problem persists.
5	OUT	Internal 5 Vdc supply out of operating range. ¹	Recycle power and call factory if problem persists.
24H	OUT	Controller supply is greater than 32Vdc.	Check your power supply.
24L	OUT	Controller 24 Vdc supply is less than 18Vdc.	Check your power supply.
ch	OiH	Visual integrity error (Signal received is too high).	Contact Factory.
chx ²	OiL	Visual integrity error (Signal received is too low).	Clean detector window and reflector.
rSt	E71	Reset Reed Switch is damaged, or has been activated for more than 15 seconds.	Make sure no magnetic objects are in close proximity to the switch.
Ert	Err	External reset switch short error.	Make sure external reset switch is not damaged or shorted to ground.
CFg	Err	Configuration error; incorrect dip switch settings.	Check dip switch settings and recycle power.
E91	Err	System RAM error.	Contact Factory.
E92	Err	Power is not stable.	Contact Factory.
E94	Err	EEPROM data not correct.	Contact Factory.
E97	Err	EEPROM reading, or writing not correct.	Contact Factory.

Table 3 - Error Codes

- 1 If an internal power supply problem occurs, recycle power to the controller. If the problem persists, contact supplier.
- 2 If more than one channel has a vi error, the upper display will sequentially show each channel number.

If a fault has occurred, but no longer exists, the fault LED will remain illuminated and the displays will alternate between 'nor' and 'Err Fnd'. To find out what the fault was, enter the error check mode by keeping the **MENU/SET** switch activated until '**Chc Err**' is displayed, then activating the **SELECT/RESET** switch. The display should now show '**dSP Err**'. Activate the **SELECT/RESET** switch and the fault error codes are sequentially displayed. Once all faults have been displayed, '**Clr Err**' is displayed. To clear the fault codes, activate the **SELECT/RESET** switch.

MAIN MENU

The main menu is entered by activating the **MENU/SET** switch for approximately 5 seconds until '**Chc**' '**Err**' or '**bPS**' is shown on the displays. Repeatedly activating the **MENU/SET** switch will toggle through the selections. When the desired selection is shown on the displays, activate the

SELECT/RESET switch to choose the selection. To exit the main menu without choosing an option, toggle through the selections until 'rtn' is shown on the lower display.

ERROR CHECK MODE (Err Chc)

This is the first selection in the main menu. Enter the main menu and activate the **SELECT/RESET** switch when '**Chc**' is shown on the left side of the display and '**Err**' is shown on the right side of the display '**dsP**' will be shown on the left side of the display and '**Err**' on the right side of the display. To see the errors activate the **SELECT/RESET** switch. The controller will display each error for approximately 5 seconds. Once all errors have been shown, '**Clr**' will be shown on the left side of the display and '**Err**' on the right side. Activate the **SELECT/RESET** switch to clear the errors and return to the normal operating mode.

If it is not necessary to see what errors have been logged, but only to clear them, activate the **MENU/SET** switch when '**dsP**' '**Err**' is shown. The '**Clr**' '**Err**' selection will be displayed. Activate the **SELECT/RESET** switch to clear the errors and return to the normal operating mode.

NOTE:

If no errors exist, this function is hidden and can not be accessed.

BYPASS MODE (bPS)

This is the second selection in the main menu. It is used for testing detector operation without activating alarm outputs. To enter this mode, first enter the main menu, toggle through the selections using the **MENU/SET** switch and activate the **SELECT/RESET** switch when '**bPS**' is shown on the right side of the display '**Ch**' will be shown on the left side of the display and the UV seen by the detector is shown on the right side of the display in counts per second.

Activating the **SELECT/RESET** switch while a channel is in bypass will perform the manual **vi** test. A significant increase in the counts per second should be observed on the lower display. A range between 150 and 400 cps is expected.

Activating the **MENU/SET** switch will toggle through all of the active channels and then show '**test**' on the left side of the display and '**bPS**' on the right side of the display. In this manual test mode, all alarm outputs are inhibited, but the faceplate indicators will operate as in the normal operating mode. If a flame occurs or UV test lamp is used to activate the detectors the faceplate indicators operate as in the normal operating mode, but the alarm outputs will not activate. To exit the bypass mode, activate the **SELECT/RESET** switch while '**test bPS**' is displayed.

SPECIAL FUNCTION MENU

To enter the special function menu activate both switches simultaneously for 20 seconds, until '**FoP**' is shown on the right side of the display. This menu is a little harder to enter because it is not intended for general use. The items in this menu are used for system maintenance and calibration of equipment.

FORCED CURRENT OUTPUT MODE (FoP)

The forced current output mode is used to check the current output calibration and the operation of any devices connected to the current outputs.

To enter the forced current output mode, enter the special function menu. When '**FoP**' is shown on the right side of the display activate the **SELECT/RESET** switch. Upon successful entry into this mode the left side of the display will flash '**gPn**'. Activate the **MENU/SET** switch until the desired

area output is reached ('gPA' = Area 1 and 'gPb' = Area 2), then activate the **SELECT/RESET** switch.

When an area has been chosen for forced current output, the left side of the display will alternate between 'GPn' and 'FoP' and the right side of the display will show what type of current output is being placed on the current output line:

FLt	-> Fault (1mA)
POE	-> Power Error (2mA)
Nor	-> Normal (4mA)
OP1	-> Visual Integrity Error Channel 1 (5mA)
OP2	-> Visual Integrity Error Channel 2 (6mA)
OP3	-> Visual Integrity Error Channel 3 (7mA)
OP4	-> Visual Integrity Error Channel 4 (8mA)
OPA	-> Visual Integrity Error on more than one channel (9mA)
in1	-> Instant Alarm Channel 1 (15mA)
in2	-> Instant Alarm Channel 2 (16mA)
in3	-> Instant Alarm Channel 3 (17mA)
in4	-> Instant Alarm Channel 4 (18mA)
inA	-> Instant Alarm on more than one channel (19mA)
Fir	-> Area Alarm (19.5mA)

The controller will start with the Fault output and the Reed Switches are used to scroll up and down through the different outputs. To exit this mode, scroll down past the Fault output selection until 'rtn' is displayed then wait 10 seconds. The controller will return to the normal operating mode.

CURRENT CALIBRATION MODE (CuC)

The next selection in the special function menu is the current calibration mode. This mode is selected to calibrate the current outputs. Upon successful entry into this mode the left side of the display will flash 'gPn'. Activate the **MENU/SET** switch until the desired area output is reached ('gPA' = Area 1 and 'gPb' = Area 2), then activate the **SELECT/RESET** switch. Once an area has been selected, the left side of the display will alternate between 'CuC' and the area that is being calibrated. The lower display will show a constant which will rise and fall as the current is adjusted (constant does not show the current on the outputs), and the instant LED will flash. Place a milliamp meter between the Area current output and common ground. Use the Reed Switches to raise and lower the current. Once the current measured is as close to 4mA as possible, do not activate any switches for 10 seconds. After 10 seconds have gone by the number shown on the right side of the display will change to a much higher number. The instant LED will be extinguished and the area LED will begin flashing. This tells the operator to calibrate the current output for the high end of the current output range. Use the Reed Switch to raise or lower the current output until it is as close as possible to 20 mA. Do not activate any switches for 10 seconds and the controller will return to the normal operating mode.

ADDRESS SET MODE (Adr Set) (Do not use)

Do not use the final selection in the special function menu which is to set the controllers address for the CAN system. When the left side of the display shows 'Adr' and the right side of the display shows 'SEt' activate the **SELECT/RESET** switch. The left side of the display will alternate between 'Adr' and 'SEt' and the right side of the display will show the current address. Use the Reed Switch to raise and lower the address. Once the address is correct, do not activate any switches for 10 seconds and the controller will return to the normal operating mode.

Unit V MAINTENANCE

ROUTINE MAINTENANCE

The detector requires no periodic calibration. To maintain maximum sensitivity, the viewing windows should be cleaned on a routine basis depending on the type and amount of contaminants in the area.

The rubber O-rings on the detector housing are used to ensure it is watertight. The housings should be opened periodically and the O-rings inspected for breaks, cracks or dryness. To test them, remove the O-rings from the detector housing and stretch them slightly. If cracks are visible, the O-ring should be replaced. If they feel dry to the touch, a thin coating of lubricant should be applied. When re-installing the O-rings, be sure that they are properly seated in the groove on the housing.

These O-rings must be properly installed and in good condition to prevent water from entering the detector and causing failure. The life expectancy of rubber O-rings varies, depending on the type and amount of contaminants present in the area. The person who maintains the system must rely on experience and common sense to determine how frequently the rings should be inspected. A coating of lubricant should also be applied to the enclosure threads before reassembling the detector to help prevent moisture from entering.

CAUTION

The O-ring should be lubricated with polyalphaolefin grease, such as GRS-450 made by CPI Engineering. Silicone based lubricants should never be used if catalytic type combustible gas sensors are being used in conjunction with the UV detectors, since silicone lubricant on or near the combustible gas sensor will cause permanent damage to the sensing element.

TROUBLESHOOTING

The Automatic vi (visual integrity) feature continuously checks the detectors for correct response. If a problem is detected, the fault LED will turn on, the left side of the digital display will indicate which channel has the problem and the right side of the digital display will show "OIL" or "OIH" The fault relay will become de-energized.

If a fault is in the detector or wiring, the left side of the display will indicate which detector is affected. The right side of the display will indicate by code number the type of fault. If the fault is in the microprocessor circuitry, the fault LED will turn on, but the left side of the digital display will remain blank. Refer to Table 3 for a detailed explanation of the status/fault codes.

DEVICE REPAIR AND RETURN

The detector and controller are not designed to be repaired by the customer in the field. If a problem should develop, first carefully check for proper wiring and programming. If it is determined that the problem is caused by an electrical malfunction, the unit must be returned to the factory for repair.

Net Safety Monitoring Inc encourages its distributors to make advance replacement units available to the user during the warranty period. This allows Net Safety Monitoring Inc. to take time to repair the unit completely while users keep their operations running with the advance replacement unit.

Prior to returning items, contact the nearest distribution office so that an RMI (Return Material Identification) number can be assigned. A written statement describing the malfunction must accompany the returned item to simplify finding the cause of the failure and reduce the time and cost of the repair. Pack the item to protect it from damage and use an anti-static bag or aluminum-backed cardboard as protection from electrostatic discharge.

APPENDICES

Appendix A Net Safety Monitoring Inc. Electrostatic Sensitive Device Handling Procedure

With the trend toward increasingly widespread use of microprocessors and a wide variety of other electrostatic sensitive semiconductor devices, the need for careful handling of equipment containing these devices deserves more attention than it has received in the past.

Electrostatic damage can occur in several ways. The most familiar is by physical contact. Touching an object causes a discharge of electrostatic energy that has built up on the skin. If the charge is of sufficient magnitude, a spark will also be visible. This voltage is often more than enough to damage some electronic components. Some devices can be damaged without any physical contact. Exposure to an electric field can cause damage if the electric field exceeds the dielectric breakdown voltage of the capacitive elements within the device.

In some cases, permanent damage is instantaneous and an immediate malfunction is realized. Often, however, the symptoms are not immediately observed. Performance may be marginal or even seemingly normal for an indefinite period of time, followed by a sudden and mysterious failure.

Damage caused by electrostatic discharge can be virtually eliminated if the equipment is handled only in a static safeguarded work area and if it is transported in a package or container that will render the necessary protection against static electricity. Net Safety Monitoring Inc. modules that might be damaged by static electricity are carefully wrapped in a static protective material before being packaged. Foam packaging blocks are also treated with an anti-static agent. If it should ever become necessary to return the module, it is highly recommended that it be carefully packaged in the original carton and static protective wrapping.

Since a static safeguarded work area is usually impractical in most field installations, caution should be exercised to handle the module by its metal shields, taking care not to touch electronic components or terminals.

In general, always exercise all of the accepted and proven precautions that are normally observed when handling electrostatic sensitive devices.

A warning label is placed on the packaging, identifying those units that use electrostatic sensitive semiconductor devices.

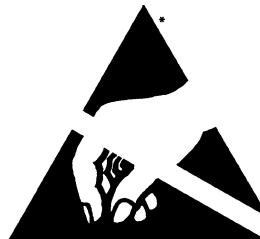

**Published in Accordance with E1A
standard 471*

Appendix B Procedure For Activating Reed Switches

When activating the **MENU/SET** and **SELECT/RESET** reed switches, it is important to orient the magnets provided with the device in the proper direction. They are to be positioned on the faceplate with the curved edge facing the glass. Do not place the flat surface of the magnet against the faceplate. Refer to the diagrams below.

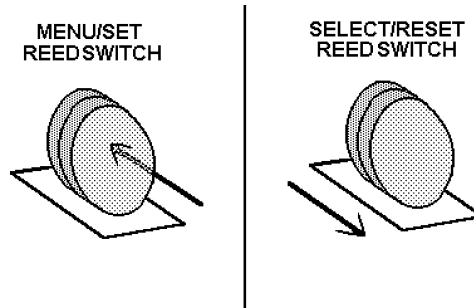

Appendix C Record Of Dip Switch Settings

DIP SWITCH	ON	OFF
SW3.1		
SW3.2		
SW3.3		
SW3.4		
SW3.5		
SW3.6		
SW3.7		
SW3.8		
SW4.1		
SW4.2		
SW4.3		
SW4.4		
SW4.5		
SW4.6		
SW4.7		
SW4.8		
SW5.1		
SW5.2		
SW5.3		
SW5.4		
SW5.5		
SW5.6		
SW5.7		
SW5.8		

Appendix D Common Ultra-Violet Absorbing Gases

Since the UVC120 fire detector is designed to detect fires by responding to the ultra-violet (UV) radiation they emit, it is very important to be aware of UV absorbing gases that may be present between the detector and the sources of potential fires. Small concentrations of these types of gases may not absorb enough UV radiation to cause a problem, but when higher concentrations of these gases are present the detectors may become blind as not enough ultra-violet radiation can reach them to activate an alarm. Moving detectors closer to the probable source of fire and increasing the sensitivity of the detector can help to overcome this problem in some cases. Following is a list of common UV absorbing gases:

*Acetaldehyde
Acetone
Acrylonitrile
Ethyl Acrylate
Methyl Acrylate
Ethanol
Ammonia
Aniline
Benzene
1,3 Butadiene
2-Butanone
Butylamine
Chlorobenzene
1-Chloro-1-Nitropropane
Chloroprene
Cumene
Cyclopentadiene
O-Dichlorobenzene
P-Dichlorobenzene*

*Methyl Methacrylate
Alpha-Methylstyrene
Naphthalene
Nitroethane
Nitrobenzene
Nitromethane
1-Nitropropane
2-Nitropropane
2-Pentanone
Phenol
Phenyl Glycide Ether
Pyridine
Hydrogen Sulfide
Styrene
Tetrachloroethylene
Toluene
Trichloroethylene
Vinyl Toluene
Xylene*

Appendix E Wire Resistance In Ohms

DISTANCE (FEET)	AWG #20	AWG #18	AWG #16	AWG #14	AWG #12	AWG #10	AWG #8
100	1.02	0.64	0.40	0.25	0.16	0.1	0.06
200	2.03	1.28	0.80	0.51	0.32	0.2	0.13
300	3.05	1.92	1.2	0.76	0.48	0.3	0.19
400	4.06	2.55	1.61	1.01	0.64	0.4	0.25
500	5.08	3.2	2.01	1.26	0.79	0.5	0.31
600	6.09	3.83	2.41	1.52	0.95	0.6	0.38
700	7.11	4.47	2.81	1.77	1.11	0.7	0.44
800	8.12	5.11	3.21	2.02	1.27	0.8	0.5
900	9.14	5.75	3.61	2.27	1.43	0.9	0.57
1000	10.2	6.39	4.02	2.53	1.59	1.09	0.63
1250	12.7	7.99	5.03	3.16	1.99	1.25	0.79
1500	15.2	9.58	6.02	3.79	2.38	1.5	0.94
1750	17.8	11.2	7.03	4.42	2.78	1.75	1.1
2000	20.3	12.8	8.03	5.05	3.18	2	1.26
2250	22.8	14.4	9.03	5.68	3.57	2.25	1.41
2500	25.4	16	10	6.31	3.97	2.5	1.57
3000	30.5	19.2	12	7.58	4.76	3	1.88
3500	35.5	22.4	14.1	8.84	5.56	3.5	2.21
4000	40.6	25.5	16.1	10	6.35	4	2.51
4500	45.7	28.7	18.1	11.4	7.15	4.5	2.82
5000	50.1	32	20.1	12.6	7.94	5	3.14
5500	55.8	35.1	22.1	13.91	8.73	5.5	3.46
6000	61	38.3	24.1	15.2	9.53	6	3.77
6500	66	41.5	26.1	16.4	10.3	6.5	4.08
7000	71.1	44.7	28.1	17.7	11.1	7	4.4
7500	76.1	47.9	30.1	19	12	7.49	4.71
8000	81.2	51.1	32.1	20.2	12.7	7.99	5.03
9000	91.4	57.5	36.1	22.7	14.3	8.99	5.65
10 000	102	63.9	40.2	25.3	15.9	9.99	6.28

NOTE: RESISTANCE SHOWN IS ONE WAY. THIS FIGURE SHOULD BE DOUBLED WHEN DETERMINING CLOSED LOOP RESISTANCE.



2721 Hopewell Place NE
Calgary, Alberta, Canada T1Y 7J7
Telephone: (403) 219-0688 Fax: (403) 219-0694
www.net-safety.com
E-mail: netsafe@net-safety.com