



2002 FOX FORX Owners Manual

FLOAT 80R - FLOAT 80RL - FLOAT 80RLC
FLOAT 100R - FLOAT 100RL - FLOAT100RLC
Vanilla 100R - Vanilla 100RL - Vanilla 100RLC
Vanilla 125R - Vanilla 125RL - Vanilla 125RLC

FOX RACING SHOX

130 Hangar Way, Watsonville, CA 95076

831.768.1100 FAX 831.768.9342

E-Mail: service@foxracingshox.com

Website: www.foxracingshox.com

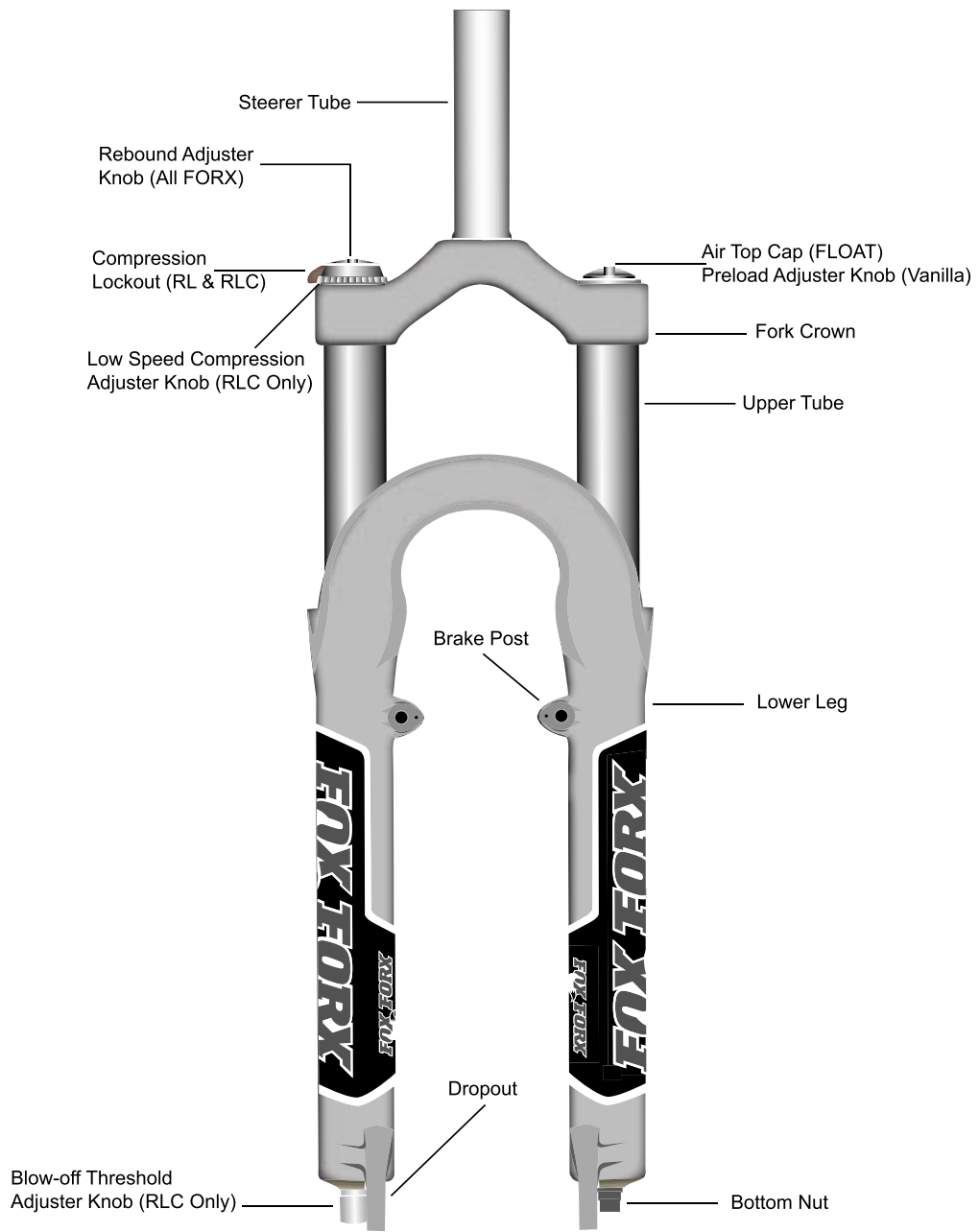

FLOAT Forx Features

One-piece Magnesium Lower Leg
 Double butted Aluminum Steerer
 PSC - Precision Steering Control
 CLS - Coil Lubrication System
 SDC - Shimmed Damping Control
 Rebound Adjustment
 FLOAT Air Spring Technology
 Adjustable Travel- 80&100mm

Vanilla Forx Features

One-piece Magnesium Lower Leg
 Double butted Aluminum Steerer
 PSC - Precision Steering Control
 CLS - Coil Lubrication System
 SDC - Shimmed Damping Control
 Rebound Adjustment
 Vanilla Coil Spring Technology
 Adjustable Travel - 80, 100 &125mm

Table of Contents

Introduction	4
Contact Information	4
Service / Warranty	4
International Service Centers	4
Warranty Policy	5
Methods of Payment	5
Method of Shipping	5
Disclaimer	5
Consumer Safety	5
Important Safety Information	6
Installation	6
Tire Sizes	7
Brakes	7
Maintenance	7
Service Intervals	8
Pump	8
General Set-Up Instructions	9
Fork Terminology	9
Sag & Spring Tuning	
Vanilla Forx	9
FLOAT Forx	10
Damping Adjustment Guidelines	11
Changing Travel	
FLOAT Forx	12
Vanilla Forx	13
Changing Oil	14
Seals and Foam Rings	16
International Versions	
Français	17
Italiano	33
Deutsch	49
Español	65
Japanese	81

Introduction

Congratulations on choosing FOX FORX for your bicycle. In doing so, you have chosen the best suspension fork in the industry! All FOX Racing Shox products are designed, manufactured and assembled by the finest professionals in the industry. As a consumer and supporter of FOX Racing Shox products, you need to be aware of the importance of setting up your fork correctly to ensure maximum performance. This manual will provide you with the step-by-step instructions of how to set up your fork. It is a good idea to keep your receipts with this manual and refer to it for service and warranty issues.

Contact Information

FOX Racing Shox 130 Hangar Way Watsonville, CA 95076	Phone: 831.768.1100 North America: 800.369.7469 Fax: 831.738.9312
E-mail: service@foxracingshox.com	Website: www.foxracingshox.com
Business Hours: Monday-Friday 8:00AM-5:00PM Pacific Time	

Service / Warranty

FOX Racing Shox is pleased to offer 48-hour* turnaround for product service, provided the following steps are taken.

1. Contact FOX Racing Shox at 800.FOX.SHOX to obtain a Return Authorization (R.A.) Number and shipping address. For International Service Centers, please refer to the list below or contact FOX Racing Shox to determine the Service Center nearest you.
2. Satisfactory proof of purchase receipt is required for warranty consideration.
3. Mark the Return Authorization Number and the Return Address clearly on the outside of the package and send item to FOX Racing Shox or your International Service Center with shipping charges pre-paid by sender.
4. Include a description of the problem, bicycle information (manufacturer, year and model), type of FOX product, spring rate and return address with daytime phone number.

*International Service Centers operate independently. Service and Warranty turnaround times may vary.

International Service Centers			
Country	Name	Phone Number	E-mail
Australia	Dirt Works	612-9679-8400	dirtworks@dirtworks.com.au
Belgium	Sabma	087-631980	sabma@skynet.be
Brazil	Plimax 2 Fast	5511-251-0633	Plimax@nw.com.br
Canada West	Cycle Works	780-440-3200	mail@cycleworks.com
Canada East	Velo Cycle	514-849-5299	info@velocycle.com
France	F.M.F. France	33-494-54-1950	fmsportgroup@wanadoo.fr
Germany	Shock Therapy	49-6126-22677-00	support@shock-therapy.com
Italy	Pepi Innerhofer	39-0473-56-3107	info@pepi.it
Japan	Mom & Pop's	81-586-43-6810	mamapapa@mtg.biglobe.ne.jp
New Zealand	Blue Shark Ent.	64-4589-4535	alastair@mountainbikes.co.nz
Spain	Dirt Racing	34-91-663-71-25	mrojo.dirt@nexo.es
Switzerland	FOX Racing Euro	41-31-809-3020	frs-europe@bluewin.ch
United Kingdom	Mojo Suspension	44-1633-615-815	chris.porter@virgin.net
United States	FOX Racing Shox	831.768.1100	service@foxracingshox.com

Warranty Policy

The factory warranty period for your fork is one year from the original date of purchase of the bicycle or fork. A copy of the original purchase receipt must accompany any fork being considered for warranty service. Warranty is at the full discretion of FOX Racing Shox and will cover only defective materials and workmanship. This warranty is void when damage to the fork has occurred from the following:

- Abuse
- Seal damage due to power washing
- Damage to the exterior finish caused by improper cable routing, rocks, crashes, dents
- Any attempt to disassemble damper assembly
- Modifications
- Non-Factory oil use or improper service
- Shipping damages or loss (purchase of full value insurance is recommended)

To ensure peak performance, repairs and service to the fork must be performed by FOX Racing Shox in the USA or outside the USA by a FOX Racing Shox Authorized Service Center.

FOX Racing Shox reserves the right to all final warranty or non-warranty decisions.

Method of Payment

Visa, MasterCard and/or Cashier's Check

Method of Shipping

FOX Racing Shox uses UPS Ground service within the USA.

Disclaimer

FOX Racing Shox is not responsible for any damages to you or others arising from riding, transporting, or other use of your fork or bicycle. In the event that your fork breaks or malfunctions, FOX Racing Shox shall have no liability or obligation beyond the repair or replacement of your fork, pursuant to the terms outlined in the Service and Warranty provisions of this Manual.

Consumer Safety

RIDING A BICYCLE IS DANGEROUS AND CAN RESULT IN DEATH OR SERIOUS INJURY. TAKE YOUR RESPONSIBILITY TO YOURSELF AND OTHERS SERIOUSLY.

- Maintain your bicycle and suspension
- Always wear a helmet, protective clothing and eye protection
- Ride within your limits
- Tread lightly

Your bike is equipped with FOX Racing Shox suspension. Before riding, take the time to read the FOX Racing Shox manual on setup, use, and service of your fork. If you have questions, call your Authorized FOX Racing Shox Service Center or call FOX Racing Shox directly at 831.768.1100.

If your fork ever loses oil, or if it makes unusual noise, stop riding immediately and have the fork inspected by a dealer, Service Center or contact FOX Racing Shox. **RIDING WITH A BROKEN OR MALFUNCTIONING FORK CAN RESULT IN LOSS OF CONTROL, CRASHING, AND POSSIBLE DEATH OR SERIOUS INJURY.**

Never modify your bike frame or fork. Only use genuine FOX Racing Shox parts for your fork. Any modification, improper service, or use of after-market replacement parts will void the warranty and could damage the fork or cause loss of control of the bike resulting in serious injury or death.

Follow the scheduled service recommendations in this manual. Always have your fork serviced by a qualified bicycle mechanic, dealer or Authorized FOX Racing Shox Service Center.

Important Safety Information

1. Verify that the brakes are installed and adjusted properly before riding the bicycle. Improperly installed or adjusted brakes can cause loss of control and serious or fatal injuries to the rider. Use only "V" - style or hydraulic cantilever brakes or disc brakes designed by the manufacturer for use on FOX FORX. Do not use brace mounted cable leverage devices. Do not route brake cables or housing through the stem.
2. If your fork loses oil, tops out excessively or makes unusual noises, immediately stop riding and contact FOX Racing Shox or an Authorized FOX Racing Shox Service Center for inspection. Continued use of the fork could cause loss of control and serious or fatal injuries.
3. Use only FOX Racing Shox replacement parts. Using aftermarket parts on FOX FORX will void the warranty. Aftermarket replacement parts could also cause structural failure resulting in loss of control and serious or fatal injuries.
4. If mounting the bicycle in a carrier designed to hold a fork by its drop-outs, use caution to not tilt the bicycle to either side. Tilting the bike with the drop-outs in the carrier can cause structural damage to the fork. Ensure that the fork is fastened securely with the quick release and that the rear wheel is properly held. If the bicycle ever tilts or falls from a bicycle carrier, do not ride it until it is examined by a qualified dealer, Service Center or FOX Racing Shox. A fork leg or drop-out failure could cause loss of control and serious or fatal injuries.
5. FOX FORX do not include reflectors for on-road use. FOX FORX are designed to be used in competitive off-road riding and racing. Proper reflectors meeting the Consumer Product Safety Commission's (CPSC) requirements should be installed if the fork will be used on public roads.

6. FOX FORX have a crown / steerer / upper tube assembly. These parts are pressed together in a one-time, precision press-fit operation. Replacement of any of these parts requires a complete new assembly. Do not attempt to remove or replace the steerer or upper tubes independently of the crown. DO NOT ATTEMPT TO ADD THREADS TO THREADLESS STEERERS. Modifying the crown / steerer / upper tube assembly as described here could cause the rider to lose control of the bicycle resulting in serious or fatal injuries.

Installation

Step 1 - Your FOX FORX should be installed by a qualified bicycle mechanic. Forks installed improperly are dangerous and can cause loss of control and serious or fatal injuries.

Step 2 - Remove existing fork from the bicycle. Remove the crown race from the fork. Measure the steerer tube length of the existing fork. Transfer this measurement to the FOX FORX steerer. Refer to stem manufacturer's instructions to be sure there will be enough clamping surface for the stem. If it is necessary to cut the steerer tube, measure twice and cut once. It is also recommended that a cutting guide be used while cutting the steerer tube.

Step 3 - Use a crown race setter to install the crown race firmly against the top of the crown. Install the star fangled nut in the steerer tube. This should be done with a star fangled nut installation tool.

Step 4 - Install the fork on the bicycle. The headset should be adjusted so it turns freely without drag or free play.

Step 5 - Re-install the brakes and adjust the brake pads. Refer to the brake manufacturer's instructions.

Step 6 - Mount the front wheel being sure that the quick release nuts sit in the fork drop-out counter bores. The quick release should engage four (4) or more threads. Close the quick release with the lever in front of and parallel to the left fork leg.

Tire Sizes

FOX FORX will accept tires sizes up to 2.40 inches wide (e.g. WTB MotoRaptor 55/60, 26 x **2.40**). Any tire larger than 26 x 2.30 must be checked for clearance by the following method.

Determining Tire Size - With the tire installed and inflated on the rim, measure the following three dimensions.

Maximum Peak Tire Diameter = 343mm = 27.00 inch
Maximum Edge Tire Diameter = 326mm = 25.67 inch
Maximum Tire Width = 61mm = 2.40 inch

Do not use a tire if ANY measurement exceeds the maximum dimensions shown above. Using tires larger than the dimensions shown above is NOT RECOMMENDED and can cause serious or fatal injury.

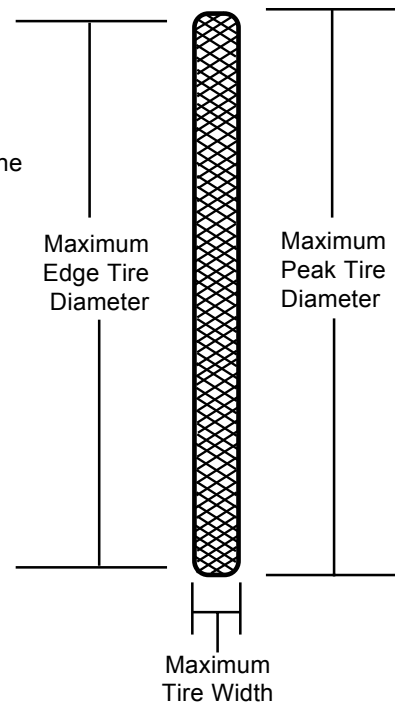

Brakes

Linear-pull Brakes

Linear-pull brakes (i.e. V-brakes) can be used on FOX FORX. Use only the FOX brake posts supplied with the fork. Install brake posts and torque to 80 in-lbs. Install and adjust linear-pull brakes according to the manufacturer's recommendations. Test brakes for proper operation on flat land. FOX FORX use a **hangerless lower leg** design and cannot use any cantilever style brakes.

Disc Brakes

Disc brakes with 160-180mm rotors can be used on FOX FORX. **Do not use DH rotors larger than 180mm.** Install disc brakes and torque all fasteners according to manufacturer's recommendations. Install, route and check that all cables or hydraulic hoses are securely fastened to the lower leg and will not move during compression of the fork. Test brakes for proper operation on flat land.

Maintenance

Performance, safety and the life-span of your FOX FORX depend on maintenance. If you ride in extreme conditions, service and maintain your FOX FORX more frequently.

NOTE: In this manual, reference being made to the left and right side of the fork is from the seated rider's perspective.

Important Check Before Every Ride

1. Check that quick release skewer is properly adjusted and tight.
2. Clean the outside of your fork with soap and water and wipe dry with a soft dry rag. Do not spray water directly on the Seal/Uppertube junction. **DO NOT USE A HIGH PRESSURE WASHER ON YOUR FORK.**
3. Inspect entire exterior of fork for damage. The fork should not be used if any of the exterior parts appear to be damaged. Please contact your local dealer or FOX Racing Shox for further inspection and repair.
4. Check headset adjustment. Adjust headset if loose according to manufacturer's recommendations.
5. Check that brake cables or hoses are properly fastened.
6. Check that the front and rear brakes operate properly on flat land.

Service Intervals

Your FOX FORX will perform best if serviced at the regular intervals shown below.

Item	After Each Ride	Every 25 Hours	Every 100 Hours	Annually	Instructions found on:
Wash and Dry Exterior of Fork	X				page 7
Clean Fork Seals & Inspect / Lube Foam Rings		X			page 16
Clean and Refill FLOAT Fluid in Air Chamber (FLOAT Forx Only)			X		page 15
Bushing Wear Inspection				X	page 14
Change Fork Oil				X	page 14

Required Tools and Supplies

Torque Setting

Used for:

Safety Glasses	n/a	Protecting Eyes
Bucket or Drain Pan	n/a	Changing Oil / Travel
Paper towels and/or rags		Absorbing oils & fluids
Plastic Faced Mallet	n/a	Tap loose bottom shafts
Torque Wrench	n/a	Torque fasteners
FOX Suspension Fluid	n/a	Travel change (FLOAT Forx)
		Oil change (All Forx)
FOX FLOAT Fluid	n/a	Travel & Oil change (FLOAT Forx)
FOX High Pressure Air Pump	n/a	Setting air pressure (FLOAT Forx)
26mm 6 point socket	165 in-lbs (1864 N-cm)	All Topcaps
10mm open-end or socket wrench	50 in-lbs (565 N-cm)	All Bottom Nuts
8mm Crawfoot socket wrench	80 in-lbs (904 N-cm)	Brake Posts
3/8" Deep socket wrench	75 in-lbs (847 N-cm)	Air Tank Valve (FLOAT Forx)
Schrader valve core wrench	4 in-lbs (45 N-cm)	Schrader Valve Core (FLOAT Forx)
2mm Hex-key wrench	11 in-lbs (124 N-cm)	Rebound Knob (R, RL, RLC)
	4 in-lbs (45 N-cm)	Blow-off Threshold Knob (RLC)
1.5mm Hex-key wrench	Seated, back-off 1/4 turn	Lockout Lever (RL, RLC)

Pump

A FOX high pressure air pump is available for FLOAT Forx. It is used to make changes in air pressure on your fork.

1. Remove the air topcap from the top of the left fork leg.



2. Thread the pump's valve chuck onto the fork's air-valve until pressure registers on the pump gauge. This takes approximately 6 turns. Do not over-tighten pump on air-valve as this will damage the pump chuck seal.
3. **To increase the pressure**, stroke the pump a few cycles. The pressure should increase slowly. If pressure increases rapidly check to make sure the pump is properly fitted and tightened onto the air valve.

Note: If the fork has no air pressure, the gauge will not register pressure.

4. To decrease the pressure push the black bleed-valve. Pushing the bleed-valve halfway down, and holding it there, will allow pressure to escape from the pump and fork. Pushing the bleed-valve all the way down and releasing it will release a small amount of pressure (micro-adjust). When unthreading the pump from the air-valve fitting, the sound of the air loss is from the pump hose, not the fork itself.

Note: When attaching the pump to the fork, the hose will need to fill with air. This will result in a lower pressure registering approximately 10 to 20 PSI on the gauge.

Note: Average setting range is from 45 to 125 PSI. DO NOT EXCEED 200 PSI.

5. Replace the air topcap before riding.

General Set-Up Instructions

Fork Terminology

Travel: The total amount the fork compresses.

Sag: The amount the fork compresses with the rider sitting on the bike in a normal riding position.

Compression Damping: This controls the rate at which the fork compresses

Rebound Damping: This controls the rate at which the fork extends.

Preload: The initial force placed on a spring.

Spring Rate: The amount of force required to compress a spring one inch.

FLOAT: This is FOX air spring technology.

Vanilla: This is FOX coil spring technology.

Vanilla Forx

Setting Sag on Vanilla Forx

To get the best performance from your FOX Vanilla fork, it is necessary to set and adjust sag. Sag is how much the fork compresses or “sags” when the rider sits on the bicycle. Generally, this is 15-25% of the total travel.

Measuring and adjusting sag

1. Install a zip tie on the upper tube and push it down until it contacts the fork seal. Carefully sit on the bike and assume a normal riding position. The fork should compress slightly. Being careful not to further compress the fork, dismount the bicycle. Measure the distance between the seal and the zip tie. This distance is the sag.

2. Compare your sag measurement to the table.

If your sag is lower than on the table, turn the preload knob counter-clockwise one (1) full turn. Measure sag again and repeat adjustment if necessary.

If your sag is higher than on the table, turn the preload knob clockwise one (1) full turn. Measure sag again and repeat adjustment if necessary.

If correct sag cannot be achieved by adjusting the preload knob, see the Spring Tuning Guide below.

Vanilla Forx Sag Table	
Travel	Sag
80mm	16mm (5/8")
100mm	20mm (13/16")
125mm	25mm (1")

Spring Tuning on Vanilla Forx

Read the Vanilla Spring Tuning Guide chart below to see if you need to change your spring rate. Vanilla Forx are tuned by changing only the left side coil spring.

The coil spring has a painted color code stripe on one end of the spring.

Refer to the chart to select the optimum spring.

Vanilla Spring Tuning Guide

Symptom	Do the following:
Measured sag is too low and Preload Knob is adjusted fully counter-clockwise.	Increase spring rate
Excessive bottoming of travel during riding.	Increase spring rate
Measured sag is too high and Preload Knob is adjusted fully clockwise.	Decrease spring rate
Ride is too harsh and never use full travel.	Decrease spring rate

Vanilla Forx Spring Chart				
FOX Part #	Spring Rate	Color Code	Travel Range	Notes
039-05-000-A	10 lb/in	Black	80-100-125	
039-05-007-A	18 lb/in	Purple	80-100-125	
039-05-001-A	25 lb/in	Blue	80-100-125	Standard on Vanilla 125
039-05-002-A	35 lb/in	Green	80-100-125	Standard on Vanilla 100
039-05-003-A	45 lb/in	Yellow	80-100-125	Standard for 80mm travel
039-05-004-A	60 lb/in	Orange	80-100 only	
039-05-005-A	75 lb/in	Red	80-100 only	

Changing your Coil Spring

1. With a 26mm 6-point socket wrench, loosen and remove the preload topcap. Remove the black spring spacers (two spacers for 125mm travel, 1 for 100mm travel, none for 80mm travel). Compress the fork slightly and remove the coil spring. You may need to firmly pull up on the spring to disengage it from the plunger shaft. Wipe the spring dry with a rag and check the color code.
2. Install the new spring by dropping it into the upper tube. Install the spacer(s). Install and torque the topcap to 165 in-lbs (1864 N-cm).
3. Measure and adjust sag as described on page 10. Happy Trails!

FLOAT Forx

Setting Sag on FLOAT Forx

To get the best performance from your FOX FLOAT fork, it is necessary to set and adjust sag. Sag is how much the fork compresses or “sags” when the rider sits on the bicycle. Generally, this is 15-25% of the total travel.

Measuring and adjusting sag

1. Install a zip tie on the upper tube and push it down until it contacts the fork seal. Carefully sit on the bike and assume a normal riding position. The fork should compress slightly. Being careful not to further compress the fork, dismount the bicycle. Measure the distance between the seal and the zip tie. This distance is the sag.
2. Compare your sag measurement to the table.

If your sag is lower than on the table, remove the air topcap, screw on the FOX High Pressure Air Pump fitting, note the current air pressure setting and depress the black bleed-valve to reduce the gauge pressure by 5 psi. Measure sag again and repeat adjustment if necessary.

If your sag is higher than on the table, remove the air topcap, screw on the FOX High Pressure Air Pump fitting, note the current air pressure setting and pump to increase the gauge pressure by 5 psi. Measure sag again and repeat adjustment if necessary.

FLOAT Forx Sag Table		
TRAVEL	XC/Race Firm	Freeride Plush
80mm	12mm (1/2")	20mm (13/16")
100mm	15mm (9/16")	25mm (1")

Air Spring Tuning on FLOAT Forx

Read the FLOAT Air Spring Tuning Guide chart below to see if you need to change your air pressure. FLOAT Forx are tuned by changing air pressure at the left topcap. (See page 8 for instructions for the FOX High Pressure Air Pump)

FLOAT Air Spring Tuning Guide

Symptom	Do the following:
Measured sag is too low.	Increase air pressure by 5 psi
Excessive bottoming of travel of travel during riding.	Increase air pressure by 5 psi
Measured sag is too high.	Decrease air pressure by 5 psi
Ride is too harsh and never use full travel.	Decrease air pressure by 5 psi

FLOAT Air Spring Guidelines	
Rider Weight	Air Pressure
Under 125 lbs	45 psi
125 - 135 lbs	50 psi
135 - 145 lbs	55 psi
145 - 155 lbs	65 psi
155 - 170 lbs	75 psi
170 - 185 lbs	85 psi
185 - 200 lbs	95 psi
200 - 215 lbs	105 psi
215 - 230 lbs	115 psi
230 - 250 lbs	125 psi

Damping Adjustment Guidelines

Rebound Adjustment (R, RL, RLC)

FOX FORX feature a rebound adjuster. This allows the rider to control the speed at which the fork extends after compression. The Rebound Adjustment Knob is the red knob located on top of the right fork leg. Turn it clockwise for slower rebound and counter-clockwise for faster rebound. There are 12 clicks of adjustment in the full range of motion. The proper rebound setting is a personal preference and varies depending upon spring preload, spring rate and riding style. Rebound should be as fast as possible without kicking back. If the rebound is too slow the suspension will not function properly and the wheel will not follow the changing terrain. Determining the proper rebound setting may take a few rides to fine tune. On those first few rides adjust the rebound and note the different ride characteristics. Your rebound adjustment may change for different riding conditions. *As a starting point for tuning your rebound adjustment, turn the rebound adjuster knob all the way clockwise until it stops, then turn counter-clockwise 6 clicks.*

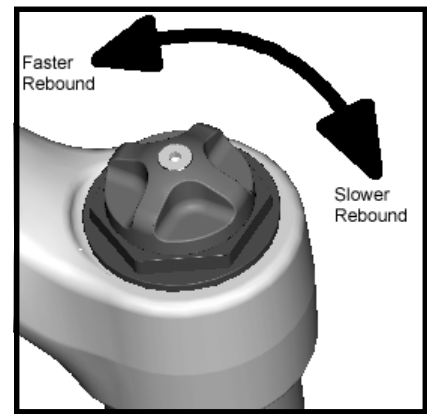

R

Compression Lock-out Lever (RL, RLC)

The blue compression lock-out lever is located below the red rebound adjuster knob. It allows the rider to close the compression damping in the fork. This keeps the fork at the top of its travel and it will be hard to compress. The fork is said to be "locked-out" in this position. Rotate the lever clockwise to the six o'clock position to achieve lock-out. This position is useful in climbing and sprinting situations. The fork will "blow-off" in the event that a big hit is encountered with the fork locked-out. To unlock the fork, simply rotate the lever counter-clockwise to the three o'clock position. This puts the cartridge in "open" mode and you will have normal compression damping. The lock-out lever will rotate past the three o'clock position. This is normal and does not affect performance.

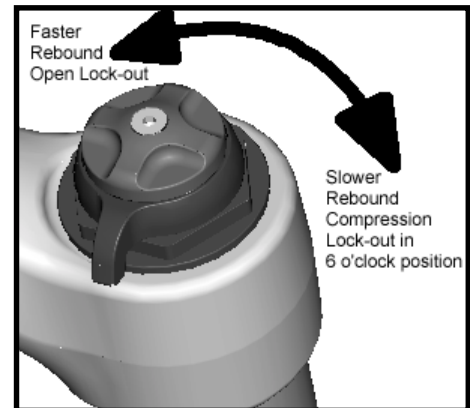

RL

Note: The fork may cycle a couple times after activating the lock-out. Once complete lock-out is achieved, the fork may continue to move 3-5mm. This is normal and does not affect performance.

Compression Adjustment (RLC Only)

Low-speed compression damping is adjusted with the blue bezel ring below the blue lockout lever. Compression damping controls the quickness with which the fork moves through its travel. Rotate the bezel clockwise for slower (harder) compression and counter-clockwise for faster (easier) compression. There are 9 clicks of adjustment. The proper setting is a personal preference and varies depending on your weight and riding style. Determining the proper compression setting may take a few rides to fine tune. On those first few rides adjust the compression and note the different ride characteristics. Your compression damping setting may change with different riding conditions. *As a starting point for tuning your compression, turn the bezel clockwise until it stops, the back off 5 clicks.*

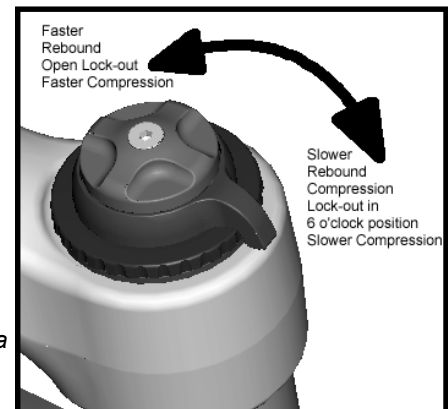

RLC

Blow-off Threshold Adjustment (RLC Only)

FLOAT RLC and Vanilla RLC feature Blow-off Threshold Adjustment capabilities. It is adjusted with the blue knob located at the bottom of the right fork leg. This gives the rider the ability to adjust the force required to cause the fork to blow-off when it is in the locked-out position. Turn the knob clockwise to make it harder to blow-off and counter-clockwise to make it easier. There are twelve (12) clicks of adjustment in the full range of motion. *As a starting point for tuning your blow-off threshold, turn the knob all the way clockwise until it stops, then back off one click.*



RLC

Changing Travel - FLOAT Forx

FOX FORX travel can be changed by rearranging the travel spacers as shown in the drawings below. After changing travel check the fork for proper operation before riding. If there is free movement in the fork or if it makes strange noises disassemble the fork and check for complete number and correct orientation of spacers.

- Step 1** - Remove the blue air cap from the top of the left fork leg. Let the air out of the fork. Refer to Pump Instructions for details about letting the air out with a pump. Remove left top cap with a 26mm socket 6-point socket wrench.
- Step 2** - Loosen the bottom nut 3-4 turns with a 10mm wrench. With a plastic mallet, gently tap the bottom of the shaft to disengage it from the lower leg. Allow oil to drain into a bucket. Remove the bottom nut and crush washer.
- Step 3** - Compress the fork as much as possible. The air piston will be visible about one inch below the top of the upper tube. Push the bottom of the shaft upwards to push the air piston out of the top of the upper tube. If necessary, use a small screwdriver to push the bottom of the shaft up through the hole in the bottom of the lower leg.
- Step 4** - Pull the air-shaft assembly from the fork. Refer to the drawings below and add or remove the appropriate spacer(s) to achieve the desired travel. NOTE: FLOAT FORX can be configured for 80 or 100mm of travel. Do not exceed 100mm of travel. Spacers snap on to the air shaft between the Spring Guide and the Topout Plate.
- Step 5** - Lubricate the o-ring on the air piston with FOX FLOAT Fluid and re-install the air shaft assembly into the upper tube. Push the shaft until it approaches the bottom hole of the fork. Do not push the shaft all the way through the bottom hole.
- Step 6** - Turn the fork upside down. Pour 30cc of FOX Suspension Fluid through the bottom hole.
- Step 7** - Push the air shaft assembly up until the shaft comes through the bottom hole. Install the crush washer and bottom nut. Torque to 50 in-lbs.
- Step 8** - Turn the fork right side up. Pour 5cc of FOX FLOAT Fluid on top of the air piston.
- Step 9** - Lubricate the o-ring on the air topcap with FOX FLOAT Fluid. Re-install the topcap and torque to 165 in-lbs.
- Step 10** - Air up the fork to the desired pressure and cycle it several times to check for proper operation. Re-install the blue air cap.

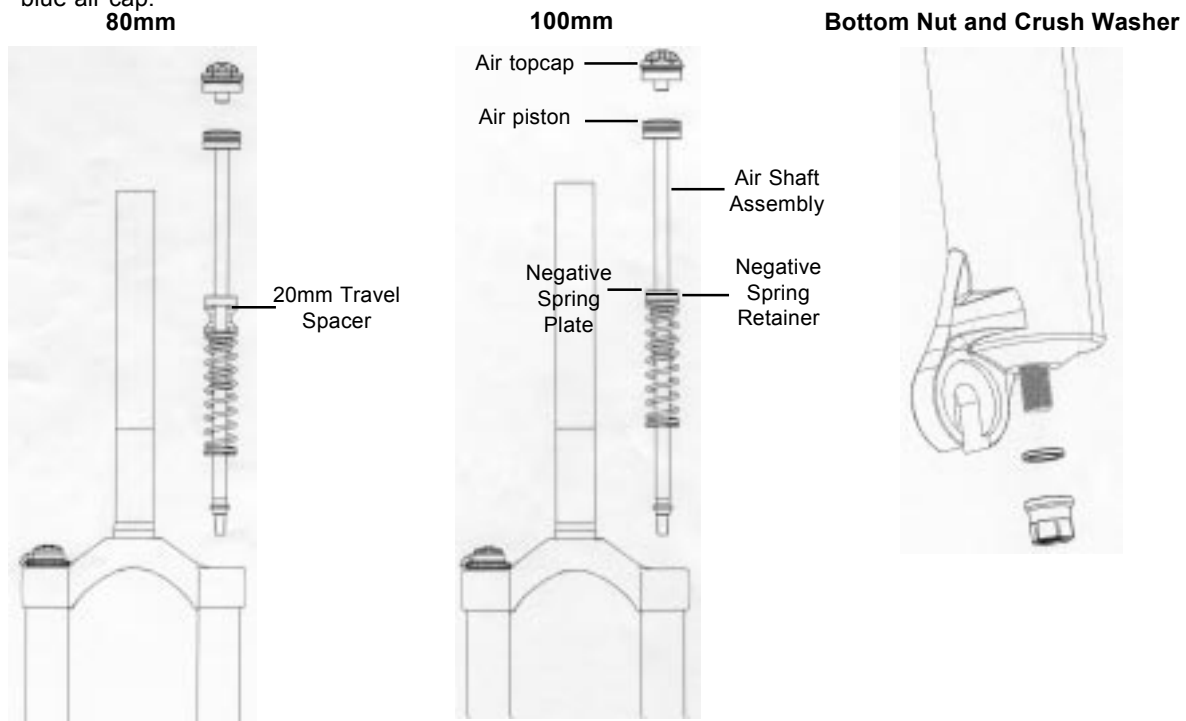

FLOAT Forx Travel Spacer Diagram

Changing Travel - Vanilla Forx

FOX FORX travel can be changed by rearranging the travel spacers as shown in the drawings below. After changing travel check the fork for proper operation before riding. If there is free movement in the fork or if it makes strange noises disassemble the fork and check for complete number and correct orientation of spacers.

The following tools and supplies will be needed: 26mm 6-sided socket, 10mm wrench, 2mm hex wrench, 1.5mm hex wrench, torque wrench, plastic faced hammer, small screw driver, drain pan, FOX Suspension Fluid.

Step 1 - Step 1a -Remove the left (spring side) top cap with a 26mm 6-sided socket.

Step 1b -On R models, simply remove the right (cartridge) side top cap with a 26mm 6-sided socket.

Step 1c -RL and RLC models require that the adjuster knobs be removed as shown in the drawing (see page 14). Remove the red rebound knob by firmly holding the red knob from turning and loosen screw with a 2mm hex wrench.

Step 1d -Remove the lock-out lever with a 1.5mm hex wrench by loosening the three set screws and carefully lifting the lever. *Do not remove the set screws. The 3 balls are held in place by grease. Do not lose the three balls in the lock-out lever.*

Step 1e -Remove the low-speed compression knob on RLC models. Below the low-speed compression knob is a detent ball and spring which sit in a counterbore in the topcap. Check that the ball is positioned in the hole by pressing on it with a small screwdriver and feeling for the force of the spring.

Step 1f - Loosen and unscrew the damper topcap with a 26mm 6-sided socket.

Step 2 - Compress fork slowly until the travel spacers are exposed on the damper side. Pull the damper topcap up until it stops. Snap on or off the correct length spacers to match the orientation shown in the **Travel Spacer Diagram (see page 14)**. If removing spacers from the cartridge, make sure to keep them in a safe place for future use.

Step 3 - Step 3a - Extend the fork by pulling down on the lower leg. Push down on the damper topcap and carefully thread into upper tube. Torque to 165 in/lbs.

Step 3b -Re-install adjuster knobs. On RLC models, install the low speed compression knob so that the groove on the bottom is positioned over the aluminum pin in the topcap.

Step 3c -On RL and RLC models, install the lockout lever onto the hex and rotate clockwise until it stops. It may take multiple rotations to seat the lockout shaft. Orient the lever so the lockout tab faces approximately the six o'clock position. While pressing the lockout lever down, lightly tighten the three set screws. Back each screw off 1/4 turn.

Step 3d -On all models, install red rebound knob so that the slot feature on the bottom is aligned with the flats on the center of the rebound shaft. Apply blue loctite to screw and tighten with 2mm hex wrench while holding red rebound knob from spinning.

Warning - Damper internals will be damaged if the rebound knob is not held turning while the screw is tightened.

Step 4 - Loosen the left (spring side) with a 10mm wrench or socket 3-4 full turns. Place a clean drain pan under the left leg and tap lightly with a plastic hammer on the nut to loosen the plunger from the lower leg. Unscrew and remove bottom nut and washer. Push up on the shaft and let oil drain.

Step 5 - Make sure all oil is drained from left side leg and right topcap is tight. Turn bike upside down and push out plunger shaft.

Step 6 - Looking at the **Travel Spacer Diagram**, add or remove spacers between the black negativespring guide and the aluminum coil insert. Spacers snap onto the shaft. Slide the black negative spring guide up against the spacers.

Step 7 - Reinstall the plunger shaft, spring and spacers into the left fork leg and install the crush washer and bottom nut. Torque the bottom nut to 50 in-lbs.

Step 8 - Pour in 30cc of new FOX Suspension Fluid or re-use oil from clean drain pan into the left upper tube.

Step 9 - Install left top cap and torque to 165 in-lbs.

Step 10 - Cycle the fork several times to check for proper operation before riding. If there is free movement in the fork or if it makes strange noises, disassemble fork to check for complete number and orientation of spacers.

Changing Travel - Vanilla Forx con't

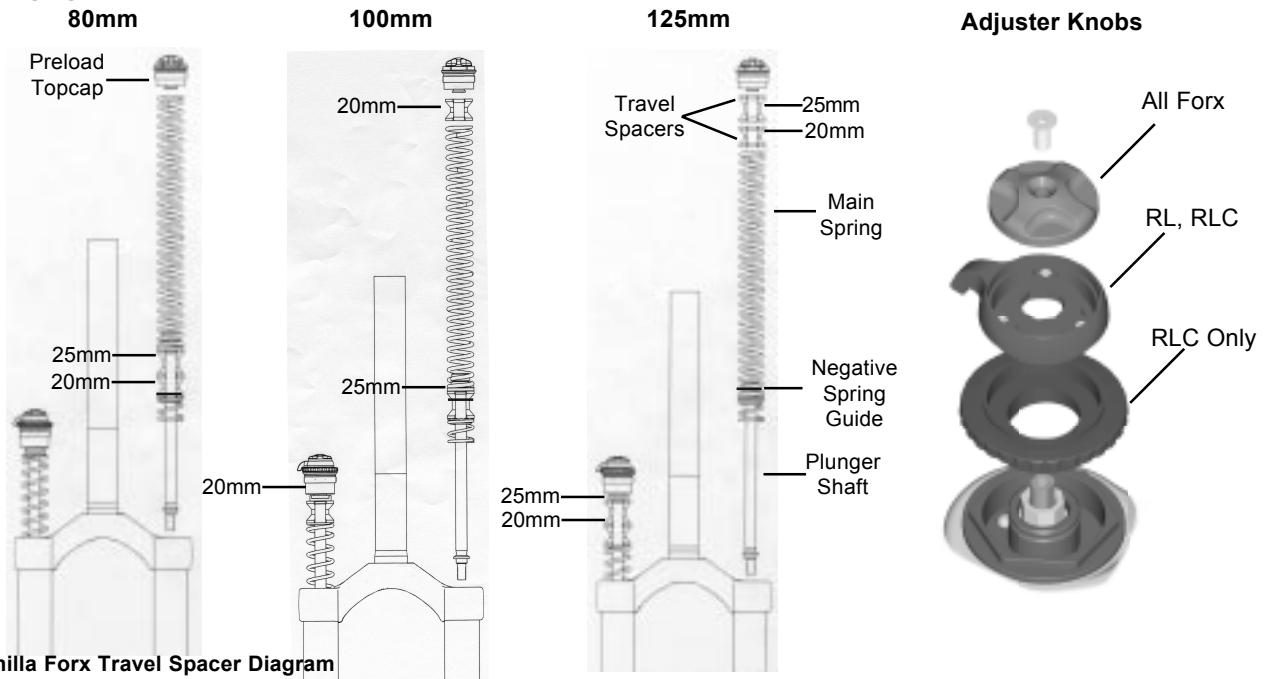

Vanilla Forx Travel Spacer Diagram

Bushings

Bushings should be checked annually for excessive wear. If fore and aft movement is detected between the upper tubes and lower legs, contact an Authorized FOX Racing Shox Service Center or FOX Racing Shox for further instructions. Grasp the lower legs at the drop outs (axle). Push the fork straight back towards the rear wheel. Then pull it towards you. There should not be any free movement or clicking sounds. Next grasp the fork near the upper tube/seal junction and try the same thing. Once again there should be no free movement. If any movement is noticed, refer to page 4 of this manual and contact FOX Racing Shox or an Authorized FOX Racing Shox Service Center.

Changing Oil

Vanilla Forks - Left Side

The left leg of FOX Vanilla Forx contain the parts shown on the **Vanilla Travel Spacer Diagram**.

The following tools and supplies will be needed: 26mm 6-sided socket, 10mm wrench, 2mm hex wrench, 1.5mm hex wrench, torque wrench, plastic faced hammer, small screw driver, drain pan, FOX Suspension Fluid.

Step 1 - Remove the Preload Topcap with a 26mm socket wrench. Remove all of the travel spacers from the top of the main spring.

Step 2 - Loosen the bottom nut 3-4 full turns with a 10mm wrench. Place a drain pan under the fork leg and then lightly tap the bottom nut with a plastic faced hammer to loosen the shaft from the lower leg. Remove bottom nut and crush washer. Push plunger shaft up into the lower leg with a small screwdriver and let the oil drain from the fork leg.

Step 3 - With all the oil drained, use the small screwdriver to carefully guide the plunger shaft back down through the hole in the bottom of the lower leg. Install the crush washer and bottom nut. Torque bottom nut to 50 in-lbs. Wipe excess oil from exterior of fork with a towel.

Step 4 - Pour 30cc of FOX Suspension Fluid into the top of the left upper tube.

Step 5 - Install travel spacers on top of main spring. Carefully thread Preload Topcap into upper tube and torque to 165 in-lbs.

FLOAT Forks - Left Side

The left leg of FOX FLOAT Forx contains the parts shown on page 12 in the FLOAT Forx Travel Spacer Diagram.

The following tools and supplies will be needed: 26mm 6-sided socket, 10mm wrench, 2mm hex wrench, 1.5mm hex wrench, torque wrench, plastic faced hammer, small screw driver, drain pan, FOX Suspension Fluid plus a FOX High Pressure Air Pump and FOX FLOAT Fluid.

Changing Oil con't

- Step 1** - Remove the blue air cap from the top of the left fork leg. Let the air out of the fork. Refer to Pump Instructions for details about letting the air out with a pump. Remove left top cap with a 26mm socket 6-point socket wrench.
- Step 2** - Loosen the bottom nut 3-4 turns with a 10mm wrench. With a plastic mallet, gently tap the bottom of the shaft to disengage it from the lower leg. Allow oil to drain into a bucket. Remove the bottom nut and crush washer.
- Step 3** - Compress the fork as much as possible. The air piston will be visible about one inch below the top of the upper tube. Push the bottom of the shaft upwards to push the air piston out of the top of the upper tube. If necessary, use a small screwdriver to push the bottom of the shaft up through the hole in the bottom of the lower leg.
- Step 4** - Pull the air-shaft assembly from the fork. Clean and dry assembly.
- Step 5** - Lubricate the o-ring on the air piston with FOX FLOAT Fluid and re-install the air shaft assembly into the upper tube. Push the shaft until it approaches the bottom hole of the fork. Do not push the shaft all the way through the bottom hole.
- Step 6** - Turn the fork upside down. Pour 30cc of fresh FOX Suspension Fluid through the bottom hole.
- Step 7** - Push the air shaft assembly up until the shaft comes through the bottom hole. Install the crush washer and bottom nut. Torque to 50 in-lbs.
- Step 8** - Turn the fork right side up. Pour 5cc of FOX FLOAT Fluid on top of the air piston.
- Step 9** - Lubricate the o-ring on the air topcap with FOX FLOAT Fluid. Re-install the topcap and torque to 165 in-lbs.
- Step 10** - Air up the fork to the desired pressure and cycle it several times to check for proper operation. Re-install the blue air cap.

FLOAT & Vanilla Forx - Right Side

The right leg of FOX FORX contains the damper. The damper is a precision component that controls the compression and rebound of your FOX FORX. If your cartridge ever loses oil, be sure to complete these 9 steps to ensure that you have the proper volume of oil in the damper. Use only FOX Suspension Fluid in your FOX FORX.

NOTE: Too much oil will cause hydraulic lock-out of the fork. This is a serious condition and could lead to loss of control and serious or fatal injury.

The following tools and supplies will be needed: 26mm 6-sided socket, 10mm wrench, 2mm hex wrench, 1.5mm hex wrench, torque wrench, plastic faced hammer, small screw driver, drain pan, FOX Suspension Fluid plus a FOX High Pressure Air Pump and FOX FLOAT Fluid.

- Step 1** - Step 1a -On R models, simply remove the right (damper) side top cap with a 26mm 6-sided socket.
Step 1b -RL and RLC models require that the adjuster knobs be removed as shown on page 14. Remove the red rebound knob by firmly holding the red knob from turning and loosen screw with a 2mm hex wrench.
Step 1c -Remove the lock-out lever with a 1.5mm hex wrench by loosening the three set screws and carefully lifting the lever. *Do not remove the set screws. There are 3 balls in the lockout lever. The 3 balls are held in place by grease. Do not lose the three balls in the lock-out lever.*
Step 1d -Remove the low-speed compression knob on RLC models. Below the low-speed compression knob is a detent ball and spring which sit in a counterbore in the topcap. Check that the ball is positioned in the hole by pressing on it with a small screwdriver and feeling for the force of the spring.
Step 1e -Loosen and unscrew the damper topcap with a 26mm 6-sided socket.
- Step 2** - On RLC models, remove the blue blow-off threshold knob with a 2mm hex key wrench.
- Step 3** - Loosen the right side bottom nut with a 10mm wrench or socket 3-4 full turns. Place a clean drain pan under the right leg and tap lightly with a plastic hammer on the nut to loosen the damper from the lower leg. Unscrew and remove bottom nut and washer. Push up on the shaft and let the oil drain.

Changing Oil con't

Step 4 - Carefully pull the damper from the fork. It will still contain oil.

Step 5 - Place the damper upright in a deep bucket and carefully cycle the shaft up and down several times to pump out the remaining oil. Gently shake the damper to check whether it is empty.

Step 6 - When the damper is empty, pull it to its maximum length and install it into the fork. Install the crush washer and bottom nut and torque to 50 in-lbs.

Step 7 - Measure 160cc of fresh FOX Suspension Fluid and pour it into the right fork leg. Add it slowly to avoid overflowing and spillage.

Step 8 - Push down on the damper topcap and thread it carefully into the upper tube. Torque to 165 in-lbs.

Step 9 - Step 9a -Re-install adjuster knobs. On RLC models, install the low speed compression knob so that the groove on the bottom is positioned over the aluminum pin in the topcap.

Step 9b -On RL and RLC models, install the lockout lever onto the hex and rotate clockwise until it stops. It may take multiple rotations to seat the lockout shaft. Orient the lever so the lockout tab faces approximately the six o'clock position. While pressing the lockout lever down, lightly tighten the three set screws. Back each screw off 1/4 turn.

Step 9c -On all models, install red rebound knob so that the slot feature on the bottom is aligned with the flats on the center of the rebound shaft. Apply blue loctite to screw and tighten with 2mm hex wrench while holding red rebound knob from spinning.

Warning - Damper internals will be damaged if the rebound knob is not held turning while the screw is tightened.

Step 10 - Cycle the fork several times and run the adjusters through their full ranges of adjustment. You should feel damper fill with oil after several cycles. Adjust all damper settings to your preferences and head out for a nice ride.

Seals and Foam Rings

FOX FORX feature a sealing system designed to keep your fork moving smoothly in all conditions. There are two parts to the system - the fork seal and the foam ring. The fork seal features a proprietary scraper lip geometry that keeps dirt out and oil in the fork. The foam ring sits just below the fork seal. It is saturated with oil and in turn applies oil to the upper tube as it passes by. This keeps the fork moving up and down smoothly. While FOX FORX are designed to require minimal maintenance, periodic inspection and cleaning of the fork sealing system is recommended.

Step 1 - Around the perimeter of the fork seals are small notches. Use a small flat blade screw driver in these slots to gently pry the seal from the lower legs of the fork. Once loose, raise them all the way up to the crown on the upper tubes.

Step 2 - Wrap a clean rag around the junction of the upper tubes and the lower legs. This will keep dirt out while the seals are being cleaned.

Step 3 - Use a rag to wipe around the outside diameter of the seal. Wipe until clean.

Step 4 - Remove the rags and check the foam rings which will be visible just inside the lower legs. They should be soaked with oil and should not contain any dirt or debris. If the foam rings are dry, use a few cc's of FOX Suspension Fluid to saturate them.

Step 5 - Wipe the upper tubes and slide the seals down into the lower legs. Carefully press the seals into place. A thin flat bladed screw driver can be used to press in between the upper tube and the fork brace. It is recommended that the blade of the screw driver be covered with tape or a rag to prevent damage to the seal. Inspect that seal is firmly seated against top surface of the lower leg.

Step 6 - Wipe off any excess oil and cycle the fork a few times to check for proper operation.