

Headset Setup and Charging

- Adjusting headset for your comfort
- Charging your headset
- Turning your headset on

4
5
5

Bluetooth Hub Setup and Use (for Desk Phone)

- Connecting Bluetooth Hub with desk phone and power supply
- Making a test call on your desk phone to adjust settings
- Making and ending a call via desk phone
- Answering an incoming call to desk phone

6
7
9
11

Mobile Phone Setup and Use

- Pairing headset to mobile phone
- Making and ending a call from mobile phone
- Using Voice Dial
- Answering an incoming call to mobile phone

12
13
14
14

Quick Reference

- Operating the Answer/End button
- What the lights mean

15
16

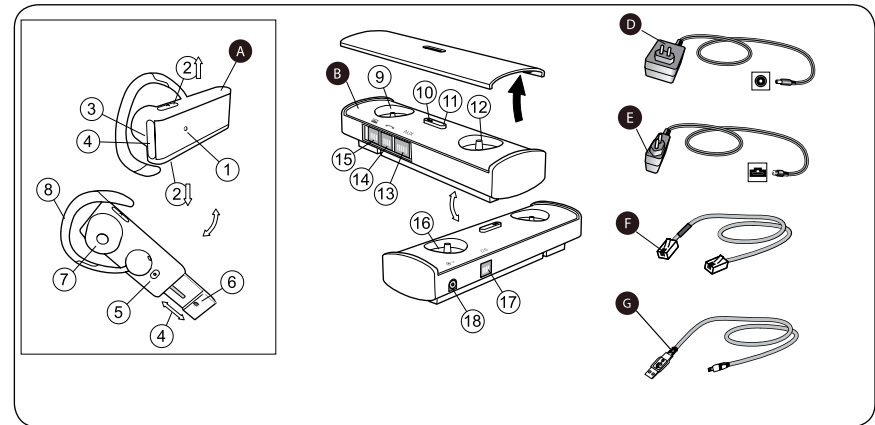

A. Jabra BT5010 headset

1. Light indicator (LED)
2. Volume controls
3. Charging socket
4. Answer/End button
5. On/Off + pairing button
6. Microphone
7. Speaker
8. Earhook

B. Jabra Bluetooth Hub

9. Dial Tone Switch
10. Light indicator (LED)
11. Pairing button
12. Microphone volume control
13. AUX socket
14. Handset socket
15. Desk phone socket
16. Reset button
17. Desk stand socket (not for use with Jabra BT5010 headset)
18. Power supply socket

- C.** Desk stand
- D.** Bluetooth Hub power supply
- E.** Headset power supply
- F.** Desk phone-Bluetooth Hub connection cord
- G.** USB cable

Before you begin setup, be sure all parts have been above 32°F/0°C for at least 30 minutes.

Adjusting headset for your comfort

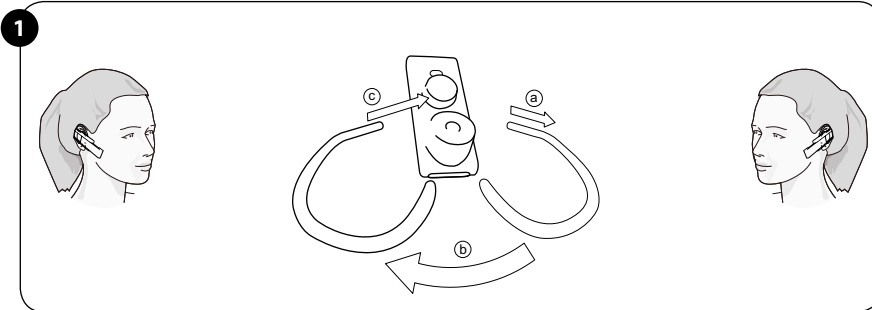

Headset is preset for use on right ear. Switch if necessary.

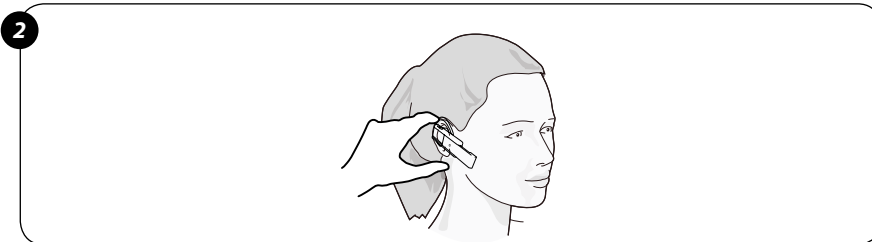

Bend to fit.

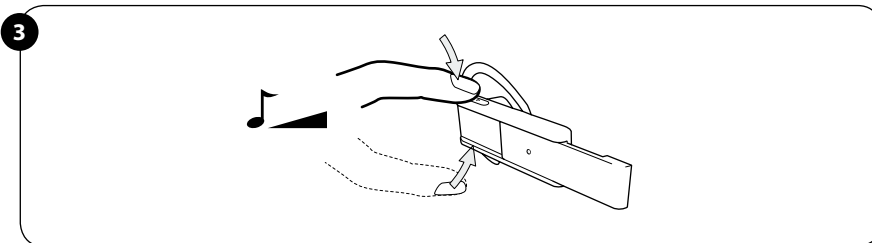

During a call adjust speaker volume (how others sound to you) on headset.

Charging your headset

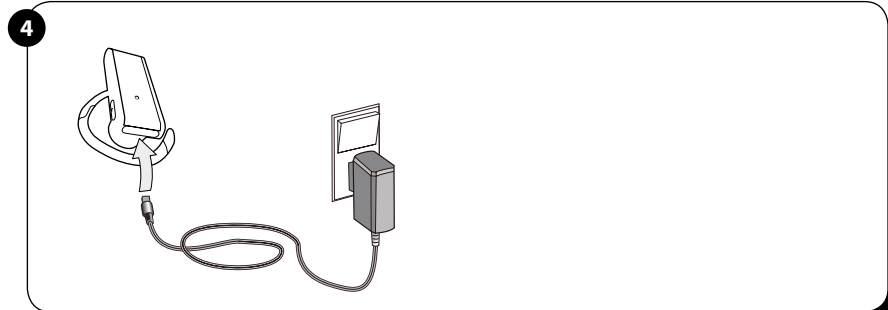

Charge via PC or Charge directly (handy for travel).

⚠ Important: Make sure your headset is inactive while charging.

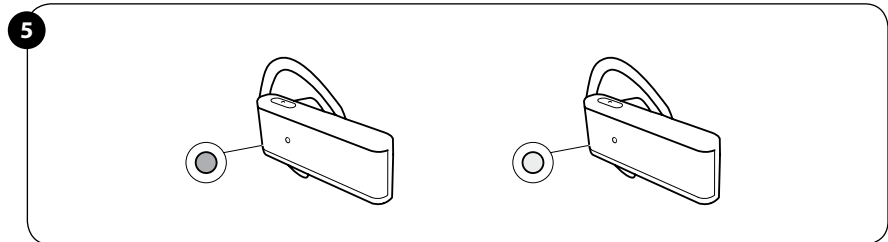

Red = charging. Green = fully charged (approximately 2 hrs.).

Turning your headset on

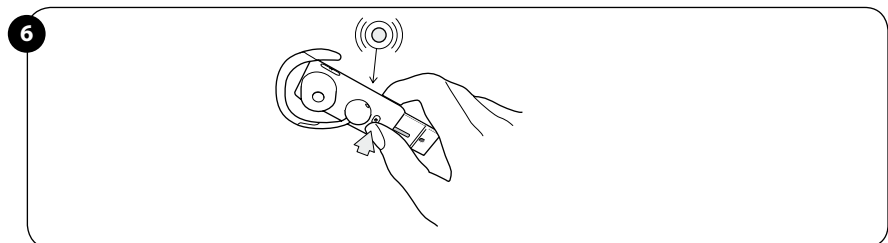

Press Headset on/off/pairing button for 1 sec. Blue flash.

Bluetooth Hub Setup and Use (for Desk Phone)

Connecting Bluetooth Hub with desk phone and power supply

- If you are using a GN 1000 (remote handset lifter) or an electronic hook switch lifter, please refer to the user manual on the supplied CD-ROM for instructions.
- If your desk phone has a headset port, see instructions inset.

For desk phones without headset port

1 Disconnect handset from desk phone.

2 Connect handset to Bluetooth Hub.

3 Connect desk phone with Bluetooth Hub using supplied connection cord (F).

4 Connect power supply to Bluetooth Hub.

For desk phones with headset port

1 Connect desk phone with Bluetooth Hub using supplied connection cord (F).

2 Connect power supply to Bluetooth Hub.

Making a test call on your desk phone to adjust settings

If your desk phone has an electronic hookswitch lifter, or you are using a GN 1000 (remote handset lifter), please refer to the User Manual on the supplied CD-ROM for instructions.

1 Place headset on ear.

2 Tap headset Answer/End button.

3 Lift desk phone handset.

4 Listen for dial tone in headset.
To be continued in the next page.

For desk phones with headset port

3 Press the appropriate desk phone button to establish a clear dial tone.

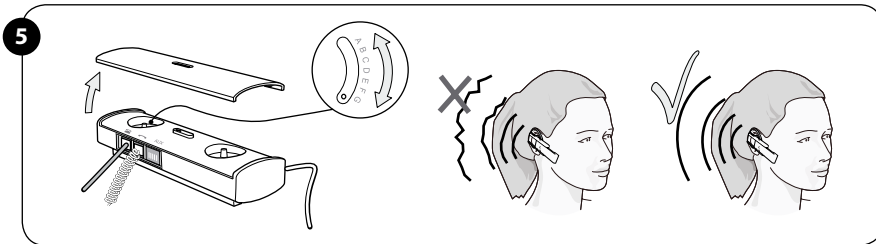

5 If dial tone is missing or unclear, slowly slide the Dial Tone Switch from A – G on the Bluetooth Hub. Dial Tone Switch is preset to setting A (most commonly used).

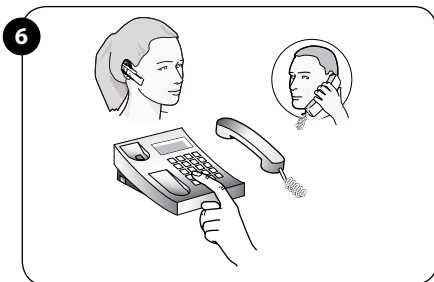

6 Dial a friend to test settings.

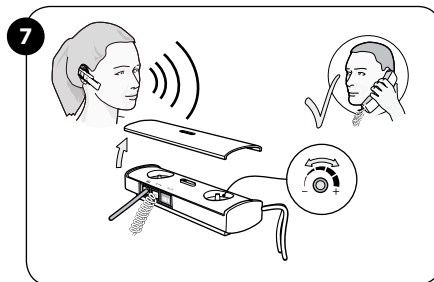

7 Adjust microphone volume (how your voice sounds to others) via Bluetooth Hub.

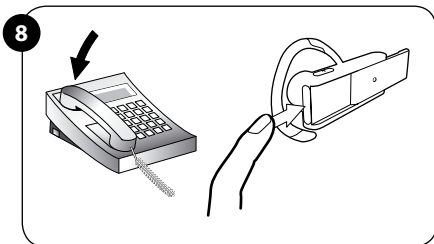

8 To end call, replace desk phone handset AND tap headset Answer/End button.

 **For desk phones with headset port**

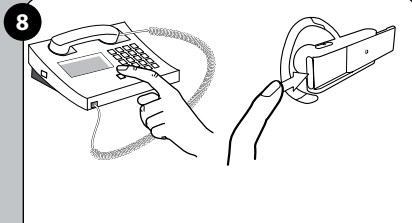

8 Press the appropriate button on desk phone AND tap headset Answer/End button.

Making and ending a call via desk phone

If your desk phone has an electronic hookswitch lifter, or you are using a GN 1000 (remote handset lifter), please refer to the User Manual on the CD-ROM for instructions.

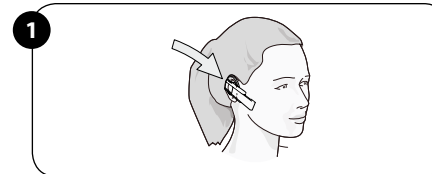

1 Place headset on ear.

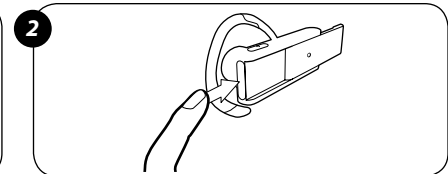

2 Tap headset Answer/End button.

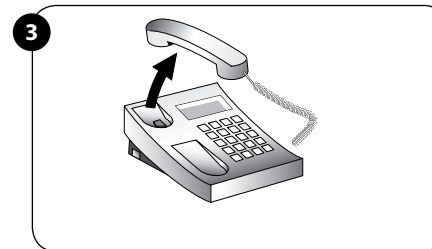

3 Lift desk phone handset.

 **For desk phones with headset port**



3 Press the appropriate desk phone button to establish a clear dial tone.

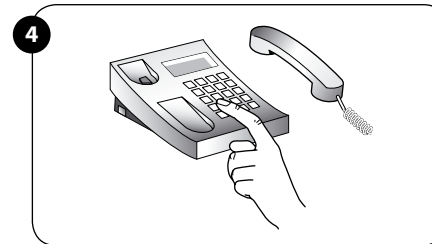

4 Dial number.

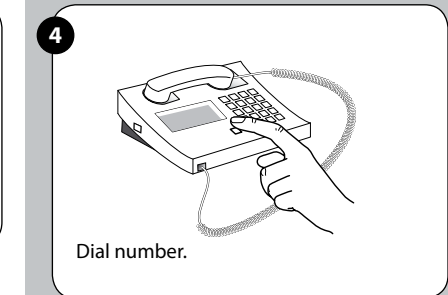

4 Dial number.

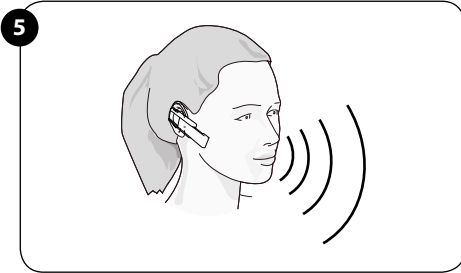

5 Begin talking.

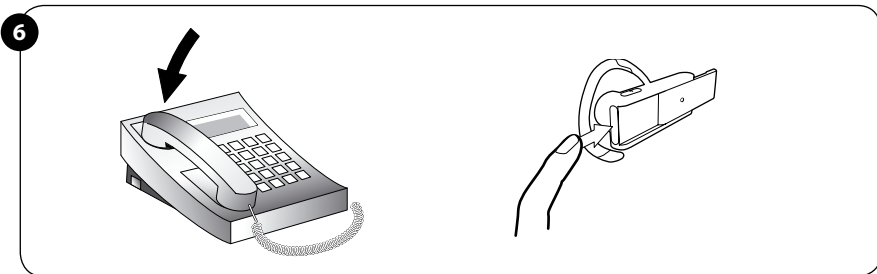

6 To end call, replace desk phone handset AND tap headset Answer/End button.

 **For desk phones with headset port**

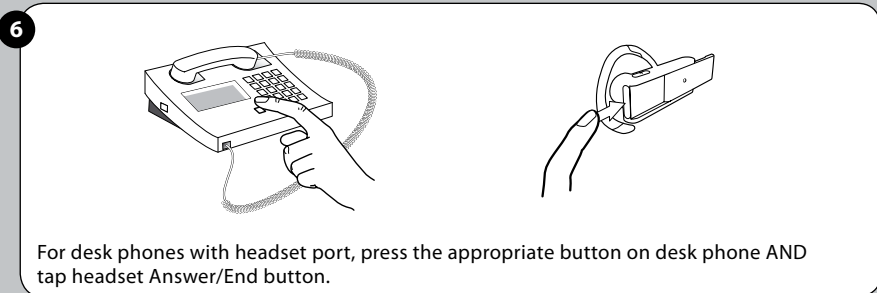

6 For desk phones with headset port, press the appropriate button on desk phone AND tap headset Answer/End button.

Answering an incoming call to desk phone

If your desk phone has an electronic hookswitch lifter, or you are using a GN 1000 (remote handset lifter), please refer to the User Manual on the CD-ROM for instructions.

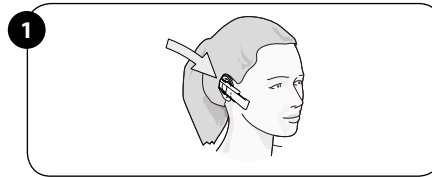

1 Place headset on ear.

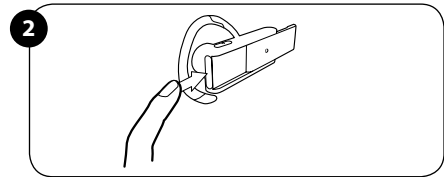

2 Tap headset Answer/End button.

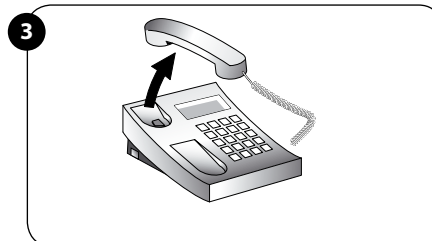

3 Lift desk phone handset.

 **For desk phones with headset port**



3 Press the appropriate desk phone button to establish a clear dial tone.

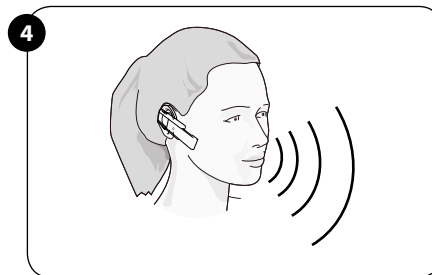

4 Begin talking.

Pairing headset to mobile phone (establishes Bluetooth connection)

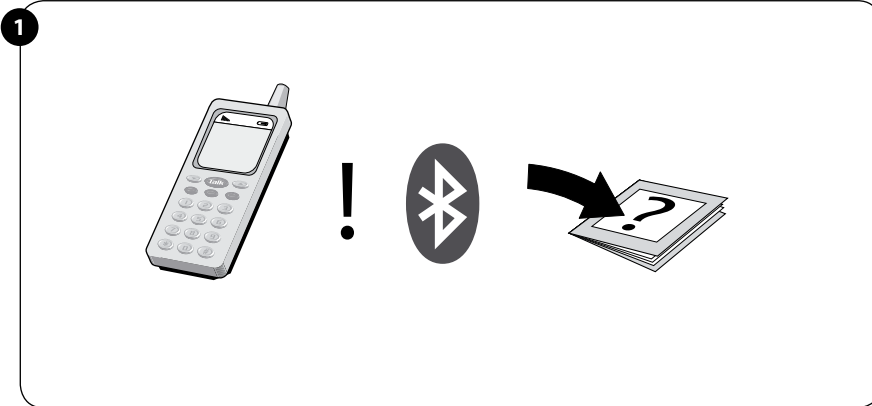

See your mobile phone User Guide for Bluetooth pairing instructions.

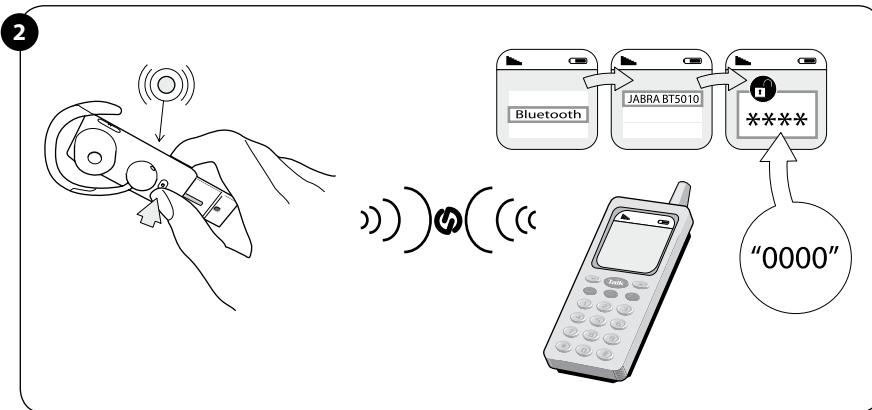

Press headset pairing button for 1 sec.
Blue light indicates open for pairing (5 minutes).

Making and ending a call from mobile phone



Place headset on ear. Dial number on mobile phone and tap Talk/Yes or similar.



Begin talking. To end call, press End/No or similar on mobile phone OR tap headset Answer/End button.

Using Voice Dial (if your mobile phone supports this feature)

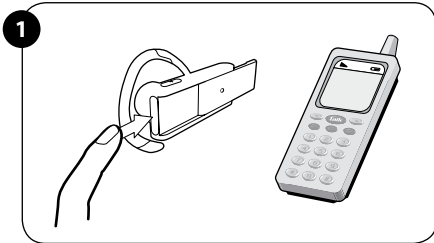

1 Press headset Answer/End button for 1 sec.

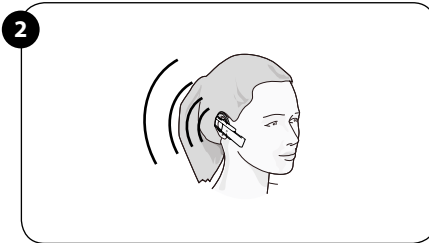

2 Hear voice dial signal. (Mobile phone dependent)

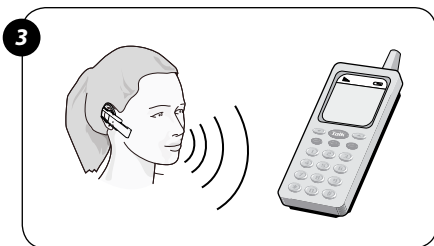

3 Give voice dial command.

Answering an incoming call to mobile phone

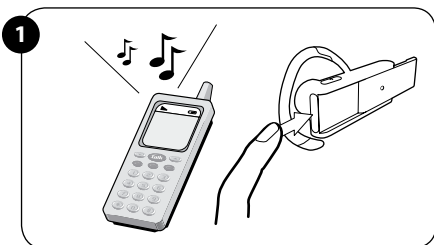

1 Tap headset Answer/End button.

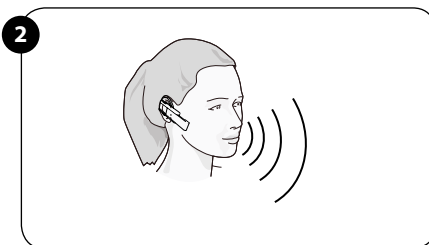

2 Begin talking.

Operating the Answer/End button

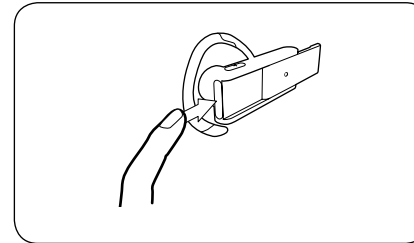

How to...	Headset Answer/End button action
Make call via desk phone	Tap
Make call via mobile phone Voice Dial*	Press for 1 sec
Redial last outgoing number* (from mobile phone)	Double tap
Answer all calls	Tap
End all calls	Tap
Reject a call (to your mobile phone)	Press for 1 sec
Put a call on hold*	Press for 1 sec
Switch between two active calls*	Press for 1 sec
End active call when another is on hold*	Tap

* If the mobile phone supports this feature

What the lights mean

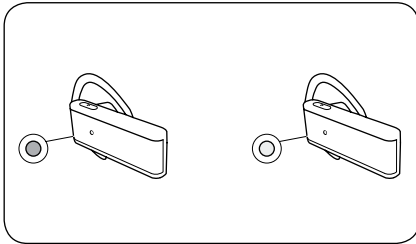

■ Red ■ Blue ■ Green

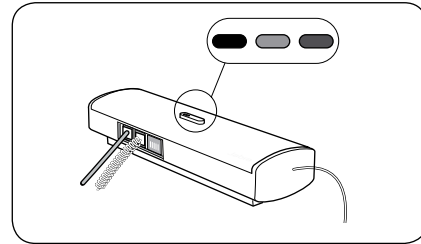

● Red ● Blue ● Green

Headset	
Green steady	Charge complete
Blue slow flash	Headset on
Blue fast flash	Call in progress
Blue steady	Headset in pairing mode
Red flash	Low battery
Red steady	Charge in progress

Bluetooth Hub	
Green steady	Bluetooth Hub on
Blue steady	Pairing in progress
Blue flash 10 times	Pairing successful
Red flash	Bluetooth Hub needs to be reset
Red steady	Reset in progress

Range:	Up to 10 meters/33 feet in line of sight
Talk time:	Up to 10 hours
Standby time:	Up to 300 hours
Charge time:	Up to 2 hours