

!WARNING!

H2O Audio stands behind our products.

Failure to follow our instructions could destroy your iPod and will void the Warranty. If you have any concerns, or experience any difficulties with your H2O Audio product, we are here to help you, so please contact us directly. We can be reached at:

1.800.708.6080 or 858.623.0339

support@h2oaudio.com

www.h2oaudio.com



**Please take a moment and visit
www.h2oaudio.com**

For updated Instruction Manuals,
Product Registration and to
complete your warranty.



iSH2

Waterproof Headset for the shuffle (2nd Gen)
Printed Instructions



H2O Audio cases are designed for specific Apple iPod models, which vary by generation and storage size. You must ensure the correct housing or case is purchased for your specific iPod model.

Before using this system, please be sure to read, understand, and follow the instruction of this manual.

2. iSH2 Features

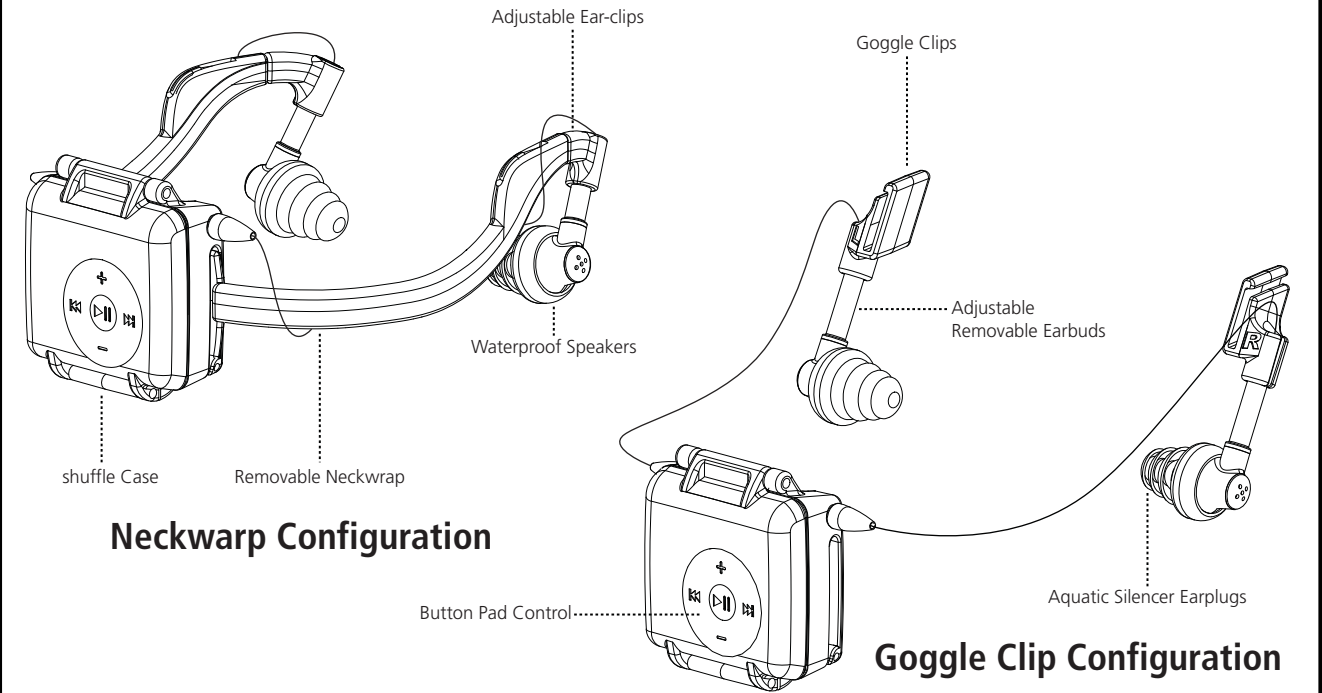

3. Introduction

The H2O Audio iSH2 Headset allows for an all-in-one waterproof solution (up to 10ft. / 3m) for the iPod shuffle (2nd Gen). Allowing you to listen to digital audio during active watersports, like swimming. The **Shuffle Case** allows for functional control of the player while in the water with the **Button Pad Control**. **NOTE:** The Case has no access to the Shuffle Switch or On / Off Switch on the iPod shuffle.

The headset includes **Waterproof Speakers**, made for complete submersion up to 10ft.(3m) and designed with **Removable Earbuds** which can be used with the included **Goggle Clips** to stay secure when wearing swim goggles.

Note: The iPod shuffle (2nd Gen) is NOT waterproof without the iSH2 Headset and is NOT covered under the product warranty. Any attempt to use the iSH2 Headset with an audio player other than the Apple iPod shuffle (2nd Gen) will void the warranty.

CAUTION: The earbuds insert directly into the ear, and are not to be used during SCUBA diving. Prolonged exposure to pressures at depths beyond 10ft.(3m) may result in permanent hearing loss. Discontinue use at the first sign of pain or discomfort.

4. Audio / Leak Test

Before using the iSH2 Headset it is recommended you perform an Audio Test.

1. Install the shuffle player into the **Shuffle Case** and verify that audio is audible through both speakers. If speakers are working remove the shuffle player and perform the leak test.
2. If your earbuds are operating at very low audio levels, it is possible that a vacuum has formed in the speaker chamber due to exposure to low pressure, such as in air travel.
3. Playing the headset at 90% volume for an hour typically solves this problem. If not, please contact H2O Audio Customer Support.

Before using the iSH2 Headset it is highly recommended to perform a Leak Test. **DO NOT INSTALL THE iPod shuffle 2nd Gen INSIDE THE CASE FOR THE LEAK TEST**

1. Open the case (Section 5), and verify the seal area is clean and free of debris or damage. Place a piece of tissue paper completely in the case before closing. (Ensure tissue does not interfere with the Seal of the Shuffle Case)
2. Immerse the headset, (without the iPod shuffle 2nd Gen) in water and soak for 30 min.
3. Manipulate the Button Control Pad during submersion.
4. Remove from the water, dry the exterior.
5. Open the housing and ensure there is no water in the case.
In the event of an unsuccessful Leak Test contact H2O Audio Customer Support immediately.

5. Installing the shuffle into the Shuffle Case

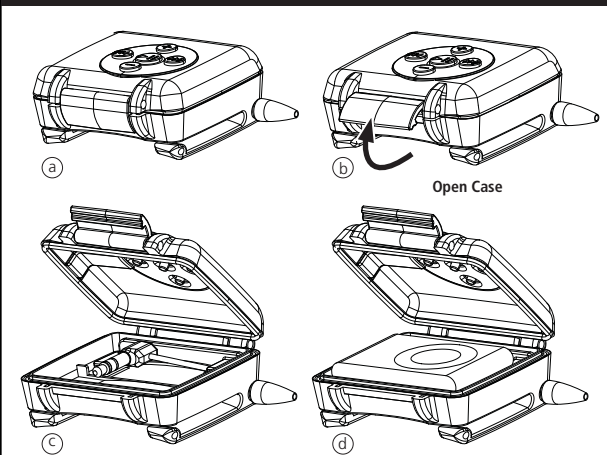

Plug audio jack into the shuffle player, place shuffle into case and ensure the control pad and the Button Pad Control are aligned. Close case.

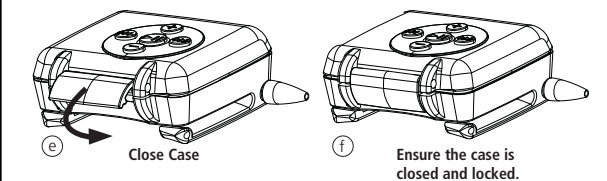

6. Important Seal Information

The most important feature of iSH2 Headset Case is the Seal that forms a waterproof barrier between the base and lid of the case. The **Seal is not removable** and should never come out of alignment. If the Seal shows any signs of wear or is coming out of alignment it is extremely important that you contact H2O Audio Customer Service immediately. It is up to you to check that the Seal is not damaged or out of alignment every time you install your iPod shuffle (2nd Gen) in the case. If the Seal is dirty, or damaged in any way it will compromise the integrity of the case and should not be used.

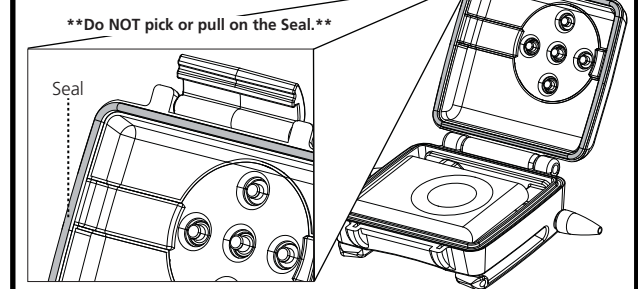

7. Button Pad Control

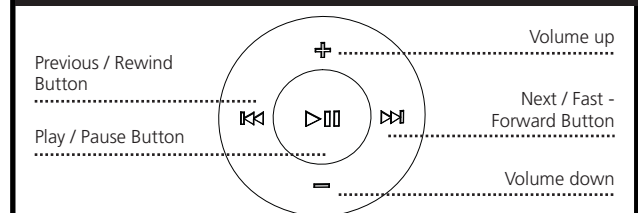

8. Creating a Custom Fit

The main adjustments in the headset are made in the **Ear-Clip** portion of the headphones.

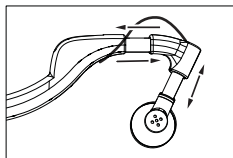

1. The neckband features adjustable **Ear-Clips** that can be extended for larger sizes, and retracted for smaller sizes. The earbud can also be moved up and down to create a comfortable fit directly into the ear canal.

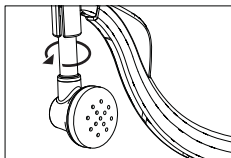

2. The speaker arm rotates within the **Ear-Clip**, allowing you to channel the audio output directly into the ear-canal.

9. Wearing the iSH2 Headset

The iSH2 Headset features a **Removable Neckwrap** with a 'behind-the-head' design that provides a secure and comfortable fit during most sporting activities. Follow these simple steps to put the headset on.

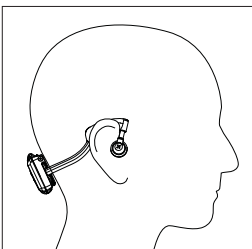

- 1.** With the shuffle player installed in the case bring the headset behind your head, and spread the neckwrap apart as you position the Ear-Clips by your ears.
- 2.** The Ear-Clips are designed to fit over the top of the ears, with the speaker arm angling into the ear canal from the top / front of the ear, as shown to the left.
- 3.** The Ear-Clips and Speaker arm can be adjusted for a custom fit, see Section 8.

13. FAQ's

1. The sound quality cuts in / out from my headphones, how can I fix or replace them?

Make sure that the audio jack inside the Shuffle Case is plugged in all the way for a complete connection. If problem still continues please contact H2O Audio Customer Support.

2. The sound quality seems muffled, what can I do to fix this problem?

- 1.** Purchase some wax earplugs (they cost about \$0.99) from your local drug store.
- 2.** Rip a piece of the wax and roll it into a cylinder long enough to go around the circumference of the largest barb of the earplug.
- 3.** Wrap the cylinder of wax around the largest barb of the earplug. This creates a custom mold to your ear and will help prevent water from entering the ear and muffling the sound.

3. The Neckwrap is uncomfortable and moves around when swimming, what can I do?

We recommended removing the Neckwrap and using the Goggle Clips. Please refer to Section 10.

NOTE: For more FAQ's please visit www.h2oaudio.com

14. Contact Us

Customer Support is available Monday to Friday 9AM to 5PM PST.

h2oaudio.com
P. 800.708.6080 or 858.623.0339
F. 858.225.0815
E. support@h2oaudio.com

Copyright Notice:
This owner's manual is copyrighted, all rights reserved. It may not, in whole or in part, be copied, photocopied, reproduced, translated, or formed into any electronic format without prior consent in writing. H2O Audio is a registered trademark of Diver Entertainment Systems, Inc. Apple and iPod are registered trademarks of Apple Computer Inc. Patents 6396769, 6614722, 6954405 Others Pending.

10. Removing Earbuds and using Goggle Clips

In some situations, the Neckwrap is not desired, such as under a swim cap. For these situations, we have designed **Goggle Clips** that hold the **Removable Earbuds** in place using the goggle strap. To remove the Earbuds and use the **Goggle Clips**, perform the following steps:

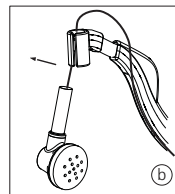
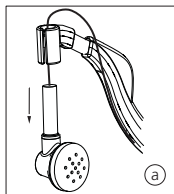

- 1.** Pull the earbud straight down through the end of the **Ear-Clip**. (a)
- 2.** Pull the wire through the opening on the end of the **Ear-Clip**. (b)
- 3.** Repeat Steps 1 and 2 for the other side.

4. Remove the wire from the track of the neckwrap.

5. Remove the **Shuffle Case** from the back of the neckwrap. (c) At this point the neckwrap is removed, and is recommend you store it out of the sun.

6. Slide the wire through the opening of the **Goggle Clip** and push the earbud up through the bottom of the **Goggle Clip**. Repeat for the other side. (d)

7. Attach the **Shuffle Case** and **Goggle Clips** to the strap of the goggles as shown. (e)

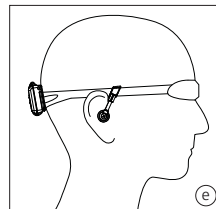
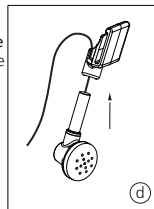
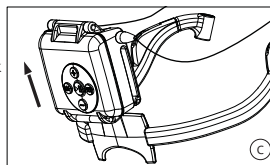

11. Fitting the Earplugs

The H2O Audio iSH2 Headset includes removable **Aquatic Silencer Earplugs** designed to keep water from freely flowing in and out of the ear canal during use. For the best performance, the earplug needs to seal completely with the walls of the inner ear. These earplugs are very pliable, and can fit in most people's ears. Typically rotating the speaker so it plays into the ear, will help to clarify sound during watersports.

Installing the Earplugs:

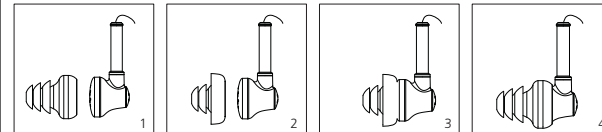

- 1.** Align earplug with the speaker.
- 2.** Invert the wide opening of the earplug.
- 3.** Place the inverted earplug directly against the speaker shield.
- 4.** Wrap the earplug around the speaker until it holds securely.

The earplugs are designed to fit comfortably in most ears. However you may have to work the ear plugs back and forth in the ear until a good seal is created. You will feel some suction don't worry this is normal.

NOTE: Make sure the earplugs are securely in place before proceeding with use.

12. Important Safety Information

CAUTION: Using earplugs limits your ability to hear noises around you, regardless of listening volume. Use with extreme caution.

CAUTION: Exercise caution and extreme safety when wearing headphones while surfing, wakeboarding, swimming, walking, jogging, or other activities.

CAUTION: Never wear headphones while operating any motorized vehicle, bicycle, or other machinery. It may create a hazard and is illegal in many areas.

15. General Use Notice

READ THIS MANUAL CAREFULLY. IF YOU HAVE ANY QUESTIONS PLEASE CONTACT H2O AUDIO CUSTOMER SUPPORT PRIOR TO USE.

IMPROPER USE OF THIS SYSTEM MAY CAUSE THE USER TO MAKE MISTAKES OR DECISIONS THAT MAY LEAD TO SERIOUS INJURY OR DEATH.

IMPORTANT WARNING AND DISCLOSURE:

THOSE USERS THAT ELECT TO UTILIZE THIS SYSTEM AT, OR NEAR, THE WATER'S SURFACE, MUST MAINTAIN SAFETY AWARENESS OF MOVING WATER CRAFTS.

ALWAYS MAKE SURE TO HAVE THE AUDIO PLAYER VOLUME TURNED TO ZERO AND THE SPEAKERS AWAY FROM THE EARS WHEN TURNING ON THE H2O AUDIO UNIT. IF THE VOLUME LEVEL IS NOT ZERO WHEN THE H2O AUDIO IS TURNED ON, IT MAY CAUSE EAR INJURY DUE TO A SUDDEN BURST OF VOLUME. THE VOLUME SHOULD BE SLOWLY INCREASED WITH AN AUDIO FILE PLAYING TO SET THE SPEAKER VOLUME TO COMFORTABLE OUTPUT LEVELS PRIOR TO POSITIONING THE SPEAKERS NEXT TO THE EARS.

IT CAN BE POTENTIALLY DANGEROUS TO PLAY YOUR HEADSETS WHILE ENGAGING IN ACTIVITIES THAT REQUIRE YOUR FULL ATTENTION. YOU SHOULD EXERCISE EXTREME CAUTION OR DISCONTINUE USE IN POTENTIALLY HAZARDOUS SITUATIONS. DO NOT USE THE HEADPHONES WHILE DRIVING, CYCLING, OR OPERATING ANY MOTORIZED VEHICLE. IT MAY CREATE A TRAFFIC HAZARD AND IS ILLEGAL IN SOME AREAS.

AVOID USING HEADPHONES AT HIGH VOLUME. HEARING EXPERTS ADVISE AGAINST CONTINUOUSLY LOUD AND EXTENDED PLAY. IF YOU EXPERIENCE RINGING IN YOUR EARS, REDUCE VOLUME OR DISCONTINUE USE.

THE MANUFACTURER DOES NOT WARRANT AND WILL NOT BE HELD RESPONSIBLE IN ANY WAY FOR DAMAGES TO THE iPod, OR LOSS OF DATA, INCLUDING LOSS OF DATA STORED IN THE iPod, RESULTING FROM AN EXCESSIVE IMPACT, THUNDER, OR AN EORED ON YOUR DEVICE.

16. Warranty Coverage

H2O Audio guarantees, to the original purchaser only, that the equipment purchased (EXCLUDING THE iPod) is free of defects in material and/or under normal recreational use for a period of ninety (90) days from date of consumer purchase from an Authorized Dealer; provided that proper care and maintenance have been performed as prescribed by the owner's guide included with the equipment. Should this product prove to be defective for any reason (other than those listed as limitations below) the product will be serviced or replaced at H2O Audio's sole discretion at no charge (excluding shipping and handling). This warranty shall be void if the registration is not completed and sent to H2O Audio Customer Services within 30 days of purchase. This warranty shall be void if the equipment has been tampered with by anyone not authorized to perform service. The warranty is non-transferable and extends to the original purchaser only and is valid only if the equipment was purchased from an authorized dealer. Warranty does not extend to cover damage from accident, abuse, tampering, lack of maintenance, theft, or loss. Service or modifications by anyone other than an Authorized H2O Audio agent will void the warranty. H2O Audio will not be responsible for recovery or replacement of the product in the event of loss or theft. H2O Audio, its Authorized International Distributors, and Authorized Dealers make no other warranties, either express or implied or orally, or in writing, with respect to any other warranty coverage except those expressly stated within the preceding sentences. H2O Audio will not be held responsible for any agreements orally or in writing with the exception of those expressly included in this warranty statement. The warranty registration card and the terms contained herein supersede all statements contained in any and all owner's guides, instruction cards, or other equipment literature or catalogs. In no event will H2O Audio, its Authorized International Distributors, and Authorized Dealers be held responsible or liable for any personal injuries resulting from the use of the covered equipment, or for any other damages, whether direct, indirect, incidental, or consequential; even if H2O Audio has been advised of such damages. Warranty does not extend to any damages that may occur to the iPod or loss of any data.

17. Returns

Prior to any return, a Return Authorization (RA) number must be obtained. To receive an RA number, go online to www.h2oaudio.com/returns.php and follow the simple instructions on how to return a product. Proof of purchase from an Authorized Dealer will be required. A copy of the original sales receipt and a copy of the owner's portion of the warranty card must accompany all correspondence regarding the equipment covered by this warranty agreement or in direct reference to this warranty.