

namco®



Operators Manual

1. SPECIFICATIONS

POWER SUPPLY :- 220/240volts AC

MONITOR :- Hantarex 28" Polo Colour Monitor with auto degauss.

DIMENSIONS :- 790(w) x 1200(d) x 2080(h)

WEIGHT :- 175kg.

- ACCESSORIES :-
- Keys: (Cash Door) 2
 - (Coin Door) 2
 - (Back Door)..... 2
 - IEC Mains Lead 1
 - Operators Manual 1
 - Monitor Manual 1

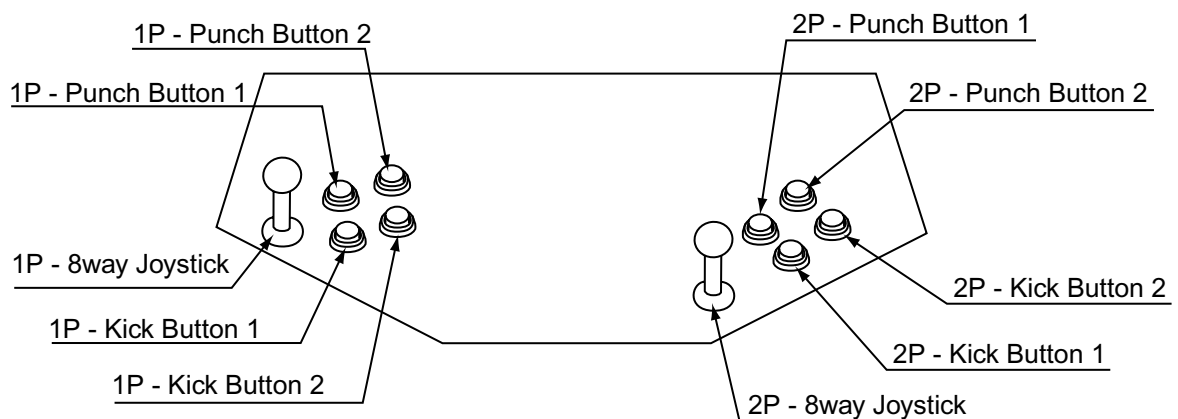

2. PRECAUTIONS

2-1 Cautions When Installing.

This game is designed for indoor use only. The game must not be installed outdoors or under the following conditions:-

- a. In areas directly exposed to sunlight, high humidity, direct water contact, dust, high heat or extreme cold.
- b. In locations that would present an obstacle in the case of an emergency, i.e. near fire equipment or emergency exits.
- c. On an unstable surface or subject to floor vibration.

2-2 Cautions when Handling.

- a. AC power must always be turned OFF, and the game disconnected, before replacing any parts or connecting/disconnecting connectors.
- b. When unplugging the game from an electrical outlet, always grasp the plug, not the mains lead.
- c. The machine must be earthed with a securely connected earthed plug.
- d. Care must be taken at all times to avoid electric shock when inspecting or adjusting the game.

2-3 Cautions when Transporting.

- a. Do not subject the game to physical shock when transporting or moving it.
- b. Always return the levellers to the UP position before moving the machine.
- c. Take care not to rope any moulded (plastic) parts when transporting.

2-4 Cautions when handling the PCB.

- a. Never test the PCB for continuity with a multimeter or similar device. The PCB contains sensitive devices which could be damaged or even destroyed by the internal voltage of such test equipment.
- b. Foreign matter or dust on the PCB may cause failure. Turn off the power and clean the PCB with a dry soft brush.
- c. When transporting the PCB ensure adequate packing protection to prevent damage.

3. ADJUSTMENTS

3-1 Turning on the Power

After installing the machine, turn on the power. The power switch is located above the mains inlet on the rear of the cabinet.

3-2 Switches for Adjustment

Open the coin door to find the switches for adjustments, located on the service bracket.

1. Service Switch

Press this switch to obtain game credits without incrementing the coin counter.

2. Test Switch

Slide this switch "ON" to enter test mode.

Test mode allows game testing and the changing of game settings.

[\(See "3-4 Test Mode" on page 5\)](#)

There are two DIP switches located on the PCB.

Switch 1 when set ON will enter the game into test mode. Always ensure this switch is set to OFF and use the test switch on the service bracket for testing the machine. Switch 2 when set ON will freeze the screen.

3-3 Volume Adjust

The volume control is located on the PCB. Turn the control to increase or decrease the volume.

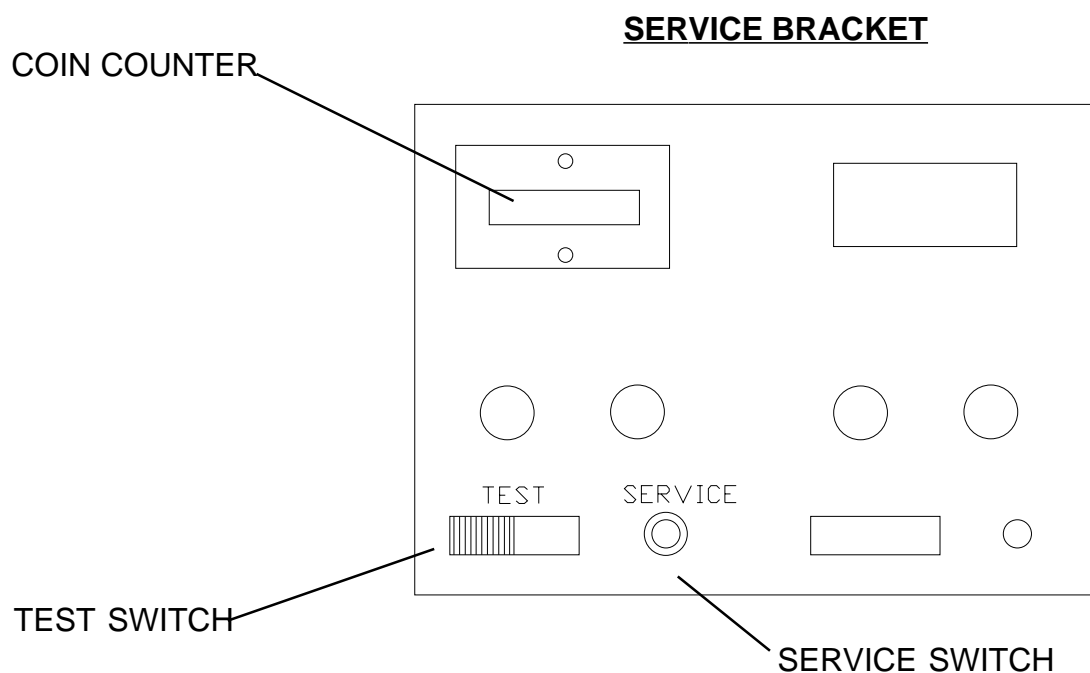

3-4 Test Mode

1. Open the coin door for access to the service bracket, then slide the test switch "ON". The "Test Menu Screen" will appear on the monitor display.
2. Operating the 1 Player joystick up or down will step through the items.
3. Pressing the 1 Player Punch button 1 switch will select an item.
4. Operating the 1 Player joystick up or down will change the settings.
5. Pressing the 1 player Punch button 1 switch will store the change.
6. Pressing the 1 Player button 2 switch will return the display to the Test Menu Screen.

The test switch must always be "OFF" during normal game mode.

SWITCH TEST	For testing switches
SOUND TEST	For testing the sound
COIN OPTIONS	For setting game pricing
GAME OPTIONS	For setting of difficulty etc.
UARTS TEST	Not Used
POLYGON TEST	For testing graphics
A.D.S	Not Used
COLOR TEST	For monitor set-up
CONVERGENCE TEST	For monitor set-up
RS-232C TEST	Not Used

Test Menu Screen

3-4-1 Switch Test

On entering the switch Test, the following screen appears on the monitor.

Operating the joysticks will cause the + to change to X for each of the eight positions.

When testing:

1P Punch 1 1P 0000 will change to 1P 1000
1P Kick 1 3P 0000 will change to 3P 1000
1P Kick 2 3P 0000 will change to 3P 2000
2P Punch 1 2P 0000 will change to 2P 1000
2P Punch 2 2P 0000 will change to 2P 2000
2P Kick 1 4P 0000 will change to 4P 1000
2P Kick 2 4P 0000 will change to 4P 2000

Pressing 1P Punch 2 will return the to Menu Screen

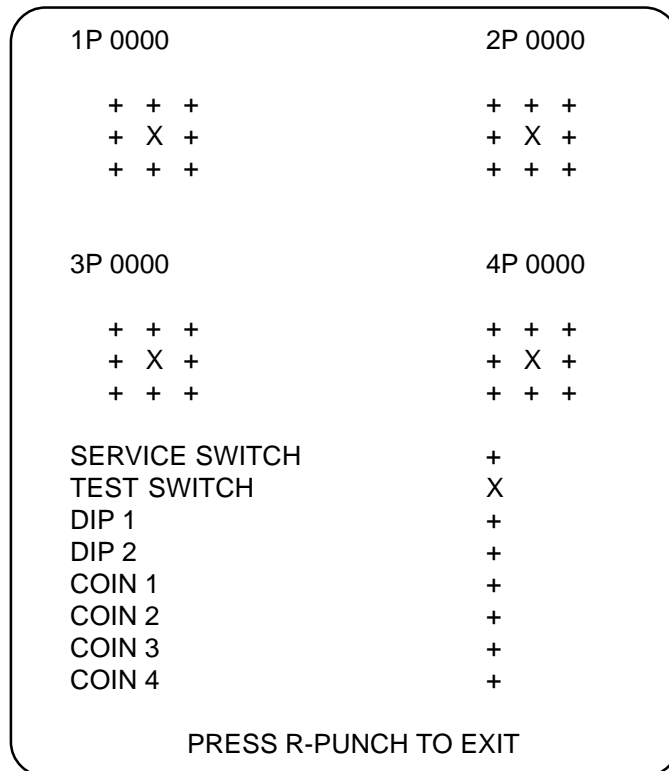

3-4-2 Sound Test

On entering the Sound Test, the following display will appear on the monitor.

Pushing the 1 player joystick to the right will make the number step up and pushing the joystick to the left will make the number step down.

Each number will produce a different sound when the 1 player Punch 1 button is pressed.

Song 001 will produce a tone first on the left speaker, then on the right speaker and then on both speakers together.



3-4-3 Coin Options

Note:- The price of play on this machine is set using the DIP switches on the credit board fixed to the coin mech. Ensure that the coin options on the screen are set as shown

GAME OPTIONS	
GAME COST -----	(1)
1 COIN 1 CREDIT	
DISCOUNT TO CONTINUE -----	(2)
NO	
COIN 1 MECH VALUE -----	(3)
1 COIN COUNT AS 1 COIN	
COIN 2 MECH VALUE -----	(4)
1 COIN COUNT AS 1 COIN	
COIN 3 MECH VALUE -----	(5)
1 COIN COUNT AS 1 COIN	
COIN 4 MECH VALUE -----	(6)
1 COIN COUNT AS 1 COIN	
BONUS FOR QUANTITY BUY-IN -----	(7)
NONE	
CREDIT MODE -----	(8)
COMMON	
COIN COUNTER -----	(9)
TYPE A: 1 COUNTER	
FREE PLAY -----	(10)
NO	

Coin Option Screen

3-4-4 Game Options

GAME OPTIONS	
DIFFICULTY LEVEL -----	(11)
MEDIUM	
FIGHT COUNT -----	(12)
2	
ROUND TIME -----	(13)
40sec.	
MUSIC IN ATTRACT -----	(14)
YES	
SPEAKER OUT -----	(15)
STEREO	
2P GAME WINS SHOWN BY -----	(16)
FRUIT	
CHARACTER CHANGE AT CONTINUE -----	(17)
NO	
HIT COLOUR -----	(18)
RED	

Game Option Screen

3-4-5 Factory Settings

ITEM	CONTENTS	FACTORY SET
(1) GAME COST	COIN PULSES REQUIRED FOR CREDIT ----- settable 1 - 9	1
(2) DISCOUNT	50% DISCOUNT FOR CONTINUE ----- YES / NO	NO
(3) COIN 1 MECH VALUE	NUMBER OF PULSES ON METER ----- settable 1 - 9	1
(4) COIN 2 MECH VALUE	NUMBER OF PULSES ON METER ----- settable 1 - 9	1
(5) & (6)	NOT USED	
(7) BONUS COIN	EXTRA COIN PULSE AT SPECIFIED COINS IN	NONE
(8) CREDIT MODE	COMMON (Credit common to player 1 & 2) / EACH ONE (Player 1 & 2 seperate)	COMMON
(9) COIN COUNTER	TYPE A (1 Coin Counter) / TYPE B (2 Coin Counters)	TYPE A
(10) FREE PLAY	YES / NO	NO
(11) DIFFICULTY LEVEL	EASY / MEDIUM / HARD / VERY HARD	MEDIUM
(12) FIGHT COUNT	Settable 1 - 5	2
(13) ROUND TIME	20 / 30 / 40 / 50 / 60 seconds	40sec
(14) MUSIC IN ATTRACT	YES / NO	YES
(15) SPEAKER OUT	STEREO / MONO	STEREO
(16) 2P GAME WINS SHOWN BY	FRUIT / NUMBER 1	FRUIT
(17) CHARACTER CHANGE	YES / NO	NO
(18) HIT COLOUR	RED / OTHERS	RED

4. PARTS

Decals & Plastics

DESCRIPTION	PART No.
Cabinet Decal LHS - Upper	40000054
Cabinet Decal LHS - Lower	40000055
Cabinet Decal RHS - Upper	40000056
Cabinet Decal RHS - Lower	40000059
Cabinet Decal LHS/RHS - Front	40000060
Cabinet Decal "NAMCO" LHS/RHS/Front	40000061
Character Decal	40000062
Play Panel Overlay	33000023
Header Box Vac-Form	45000222
Top Flash Acrylic	30000035

Cabinet

DESCRIPTION	PART No.
Monitor 28" Hantarex c/w Remote	84000012
Front Glass - Bronze	31000022
Interlock Switch	60000006
Interlock Switch Cover	39000028
M16 Adjustable Foot	88300079
Switch Mode Power supply	83000040
Speaker 4½" 20w (with shield can)	62000006
Schaffner Mains In Assy	66000016
Schaffner Boot	66000017
Fuse 5amp 20mm Slo-Blo	63500600
18" 15w Fluorescent Tube	64500009
Choke 240v 15w	63300000
Starter	63000000
Service Switch - SPNO	60000059
Test Switch - DPCO	60000023
3.5 - 6v Panel Meter	65000002
Joystick 8way Brent Fast Action Type	61000017
Push Button - Yellow	60200266
Push Button - Green	60200267
Push Button - Red	60200264
Push Button - Blue	60200263
Push Button - White	60200262

5. SCHEMATIC

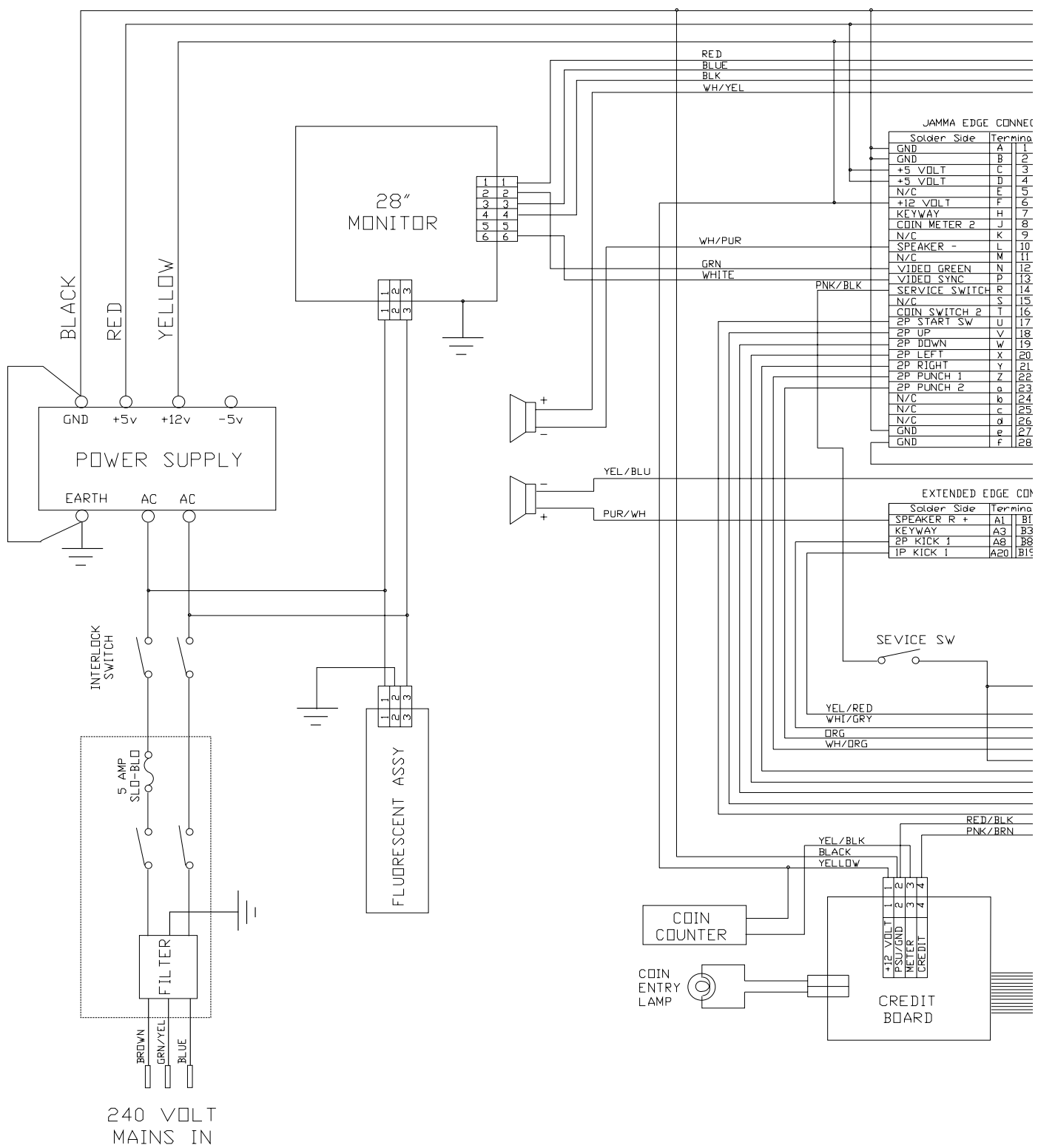

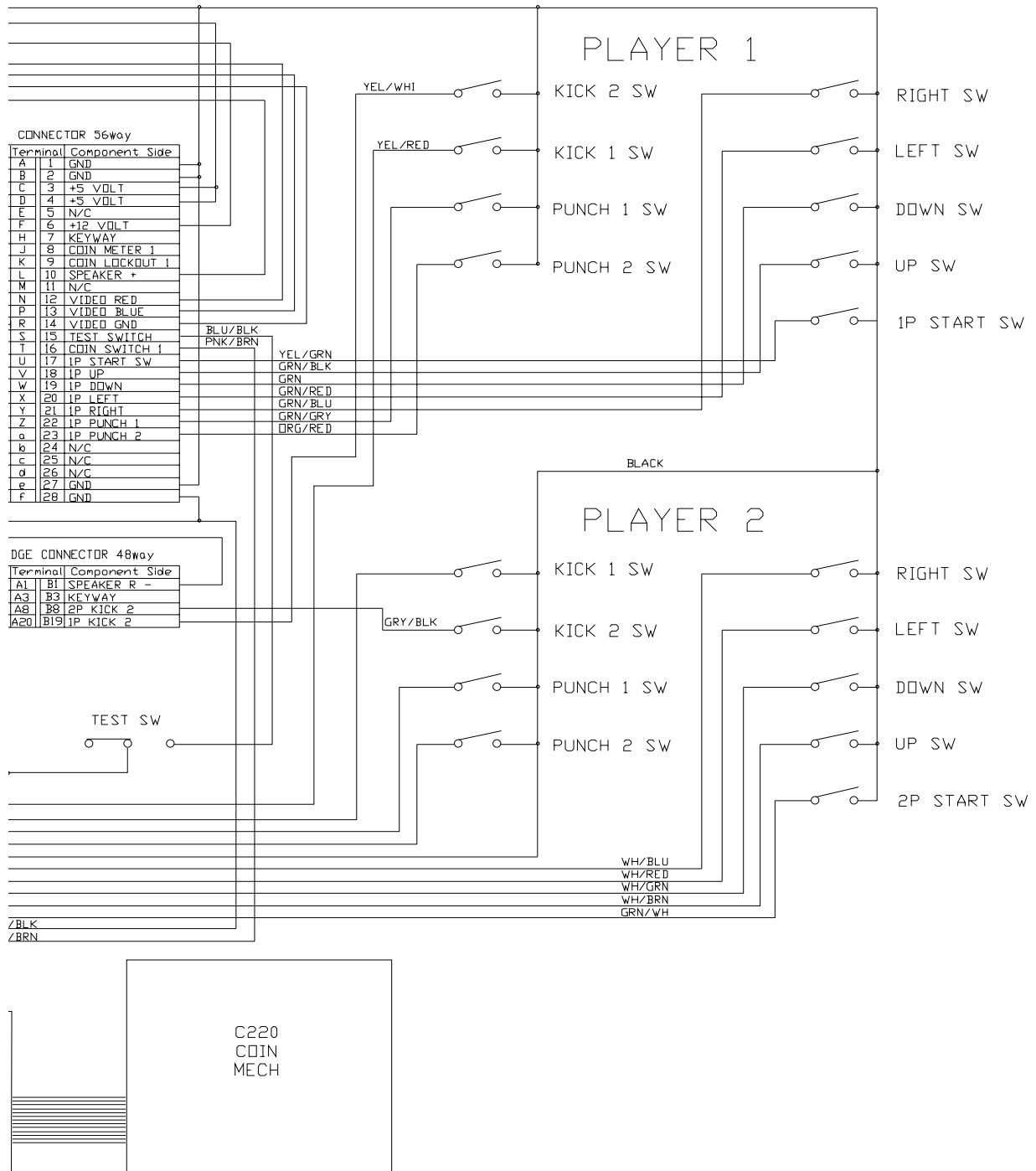

Contents

Operators Manual	1
1. SPECIFICATIONS	2
2. PRECAUTIONS	3
2-1 Cautions When Installing.	3
2-2 Cautions when Handling.	3
2-3 Cautions when Transporting.....	3
2-4 Cautions when handling the PCB.....	3
3. ADJUSTMENTS.....	4
3-1 Turning on the Power	4
3-2 Switches for Adjustment	4
3-3 Volume Adjust	4
3-4 Test Mode	5
3-4-1 Switch Test	5
3-4-2 Sound Test	6
3-4-3 Coin Options	7
3-4-4 Game Options	7
3-4-5 Factory Settings.....	8
4. PARTS.....	8
5. SCHEMATIC	10