

## Diesel Engine Compression Tester

Item 93644

### ⚠ WARNING

Read this material before using this product.  
Failure to do so can result in serious injury.  
**SAVE THIS MANUAL.**



When unpacking, make sure that the product is intact and undamaged.  
If any parts are missing or broken, please call 1-800-444-3353 as soon as possible.

Visit our website at: <http://www.harborfreight.com>

## Specifications

Pressure Scale	0-1000 PSI / 0-7000 kPa
Gauge Accuracy	± 2%
Air Release Type	Push Button
Hose Size	15/64 IN. I.D. x 35/64 IN. O.D. x 16 IN. L.
Accessories	Carrying Case, 9 adapter configurations

## Save This Manual

Keep this manual for the safety warnings and precautions, assembly, operating, inspection, maintenance and cleaning procedures. Write the product's serial number in the back of the manual near the assembly diagram (or month and year of purchase if product has no number). Keep this manual and the receipt in a safe and dry place for future reference.

# IMPORTANT SAFETY INFORMATION



**WARNING** Read all safety warnings and instructions. *Failure to follow the warnings and instructions may result in fire and/or serious injury.*

**Save all warnings and instructions for future reference.**

- Stay alert, watch what you are doing and use common sense when using the tester. Do not use while you are tired or under the influence of drugs, alcohol or medication.** *A moment of inattention while testing may result in serious personal injury.*
- Wear ANSI-approved safety goggles and heavy-duty work gloves during setup and use.**
- Do not overreach. Keep proper footing and balance at all times.**
- Dress properly. Do not wear loose clothing or jewelry. Keep your hair, clothing and gloves away from hot or moving parts.** *Loose clothes, jewelry or long hair can be caught in moving parts.*
- Use as intended only.**
- Store idle testers out of the reach of children and do not allow persons unfamiliar with the tester or these instructions to operate it.**
- Maintain the Tester. Check for breakage of parts and any other condition that may affect the tester's operation. If damaged, have the tester repaired before use.**
- Have your tester serviced by a qualified repair person using only identical replacement parts.** *This will ensure that the safety of the tester is maintained.*
- Maintain labels and nameplates on the tester. These carry important safety information. If unreadable or missing, contact Harbor Freight Tools for a replacement.
- Do not exceed 1000 PSI maximum pressure.
- Use the Tester only in well-ventilated areas. A running engine produces carbon monoxide. Carbon monoxide is a colorless, odorless, gas that, if inhaled, can cause serious injury or death.
- Before testing, place the transmission in park (or neutral for a manual transmission) and set the emergency brake.
- Keep hands and fingers away from moving parts and hot parts of vehicle's engine.
- This product is not a toy. Keep it out of reach of children.
- WARNING:** The brass components of this product contain lead, a chemical known to the State of California to cause birth defects (or other reproductive harm). (California Health & Safety code § 25249.5, *et seq.*)
- The warnings, precautions, and instructions discussed in this instruction manual cannot cover all possible conditions and situations that may occur. It must be understood by the operator that common sense and caution are factors which cannot be built into this product, but must be supplied by the operator.



**SAVE THESE INSTRUCTIONS.**

## Operating Instructions



Read the **ENTIRE IMPORTANT SAFETY INFORMATION** section at the beginning of this manual including all text under subheadings therein before set up or use of this product.

### **!WARNING**

**TO PREVENT SERIOUS INJURY AND/OR DEATH:**  
Avoid carbon monoxide poisoning. Do not run an engine in an enclosed garage or other contained area.

#### **TO PREVENT SERIOUS INJURY:**

- Wear appropriate work clothes, heavy-duty work gloves and ANSI-approved safety goggles when working on a hot engine. Keep hands away from the fan and other moving parts and protect yourself from electrical shock or burns. Be aware that working on an automotive or truck engine is inherently dangerous, and suitable precautions must be taken.
- If you are not experienced in doing this type of diagnostic test, the work should be done by a qualified technician.
- Install/remove the Tester only while the engine is stopped.

**Note:** Good engine cylinder compression will be indicated with a high initial reading, and a progressive buildup to the final maximum reading. Poor engine cylinder compression will be indicated with a low initial reading and a much slower buildup to the final maximum reading. The compression readings for all of the engine cylinders should not vary by more than 10%.

1. Check that the vehicle's battery is fully charged. Securely block the vehicle's tires, set the parking brake and the transmission to neutral or park.
2. Refer to the Diesel Adapters chart to select the proper Adapter to be used for the specific vehicle you will test. After identifying the correct adapter, assemble it securely as shown on the Parts List and Assembly Diagram on page 7.
3. Prepare the engine for compression testing by starting the engine and allowing it to warm up to its normal operating temperature. Then, switch off the engine.
4. Once the engine has been turned off, disconnect the fuel shutdown solenoid (refer to the engine maintenance manual for location).
5. Remove all of the injectors or all of the glow plugs (depending on the connector used). They can be labeled to aid during reassembly. Unless instructed to do so by the engine manual, do not inject oil into the cylinders (a "wet" test); the oil may not compress properly and damage the engine.
6. Connect the Compression Tester to an engine cylinder. With the fuel pedal depressed completely, crank the engine for eight revolutions. **Do not continue to crank the engine;** the engine's starter may overheat, damaging itself.
7. After cranking the engine, record the reading on the Pressure Gauge (1).
8. Once the maximum reading has been recorded, release the Gauge (1) pressure by depressing the Air Release Button (2).
9. **Use caution, the engine will be hot!** Remove the Compression Tester from the first cylinder.
10. Repeat steps 6-9 for the remaining cylinders.
11. Reconnect the fuel injection solenoid and reinstall all glow plugs/injectors.
12. When finished, clean, then store the Tester in its case, indoors, out of children's reach.

## Diesel Adapters

Manufacturer	Engine	Type	Thread	Adapter #
Audi®	Early models, see VW® for TDI	Injector	24 x 2.00	C
Mercedes-Benz®	Early models	Injector	24 x 2.00	C
VW®	1970's Rabbit®	Injector	24 x 2.00	C
Volvo®	Early models except 30's & 40's	Injector	24 x 2.00	C

BMW®	2.4L	Glow Plug	12 x 1.25	H <sup>U</sup>
Chevette®/Isuzu®; Luv®/Isuzu®	1.8L, 2.2L	Glow Plug	10 x 1.25	E
Deutz®	Many models	Glow Plug	12 x 1.25	H <sup>U</sup>
Ford®/Mazda®	(1984-87) 2.0L (1983-84) 2.2L Escort®, Lynx®, Ranger®, Tempo®, Topaz®	Glow Plug	10 x 1.25	F
Ford®/Mitsubishi®	(1985-87) Ranger® 2.3L	Glow Plug	10 x 1.25	F
Ford®/Navistar®	6.9L and 7.3L (up to 1994)	Glow Plug	10 x 1.00	A
General Motors®	4.3L V6, 4.3L V8, 5.7L V8	Glow Plug	10 x 1.00	A
	Duramax® 6.6L Turbo Diesel	Glow Plug	10 x 1.25	E
Hummer®	Optimizer 6500® V8 Turbo	Glow Plug	10 x 1.25	E
Isuzu®/Isuzu® Truck	(1992-98) 4HE1-TC (1998-2005) 6HK1-TC	Glow Plug	10 x 1.25	E
	(1998-2005) 4HE1-TC (Up to 1998) 6HK1-TC	Glow Plug	12 x 1.25	H <sup>U</sup> U
Kubota®	Some models	Glow Plug	10 x 1.25	F
Lincoln®, Mark VII® Continental®	2.4L used in 1984-85 autos	Glow Plug	12 x 1.25	H
	with Volvo® engines	Glow Plug	10 x 1.25	F
Mercedes-Benz®	(1988-89) 190E 2.5L	Glow Plug	12 x 1.25	I <sup>U</sup>
	(1991-99) E300	Glow Plug	12 x 1.25	H <sup>U</sup>
	2005 E320 CDI	Glow Plug	10 x 1.00	A
Mitsubishi®	2 and 3 cylinder engines	Glow Plug	10 x 1.25	F
Mitsubishi-Fuso®	Medium	Glow Plug	10 x 1.25	F
Navistar®/ International®	6.9L and 7.3L	Glow Plug	10 x 1.00	A
Nissan®/ UD Truck®	2.2L	Glow Plug	10 x 1.25	F
	Medium	Glow Plug	10 x 1.25	F
Peugeot®	Most	Glow Plug	12 x 1.25	H <sup>U</sup>
	Certain Models	Glow Plug	18 x 1.50	H
Toyota®	1.8L	Glow Plug	10 x 1.25	E
	2.2L	Glow Plug	10 x 1.25	F
VW®	(1979-84) Rabbit® (1979-99) Jetta® (1981-84) Pick-Up (1987-99) Golf® (1992-97) Passat® (1992-98) Eurovan®	Glow Plug	12 x 1.25	H <sup>U</sup> U
	(1995-97) Passat® (1997-05) Golf® (1997-05) Jetta® & Jetta® Wagon (1998-05) New Beetle® 2004 Touareg®	Glow Plug	10 x 1.00	A

<sup>U</sup> - Indicates that part 7 must be removed for these applications.

## Maintenance



Procedures not specifically explained in this manual must be performed only by a qualified technician.

### **!WARNING**

**TO PREVENT SERIOUS INJURY FROM TOOL FAILURE:**

**Do not use damaged equipment.**

**If abnormal noise, vibration, or leaking air occurs, have the problem corrected before further use.**

1. **Before each use**, inspect the general condition of the Tester. Check for cracked, worn or damaged Adapters, damaged Pressure Gauge and Hose, and any other condition that may affect the tester's safe operation. If a problem occurs, have the problem corrected before further use.  
**Do not use damaged equipment.**
2. **To clean**, use a damp cloth and a mild detergent.
3. **When storing**, keep the Tester and components in a clean, dry, safe location out of reach of children.

# Parts List and Assembly Diagram

Part	Description	Qty
1	Pressure Gauge	1
2	Air Release Button	1
3	Rubber Hose	1
4	1/8" NPT Quick Coupler	1
5	7/16"-20 (F) Quick Coupler	3
6	M12 x 1.25 (M)-7/16"-20 (M) Adapter	3
7	M12 x 1.25 (F)-M18 x 1.5 (M) Adapter	2
8	M10 x 1.25 Short Adapter	1
9	M10 x 1.25 Long Adapter	1

Part	Description	Qty
10	ZG 1/8" (M) Male Quick Coupler	1
11	ZG 1/8" (F)-M24 x 2 (M) Adapter	1
12	Adapter Sleeve	1
13	Quick Connect with Ball Tip	1
14	1/2"-19 Lock Nut	1
15	7/16"-20 (M)-7/16" x 20 (F) 90° Connector	1
16	ZG 1/8" (M)-M24 x 1.5 (M) Adapter	1
17	M10 x 1 (M) Adapter	1
18	Copper Washer	2

Letters designate adapter assemblies.

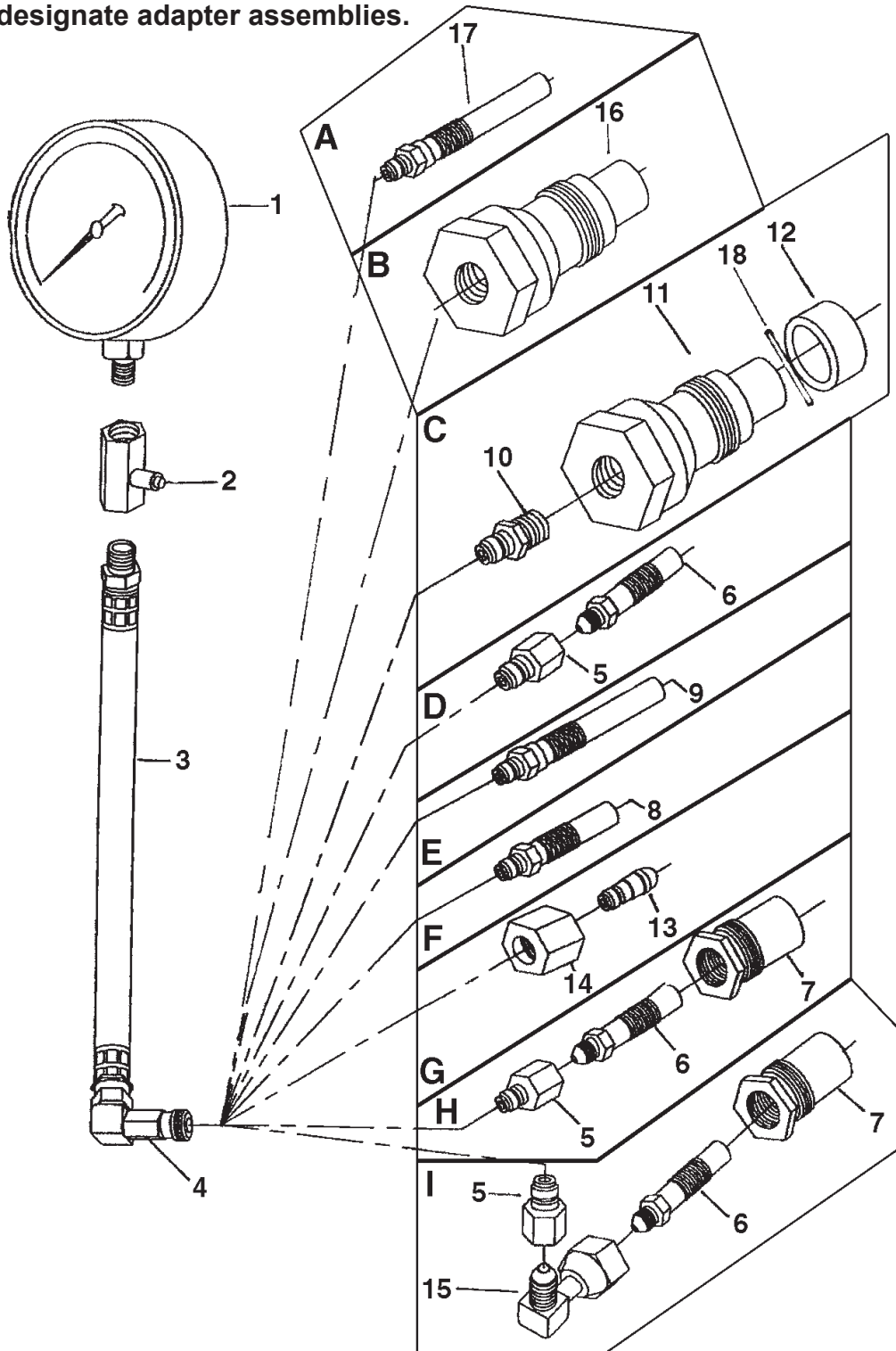

## PLEASE READ THE FOLLOWING CAREFULLY

THE MANUFACTURER AND/OR DISTRIBUTOR HAS PROVIDED THE PARTS LIST AND ASSEMBLY DIAGRAM IN THIS MANUAL AS A REFERENCE TOOL ONLY. NEITHER THE MANUFACTURER OR DISTRIBUTOR MAKES ANY REPRESENTATION OR WARRANTY OF ANY KIND TO THE BUYER THAT HE OR SHE IS QUALIFIED TO REPLACE ANY PARTS OF THE PRODUCT. IN FACT, THE MANUFACTURER AND/OR DISTRIBUTOR EXPRESSLY STATES THAT ALL REPAIRS AND PARTS REPLACEMENTS SHOULD BE UNDERTAKEN BY CERTIFIED AND LICENSED TECHNICIANS, AND NOT BY THE BUYER. THE BUYER ASSUMES ALL RISKS AND LIABILITY ARISING OUT OF HIS OR HER REPAIRS TO THE ORIGINAL PRODUCT OR REPLACEMENT PARTS THERETO, OR ARISING OUT OF HIS OR HER INSTALLATION OF REPLACEMENT PARTS THERETO.

**Record Product's Serial Number Here:** \_\_\_\_\_

**Note:** If product has no serial number, record month and year of purchase instead.

**Note:** Some parts are listed and shown for illustration purposes only, and are not available individually as replacement parts.

### Limited 90 Day Warranty

Harbor Freight Tools Co. makes every effort to assure that its products meet high quality and durability standards, and warrants to the original purchaser that this product is free from defects in materials and workmanship for the period of 90 days from the date of purchase. This warranty does not apply to damage due directly or indirectly, to misuse, abuse, negligence or accidents, repairs or alterations outside our facilities, criminal activity, improper installation, normal wear and tear, or to lack of maintenance. We shall in no event be liable for death, injuries to persons or property, or for incidental, contingent, special or consequential damages arising from the use of our product. Some states do not allow the exclusion or limitation of incidental or consequential damages, so the above limitation of exclusion may not apply to you. THIS WARRANTY IS EXPRESSLY IN LIEU OF ALL OTHER WARRANTIES, EXPRESS OR IMPLIED, INCLUDING THE WARRANTIES OF MERCHANTABILITY AND FITNESS.

To take advantage of this warranty, the product or part must be returned to us with transportation charges prepaid. Proof of purchase date and an explanation of the complaint must accompany the merchandise. If our inspection verifies the defect, we will either repair or replace the product at our election or we may elect to refund the purchase price if we cannot readily and quickly provide you with a replacement. We will return repaired products at our expense, but if we determine there is no defect, or that the defect resulted from causes not within the scope of our warranty, then you must bear the cost of returning the product.

This warranty gives you specific legal rights and you may also have other rights which vary from state to state.

**PITTSBURGH<sup>®</sup> AUTOMOTIVE**