

RGM-2106 Operational Manual

Version 0.2
2010/12/08

This document contains information highly confidential to RoyalTek Company LTD (RoyalTek). It is provided for the sole purpose of the business discussions between supplier and RoyalTek and is covered under the terms of the applicable Non-Disclosure Agreements. Disclosure of this information to other parties is prohibited without the written consent of RoyalTek.

Prepared by RoyalTek Company LTD.

4F., No.188, Wen Hwa 2nd Rd., Kuei Shan,
Tao Yuan 333, Taiwan

TEL: 886-3-3960001
FAX: 886-3-3960065

<http://www.royaltek.com/contact>

1	Introduction.....	2
1.1	Product applications	2
1.2	Product Picture	3
1.3	RGM-2106 System Block Diagram.....	3
1.4	RGM-2106 Technical Specification	4
1.5	Application Circuit.....	5
1.6	Mechanical	6
1.7	Hardware interface	6
2	Software Interface	9
2.1	NMEA V3.0 Protocol.....	9
2.1.1	GGA-Global Positioning System Fixed Data	9
2.1.2	GLL-Geographic Position –Latitude/Longitude.....	10
2.1.3	GSA-GNSS DOP and Active Satellites.....	11
2.1.4	GSV-GNSS Satellites in View	11
2.1.5	RMC-Recommended Minimum Specific GNSS Data	12
2.1.6	VTG-Course Over Ground and Ground Speed.....	13
3	Contact Information Section	14
4	Revision History	14

1 Introduction

RoyalTek RGM-2106 is the smart antenna GPS module with SiRFstar IV GPS solution. The module embedded active Jammer remover to ensure fast and accurate navigation in hostile signal/high noise environment. Power by the new SiRFStar IV architecture, the module can acquire satellites as low as -163dBm better than SiRF Star III. The high sensitivity, low power, 48-channel GPS module is the best choice to be embedded in a portable device such as Car tracking device, Locator application, safety alarm device, personal locator and digital camera.

Product Features

- ✧ Wire to board connector type
- ✧ Additional 3 dB in track sensitivity is better than the SiRF Star III.
- ✧ Support MEMS Sensor to detection and wake up the device for power saving and longer battery life.
- ✧ Adaptive Micro-power controller- only 50 to 500uA to maintain hot start capability.
- ✧ Embedded InstantFix CGEE and Reverse CGEE (3 days) for faster warm start.
- ✧ Embedded active Jammer remover to ensure fast and accurate navigation in hostile signal environments – GSM, NB environments

1.1 Product applications

- ✧ Personal Navigation Device including GPS PDA and GPS Handheld
- ✧ Pet/personal Tracker, AVL / Location-Based Services Tracker
- ✧ Cameras / Digital camcorder

1.2 Product Picture



Figure 1-1 RGM-2106 Front View

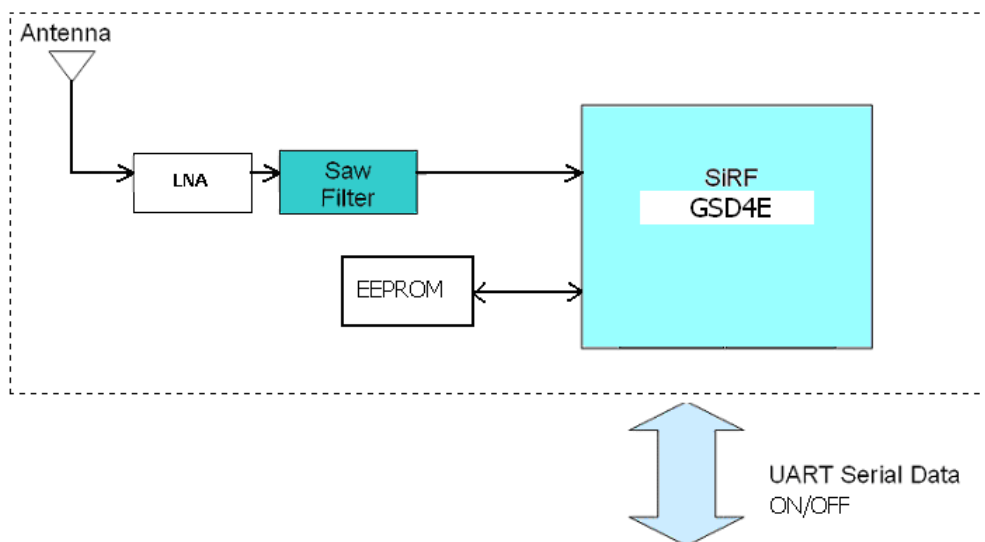

Figure 1-2 RGM-2106 Bottom View

1.3 RGM-2106 System Block Diagram

System block diagram description :

- External antenna.
- 6 pin I/O pin



1.4 RGM-2106 Technical Specification

Impedance : 50Ω

No	Function	Specification
GPS receiver		
1	Chipset	SiRFstarIV GSD4e-9311-TR Signature ROM
2	Frequency	L1 1575.42MHz
3	Code	C.A. Code.
4	Channels	48 track verification channels
5	Chipset Sensitivity	High sensitivity navigation engine (PVT) tracks as low as -163dBm
6	Chipset Cold start	35 sec (open sky)
7	Chipset Warm start	35 sec (open sky)
8	Hot start	1 sec (open sky)
9	Reacquisition	0.1sec typical
10	Position accuracy	2.5meters(50% 24hr static, -130dBm)
11	Maximum altitude	18288 m
12	Maximum velocity	514 m/s
13	Update rate	1Hz
14	Protocol setup	NMEA0183 standard V3.01 and backward compliance-Adjustable by firmware
15	LNA	Embedded 1 stage LNA
16	SBAS(Optional)	WAAS, EGNOS
17	Active Jammer Remover:	<ul style="list-style-type: none"> ■ Removes in-band jammers up to 80 dB-Hz ■ Tracks up to 8 CW jammers
Interface		
18	I/O Pin	6pins
Power consumption		
19	VCC	DC +1.8V@ ±5%
20	Current	Normal mode :Avg. ≤ 65mA@1.8V(without ext. antenna) Hibernate mode: Avg. ≤30uA @1.8V(without ext. antenna)
Environment		
21	Temperature	Operating : -30 ~ 85°C Storage : -40 ~ 85°C
22	Humidity	≤95%

1.5 Application Circuit

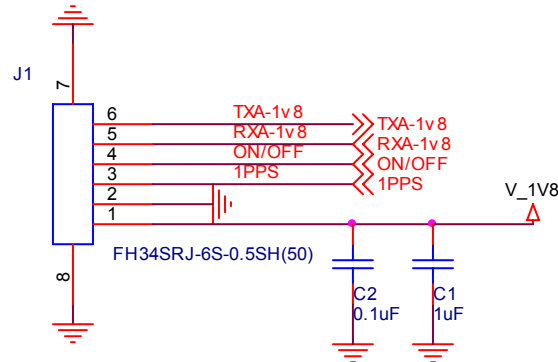

Note:

- **V_1V8 (DC 1.8V@ 5% power Input)**
This is the DC power supply input pin for GPS system. It provides voltage to module.
- **GND**
GND provides the ground.
- **RXD**
This is the main receiver channel and is used to receive software commands to the board from SIRFdemo software or from user written software.
- **TXD**
This is the main transmitting channel and is used to output navigation and measurement data to SiRFdemo or user written software.
- **PPS (TIMEMARK)**
This pin provides one pulse-per-second output from the board, which is synchronized to GPS time. Need firmware supporting. If don't used, can open.
Note: **At present PPS function has not opened.**
- **Power**
Connect VCC_IN_1V8 pin to DC 1.8V. The power supply must add bypass capacitor (10uF and 1uF).It can reduce the Noise from power supply and increase power stability.
- **Shutdown**
Shutdown the RGM-2106 module, don't remove the Vcc_IN_1V8 Pin, must be use on/off pulse make it into Hibernate mode.(It's will keep the Warm start and Hot start function work well)
- **ON/OFF**
Input pulse is required to start the system, and switch the operation mode tofull-power mode or Hibernate mode.

1.6 Mechanical

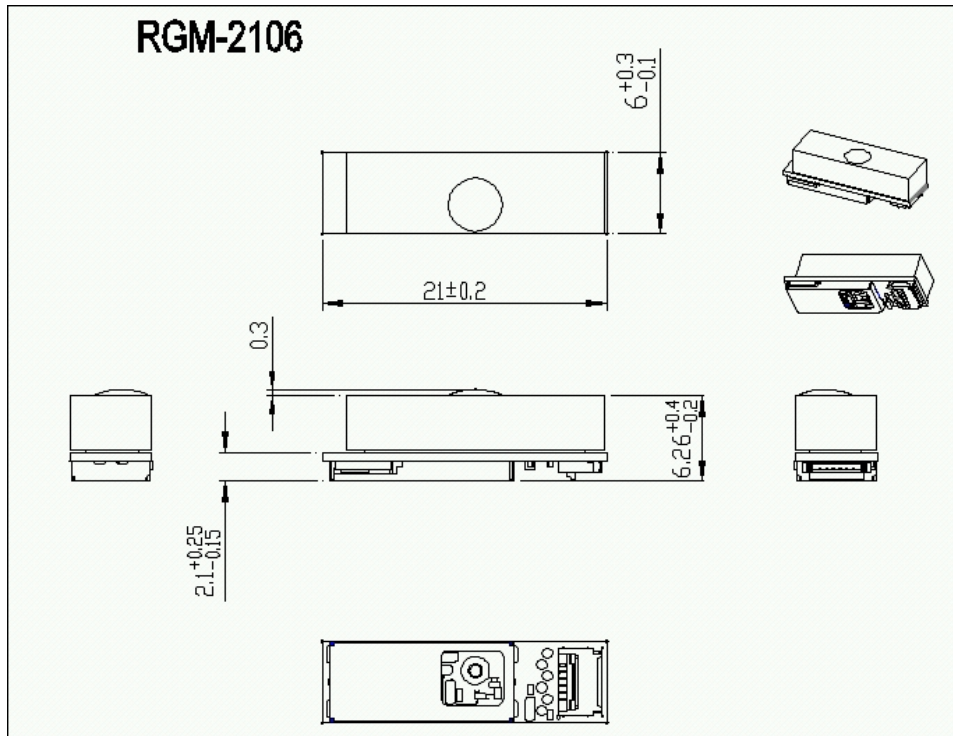

1.7 Hardware interface

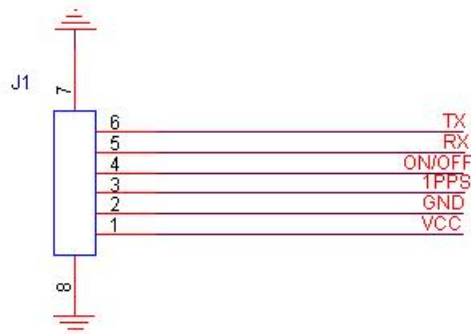
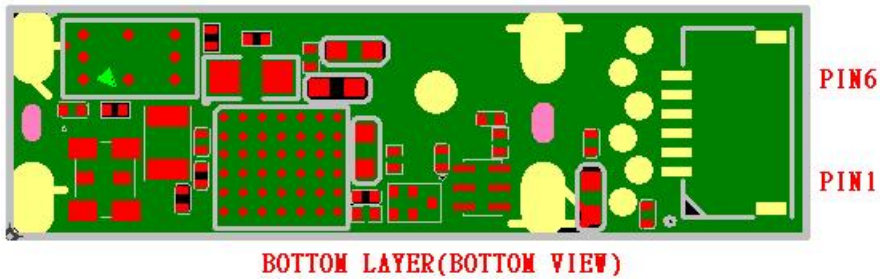

FH34SRJ-6S-0.5SH(50)

Pin Definition

Pin	Signal Name	I/O	Description	Characteristics
1	VCC_1V8	I	DC Supply Voltage input	DC +1.8V, RANGE : 1.71~1.89V
2	GND	G	Ground	Reference Ground
3	PPS	O	One pulse per second	$V_{OH} \geq 1.35V$ $V_{OL} \leq 0.4V$
4	ON_OFF	I	Edge triggered soft on/off request	Power control pin ,need a pulse to ON or OFF the Chip set. (CMOS I/O run from 1.8v)
5	RXD	I	Serial port A	$3.6V \geq V_{IH} \geq 1.26V$ $-0.4V \leq V_{IL} \leq 0.45V$
6	TXD	O	Serial port A	$V_{OH} \geq 1.35V$ $V_{OL} \leq 0.4V$

Definition of Pin assignment

- V_1V8 (DC 1.8V@ 5% power Input)
This is the DC power supply input pin for GPS system. It provides voltage to module.
- GND
GND provides the ground.
- RXD
This is the main receiver channel and is used to receive software commands to the board from SIRFdemo software or from user written software.
- TXD
This is the main transmitting channel and is used to output navigation and measurement data to SiRFDemo or user written software.
- PPS (TIMEMARK)
This pin provides one pulse-per-second output from the board, which is synchronized to GPS time. Need firmware supporting. If don't used, can open.
Note: At present the PPS function has not open.
- Power
Connect VCC_IN_1V8 pin to DC 1.8V. The power supply must add bypass capacitor (10uF and 1uF).It can reduce the Noise from power supply and increase power stability.
- Shutdown
Shutdown the RGM-2106 module, don't remove the Vcc_IN_1V8 Pin, must be use on/off pulse make it into Hibernate mode.(It's will keep the Warm start and Hot start function work well)
- ON/OFF
Input pulse is required to start the system, and switch the operation mode to full-power mode or Hibernate mode.

2 Software Interface

2.1 NMEA V3.0 Protocol

Its output signal level is TTL. It can support the following NMEA-0183 sentence.

Messages: GGA, GLL, GSA, GSV, RMC and VTG.

NMEA Output Messages: the Engine board outputs the following messages as shown in Table 2-1:

Table 2-1 NMEA-0183 Output Messages

NMEA Record	Description
GGA	Global positioning system fixed data
GLL	Geographic position – latitude / longitude
GSA	GNSS DOP and active satellites
GSV	GNSS satellites in view
RMC	Recommended minimum specific GNSS data
VTG	Course over ground and ground speed

2.1.1 GGA-Global Positioning System Fixed Data

Table 2-2 contains the values of the following example:

\$GPGGA, 161229.487, 3723.2475, N, 12158.3416, W, 1, 07, 1.0, 9.0, M, , , , 0000*18

Table 2-2 GGA Data Format

Name	Example	Units	Description
Message ID	\$GPGGA		GGA protocol header
UTC Position	161229.487		hhmmss.sss
Latitude	3723.2475		ddmm.mmmm
N/S Indicator	N		N=north or S=south
Longitude	12158.3416		Dddmm.mmmm
E/W Indicator	W		E=east or W=west
Position Fix Indicator	1		See Table 2-1
Satellites Used	07		Range 0 to 12
HDOP	1.0		Horizontal Dilution of Precision
MSL Altitude	9.0	meters	
Units	M	meters	
Geoid Separation		meters	
Units	M	meters	

Age of Diff. Corr.		second	Null fields when DGPS is not used
Diff. Ref. Station ID	0000		
Checksum	*18		
<CR> <LF>			End of message termination

Table 2-3 Position Fix Indicators

Value	Description
0	Fix not available or invalid
1	GPS SPS Mode, fix valid
2	Differential GPS, SPS Mode, fix valid
3-5	Not Supported GPS PPS Mode, fix valid
6	Dead Reckoning Mode, fix valid

2.1.2 GLL-Geographic Position –Latitude/Longitude

Table 2-4 contains the values of the following

Example: \$GPGLL, 3723.2475, N, 12158.3416, W, 161229.487, A*2C

Table 2-4 GLL Data Format

Name	Example	Units	Description
Message ID	\$GPGLL		GLL protocol header
Latitude	3723.2475		ddmm.mmmm
N/S Indicator	N		N=north or S=south
Longitude	12158.3416		Dddmm.mmmm
E/W Indicator	W		E=east or W=west
UTC Position	161229.487		hhmmss.ss
Status	A		A=data valid or V=data not valid
Mode	A		A=Autonomous, D=DGPS, E=DR
Checksum	*2C		
<CR> <LF>			End of message termination

2.1.3 GSA-GNSS DOP and Active Satellites

Table 2-5 contains the values of the following example:

\$GPGSA, A, 3, 07, 02, 26, 27, 09, 04, 15, , , , , 1.8,1.0,1.5*33

Table 2-5 GSA Data Format

Name	Example	Units	Description
Message ID	\$GPGSA		GSA protocol header
Mode 1	A		See Table 4-2
Mode 2	3		See Table 4-1
Satellite Used	07		Sv on Channel 1
Satellite Used	02		Sv on Channel 2
....		
Satellite Used			Sv on Channel 12
PDOP	1.8		Position Dilution of Precision
HDOP	1.0		Horizontal Dilution of Precision
VDOP	1.5		Vertical Dilution of Precision
Checksum	*33		
<CR><LF>			End of message termination

Table 2-6 Mode 1

Value	Description
1	Fix not available
2	2D
3	3D

Table 2-7 Mode 2

Value	Description
M	Manual-forced to operate in 2D or 3D mode
A	Automatic-allowed to automatically switch 2D/3D

2.1.4 GSV-GNSS Satellites in View

Table 2-8 contains the values of the following example:

\$GPGSV, 2, 1, 07, 07, 79, 048, 42, 02, 51, 062, 43, 26, 36, 256, 42, 27, 27, 138, 42*71\$GPGSV, 2, 2, 07, 09, 23, 313, 42, 04, 19, 159, 41, 15, 12, 041, 42*41

Table 2-8 GSV Data Format

Name	Example	Units	Description
Message ID	\$GPGSV		GSV protocol header
Number of Messages ¹	2		Range 1 to 3
Messages Number ¹	1		Range 1 to 3
Satellites in View	07		
Satellite ID	07		Channel 1(Range 1 to 32)
Elevation	79	degrees	Channel 1(Maximum 90)
Azimuth	048	degrees	Channel 1(True, Range 0 to 359)
SNR (C/No)	42	dBHz	Range 0 to 99, null when not tracking
....		
Satellite ID	27		Channel 4(Range 1 to 32)
Elevation	27	degrees	Channel 4(Maximum 90)
Azimuth	138	degrees	Channel 4(True, Range 0 to 359)
SNR (C/No)	42	dBHz	Range 0 to 99, null when not tracking
Checksum	*71		
<CR> <LF>			End of message termination

¹Depending on the number of satellites tracked multiple messages of GSV data may be required.

2.1.5 RMC-Recommended Minimum Specific GNSS Data

Table 2-9 contains the values of the following example:

\$GPRMC, 161229.487, A, 3723.2475, N, 12158.3416, W, 0.13, 309.62, 120598, ,*10

Table 2-9 RMC Data Format

Name	Example	Units	Description
Message ID	\$GPRMC		RMC protocol header
UTC Position	161229.487		hhmmss.sss
Status	A		A=data valid or V=data not valid
Latitude	3723.2475		ddmm.mmmm
N/S Indicator	N		N=north or S=south
Longitude	12158.3416		dddmm.mmmm

E/W Indicator	W		E=east or W=west
Speed Over Ground	0.13	knots	
Course Over Ground	309.62	degrees	True
Date	120598		ddmmyy
Magnetic Variation		degrees	E=east or W=west
Mode	A		A=Autonomous, D=DGPS, E=DR
Checksum	*10		

2.1.6 VTG-Course Over Ground and Ground Speed

Table 2-10 contains the values of the following example:

\$GPVTG, 309.62, T, , M, 0.13, N, 0.2, K*6E

Table 2-10 VTG Data Format

Name	Example	Units	Description
Message ID	\$GPVTG		VTG protocol header
Course	309.62	degrees	Measured heading
Reference	T		True
Course		degrees	Measured heading
Reference	M		Magnetic
Speed	0.13	knots	Measured horizontal speed
Units	N		Knots
Speed	0.2	km/hr	Measured horizontal speed
Units	K		Kilometer per hour
Mode	A		A=Autonomous, D=DGPS, E=DR
Checksum	*6E		
<CR> <LF>			End of message termination

3 Contact Information Section

Contact: sales@royaltek.com

Headquarter:

Address: 4F., No.188, Wen Hwa 2nd Rd., Kuei Shan, Tao Yuan 333, Taiwan

TEL: 886-3-3960001

FAX: 886-3-3960065

Web Site: <http://www.royaltek.com>

Web Site Customer Service: <http://www.royaltek.com/contact>

4 Revision History

Title	RGM-2106 GPS Smart Antenna		
Doc Type	Operational Manual		
Revision Number	Date	Author	Change notice
0.1	2010/11/15	May Chen	Initial Released