

Read and Understand this Catalog

Please read and understand this catalog before purchasing the product. Please consult your OMRON representative if you have any questions or comments.

Warranty and Limitations of Liability

WARRANTY

OMRON's exclusive warranty is that the products are free from defects in materials and workmanship for a period of one year (or other period if specified) from date of sale by OMRON.

OMRON MAKES NO WARRANTY OR REPRESENTATION, EXPRESS OR IMPLIED, REGARDING NON-INFRINGEMENT, MERCHANTABILITY, OR FITNESS FOR PARTICULAR PURPOSE OF THE PRODUCTS. ANY BUYER OR USER ACKNOWLEDGES THAT THE BUYER OR USER ALONE HAS DETERMINED THAT THE PRODUCTS WILL SUITABLY MEET THE REQUIREMENTS OF THEIR INTENDED USE. OMRON DISCLAIMS ALL OTHER WARRANTIES, EXPRESS OR IMPLIED.

LIMITATIONS OF LIABILITY

OMRON SHALL NOT BE RESPONSIBLE FOR SPECIAL, INDIRECT, OR CONSEQUENTIAL DAMAGES, LOSS OF PROFITS OR COMMERCIAL LOSS IN ANY WAY CONNECTED WITH THE PRODUCTS, WHETHER SUCH CLAIM IS BASED ON CONTRACT, WARRANTY, NEGLIGENCE, OR STRICT LIABILITY.

In no event shall the responsibility of OMRON for any act exceed the individual price of the product on which liability is asserted. IN NO EVENT SHALL OMRON BE RESPONSIBLE FOR WARRANTY, REPAIR, OR OTHER CLAIMS REGARDING THE PRODUCTS UNLESS OMRON'S ANALYSIS CONFIRMS THAT THE PRODUCTS WERE PROPERLY HANDLED, STORED, INSTALLED, AND MAINTAINED AND NOT SUBJECT TO CONTAMINATION, ABUSE, MISUSE, OR INAPPROPRIATE MODIFICATION OR REPAIR.

Application Considerations

SUITABILITY FOR USE

OMRON shall not be responsible for conformity with any standards, codes, or regulations that apply to the combination of the product in the customer's application or use of the product.

Take all necessary steps to determine the suitability of the product for the systems, machines, and equipment with which it will be used.

Know and observe all prohibitions of use applicable to this product.

NEVER USE THE PRODUCT FOR AN APPLICATION INVOLVING SERIOUS RISK TO LIFE OR PROPERTY WITHOUT ENSURING THAT THE SYSTEM AS A WHOLE HAS BEEN DESIGNED TO ADDRESS THE RISKS, AND THAT THE OMRON PRODUCT IS PROPERLY RATED AND INSTALLED FOR THE INTENDED USE WITHIN THE OVERALL EQUIPMENT OR SYSTEM.

PROGRAMMABLE PRODUCTS

OMRON shall not be responsible for the user's programming of a programmable product, or any consequence thereof.

Disclaimers

CHANGE IN SPECIFICATIONS

Product specifications and accessories may be changed at any time based on improvements and other reasons. Consult with your OMRON representative at any time to confirm actual specifications of purchased product.

DIMENSIONS AND WEIGHTS

Dimensions and weights are nominal and are not to be used for manufacturing purposes, even when tolerances are shown.

PERFORMANCE DATA

Performance data given in this catalog is provided as a guide for the user in determining suitability and does not constitute a warranty. It may represent the result of OMRON's test conditions, and the users must correlate it to actual application requirements. Actual performance is subject to the OMRON Warranty and Limitations of Liability.

Note: Do not use this document to operate the Unit.

Printed on 100%
Recycled Paper



OMRON Corporation

Control Devices Division H.Q.

Shiokoji Horikawa, Shimogyo-ku,
Kyoto, 600-8530
Japan
Tel: (81)75-344-7109
Fax: (81)75-344-7149

Regional Headquarters

OMRON EUROPE B.V.

Wegalaan 67-69, NL-2132 JD Hoofddorp
The Netherlands
Tel: (31)2356-81-300/
Fax: (31)2356-81-388

OMRON ELECTRONICS LLC

1 East Commerce Drive, Schaumburg,
IL 60173 U.S.A.
Tel: (1)847-843-7900/Fax: (1)847-843-8568

OMRON ASIA PACIFIC PTE. LTD.

83 Clemenceau Avenue,
#11-01, UE Square,
Singapore 239920
Tel: (65)6835-3011/Fax: (65)6835-2711

OMRON (CHINA) CO., LTD.

Room 2211, Bank of China Tower,
200 Yin Cheng Zhong Road,
PuDong New Area, Shanghai, 200120 China
Tel: (86)21-5037-2222/Fax: (86)21-5037-2200

Authorized Distributor:

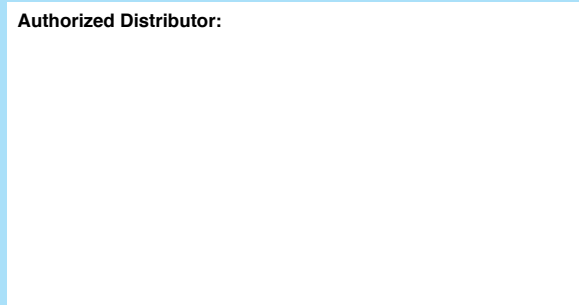

Note: Specifications subject to change without notice.

Cat. No. V078-E1-09
Printed in Japan
0206-1M

OMRON

NS12-V2 12-inch Model
NS10-V2 10-inch Model
NS8-V2 8-inch Model

NS5-V2 5-inch Model
NSH5 5-inch Hand-held Model

Programmable Terminals

NS-CXDC1-V1



NS-series Screen Creation Software

Installing a Navigator: A Totally New Concept in Programmable Terminals



realizing

Navigator for System

NS Series

Make it More Simple

The NS is moving to the next stage, from a touch screen to an advanced machine management tool.



It's convenient but...



Seamless

We are always trying to provide solutions that will give the highest added value to your system. We strive to solve on-site problems with our solutions instead of just providing touch screen functions. That is what OMRON is focused on.

Switch Operation

Touch Screen Operation

Machine Management



It's convenient but...



Smart

Turning switches into Touch Screens brings enhancements, such as minimum wiring, space savings, and improved local operation efficiency. Moreover, OMRON works to minimize the customer's energy expenditure from machine design to troubleshooting.

OK!

NS Enters a New Zone

From PLC Memory Allocation to Device Access

Previous PTs shared data that was allocated in advance to specific words in the CPU Unit, and they were used to assist with device operations, and to display error locations, and countermeasures.

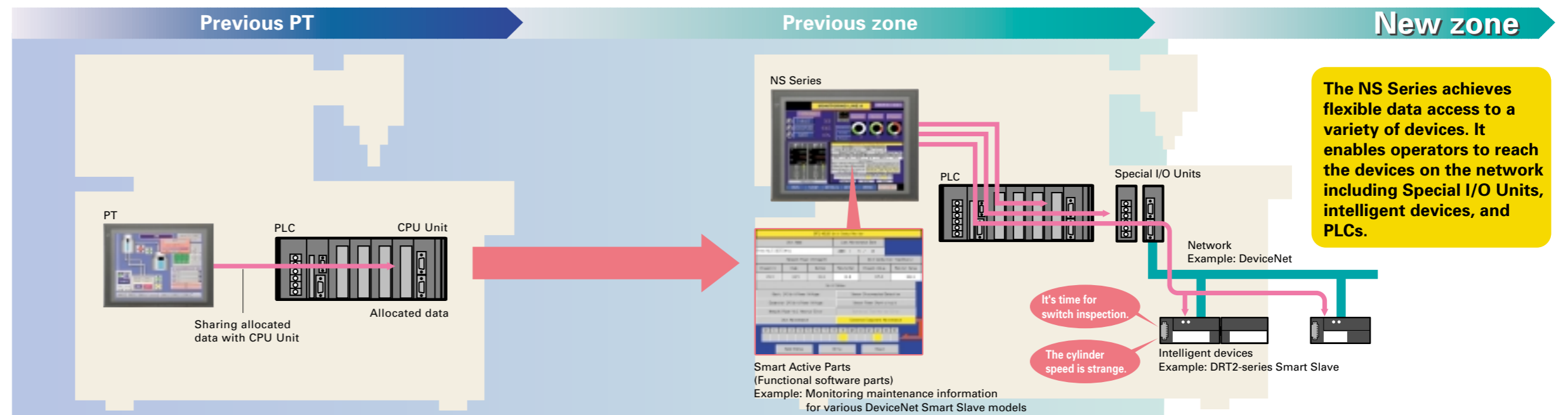

PTs as a Machine Navigator

NS-series PTs navigate all areas of machine operation, from daily operation to error recovery.



The PT is traditionally a terminal that exchanges data in allocated areas with the PLC's CPU Unit. The internal and external control of a PLC with only this type of data exchange is, however, difficult. A NS-series PT, however, uses communications functions and Smart Active Parts to incorporate software computer functions to operate as a Device Navigator.

- Device operations
- Displaying device error locations
- Displaying countermeasures
- Internal device monitoring and resetting (Supporting recovery methods)

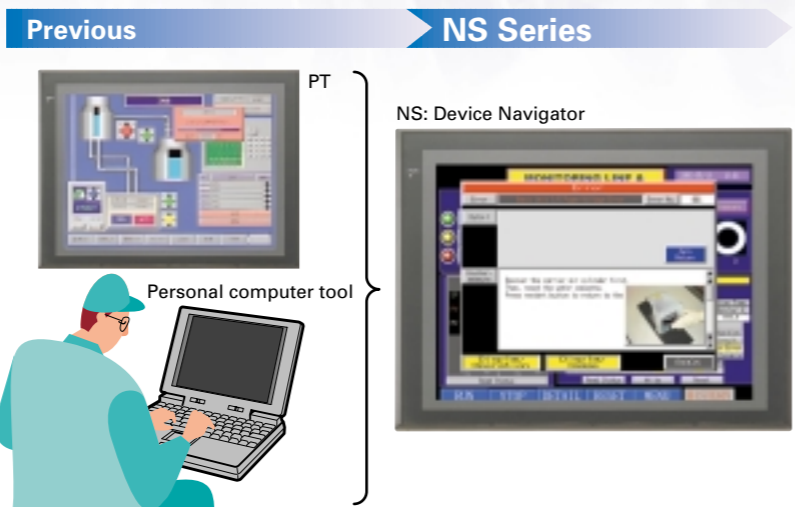

With version 2 PTs (V2 suffix in model number), hardware functions are upgraded.

Large Capacity

NS8-V2/NS10-V2/NS12-V2: 60 MB
 (-V1: 20 MB, same as before)
 NS5-V2: 20 MB

Note: The NS5-V1 has a capacity of 6 MB.

Increased Visibility

NS8-V2: Increased from 8.0 to 8.4 inches
 NS5-V2(STN)/NS12: Wider field of vision

Don't you have these problems?

The Smart Active Parts are the solution.

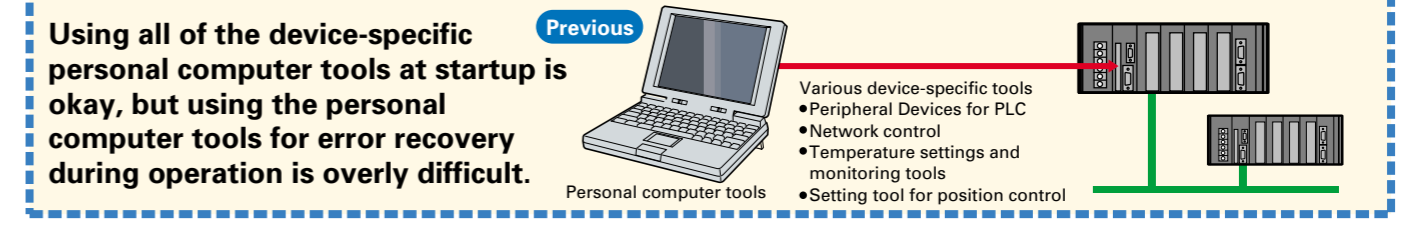

Wouldn't it be simpler to use the PT instead?

OMRON ORIGINAL With an NS-series PT, just drag and drop Smart Active Parts to customize the interface for your machine.

Only with NS! NS-series PTs provide Smart Active Parts that allow direct data access to a variety of devices.

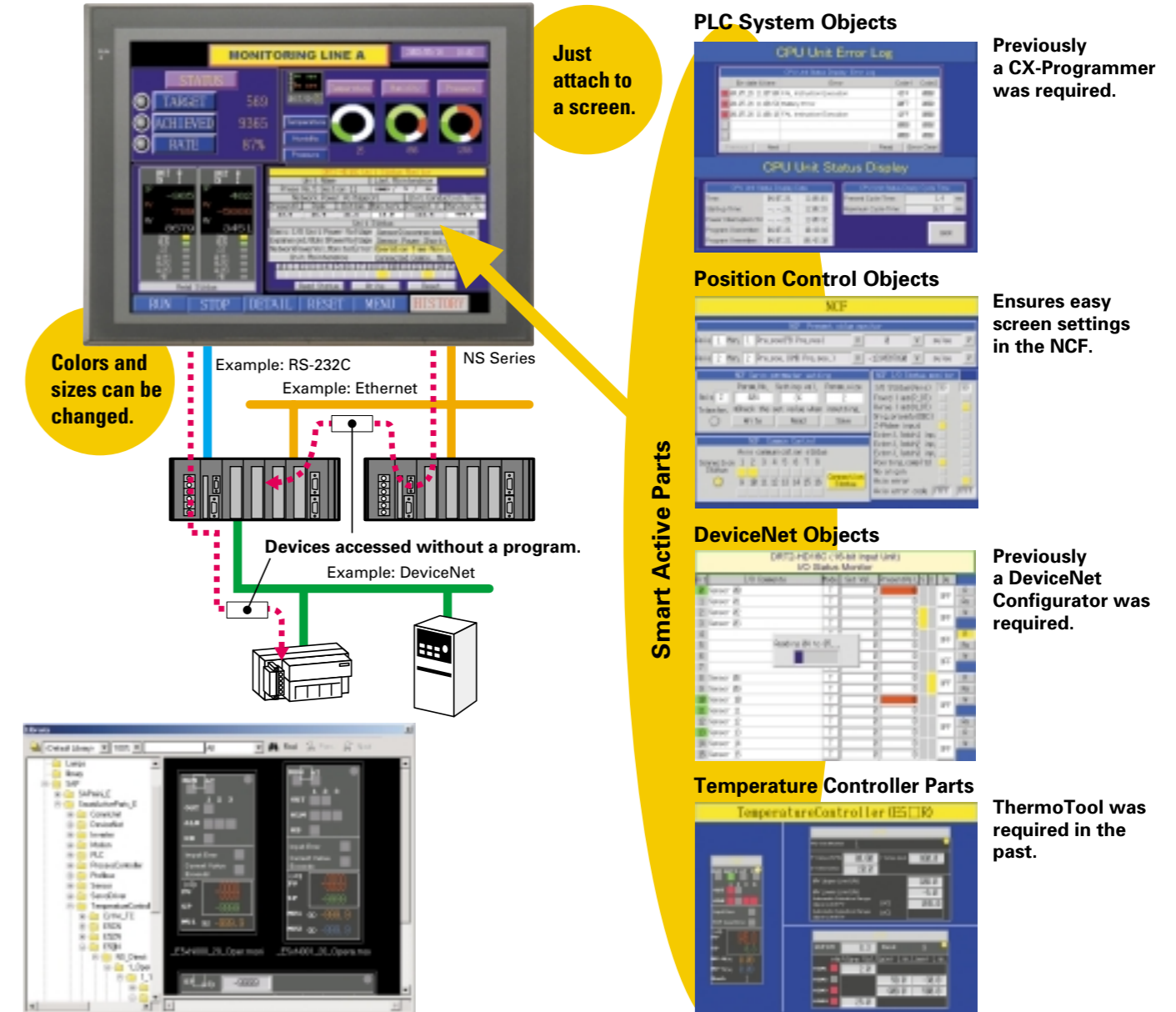

The Smart Active Parts are accessed by selecting *Tools* → *Use Library* from the menu bar of the CX-Designer.

Refer to page 15 of this catalog to see the wide variety of Smart Active Parts.

Do you have the following problems when starting the system or when errors occur?

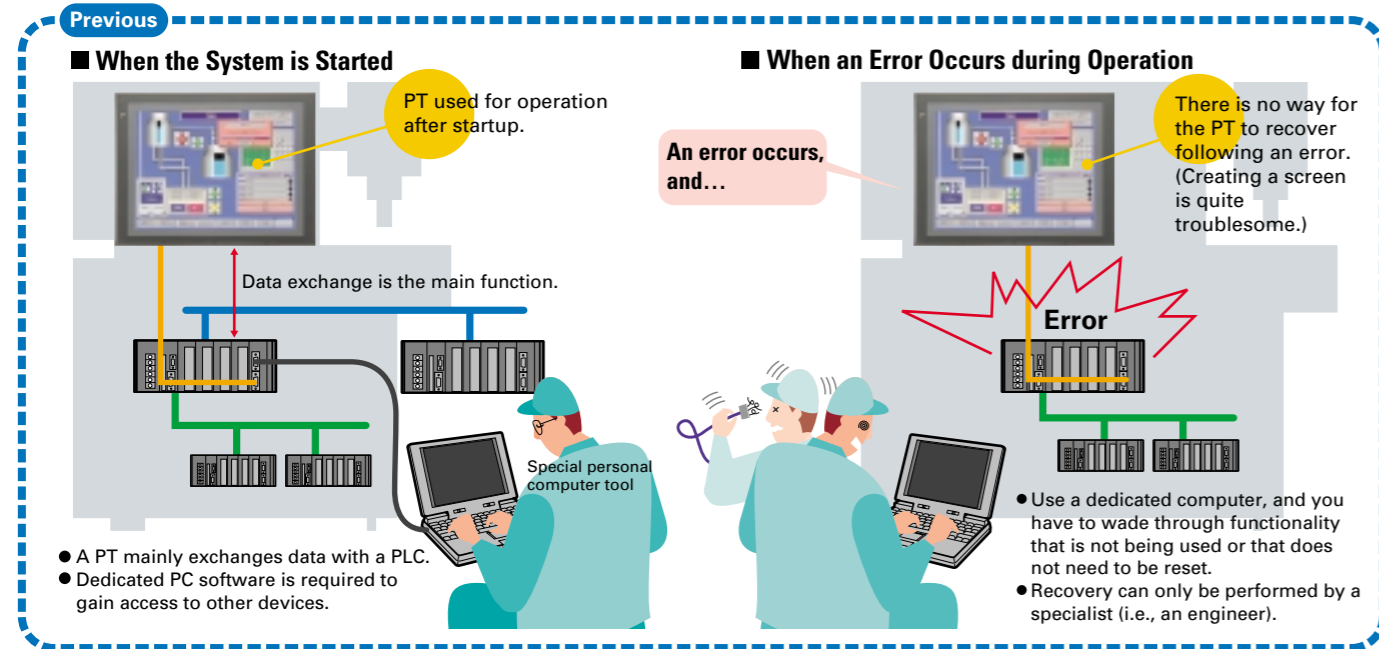

Only with NS! With the Smart Active Parts

The PT can be customized according to the specifications of the device manufacturer to optimize operation as a tool. This enables equipment maintenance by personnel other than engineers.

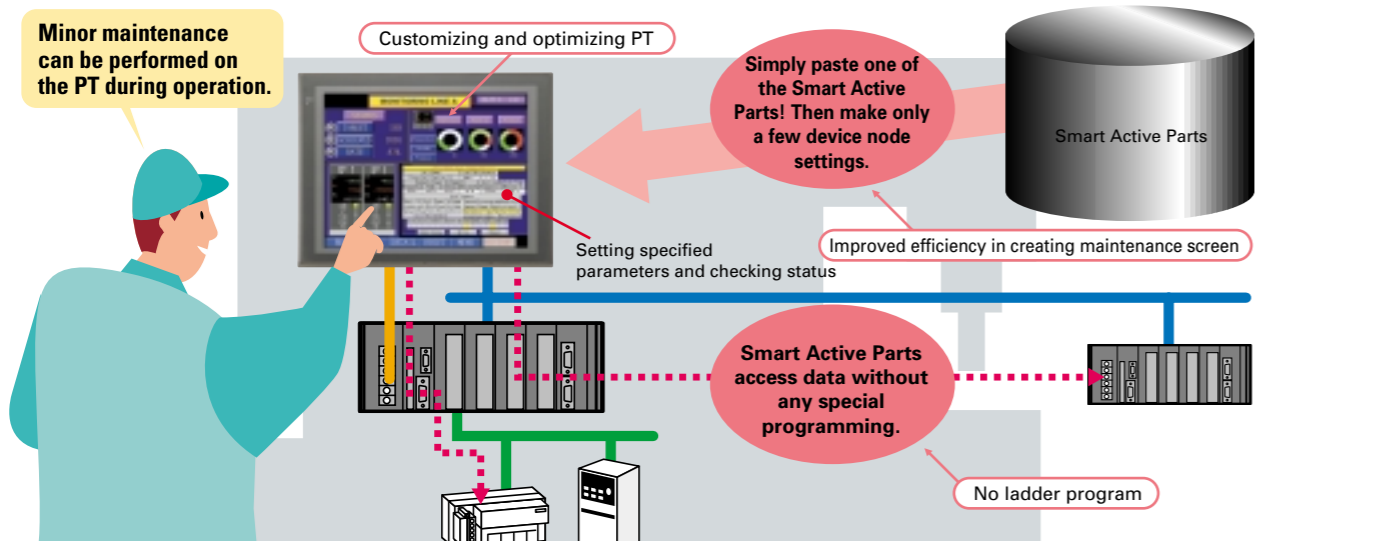

Create a screen like this as a device troubleshooter.

When an error occurs, rapid recovery is critical. With the NS Series, the following type of screen can be easily prepared to guide on-site workers to carry out the operations required for recovery.

- Display explanations of error contents and methods for recovery. (Text file direct specification)
- Use diagrams to show error locations and methods for recovery. (Bit map file direct specification)
- Display only the buttons required for recovery operations.

Error Recovery Screen Example

Text and BMP files can be directly specified, so operations such as correcting contents for recovery and replacing diagrams and photographs can be executed without requiring any special tools. For example, if the recovery operation procedure is changed by system improvements, screens can be changed by simply replacing text and BMP files, allowing for rapid implementation of improvements and countermeasures.

Note: Transfer tools must be used for transfers.

- Error contents and recovery methods are displayed.
- Error location and explanations of recovery methods can be further displayed by bit maps.
- Recovery operation screen is displayed. (Only the buttons required for operations are shown.)

Note: In addition to the Troubleshooter for the machine above, there is a PLC troubleshooter for CS/CJ-series PLCs. Contact your OMRON representative for information on Troubleshooters.

Multi-language Terminal Machine Localization with PTs

A Multi-language Input Environment Using Excel

- No special PT tools are required for translation operations.
- Translations can be requested using e-mail attachments.

Label Switching Function for Up to 16 Languages

- Devices can be started with Japanese-language screens, and then operated with screens in other languages.
- The languages can be switched to the one preferred by the device operators.

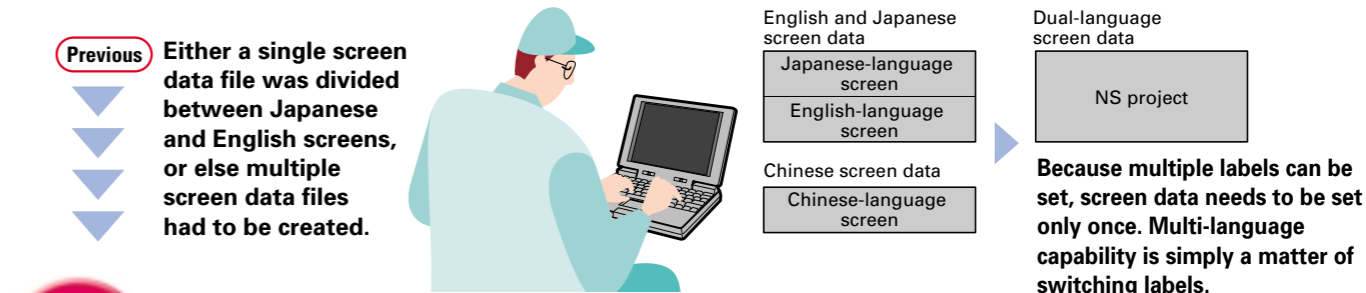

Only with NS! You can get multi-language support in Excel. Switching to as many as 16 languages is as easy as switching labels.

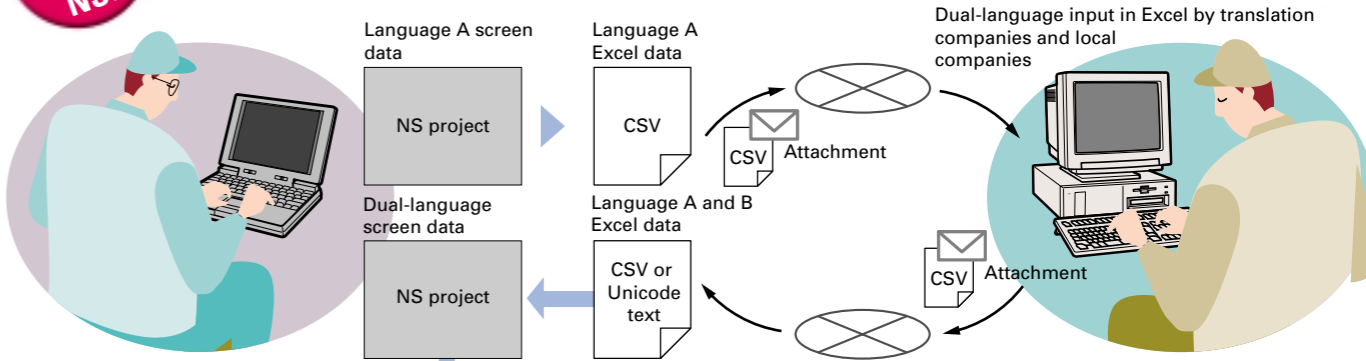

16 languages max.

Label 0

Label 1

Label 15

Only with NS!

Multi-Language PT

- Asian Languages: Japanese, Simplified Chinese (see note 1), Korean, and Traditional Chinese (see note 2)
- European Languages: English, French, German, Italian, Portuguese, Spanish, Swedish, Dutch, Finnish, Norwegian, Basque, Catalan, and Danish

Support for 17 languages

Switching to as many as 16 languages by simply switching the labels

With CX-Designer Multi-language conversion has become much easier!

Multi-language CSV data

Import

Convenient!

When importing screen data, the text attributes of user-specified labels can be applied to all other imported text. With this function, entire Japanese text attributes (e.g., MS Gothic in blue or other colors) can be used in Chinese labels. Furthermore, by using the just-fit function, long labels in English will fit within the frame limits after automatic font adjustment.

Creating Chinese, Korean, or Other Language Screens in Any Language Version of Windows

Multi-language Input (When Windows 2000 or XP is Used)



When Windows 2000 or XP is being used, Simplified Chinese (see note), Traditional Chinese (see note), Korean, and other language text can be input in CX-Designer. Select the desired language with Global IME to input a different language.

Note: Simplified Chinese: Chinese with partially simplified characters, mostly used in Mainland China.
Traditional Chinese: Chinese with traditional characters, mostly used in Hong Kong and Taiwan.

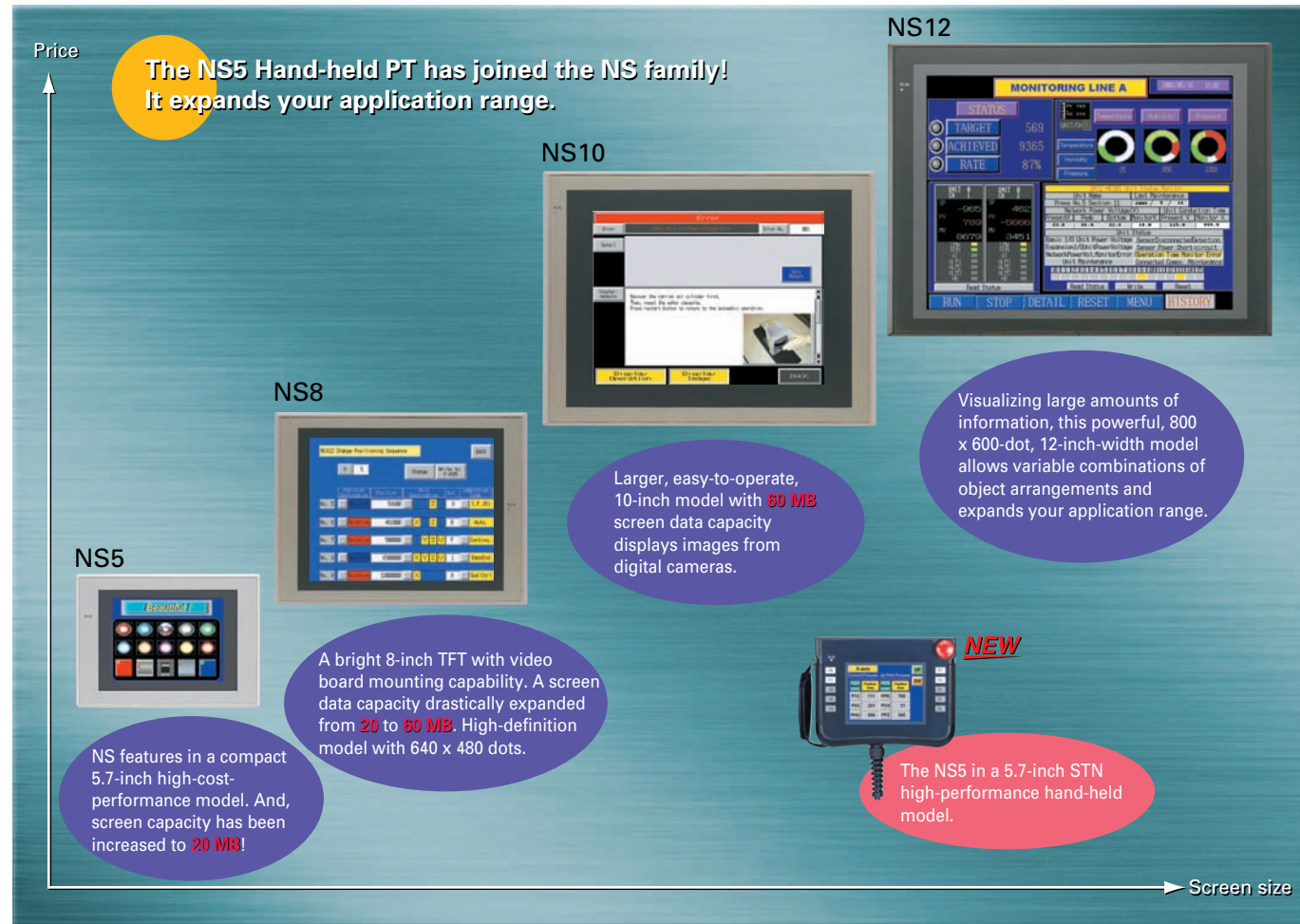
The 5-inch screen expands your application range.

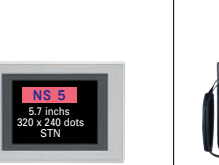

NS-series Lineup

Series	NS12	NS10	NS8	NS5	NSH5 NEW	
Appearance						
Dimensions (WxHxD)	315 x 241 x 48.5 mm	315 x 241 x 48.5 mm	232 x 177 x 48.5 mm	195 x 142 x 54 mm	223 x 176 x 70.5 mm (Not including depth of emergency stop button)	
Effective display area	12.1 inches	10.4 inches	8.4 inches	5.7 inches	5.7 inches	
Display device	TFT	TFT	TFT	TFT/STN/monochrome	STN	
Number of dots	800 x 600 dots	640 x 480 dots	640 x 480 dots	320 x 240 dots	320 x 240 dots	
Display colors	Basic colors (objects, background, etc.)	256 colors	256 colors	256 colors	256 colors	
	Image data (BMP or JPG images)	32,768 colors	32,768 colors	32,768 colors	32,768 colors/ 4,096 colors/ 16 gradations	4,096 colors
	Images displayed via video input	260,000 colors	260,000 colors	260,000 colors	—	—
Screen data capacity	60 Mbytes	60 Mbytes	60 Mbytes	20 Mbytes	20 Mbytes	
Memory Card	○	○	○	○	○	
Ladder Monitor function	○	○	○	—	—	
Video Input Unit support	○	○	○	—	—	
Controller Link Interface Unit support	○	○	—	—	—	

Version 2 Released for All NS-series Models.

NEW Greater Screen Capacity and Increased Visibility!

Create 20 MB of screens for the NS5, and an impressive 60 MB of screens for the NS8/NS10/NS12.

Models	Display device model	V 1	V 2
NS 5	MQ (monochrome)	—	20 MB
	TQ (TFT)	—	20 MB
	SQ (STN)	6 MB	20 MB
NS 8	TV (TFT)	20 MB	60 MB
NS 10	TV (TFT)	20 MB	60 MB
NS 12	TS (TFT)	20 MB	60 MB

Use digital photos to your hearts content with less worry about screen capacity.

Increased Visibility for the NS5-SQ0(B)-V2, NS8-TV0(B)-V2, and NS12-TS0(B)-V2

- NS5-SQ0(B)-V2: STN Models
Field of vision from the top increased by 15°.
- NS8-TV0(B)-V2: TFT Models
LCD increased from 8.0 to 8.4 inches and left/right field of vision increased by 5°. (External size and panel cutout are the same as previous version.)
- NS12-TS0(B)-V2: Bottom field of vision increased by 20°.

Now On Sale: The NSH5 5-inch Hand-held PT

NEW Just What You've Been Waiting for: The NS5 (STN) in a Hand-Held Model!

Hold the NS5 in the palms of your hands.

Use the Smart Active Parts Library, multi-language functionality, Programming Console feature, and all the other familiar functions of the NS5.

Function Switches
Use the ten functions switches.
F1, F2, F6, F7: Wired outputs
F3 to F5, F8 to F10: Communications outputs

Memory Card Interface and USB Slave Connector.
Easily transfer screens or save logs at high speed using a USB connection.

Emergency Stop Switch.
3PST-NC Structure
DPST-NC: Increase safety (wired outputs).
SPST-NC: Input to internal NSH5 memory, output to a lamp for emergency stop switch operation, or output via communications, e.g., to a PLC.

Water Resistance to IP65
The water-resistant structure is equivalent to IP65 on all surfaces.

PT and Cable Sold Separately
Select the Cable according to the application (RS-232C/RS-422A). Connector-loose wires, UL connector, 3 m or 10 m.

3-Position Enable Switch
Increased safety with DPST-NO structure (wired outputs).

Superior Shock Resistance
Consistent with JIS B 3502, IEC 61131-2 (drop shock).

cULus certification is scheduled for the near future for the NSH5 5-inch Hand-held PT.

New functionality added in Ver. 6 extends the ease of use of the NS-series PTs.

Smart Active Parts greatly reduce the number of drawing and programming steps. PT System Ver. 6 or Higher

Drastically reduce your programming and development time.

- Want to check an error or adjust settings without any software tools. But realization of Touch screen and PLC program are really time consuming.
- Also, it is dangerous to use software tools since they can do anything. Isn't it possible to show or set one only part of the information?

Solution

Tool Functions Provided with Smart Active Parts

- All you need to do is select the required Smart Active Part in the CX-Designer and drag & drop it on the screen see page 5).
- Smart Active Parts not only reduce the number of screen drawing and ladder programming steps, but they also eliminate the need to debug.
- Software functions are achieved on the screen without software such as the CX- Programmer, CX-Position, and DeviceNet Configurator.

Make PID settings for temperature control without connecting software.

As a setting device for temperature control

See the error log of the PLC without connecting software.

Only one single part is on the screen!

Only three parts are on the screen!

Refer to page 15 of this catalog to see the wide variety of Smart Active Parts.

Easy screen transfer from anywhere at higher speed. PT System Ver. 6 or Higher

High-speed screen transfer through USB.

- Most computers now have a USB port, and no serial RS-232C ports are provided.
- You may want to transfer screens more easily at higher speeds.

Note: Lot number 0325 or later is required for USB screen transfer with NS-V1 models.

Solution

Data can be transferred over USB through a single cable between the computer and PT. No devices for serial RS-232C and USB conversion are required. Moreover, USB allows high-speed screen transfer by just connecting the cable.

Screen transfers equivalent to Ethernet.

Screen transfers using Memory Cards are possible from the maintenance menu.

- It is very convenient to make backups without using a computer. It is, however, troublesome to operate a DIP switch on the back of the PT each time backups are required.
- You may want to make backups periodically, but worry because the DIP switch pins may break.

Solution

Screen transfers using Memory Cards are possible from the maintenance menu. No physical switch operations are required on the rear panel. Furthermore, easy operation is ensured with no wear and tear of hardware, including the switch.

Select from the system menu.

Start downloading/uploading.

Screen transfer through modems is now possible.

- Even a single screen change in a shipped machine involves a risk, because a screen sent by e-mail needs to be transferred to a person familiar with operation. Training workers to understand operation is a hard job. Or service personnel need to visit the site to change screens.

Solution

The screens can be transferred from a computer in an office through modems. The maintenance of the screens is possible without touching the device. Therefore, no training or engineer visits are required.

RS-232C Modem

Modem

Improved Data Logging PT System Ver. 6 or Higher

Number of logging points greatly increased.

For example, the PT can log data at 2-second intervals 24 hours a day (for a 43,200-point log).

- The number of Always Log points has increased from 1,000 to 50,000 max. per line.
- The total number of Always Log points increased from 5,000 to 50,000.

- Example:
- Logging 1 word and 1 address at 1-second intervals: 50,000 points, with 50,000 logging points per line. **50 times**
 - Logging 1 word and 3 addresses at 1-second intervals: 50,000 points, with 16,666 logging points per line. **10 times**

The number of logging points for one line depends on the number of logging words and the number of logging addresses. For details, refer to the manual.

Logging continues.

For example, you may want to log data at 2-second intervals 24 hours a day (a 302,400-point log). This is possible with the NS Series.

- When the logging data reaches the number of preset logging points, the logging data can be automatically saved in a Memory Card in CSV format. After automatic saving, the logging data will be cleared. Therefore, it will be possible to continue logging. (The Memory Card can hold a maximum of 1,000 files.)

Example:

- Example: Logging 1 word and 1 address at 2-second intervals with the number of logging points set to 43,200 (i.e., at 2-second intervals for 24 hours a day).

Auto-matically saved

Memory Card 64M

LOG001.CSV 04/06/04 10:00
LOG002.CSV 04/06/05 10:00
LOG003.CSV 04/06/06 10:00
LOG004.CSV 04/06/07 10:00
LOG005.CSV 04/06/08 10:00
LOG006.CSV 04/06/09 10:00
LOG007.CSV 04/06/10 10:00

Logging data for each day (43,200 points) is saved in the Memory Card in CSV format.

It is possible to make a one-week log by automatically saving the data seven times.

Suffixes are automatically added to file names set in the CX-Designer.

Past logs can be seen.

You may want to see logs saved in the past in a Memory Card on the screen. This is possible with the NS Series.

- Log data in a Memory Card can be read on the screen with the read file button. A list of files with time stamps will appear on the screen. By selecting the desired file, the past log in the Memory Card can be read.

Read file button

The log data files in the Memory Card appear as shown below when the read file button is pressed.

Standard data can be displayed in the data log.

You may want to save the present log data as standard data in the Memory Card. This is possible with the NS Series.

- By pressing the save to file button, the displayed log data can be saved in the Memory Card in CSV format. The saved log data can be overlapped as standard data on the screen by pressing the read file button. By turning the log start address ON and OFF, logged data can be controlled to enable/disable logging.

Save to file button

Read file button

Log start address

Standard data

NS-V2 Hardware Means High Quality, High Performance, and High Capacity

Beautiful

High definition
Displays image data (BMP and JPG) beautifully.

Model	Colors
NS5	4,096 colors
NS8	32,768 colors
NS10	32,768 colors
NS12	32,768 colors

NS-V2: 32,000 colors

Note: NS5-SQ0(B)-V2: STN models have 4,096 colors. NS5-TQ0(B)-V2: TFT models have 32,768 colors.

Large

Large-capacity image data
Three times the image data capacity for standard models

Model	V1	V2
NS5	6 MB	20 MB
NS8	20 MB	60 MB
NS10	20 MB	60 MB
NS12	20 MB	60 MB

NS8/10/12-V1 20 MB

NS8/10/12-V2 60 MB

Printer Support

USB port compatibility with commercially available printers

Hard copies of screens can be printed out in color by USB-compatible printers.

USB port included as standard equipment

General printer compatible with USB port

USB cable

Model	Support
NS5	Not Supported
NS8	Supported
NS10	Supported
NS12	Supported

•Manufacturer: EPSON or Canon
•Recommended models
EPSON: PM-2200C, PM-930C, PM-870C, PM-740C, PM-900C, PM-D600, PM-G730, PM-G730, PX-A650, PM-G730, PM-D600, PX-A650
Canon: BJ-M70, BJ-M40, PIXUS550i, 50i, 80i, IP2000, IP3100, IP4100, IP4100R, IP90

EPSON and Canon printers supported.

Faster

Faster drawing speed
High-speed screen switching

Model	Support
NS5	See note.
NS8	Yes
NS10	Yes
NS12	Yes

Note: The NS5 uses a different graphic controller from other models.

200-MHz RISC CPU
High-speed graphics controller

The NS Series is more beautiful and user-friendly.

More beautiful

You can make beautiful screens with simple operations.



Windows fonts can be used for switches and lamps



● Auto font resizing function
Automatically resizes fonts to the object size. No need to adjust font sizes manually anymore!
Furthermore, just-fit font size adjustments have been possible since version 6.



● Beautiful BMP Parts Collection has been newly added. Simply select the desired part, paste it on your screen, and make your screens neat!



● 32,768-color display
The color variation displays pictures brilliantly!

More user-friendly

You can partially replace text and pictures from your computer.

● FTP (File Transfer Protocol) has been added! Texts, lists, and recipes can be replaced with the put/get command from your computer! You can even replace BMP files from your computer easily.

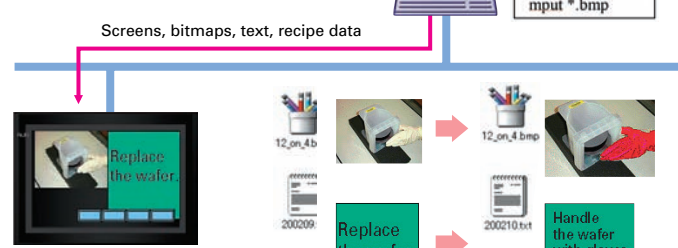

More strength in applications

The NS can be connected to a Board PC. The NS can also be directly connected to an OMRON Temperature Controller.

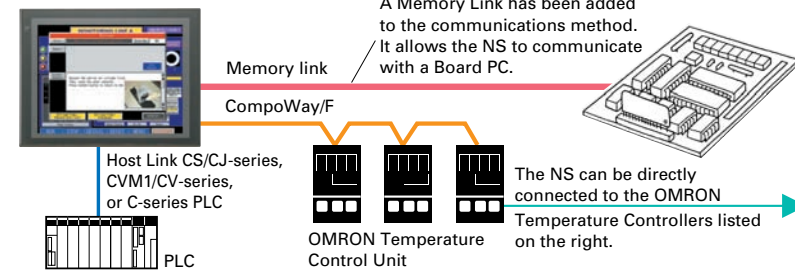

The following models, which have an RS-485 communications port and support CompoWay/F communications, can be connected to the NS.

Unit	Series and Models	Unit	Series and Models
Modular Temperature Controllers		Temperature Controllers	
E5ZN	E5ZN-SCT24S (Terminal Unit)	E5AN/EN Series	E5AN-□□□□ Thermocouple input
E5AR	E5AR-□□□□-FLK	E5AN Series	E5AN-□□□□ Temperature-resistance input
E5ER	E5ER-□□□□-FLK	E5EN Series	E5EN-□□□□ Thermocouple input
		E5EN Series	E5EN-□□□□ Temperature-resistance input
		E5AN Series	E5AN-□□□□ Temperature input
		E5EN Series	E5EN-□□□□ Analog input
		E5AN Series	E5AN-□□□□ Analog input
		E5EN Series	E5EN-□□□□ Thermocouple input
		E5EN Series	E5EN-□□□□ Temperature-resistance input
		E5EN Series	E5EN-□□□□ Temperature input
		E5EN Series	E5EN-□□□□ Analog input
		E5GN Series	E5GN-□□□□ Thermocouple input
		E5GN Series	E5GN-□□□□ Temperature-resistance input

System Configurations

Various connections, such as 1:1, 1:2, 1:N, and M:N, are supported with Ethernet or serial connections.

PT:PLC = 1:1



PT:PLC = 1:2

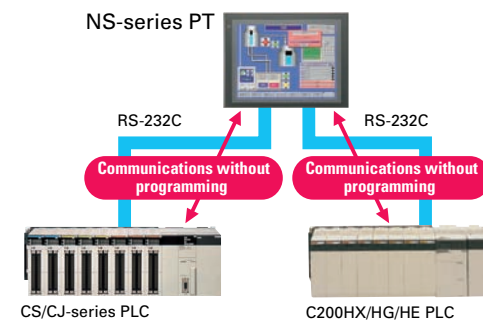

PT:PLC = 1:N

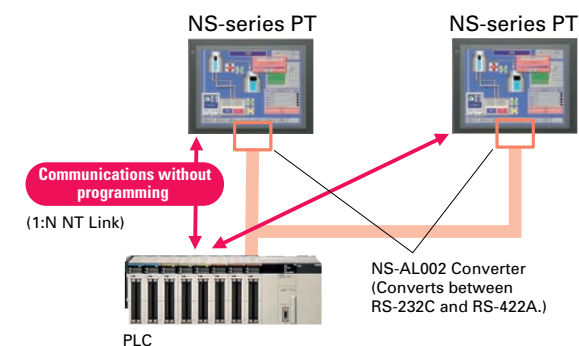

Host Registration Function

It is possible to register two or more PLCs as hosts and communicate with the PLCs by specifying the host ID and address when connected via Ethernet or Controller Link.

PT:PLC = M:N

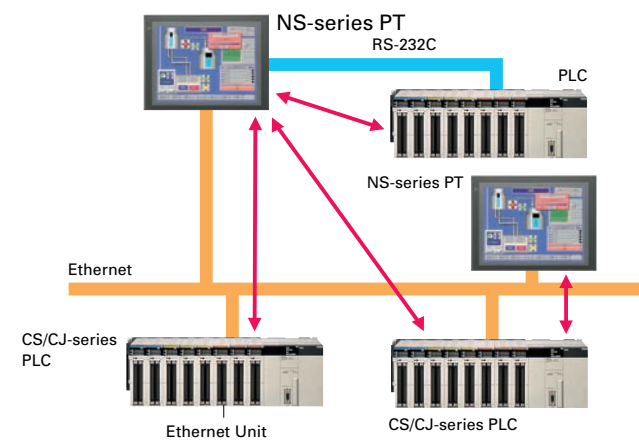

Powerful Networking

Exchanging Data with a PLC over a Network (Multihost)

Communicating with a PLC via NT Link, using Ethernet without Special PLC Programming

Ethernet Communications without Programming

NS-series PTs can communicate with a CS/CJ-series PLC (equipped with an Ethernet Unit) through "program-free" communications just like NT Link communications. Data is transferred through Ethernet through a simple PLC address and initial communications setup.

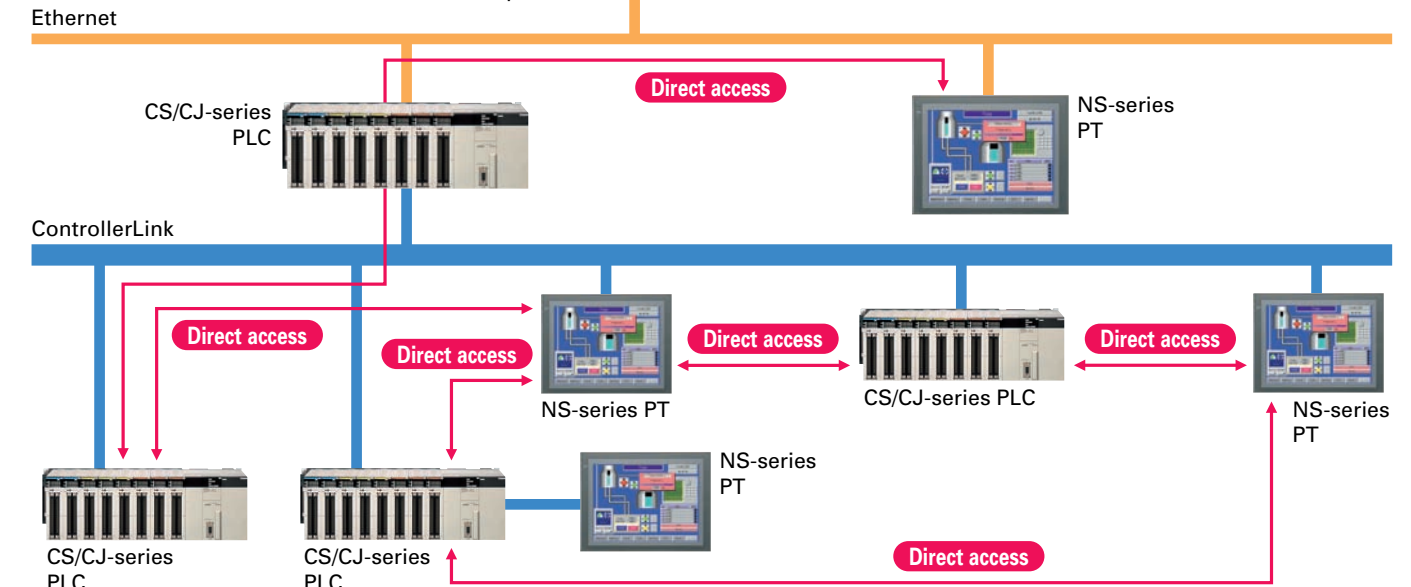

Using Data Links between the PT and the PLC

Controller Link Interface Unit

The Controller Link is an FA network that can send and receive large data packets flexibly and easily among OMRON PLCs and IBM PC/AT or compatible computers. The NS12 and NS10 PTs can be connected to the Controller Link network easily via a Controller Link Interface Unit. When a Controller Link network is used, data can be transferred between multiple PLCs and NS12/NS10 PTs without writing ladder programming to manage the communications.

SPMA (Single Port Multi Access) Function

Screen data can be transferred through the PLC from the CX-Designer to the PT connected to the PLC in series or via a network.

You may want to transfer screens to a PT through the PLC without changing computer connections or to transfer a ladder program to the PLC through the PT by using the Ethernet or Controller Link.

Ladder programs can be monitored or transferred from the CX-Programmer through the NS-series PT to PLCs connected to the PT in series or via a network.

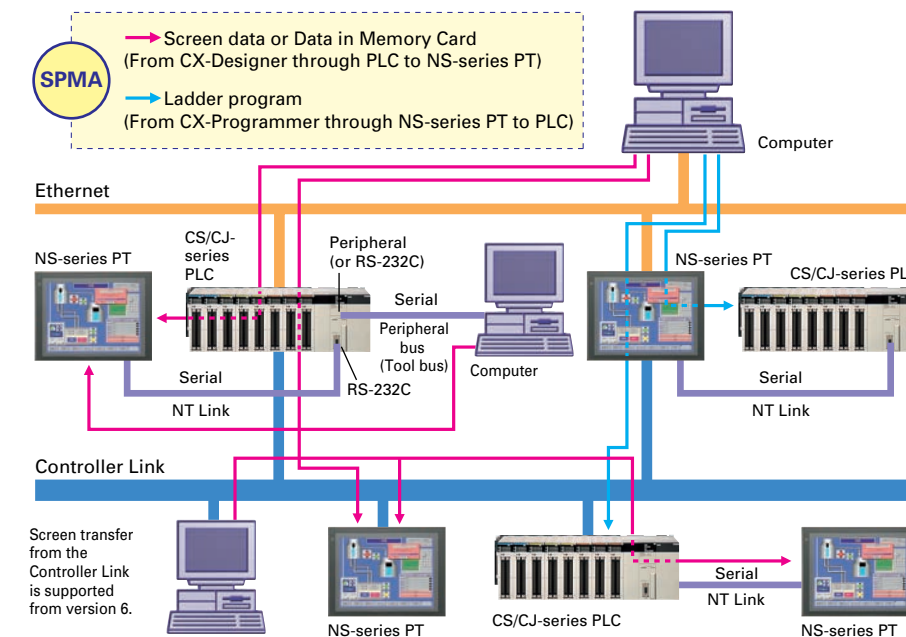

* To use the SPMA function through the PLC, the following software and hardware versions are required.
 ● NS-series PT: System version 3.0 or higher
 ● NS Designer: Version 3.0 or higher or CX-Designer: Version 1.0 or higher
 ● CX-Programmer: Version 3.1 or higher
 ● PLC: Lot No. 030201 and later (Refer to the following table.)

PLC series	CPU model	Lot number
CJ Series	CJ1H-CPU65H	030201
	CJ1H-CPU66H	
	CJ1G-CPU42H	
	CJ1G-CPU43H	
	CJ1G-CPU44H	
	CJ1G-CPU45H	
	CJ1M-CPU11	
	CJ1M-CPU12	
	CJ1M-CPU13	
	CJ1M-CPU21	
CS Series	CJ1M-CPU22	030201
	CJ1M-CPU23	
	CS1H-CPU63H	
	CS1H-CPU64H	
	CS1H-CPU65H	
	CS1H-CPU66H	
	CS1H-CPU67H	
	CS1G-CPU42H	
	CS1G-CPU43H	
	CS1G-CPU44H	
CS1G-CPU45H		
CS1D-CPU42S		
CS1D-CPU44S		
CS1D-CPU65S		
CS1D-CPU67S		

Using Video Inputs

The NS-CA002 has joined the NS-CA001 Video Input Unit.

You may want to input moving images from a video camera or the image output from a Vision Sensor, arrange them on the PT screen, and capture (save) the images or display the capture data on the PT.

Display PC Screens with the NS-CA002

NS-CA002 RGB/Video Input Unit (Supported by the NS12-V□/NS10-V□/NS8-V□.)

An analog RGB input terminal is provided in addition to two video input interface terminals. A single video or analog RGB display is possible on the NS-series PT. In that case, video display is possible in user-defined positions and sizes. Touch switches and parts, such as lamps, can be overlapped on the video display. The display of parts will not disappear.

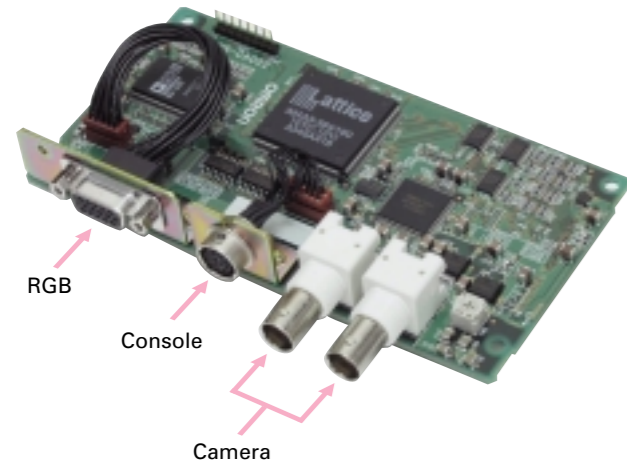

Note: Two video signals cannot be simultaneously input to a single screen.

NS-CA001 Video Input Unit (Supported by the NS12-V□/NS10-V□/NS8-V□.)

Four video input interfaces are provided, so four video or CCD cameras can be connected. Up to four images can be displayed simultaneously if the image size is 320x240 pixels.

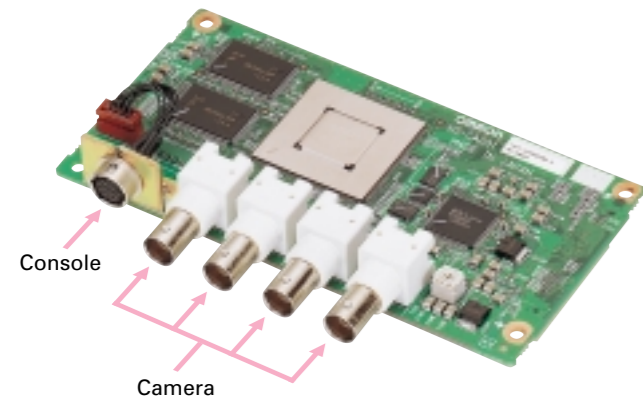

Saving Displayed Video Images to a Memory Card in BMP Format

Image Capture Function

When necessary, the displayed image can be captured and saved in a Memory Card in BMP format. The saved image can then be uploaded from remote personal computer via Ethernet or Serial connection.

The number of images that can be saved depends on the capacity of Memory Card. As an example, about 50 images from a 640x480 display (about 600 Kbytes each) can be saved in a 30-Mbyte Memory Card.

Image capture data read function PT System Ver. 6 or Higher

BMP data captured and saved in a Memory Card can be read on the PT. BMP data displayed in thumbnails can be selected and displayed on the captured data display screen that will appear for the command button.

If an error occurs, the image when the error occurred can be displayed on the NS screen. This is useful for on-site error analysis.



The NS monitors machine status for who and how machines are managed to help speed recover from problems.

Monitoring and Setting PLC Data

For Operators

Display machine status simply.

Do not want to be aware of ladder programs and PLC memory areas. Only want to display I/O comments and I/O status.

Solve with the Switch Box function

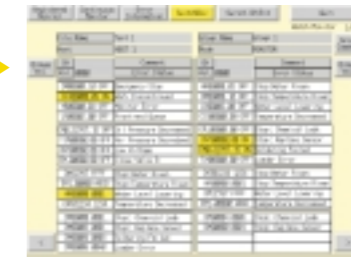

Easily Displaying the Status of Particular Bits in Ladder Programs when Errors Occur

Switch Box Function

The Switch Box Function has been added to the NS-series Programmable Terminals. The Switch Box Function can be used to monitor the status of each bit in a word or a combination of user-selected bits organized like a ladder program section. The Switch Box Function makes it possible to perform basic troubleshooting on the factory floor even without a computer.

Display PLC memory areas without using tools.

Want to display and change the PLC memory areas without showing the PLC program.

Solve with the Device Monitor function

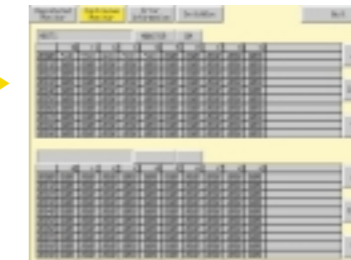

Monitoring PLC I/O Data for the Purpose of Device Debugging and Maintenance

Device Monitor Function

The Device Monitor Function is a standard feature in the NS-series Programmable Terminals. Data in the PLC's I/O memory can be accessed directly (read and written.) The Device Monitor provides functions that can significantly reduce the time needed to set up the system, such as displaying a block of consecutive PLC data area addresses and inputting/verifying parameters in CPU Bus Units and Special I/O Units.

Display program without using tools

Want to identify the fault location by checking the actual PLC program. Want to change part of the program, a timer/counter, without connecting tools.

Solve with the Ladder Monitor function

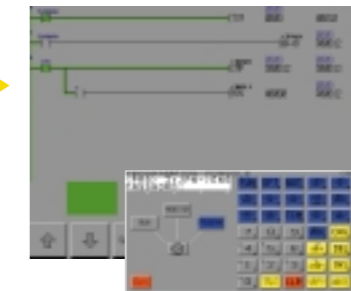

Monitoring Execution of the PLC's Ladder Program

Ladder Monitor Function

(NS12-V□/NS10-V□/NS8-V□)
The Ladder Monitor Software provided with the CX-Designer can be used to monitor states, search for addresses and instructions, and monitor multiple I/O points at the same time in CS/CJ-series PLCs ladder programs via a serial, Controller Link, or Ethernet connection. Copy the Ladder Monitor software to a Memory Card and install the Memory Card in the NS-series PT to enable these monitoring and searching operations. It is also possible to display I/O comments created with the CX-Programmer using an I/O Comment Extract Tool.

From CX-Designer version 1.0, the Ladder Monitor software is stored in the following folder on the CD-ROM. Copy it to a Memory Card (sold separately) to use it.
CX-One Disk 3: \Utility\CX-Designer\English\LadderMonitorFunc.
CX-Designer CD-ROM: \Utility\English\LadderMonitorFunc.

For Experts

Facilitate Equipment Maintenance

Integrating Special Unit Functions or Component Peripheral Tool Functions into PTs

Smart Active Parts

The following Smart Active Parts are provided and can be installed on the NS-Designer (version 6 or higher).

- **For CS/CJ AND CS1D CPU Unit**
Error Log Monitor, Online Battery Change Button, etc.
- **For Serial Communications Boards/Units**
Communications Status Displays (Error Monitor), Ports Settings, etc.
- **For Ethernet Units/CLK Units**
Network Status Displays (Error Monitor and Network Node Status), etc.
- **For MC/MCH Unit**
JOG Running, Search Zero Position, Program Running, Error Displays, I/O Status Monitor, PV Monitor, etc.
- **For NC/NCF Unit**
JOG Running, Direct Running, Memory Running (NC Only), Error Displays I/O Status Monitor, PV Monitor, etc.
- **Wireless Terminals for WT30**
Monitoring Slave Operating Status in a Wireless Environment
- **For Servo (R88D-WT, R7D-AP)** (See note.)
PV Monitor, Parameter Settings, Error Displays, Driver Information Displays, I/O Status Monitor, etc.
- **For Inverters (See note.)**
Rotation Speed/Monitoring Output Frequency, Other Parameter Settings, etc.
- **For DeviceNet**
DRT2 Maintenance/Status Information, IN/OUT Information, etc.
- **For Temperature Controllers (E5□R, E5ZN, E5□N and CJ1W-TC)**
Run Monitor, PID Settings SP Settings, Alarm Settings, Input Correction Settings, etc.
- **For Sensors (E3X-DRT)**
Threshold Settings, Monitoring Light Reception Levels, etc.
- **For the SmartSlice GRT1 Series**
Communications Unit Status, Warning/Alarm Flags, Network Joining/Leaving Status

Note: Smart Active Parts require a Serial Communications Units/Boards (version 1.2 or later).

Using a Personal Computer to Check PT Operation

Using a Personal Computer to Check the Operation of Created Functional Objects

Simulation via the "Test Function"

When a test is started, a test screen and virtual PLC will be displayed on the computer.

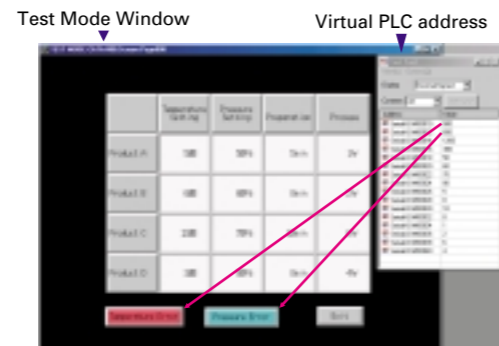
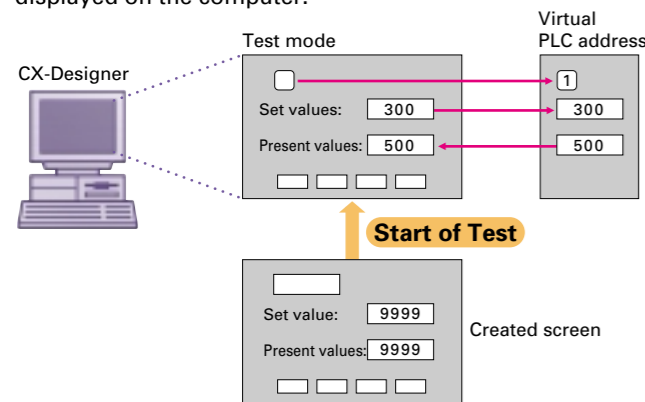

Operating (clicking with the mouse) the functional objects on the test screen will change the corresponding address in the virtual PLC. Conversely, changing the content of a virtual PLC address will change the corresponding functional objects. It is also possible to confirm pop-up screens. This function can be used to confirm the actual operation of a screen during the editing. The test function enables debugging screens without NS and PLC Hardware.

Transferring Screen Data to the PT On-site from a Memory Card

Memory Card: Upload/Download Function

It is possible to download the screen data and system program to Memory Card and upload the same data from the Memory Card. It is also possible to automatically upload the data from the Memory Card to CX-Designer or automatically download the data from Memory Card to PT when the power of PT is turned ON.

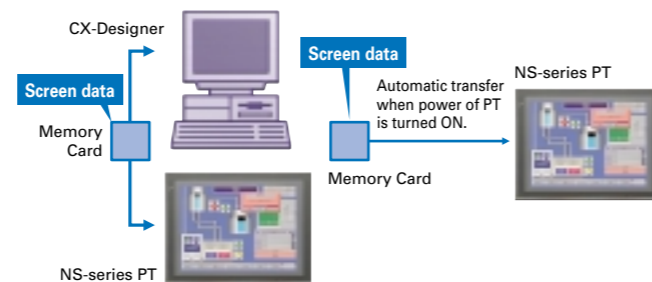

Using General Software

Setting Functional Object Properties in Excel

CSV File Input/Output

The property settings for each functional object can be exported in CSV format. The settings data can be imported again after it has been edited with a program such as Excel.

Editing Text and Bitmap File with Your Favorite Text Editor

Editor Specifying Function

The user can select the editor when editing text or bitmap files.

Creating System-related Documents

Outputting Project Information in RTF

Data such as screen information and object information can be output in an RTF file. The RTF file can be read into Word Processor to produce a system manual.

Example of an RTF File Read into Word Processor

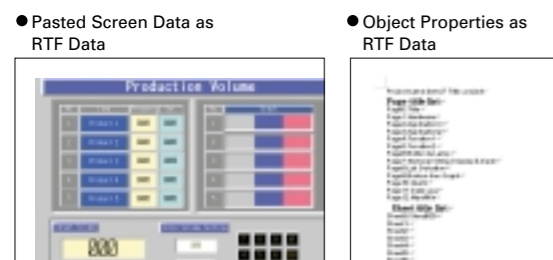

Using Excel to Analyze Data, Such as the Alarm/Event History, Operation Log, and Error Log, and to Create Daily Reports

Memory Card: Data Logging Function

Logging data (trend data, up to 50,000 points with a sampling cycle of 0.5 or 1 to 86,400 s/group) can be stored in the Memory Card in CSV format.

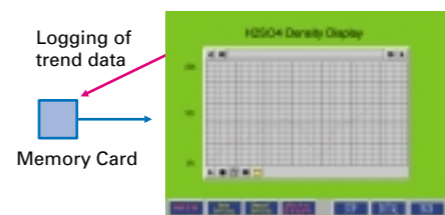

Using Excel to Analyze Time-series Data and to Create Daily Reports

Memory Card: History Storage Function

The following data can be saved to the Memory Card in CSV format.

- Alarm/Event History (Alarm/Event history data)
- Operation Log (Screen operation history data)
- Error Log (Error log data recorded during macro program execution)

High-reliability and Advanced Functions in the Industry's Slimmest PT

Super-thin 48.5-mm Body for a Slimmer Control Panel

This thin-profile model has few protrusions so it can be incorporated easily into a panel or machine. The PT can help save space when space is at a premium.

• NS12, NS10

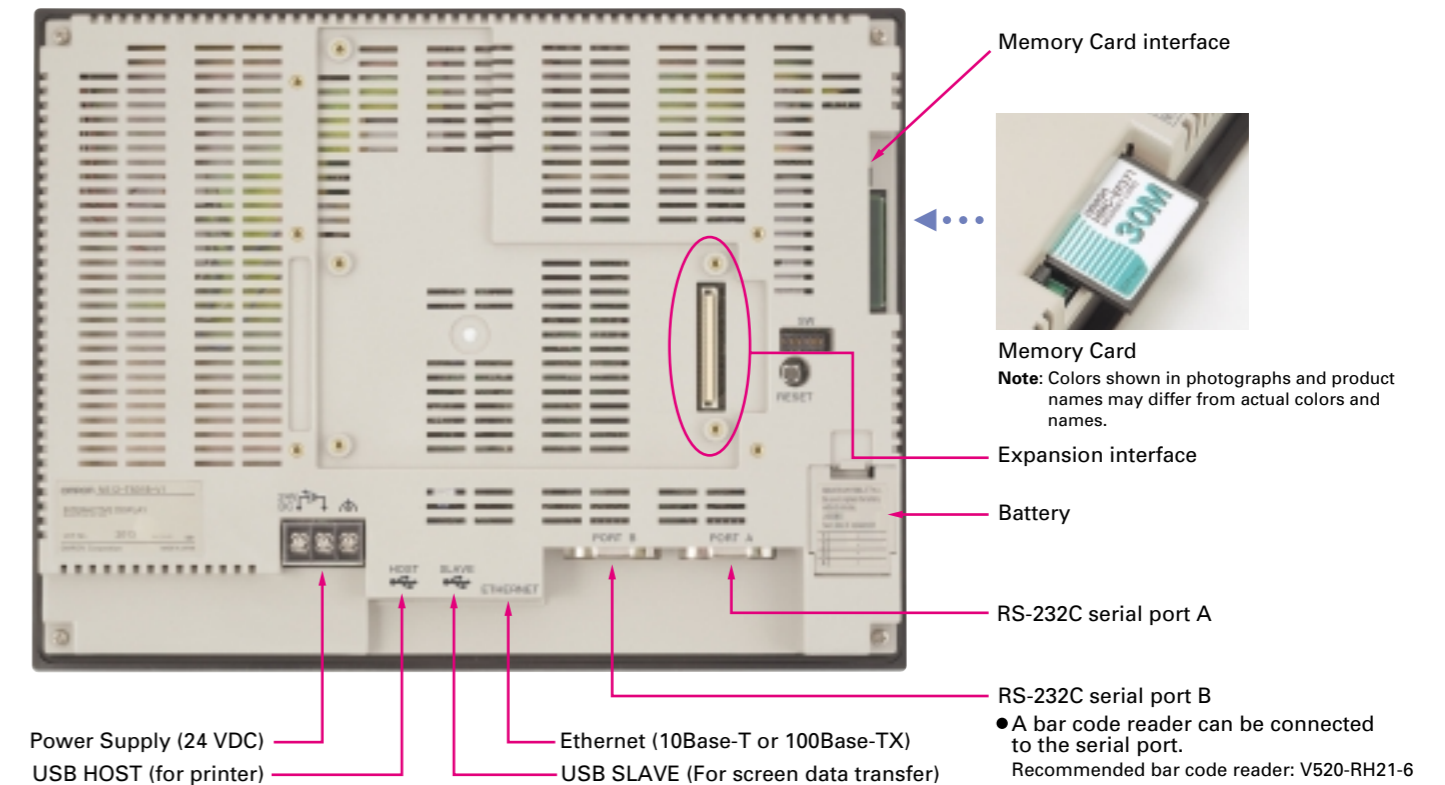

• NS8

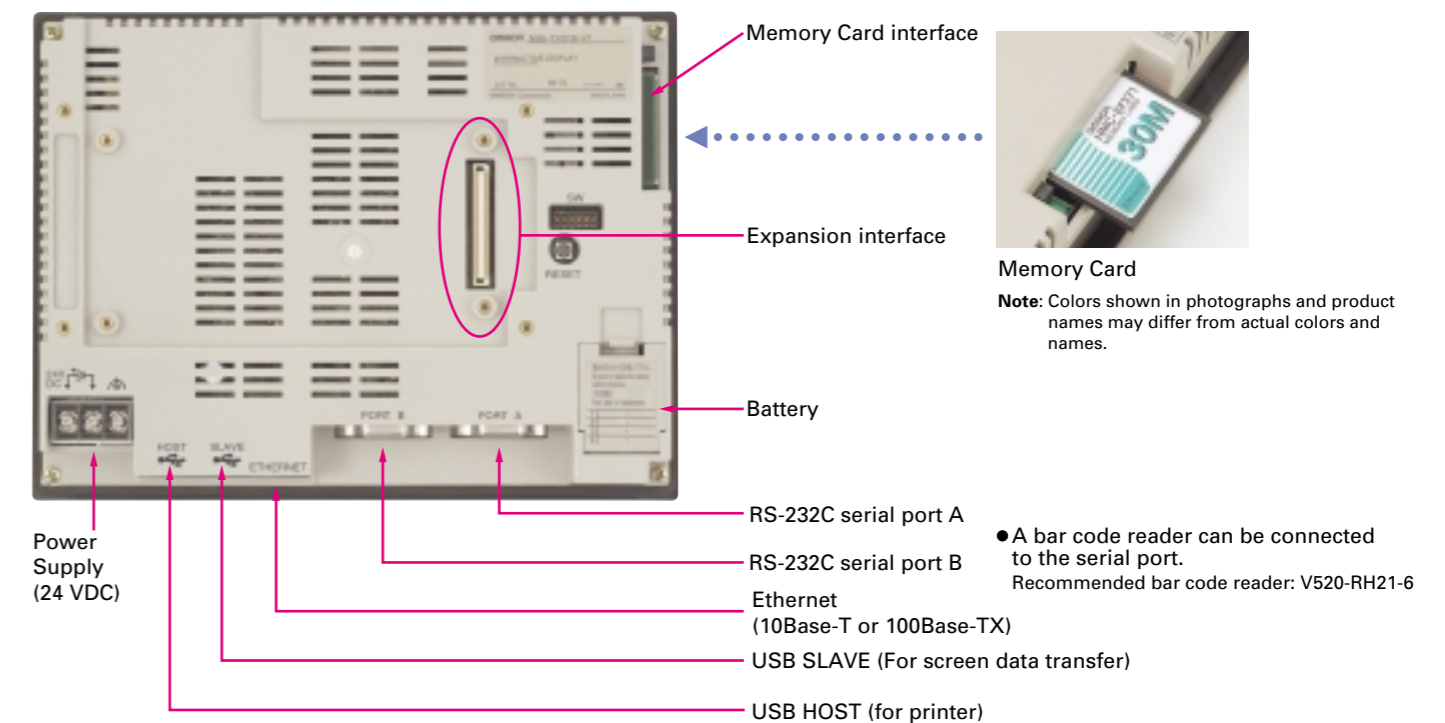

Built-in Expansion Interface

The NS-series PTs have a built-in Expansion Interface for future expandability.

USB Ports

A printer can be connected to the USB HOST port. Refer to *Printer Support* on page 10 for recommended printers.

● NS5

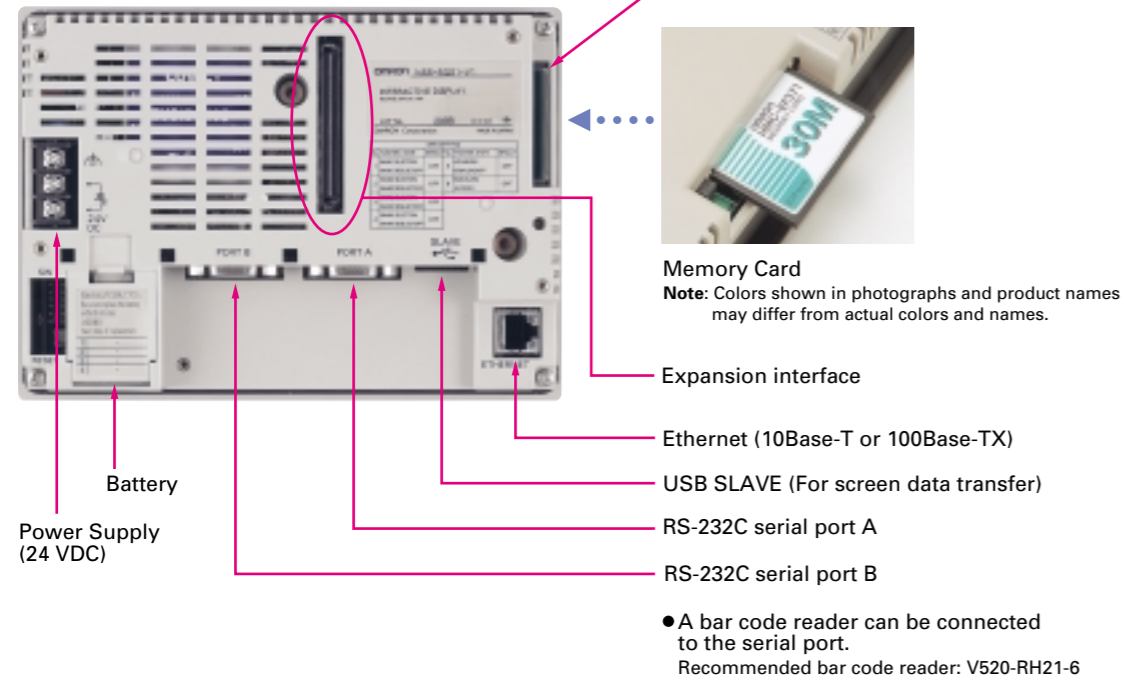

Optional Products

Video Input Unit
NS-CA001(with Cover)



RGB/Video Input Unit
NS-CA002 (with cover)



Controller Link Interface Unit
NS-CLK21 (with Cover)



RS-422A Adapter
CJ1W-CIF11

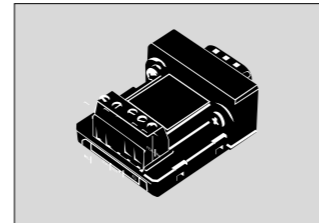

RS-232/RS-422A Conversion
Unit NS-AL002



Communications Cable
XW2Z-S002



Protective Cover/Anti-reflection
Sheet for NS-series PT
NS□-KBA0(N)
NT30/NT31C-KBA05(N)

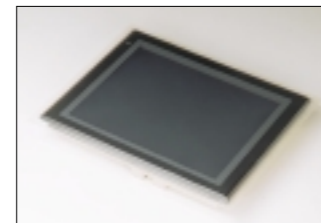

USB Serial Conversion Cable
CS1W-CIF31



Note: Colors shown in photographs and product names may differ from actual colors and names.

Dimensions

■ NS12/10 PT Units: mm

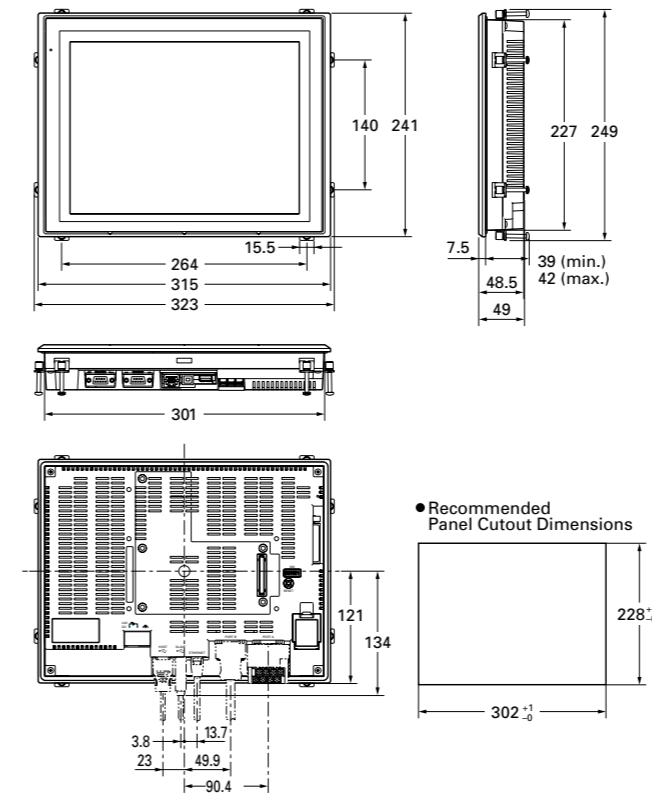

■ NS8 PT Units: mm

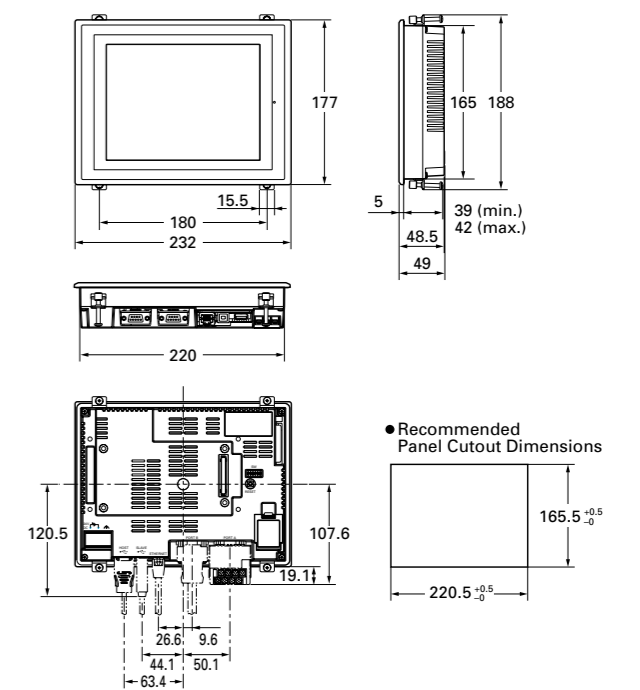

■ NS5 PT Units: mm

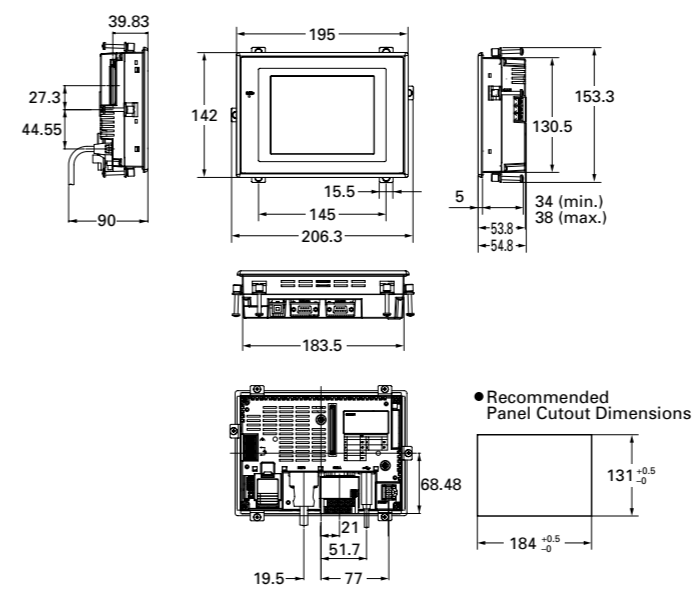

■ NS5 Hand-held PT Units: mm

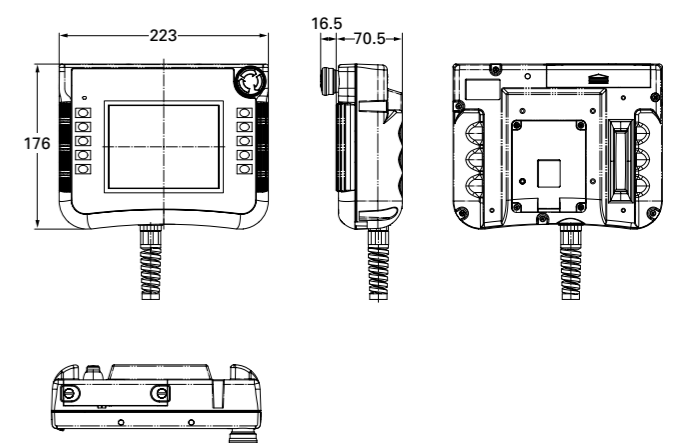

■ NS-CA001 Video Input Unit
Units: mm

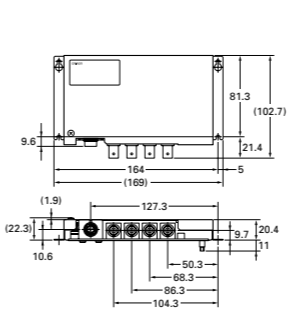

■ NS-CA002 Video Input Unit
Units: mm

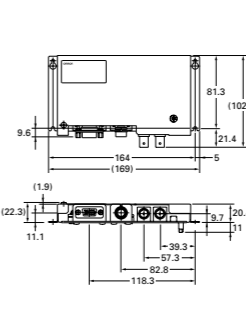

■ NS-CLK21
Controller Link Interface Unit
Units: mm

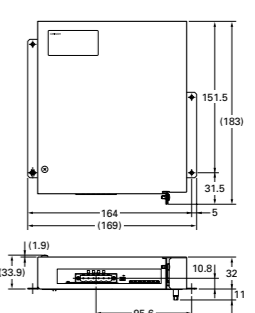

Performance / Specifications

General Specifications

NS12/NS10/NS8/NS5-V2

Item	Specifications
Rated power supply voltage	24 VDC
Allowable voltage range	20.4 to 27.6 VDC (24 VDC ±15%)
Power consumption	25 W max. (15 W max. for the NS5)
Ambient operating temperature	0 to 50°C (See notes 1 and 4.)
Storage temperature	-20 to 60°C (See note 2.)
Ambient operating humidity	35% to 85% (0 to 40°C) with no condensation 35% to 60% (40 to 50°C) with no condensation
Operating environment	No corrosive gases.
Noise immunity	Conforms to IEC61000-4-4, 2 kV (power lines)
Vibration resistance (during operation)	Conforms to JIS C0040. 10 to 57 Hz, 0.075 mm amplitude, 57 to 150 Hz, 9.8 m/s ² 30 min each in X, Y, and Z directions
Shock resistance (during operation)	Conforms to JIS C0041. 147 m/s ² 3 times each in direction of X, Y, and Z.
Weight	NS12: 2.5 kg max.; NS10: 2.3 kg max.; NS8: 2.0 kg max.; NS5: 1.0 kg max.
Enclosure rating	Front operating panel: IP65F and NEMA4 compliant (See note 3.)
Battery life	5 years (at 25°C) Replace battery within 5 days after the battery runs low (indicator lights orange).
Applicable standards	cULus and EC directives

Note 1: The operating temperature is subject to the following restrictions according to the mounting angle.
Mounting angle of 0 to 30° to the horizontal: Operating temperature range of 0 to 45°C
When a Video Input Unit or a Controller Link Interface Unit is mounted, the ambient operating temperature is 0 to 35°C.
Mounting angle of 30 to 90° to the horizontal: See note 4.

Note 2: Operate the PT within the temperature and humidity ranges shown in the following diagram.

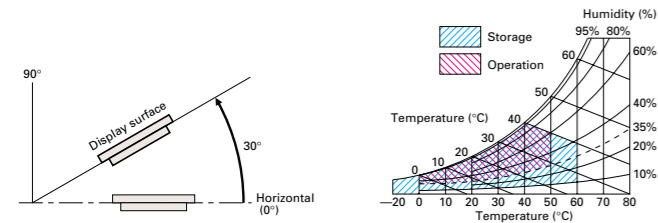

Note 3: May not be applicable in locations with long-term exposure to oil.

Note 4: -NS12/NS10/NS5

Mounting angle of 30° to 90° or less to the horizontal: Operating temperature range of 0 to 50°C

•NS8
Mounting angle of 30° to less than 90° to the horizontal: Operating temperature range of 0 to 45°C

Mounting angle of 90° to the horizontal: Operating temperature range of 0 to 50°C

NSH5-SQROOB-V2

Item	Specification
Rated power supply voltage	24 VDC
Allowable voltage range	20.4 to 26.4 VDC (24 VDC -15%/+10%)
Power consumption	10 W max.
Ambient operating temperature	0 to 40°C
Storage temperature	-20 to 60°C
Ambient operating humidity	35% to 85% with no condensation
Operating environment	No corrosive gases.
Noise immunity	Common mode: 1,000 Vp-p (between power supply terminals and panel) Normal mode: 300 Vp-p Pulse width: 100 ns to 1 μs, Rise time: 1-ns pulse
Vibration resistance (during operation)	Conforms to JIS C0911.
Shock resistance (during operation)	Conforms to JIS C0912.
Weight	1 kg max.
Enclosure rating	IP65 compliant
Ground	Ground to 100 Ω or less.
Applicable standards	UL508 and EC directives

Characteristics

Display Specifications

Item	NS12-V2	NS10-V2	NS8-V2	NS5-V2/NSH5-V2
Display device	High-definition TFT color LCD			TFT color LCD STN color LCD Monochrome LCD
Number of dots	800 dot horizontal x 600 dot vertical	640 dot horizontal x 480 dot vertical		320 dot horizontal x 240 dot vertical
Display color	256 colors			
Effective display area	Width 246.0 mm x height 184.5 mm (12.1 inches)	Width 215.2 mm x height 162.4 mm (10.4 inches)	Width 170.9 mm x height 128.2 mm (8.4 inches)	Width 117.2 mm x height 88.4 mm (5.7 inches)
Field of vision	Left/right ±60°, Top 45°, bottom 75° (See note 1.)	Left/right ±60°, Top 35°, bottom 65°	Left/right ±65°, Top 50°, bottom 60°	TFT: Left/right 70°, Top 70°, bottom 50° STN: Left/right 50°, Top 45°, bottom 50° Monochrome: Left/right 45°, Top 20°, bottom 40°
Service life	50,000 hours min. (See note 2.)			TFT, STN: 75,000 hours min. (See note 2.) Monochrome: 50,000 hours min. (See note 2.)
Brightness adjustment	There are 3 levels that can be set with the touch panel. (See note 3.)			
Backlight error detection	Error is detected automatically, and the RUN indicator flashes green as notification. (See note 4.)			

Note 1: The bottom angle is 55° for V1 models.

Note 2: This is the estimated time before brightness is reduced by half at room temperature and humidity. It is not a guaranteed value. The service life will be drastically shortened if PT is used at low temperatures. For example, using the PT at temperatures of 0°C will reduce the service life to approximately 10,000 hours (reference value).

Note 3: The brightness cannot be adjusted much.

Note 4: This function does not indicate that the service life has been reached. It detects when the backlight is not lit due to a disconnection or other errors. Backlight error detection indicates that all backlights (2) are OFF.

Note 5: Contact your nearest OMRON representative to replace the backlight.

Operating Specifications

Item	Specification	
Method	Resistive membrane	
Number of switches	NS12-V2	1,900 (50 horizontal x 38 vertical) 16 x 16 dots for each switch.
	NS10-V2	1,200 (40 horizontal x 30 vertical) 16 x 16 dots for each switch.
	NS8-V2	768 (32 horizontal x 24 vertical) 20 x 20 dots for each switch.
	NS5-V2/NSH5	300 (20 horizontal x 15 vertical) 16 x 16 dots for each switch.
Input	Pressure-sensitive	
Service life	1,000,000 touch operations.	

Data Capacity Specification

Series	Display device model	V 1	V 2
NS5	MQ (monochrome)	—	20 MB
	TQ (TFT)	—	20 MB
	SQ (STN)	6 MB	20 MB
NSH5	SQ (STN)	—	20 MB
NS8	TV (TFT)	20 MB	60 MB
NS10	TV (TFT)	20 MB	60 MB
NS12	TS (TFT)	20 MB	60 MB

External Interface Specifications

Item	Specifications
Memory card interface	One ATA-Compact Flash interface slot. Used to transfer and store screen data and to store history data.
Expansion interface	For Expansion Interface Units

Communications Specifications

Serial Communications

Item	Specification
Port A	Conforms to EIA RS-232C. D-Sub female 9-pin connector 5-V output (250 mA max.) through pin 6 (See note.)
Port B	Conforms to EIA RS-232C. D-Sub female 9-pin connector 5-V output (250 mA max.) through pin 6 (See note.)

Note: The 5-V outputs of serial ports A and B cannot be used at the same time.

Controller Link (Wired-type) Specifications

Item	Specification
Baud rate	2M/1M/500K
Transmission path	Shielded twisted-pair cable (special cable)

Ethernet Specifications

Item	Specification
Conformance standards	Conforms to IEEE 802.3/Ethernet (10Base-T/100Base-T).

Video Input Specifications

Item	NS-CA001	NS-CA002
Resolution	320 x 240, 640 x 480, or 800 x 600 dots	User-defined size
Input signal	NTSC composite video or PAL	NTSC composite video or PAL
Cameras	Number of cameras: 4 max.	2 cameras + RGB

USB Specifications

Item	Specifications
USB rating	USB1.1
Connector	Type A (Host), Type B (Slave)

Compatible OMRON PLCs

CPU Units (1:1 NT Link Connection)

Model number	Specifications	PLC model name
CQM1-CPU41-V1/CPU42-V1/CPU43-V1/CPU44-V1	With RS-232C connector (9-pin type)	C-series CQM1
CQM1H-CPU21/CPU51/CPU61		C-series CQM1H
CPM1-10/20CDR-□+ CPM1-CIF01	Connect to peripheral port.	C-series CPM1
CPM1A-10/20/30/40CD□-□+ CPM1-CIF01		C-series CPM1A
CPM2A-30/40/60CD□□-□+ CPM1-CIF01	Connect to RS-232C or peripheral port.	C-series CPM2A
CPM2C-10/20□□□□□□-□ (See note 1.)		C-series CPM2C
C200HS-CPU21/CPU23/CPU31/CPU33	With RS-232C connector (9-pin type)	C-series C200HS
C200HE-CPU32(-Z) (See note 2.) / CPU42(-Z)		C-series C200HE (-Z)
C200HG-CPU33(-Z) (See note 2.) / CPU43(-Z) / CPU53(-Z) (See note 2.) / CPU63(-Z)		C-series C200HG (-Z)
C200HX-CPU34(-Z) (See note 2.) / CPU44(-Z) / CPU54(-Z) (See note 2.) / CPU64(-Z) / CPU65-Z / CPU85-Z		C-series C200HX (-Z)
CV500/1000/2000-CPU01-V1 CVM1-CPU01-V2/CPU11-V2/CPU21-V2	With RS-232C connector (switching/9-pin type)	CVM1/CV-series CVM1 or CV500/ CV1000/CV2000

Note 1: Use an Adapter Cable (CPM2C-CN111 or CS1W-CN114/118), CPM1-CIF01 RS-232C Adapter, or CPM1-CIF11 RS-422A Adapter to connect.

Note 2: A C200HW-COM02(-V1), C200HW-COM04(-V1), C200HW-COM05(-V1), or C200HW-COM06(-V1) Communications Board is required.

CPU Units (1:N NT Link Connection)

Model number	Specifications	PLC model name
CS1G-CPU42H/CPU43H/CPU44H/CPU45H	With RS-232C connector (9-pin type)	CS-series CS1G
CS1H-CPU63H/CPU64H/CPU65H/CPU66H/CPU67H		CS-series CS1H
CS1D-CPU65H/CPU67H		CS-series CS1D
CJ1G-CPU42H/CPU43H/CPU44H/CPU45H (See note 1.)		CJ-series CJ1G
CJ1G-CPU42P/CPU43P/CPU44P/CPU45P		CJ-series CJ1G
CJ1H-CPU65H/CPU66H/CPU67H (See note 1.)		CJ-series CJ1H
CJ1M-CPU11/CPU12/CPU13/CPU21/CPU22/CPU23 (See note 1.)		CJ-series CJ1M
CQM1H-CPU61/51 with a CQM1H-SCB41 Serial Communications Board		C-series CQM1H
C200HE-CPU32(-Z) (See note 2.) / CPU42(-Z)		C-series C200HE(-Z)
C200HG-CPU33(-Z) (See note 2.) / CPU43(-Z) / CPU53(-Z) (See note 2.) / CPU63(-Z)		C-series C200HG(-Z)
C200HX-CPU34(-Z) (See note 2.) / CPU44(-Z) / CPU54(-Z) (See note 2.) / CPU64(-Z) / CPU65-Z / CPU85-Z		C-series C200HX(-Z)

Note 1: The CJ1W-SCU21/SCU41 Serial Communications Unit can also be connected.

Note 2: A C200HW-COM02/COM04/COM05/COM06(-V1) Communications Board is required.

Display Element Specifications

Item	Specification		
Display text	Raster font	Displayable characters Base size	
	Font name	Rough	Alphanumeric characters or Japanese katakana 8 x 8 1 x 1, 1 x 2, 2 x 1, 2 x 2, 3 x 3, 4 x 4, 8 x 8
		Standard	Alphanumeric characters or Japanese, Chinese (Simplified, Traditional) or Korean 8 x 16 1 x 1, 1 x 2, 2 x 1, 2 x 2, 3 x 3, 4 x 4, 8 x 8
		Fine	Alphanumeric characters or Japanese katakana Japanese kanji 16 x 32 1 x 1, 1 x 2, 2 x 1, 2 x 2, 3 x 3, 4 x 4, 8 x 8
Vector font (text objects only)	Can be specified in CX-Designer. Font, style, and size can be specified.		
Text attributes	Color	256 colors	
	Font style (only when vector font is specified)	Bold or italic	
	Vertical alignment	Top, center, or bottom	
Horizontal alignment	Left-justified, centered, or right-justified		
	Flicker	Objects that can flicker	
Functional objects	Up to 10 types can be registered. The flicker speed and flicker range can be set.		
	Fixed objects	Select from 3 types. The flicker speed and flicker range are fixed.	
Numeral units and scale settings	1,000 max.		
Alarm/event settings	5,000 max.		
Display colors	256 colors max. (32,768 colors for BMP)		

CX-One Operating Environment

Compatible OS	Windows 98 SE, Me, NT 4.0 (Service Pack 6a), 2000 (Service Pack 3 or higher), or XP (See note 1.)
Recommended CPU	Pentium II 333 MHz or faster processor (Pentium III 1 GHz or faster recommended.)
Recommended memory	256 Mbytes min. (See note 2.)
Hard disk free space	Approx. 1.8 GB or more available space is required to install the complete CX-One package.
CD-ROM drive	Required for installation
Display	SVGA (800 x 600) or better high-resolution display with 256 colors min.

Note 1: CX-One OS precaution

The CX-One will not run on Microsoft Windows 95 or any other OS not listed above.

If such an OS is being used on the client computer, the OS must be upgraded before installing the CX-One. System requirements and hard disk space may vary with the system environment.

Note 2: The amount of memory required varies the Support Software applications used in CX-One.

Refer to use documentation for Individual Support Software for details.

Connections through CPU Unit/Host Link

Model number	Specifications	PLC model name
CPM1-10CDR/20CDR-□/CPM1A-10CD/20CD/30CD/40CD-□	RS-232C or RS-422A adapter connected to peripheral port	C Series: CPM1
CPM2A-30CD/40CD/60CD-□-□	RS-232C connector (9-pin)	C Series: CPM2A
CPM2C-10/20-□□□□□□-□	Communications connectors include both a peripheral port and RS-232C port (branching possible through CPM2C-CN111 Conversion Cable). Used as separate peripheral and RS-232C ports through CS1W-CN114/118 Conversion Cable.	C Series: CPM2C
CQM1-CPU21/CPU41-V1/CPU42-V1/CPU43-V1/CPU44-V1	RS-232C connector (9-pin)	C Series: CQM1
CQM1H-CPU11/CPU21/CPU51/CPU61	RS-232C connector (9-pin) (Only peripheral port for CQM1H-CPU11)	C Series: CQM1H
C200HS-CPU21/CPU23/CPU31/CPU33	RS-232C connector (9-pin, selectable)	C Series: C200HS
C200HE-CPU32(-Z)(See note.)/CPU42(-Z)		C Series: C200HE (-Z)
C200HG-CPU33(-Z)(See note.)/CPU43(-Z)/CPU53(-Z)(See note.)/CPU63(-Z)		C Series: C200HG (-Z)
C200HX-CPU34(-Z)(See note.)/CPU44(-Z)/CPU54(-Z)(See note.)/CPU64(-Z)/CPU65(-Z)/CPU85-Z		C Series: C200HX (-Z)
CS1G-CPU42(-V1)/CPU43(-V1)/CPU44(-V1)/CPU45(-V1)	RS-232C connector (9-pin)	CS Series: CS1G
CS1H-CPU63(-V1)/CPU64(-V1)/CPU65(-V1)/CPU66(-V1)/CPU67(-V1)		CS Series: CS1H
CV500-CPU01-V1/CV1000-CPU01-V1/CV2000-CPU01-V1/ CVM1-CPU01-V2/CPU11-V2/CPU21-V2	RS-232C connector (9-pin, selectable)	CVM1/CV Series: CV500/1000/2000 or CVM1

Note: The C200HW-COM02, C200HW-COM04, C200HW-COM05, or C200HW-COM06(-V1) Communications Board is required.

Standard Models

Model name	Specifications	Ethernet		Case color	Model number	Standards
		Yes	No			
NS12	12-inch TFT 800 x 600 dots	No	No	Ivory	NS12-TS00-V2	CU, CE
				Black	NS12-TS00B-V2	CU, CE
		Yes	No	Ivory	NS12-TS01-V2	CU, CE
				Black	NS12-TS01B-V2	CU, CE
NS10	10-inch TFT 640 x 480 dots	No	No	Ivory	NS10-TV00-V2	CU, CE
				Black	NS10-TV00B-V2	CU, CE
		Yes	No	Ivory	NS10-TV01-V2	CU, CE
				Black	NS10-TV01B-V2	CU, CE
NS8	8-inch TFT 640 x 480 dots	No	No	Ivory	NS8-TV00-V2	CU, CE
				Black	NS8-TV00B-V2	CU, CE
		Yes	No	Ivory	NS8-TV01-V2	CU, CE
				Black	NS8-TV01B-V2	CU, CE
NS5	5-inch STN 320 x 240 dots	No	No	Ivory	NS5-SQ00-V2	CU, CE
				Black	NS5-SQ00B-V2	CU, CE
		Yes	No	Ivory	NS5-SQ01-V2	CU, CE
				Black	NS5-SQ01B-V2	CU, CE
	5-inch TFT 320 x 240 dots	No	No	Ivory	NS5-TQ00-V2	CU, CE
				Black	NS5-TQ00B-V2	CU, CE
		Yes	No	Ivory	NS5-TQ01-V2	CU, CE
				Black	NS5-TQ01B-V2	CU, CE
	5-inch monochrome 320 x 240 dots	No	No	Ivory	NS5-MQ00-V2	CU, CE
				Black	NS5-MQ00B-V2	CU, CE
		Yes	No	Ivory	NS5-MQ01-V2	CU, CE
				Black	NS5-MQ01B-V2	CU, CE
NS5 Hand-held	5-inch STN 320 x 240 dots	No	No	Black	NSH5-SQR001B-V2	CE, CU (approval pending)

Model name	Specifications	Model number	
CX-One FA Integrated Tool Package Ver. 1.1	The CX-One is an integrated tool package that provides programming and monitoring software for OMRON PLCs and components. The CX-One runs on any of the following operating systems: Windows 98 SE, Me, NT 4.0 (Service Pack 6a), 2000 (Service Pack 3 or higher), or XP. CX-Designer version 1.□ is included in the CX-One. Refer to the CX-One catalog (R134) for details. (See note 2.)	1 license	CXONE-AL01C-E
		3 licenses	CXONE-AL03C-E
		10 licenses	CXONE-AL10C-E
		30 licenses	CXONE-AL30C-E
		50 licenses	CXONE-AL50C-E
The CX-Designer can also be ordered individually using the following model number.			
CX-Designer Ver. 1.□	OS: Window 98 SE, Me, NT 4.0 (Service Pack 6a), 2000 (Service Pack 3 or higher), or XP. The Ladder Monitor Software is included.	1 license	NS-CXDC1-V1
Cable (See note 1.)	Screen transfer cable for DOS/V	XW2Z-S002	
	USB Host Cable, cable length: 5 m	NS-US52 (5 m)	
	USB Host Cable, cable length: 2 m	NS-US22 (2 m)	
NSH5 Cables	USB-RS-232C Conversion Cable, cable length: 0.5 m	CS1W-CIF31	
	RS-422A cable (loose wires) Cable length: 10 m	NSH5-422CW-10M	
	RS-232C cable (loose wires) Cable length: 3 m	NSH5-232CW-3M	
PT-to-PLC Connecting Cable	RS-232C cable (loose wires) Cable length: 10 m	NSH5-232CW-10M	
	PT connection: 9 pins PLC connection: 9 pins	Length: 2 m XW2Z-200T Length: 5 m XW2Z-500T	
NSH5 Wall-mounting Bracket		NSH5-ATT02	

Note 1: Use an OMRON USB Host Cable to connect an NS-series PT to a printer.
2: Site licenses are also available for users that need to use the CX-One on many computers. Ask your OMRON representative for details.

Options

Model name	Specifications	Model number	
Video Input Unit	Inputs: 4 channels Signal type: NTSC/PAL	NS-CA001	
	Input channels: 2 video channels and 1 RGB channel (See note.) Signal mode: NTSC/PAL	NS-CA002	
Special Cable for the Console		F150-VKP (2m)	
		F150-VKP (5m)	
Controller Link Interface Unit	For Controller Link Communications	NS-CLK21	
RS-422A Adapter	Transmission distance: 500 m total length Note: Use this model when connecting PT models without a V□ suffix. Note: PT models with a suffix of V□ can also be connected.	NS-AL002	
	Transmission distance: 50 m total length Note: Only PT models with a suffix of V□ are connectable. Use the NS-002 to connect models without a V□ suffix.	CJ1W-CIF11	
Sheet/Cover	Anti-reflection Sheets (5 surface sheets)	NS12/10	NS12-KBA04
		NS8	NS7-KBA04
		NS5	NT30-KBA04
	Protective Covers (5 pack) (anti-reflection coating)	NS12/10	NS12-KBA05
		NS8	NS7-KBA05
		NS5	NT31C-KBA05
Protective Covers (5 covers included) (Transparent)	NS12/10	NS12-KBA05N	
	NS8	NS7-KBA05N	
	NS5	NT31C-KBA05N	
Attachment	(NT625C/631/631C Series to NS12/10 Series)	NS12-ATT01	
	(NT625C/631/631C Series to NS12/NS10 Series) (Black)	NS12-ATT01B	
	(NT610C Series to NS12/10 Series)	NS12-ATT02	
	(NT620S/620C/600S Series to NS8 Series)	NS8-ATT01	
	(NT600M/600G/610G/612G Series to NS8 Series)	NS8-ATT02	
Memory Card	30 MB	HMC-EF372	
	64 MB	HMC-EF672	
Memory Card Adapter		HMC-AP001	
Battery		CJ1W-BAT01	
Bar Code Reader (Refer to the Catalog for details.)		V520-RH21-6	

Note: One screen cannot display two video inputs simultaneously.

Related Products

WS02-NSFC1-EV2 Face Plate Auto-BUILDER for NS

Significantly reduces the engineering time required by combining LCB/LCU and the NS Series.

- Automatic generation of control screens and tuning screens. Automatic generation of NS screen data by the software from tag information created with CX-Process Tool.
- NS communications address allocation, ladder programs, etc., are completely unnecessary.
- Data that has been generated can be freely edited and processed by CX-Designer (NS screen creation software).

- NS Faceplate Auto-BUILDER upgraded to version 2.0.
- Maximum number of automatically generated loops increased from 32 to 100.
- Automatic generation from the CX-Process projects that use multiple nodes.
- Automatic generation of detailed setting screens for Line Segment programs.

Specifications

Product name	Specifications	Model number
Face Plate Auto-BUILDER for NS	CSV tag files for LCB/LCU used in Face Plate Auto-BUILDER for NS	WS02-NSFC1-EV2

Superior environmental resistance meets IP65F standards.

Flush surface construction is used for superior environmental resistance and the enclosure rating for the front of the PT is IP65F compliant.

- IP → International Protection
- 6 → Dust and dirt will not enter interior. (Enclosure protects against foreign objects.)
 - 5 → There are no adverse effects from a water stream from any direction. (Enclosure protects against water intrusion.)
 - F → There are no harmful effects from oil droplets or spray from any direction. (Enclosure protects against oil intrusion.)

Note: May not be applicable in environments with long-term exposure to water or oil.

Meets International Standards and Exports are Not Restricted

The PTs conform to UL standards (cULus) and EC Directives.

In addition, there are no export restrictions on the PTs. cULus certification is scheduled for the near future for the NSH5 5-inch Hand-held PT.

