

DriveRight 600E **OBDII Installation Guide**

Product # 81260BD



DAVIS
Davis Instruments

FCC Part 15 Class B Registration Warning

This equipment has been tested and found to comply with the limits for a Class B digital device, pursuant to Part 15 of the FCC Rules. These limits are designed to provide reasonable protection against harmful interference in a residential installation. This equipment generates, uses, and can radiate radio frequency energy and, if not installed and used in accordance with the instructions, may cause harmful interference to radio communications.

However, there is no guarantee that interference will not occur in a particular installation. If this equipment does cause harmful interference to radio or television reception, which can be determined by turning the equipment on and off, the user is encouraged to try to correct the interference by one or more of the following measures:

- Reorient or relocate the receiving antenna.
- Increase the separation between the equipment and receiver.
- Connect the equipment into an outlet on a circuit different from that to which the receiver is connected.
- Consult the dealer or an experienced radio/TV technician for help.

Changes or modification not expressly approved in writing by Davis Instruments may void the warranty and void the user's authority to operate this equipment.

© Davis Instruments Corp. 2007. All rights reserved.

DriveRight OBDII Installation Guide

Rev. D (February 15, 2007)

Product # 8126OBD

Document Part Number: 07395.198

This product complies with the essential protection requirements of the EC EMC Directive 89/336/EC.

EMC Directive 95/54/EC (E-mark)

 Tested to comply
with FCC standards
FOR HOME OR OFFICE USE



DriveRight is a registered trademark of Davis Instruments Corp., Hayward, CA.

Velcro is a trademark of Velcro Industries, Manchester, NH.

Information in this document subject to change without notice.

DAVIS 
Davis Instruments

3465 Diablo Avenue, Hayward, CA 94545-2778 U.S.A.

510-732-9229 • Fax: 510-732-9188

E-mail: info@davisnet.com • www.davisnet.com

Introduction

This manual provides instructions and information necessary to install the OBD version of the DriveRight 600E device. The DriveRight OBD plugs into your vehicle's OBDII (On-Board Diagnostics II) port for a quick and easy installation.

Note: DriveRight OBD only functions in vehicles equipped with a compatible OBDII port. See "Appendix 1: OBDII Compatibility" on page 10 for a list of supported OBDII protocols and vehicles.

Components

Your DriveRight OBD installation kit should come with all the components shown below. Please make sure you have all listed items before proceeding.

Note: Hardware includes spare pieces not required for all installation.

Console and Mounting Hardware

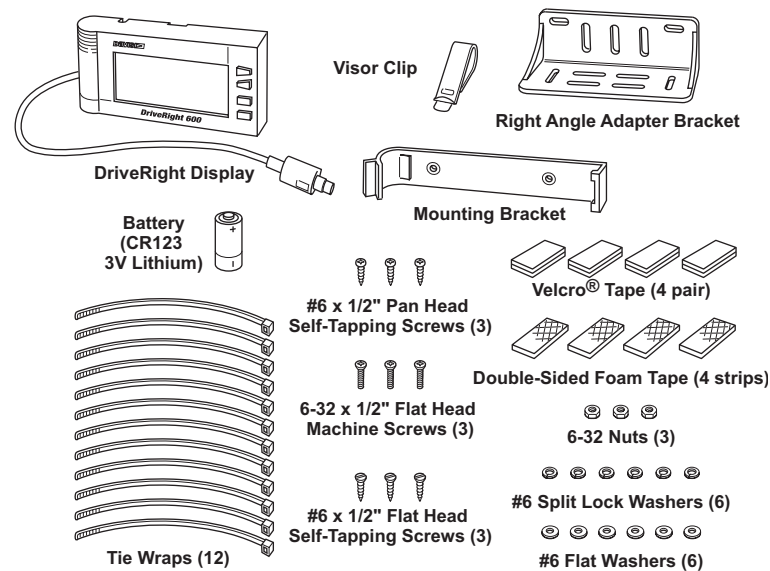

Cables

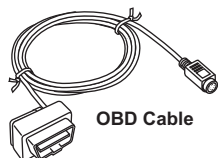

OBD Cable

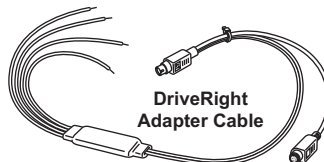

DriveRight
Adapter Cable

Wiring Components



Red +12V Wire
with Fuseholder (22 AWG)



Blue Wire (2) with Fuseholder (22 AWG)



Black Ground Wire
(22AWG)

Spade Terminal Sets:



#8-10 Studs
(3.5 - 5 mm)



1/4" Studs
(6 mm)



Insulated Male Disconnects
(18-22AWG)



Fuses (4)
(3AG 1-1/4 x 1/4",
.25A, Slo-Blo)

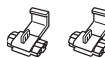

In-Line Splice (3)



Butt Splices (5)
(26-22AWG or 24-20AWG)

T-Tap Disconnects:



Blue
(14-16AWG)



Red (3)
(18-22AWG)

Additional DriveRight Documentation

Refer to the following documents for information on configuring and using your DriveRight:

- The DriveRight 600E *User's Guide* included with your unit.
- The Online Help System in the DriveRight software.
- The *DriveRight FMS User's Manual* located in an Adobe Acrobat PDF file in your DriveRight program directory.

Tools and Materials Needed

DriveRight installation may require some or all of the following tools and materials. Please review the installation instructions and make sure you have all necessary items before proceeding with the installation.

All Installations

- **Electric Drill with 7/64" (2.5 mm) Drill Bit** - Used to drill the tap holes for #6 self-tapping screws.
- **Medium Phillips Screwdriver**
- **Pliers**

Installations using Adapter Cable Digital Inputs

If you are using the adapter cable digital inputs in your installation, the following additional tools and other items may also be required:

- **Crimping Tool**
- **Multimeter**
- **Fuse Tap** - Required to obtain +12 V from the fuse panel.

Planning the Installation

Installation of the DriveRight OBD is simple. Unless you are using the two digital inputs on the adapter cable, you only need to plug the OBD cable into your vehicle's OBDII port and then install the DriveRight console.

The digital inputs on the DriveRight 600E adapter cable may be used to monitor any 12 VDC electrical device or accessory in the vehicle, but they are typically used for monitoring accessories like the brake lights, headlights, or seat belts.

To install DriveRight OBD:

1. Plug the OBD cable into your vehicle's OBDII port.
2. Connect the digital inputs (if used).
3. Install the DriveRight console in the vehicle.
4. Test the DriveRight installation.

Wiring Diagram

The diagram below is an example of DriveRight OBD wiring.

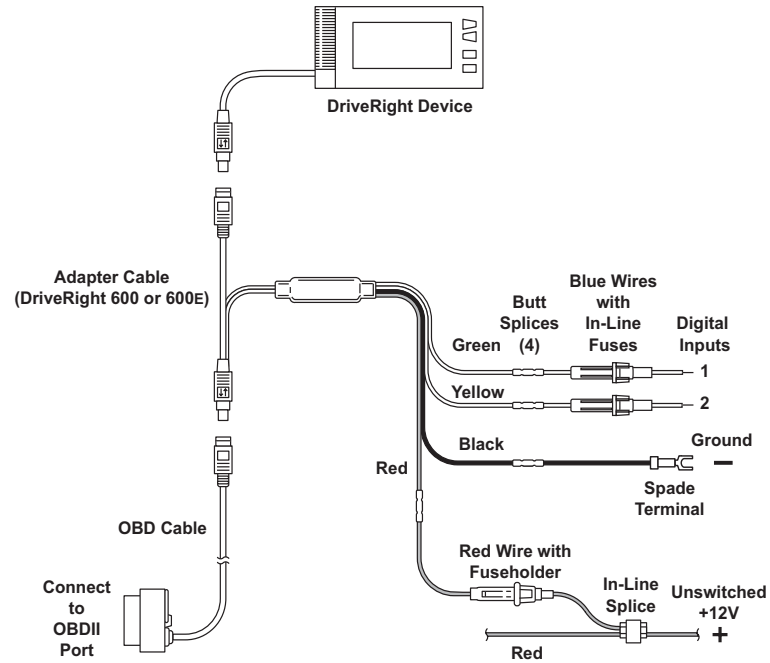

Procedure 1: Connect OBD Cable to OBDII Port.

1. Locate the OBDII port in the vehicle.

The OBDII port will be located within 3 feet of the steering wheel, usually within the general area indicated by the dotted line in the illustration below. The port should be easily accessible by a person sitting in the driver's seat without the use of tools.

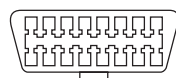

OBDII Port

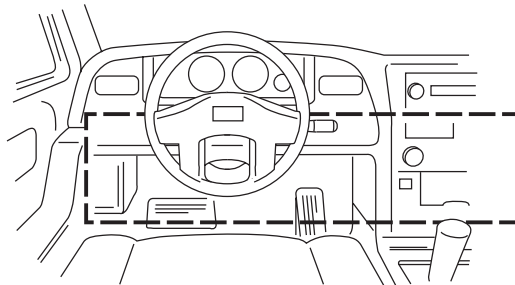

Look in the follow areas if you have trouble finding the OBDII port:

- Under the dash
- In front of the passenger seat
- Behind the ash tray
- Behind a small access panel in the dash
- In or around the center console

2. Plug the OBD cable into the port.

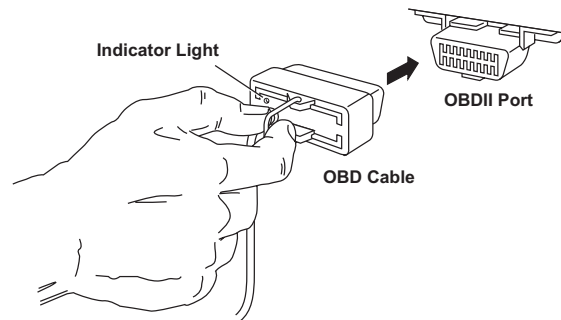

Note: The indicator light blinks three times when first plugged in, then blinks twice per second until the connector establishes communications with the OBDII computer. When communication has been established, the indicator blinks once then remains off.

Note: The ignition must be ON to establish communication.

Note: When the vehicle is driven, the indicator blinks once for each speed reading.

Procedure 2: Connect the Digital Inputs (if used)

Two digital inputs located on the adapter cable are available to monitor the on/off state of lights, including brake lights, or of other 12 VDC electrical accessories. An example of a digital input configuration may be Digital Input 1 connected to the brake lights while Digital Input 2 connected to the headlights. In the DriveRight Fleet Management Software (FMS), Digital Input 1 is recorded in the GPS table and in the accident logs. Digital Input 2 is only recorded in the GPS table.

- You can record the digital input status during a trip by enabling GPS in DriveRight FMS, even if you aren't using the optional module.
- The adapter cable is required for DriveRight 600E even if you do not use the digital inputs.

Note: Connecting the digital inputs can be hazardous to both the installer and your vehicle's electrical system if not done by an experienced installer. This manual assumes you are aware of the inherent dangers of working in and around a vehicle and have a working understanding of electricity.

1. If you are installing a DriveRight 600E OBD but not using the digital inputs, go to Step 10 of this procedure.
2. Butt splice the red fuse holder to the red wire from the adapter cable.
3. Tap the red fuse holder to an unswitched +12 V source using the in-line splice provided with your DriveRight or using a fuse tap connector (not included) appropriate for your vehicle.

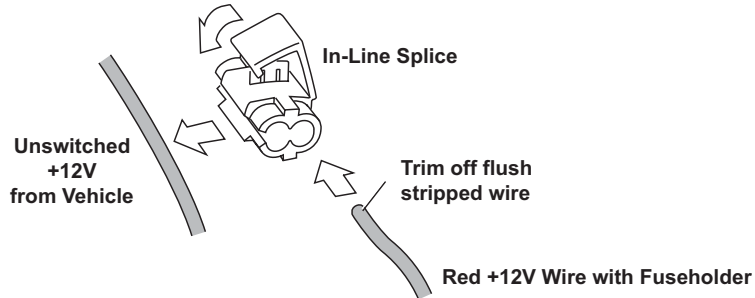

You can obtain +12V from several places. Usually, you can easily obtain +12V from the fuse box using a fuse tap connector (not supplied) or using the supplied in-line splice connectors to tap into a known circuit that does not involve safety related equipment such as headlights, tail lights, air bag, etc. Possible candidate wires include those from the cigarette lighter, dome light, glove compartment light, clock, tail gate light, or other convenience functions.

If you are getting +12V from your fuse box, use a fuse tap connector appropriate for your vehicle.

4. Butt splice the black ground wire from the adapter cable to black ground wire included with your DriveRight.
5. Crimp a spade terminal, included with the unit, to the other end of the black wire. Refer to the illustration.
6. Connect the spade terminal to a vehicle chassis ground.

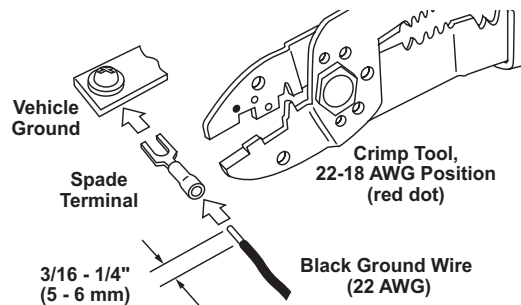

Note: Use a multimeter to test the vehicle chassis ground before connecting to the ground wire.

-
7. Use the in-line butt splices to connect the blue wires with fuses to the Green (Digital Input 1) and Yellow (Digital Input 2) wires from the adapter cable.
 8. Connect Digital Input 1 to the desired circuit.
 9. Connect Digital Input 2 to the desired circuit.
 10. Connect the digital input cable to the OBD cable.

It is easiest to make the connection by first holding the OBD cable connector by the housing. Then hold the adapter connector on the cable itself next to the sliding connector housing and push the two connectors together. The two cables will lock together when properly connected.

Note: To disconnect the cables, hold the both cables by the housing and pull apart. The sliding housing on the adapter cable connector will release the lock and allow the cables to be separated.

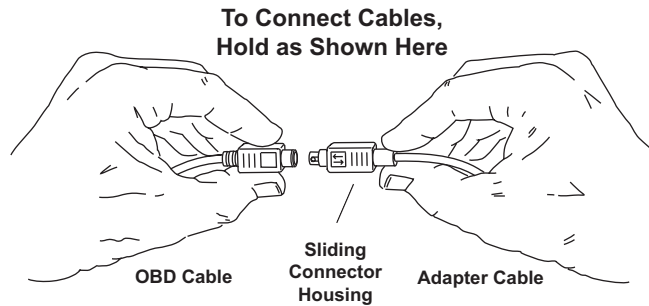

Procedure 3: Install the DriveRight Console

1. The DriveRight console can be mounted in a number of places, including the top of the dash, on the face of the dash, or on a sun visor. Some of the different mounting choices are illustrated below and on the following page:

Face of Dashboard Mounting Options

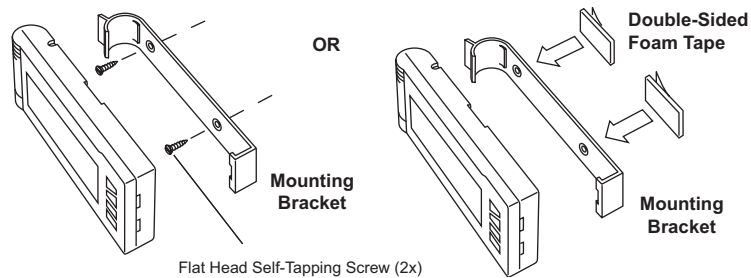

Top of Dashboard Mounting Using Brackets or Velcro™

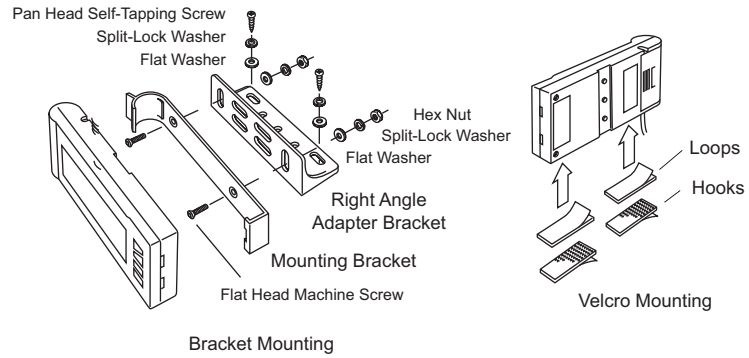

Sun Visor Mounting

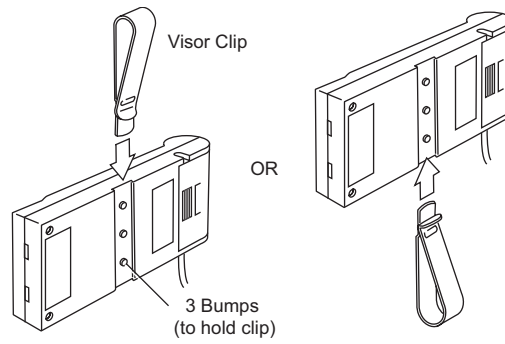

2. Insert the battery into the DriveRight console.

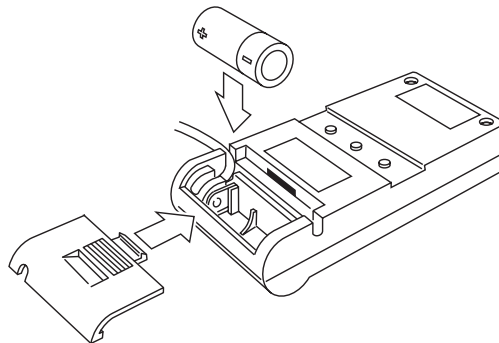

3. Connect the DriveRight console cable to the adapter cable.

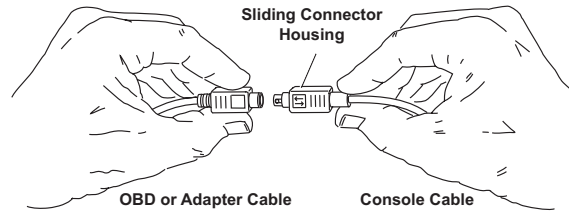

Hold cables as shown to connect. The connector housing on the console cable slides back when you make the connection, allowing the cables to lock together.

Note: To disconnect the cables, hold the both cables by the connector housing and pull apart. The sliding housing on the console cable connector will release the lock and allow the cables to be separated.

Once plugged in, the console should “wake-up” into the Current Readings screen. If the display remains blank, make sure the battery is properly installed in the unit. If it is, try pressing MODE. If the screen remains blank after pressing MODE, press both MODE and PLUS simultaneously. If it remains blank after that, check the OBDII port connection.

Procedure 4: Test the Installation

1. Take a test drive and verify that the console displays vehicle speed.
2. If the speed shown in the DriveRight console appears to be off, check the console’s calibration. You can calibrate DriveRight in the vehicle using the instructions in your DriveRight User’s Guide, but you will have much better accuracy with the DriveRight OBD if you calibrate it in the DriveRight software using the following settings:
 - PPM (pulses per mile) = 75,000
 - PPR (pulses per reading) = calculated by software
 - Calibration Number = calculated by software

Note: If you are using DriveRight FMS 3.1 or later, just select the “OBD” installation method in the **Device Settings** dialog box when you configure the DriveRight console.

Appendix 1: OBDII Compatibility

Use this list to verify the compatibility of your vehicle's OBDII port with DriveRight OBD.

Supported OBDII Protocols

- J1850-41.6 (PWM)
- J1850-10.4 (VPW)
- ISO9141
- KWP2000 (ISO 14230)
- CAN (Controller Area Network - ISO11898)

Supported US Vehicles

- Most domestic and import vehicles, 1996 or later

Supported Vehicles Outside of the US

- In Europe, some 1996 and later vehicles and most 2000 and later vehicles compliant with the supported protocols listed above
- Outside of the US and Europe, most 1996 and later vehicles compliant with supported OBDII protocols

Technical Support

If you are experiencing problems with your DriveRight, first check the cable connections and verify the calibration settings. If you are unable to solve the problem, please call Davis Technical Support. We'll be glad to help. Most questions can be answered on the phone. You can also email us for support, or visit our website. Sorry, we are unable to accept collect calls.

Note: Please do not return items for repair without prior authorization.

(510) 732-7814 – Monday through Friday, 7:00 a.m. to 5:30 p.m. Pacific Time.

(510) 670-0589 – Fax to Technical Support.

support@davisnet.com – E-mail to Technical Support.

info@davisnet.com – E-mail to Davis Instruments.

www.davisnet.com – Product documentation is available on the DriveRight Support section of our website. Watch for FAQs and other updates.

Installation Notes:

Installation Notes:

Installation Notes: