



# SUMMIT®

## PLATINUM D4 / D6

### BUILT-IN NG GAS GRILL INSTALLATION GUIDE

# 42370

**THIS GAS APPLIANCE IS DESIGNED FOR OUTDOOR USE ONLY.**

#### LOCATING YOUR GRILL

When determining a suitable location for your Summit® gas grill installation, give attention to concerns such as exposure to wind, proximity to traffic paths, and keeping any gas supply lines as short as possible. Never locate the Summit® gas grill in a garage, breezeway, shed, under an unprotected overhang, or other enclosed area. Locate the grill and structure so there is enough room to safely evacuate the area in case of a fire.

#### CLEARANCE FROM SURFACES OR STRUCTURES

**⚠ WARNING: Clearance from any surface or structure is 24 inches (609.6 mm) from the back and sides of the grill. Refer to “Typical Gas Supply Installation” before starting installation.**

**⚠ WARNING: The structure, “island”, countertops, and adjacent work areas for the built-in grill installation must be built from noncombustible materials only.**

*NOTE: If you have questions on what materials are considered noncombustible, contact your local building materials supplier or fire department.*

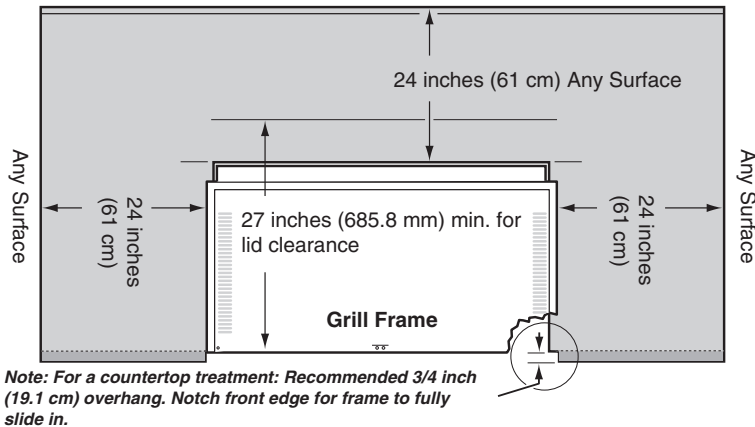

#### BUILT-IN STRUCTURE CUTOUT DIMENSIONS ALL DIMENSIONS ARE TO FINISHED SURFACES.

**⚠ WARNING: All countertop finished surfaces must be constructed of a noncombustible material.**

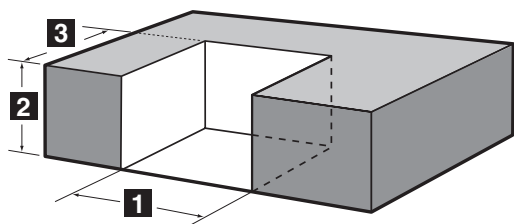

Built-In Cutout Dimensions			
	D4	D6	Tolerances
<b>1</b>	30 1/4"	38 1/4"	+ 1/4" - 1/4"
<b>2</b>	34 1/4"	34 1/4"	+ 1/4" - 1/4"
<b>3</b>	21"	21"	+ 1/4" - 1/4"

# BUILT-IN CUTOUT DIMENSIONS

## GENERAL CONSTRUCTION DETAILS

Summit® Built-In unit and all other accessory units should be on site before construction begins. All dimensions have a tolerance of plus or minus (+/-) 1/4 inch. The grill frame rests directly on the Island Structure top finished surface. Make sure this surface is level. Do not support the grill from the bottom. If the supporting structure is going to have an electrical outlet for a rotisserie, it should be on the left side of the structure.

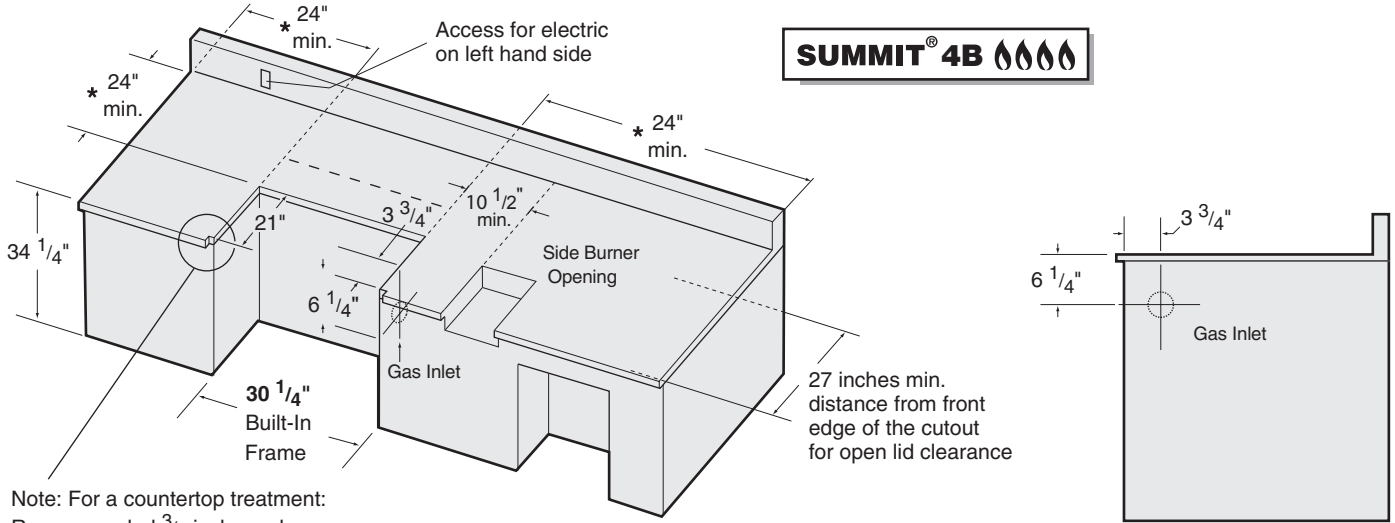

Note: For a countertop treatment:  
Recommended 3/4 inch overhang.  
Notch front edge for frame to fully slide in.

**\*Clearance from any surface or structure is at least 24 inches from the back and sides of the grill.**

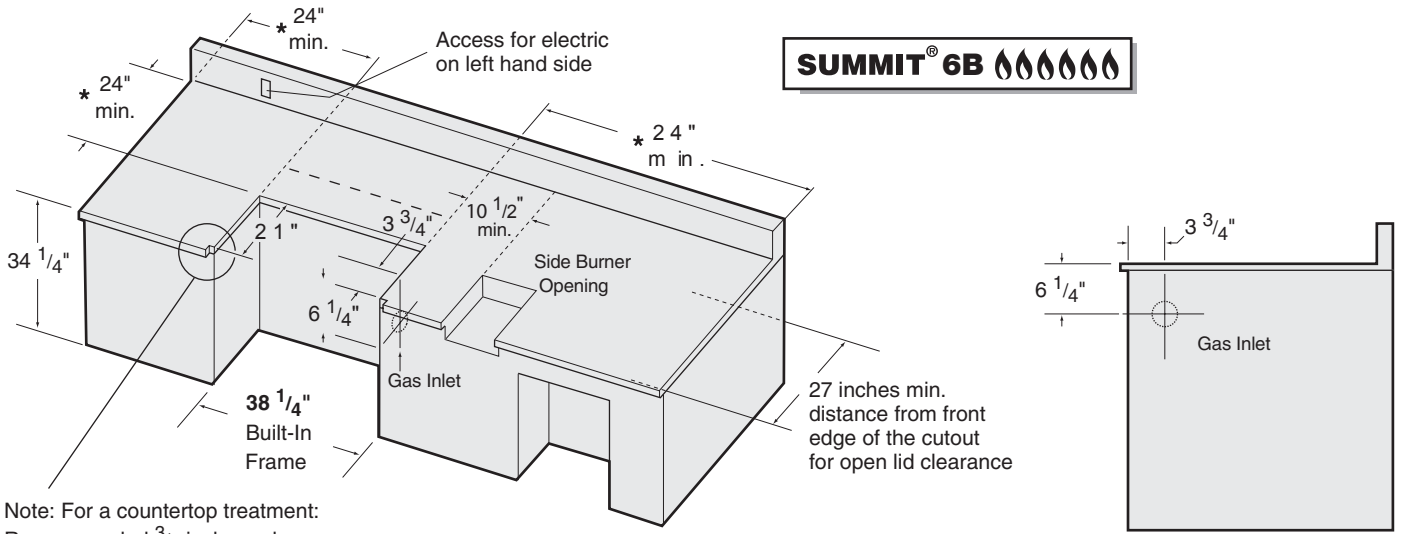

Note: For a countertop treatment:  
Recommended 3/4 inch overhang.  
Notch front edge for frame to fully slide in.

**\*Clearance from any surface or structure is at least 24 inches from the back and sides of the grill.**

## SUMMIT® 4B 🔥🔥🔥

Lid - 1

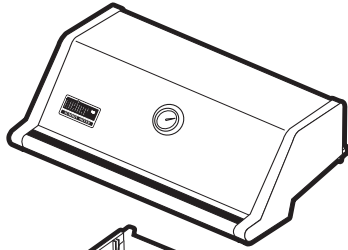

Cookbox - 1

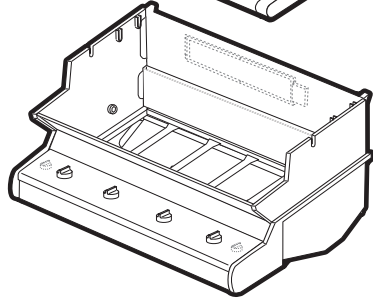

OR

## SUMMIT® 6B 🔥🔥🔥🔥

Lid - 1

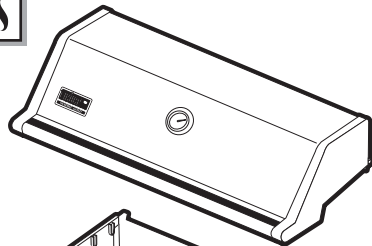

Cookbox - 1

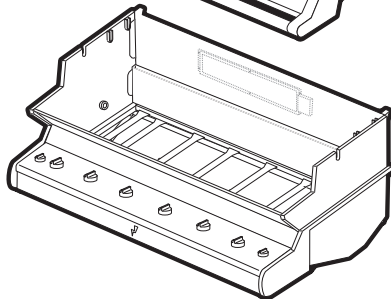

Front Frame Rail - 1



Rear Frame Rail - 1

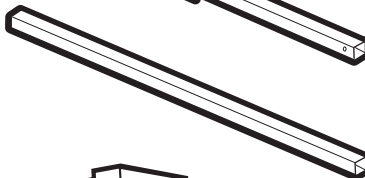

Rear Panel Assembly - 1

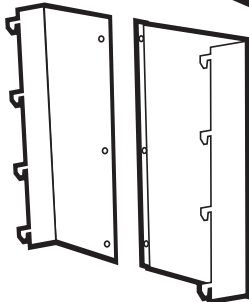

Bottom Shelf - 1



Left Door - 1

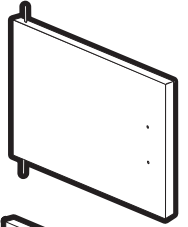

Right Door - 1

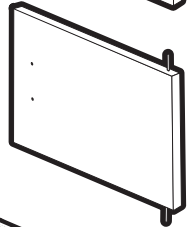

Warming Rack - 1

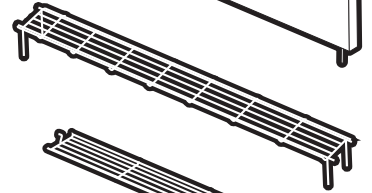

Warm-Up™ Rack - 1

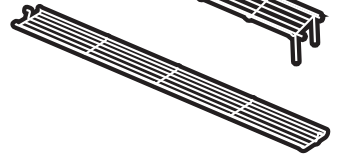

Right Enclosure Panel - 1

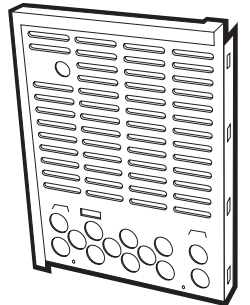

Left Enclosure Panel - 1

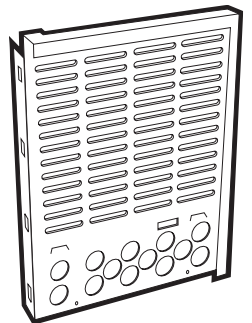

Front Vent Panel - 1

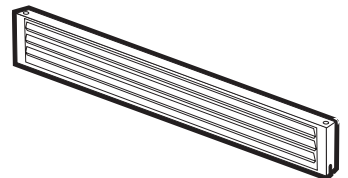

Rear Vent - 1

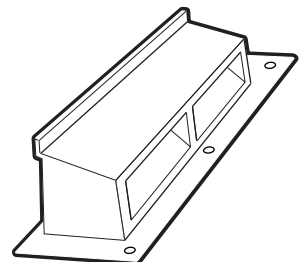

# PARTS LIST (CONTINUED)

Flavorizer® Bars - 2 Sets

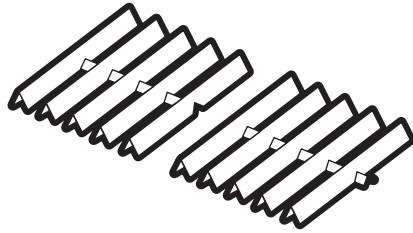

Stainless Steel Cooking Grates

**SUMMIT® 4B** 

- 2

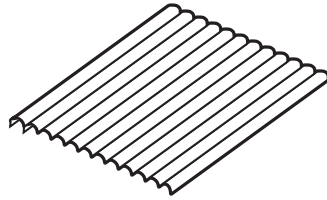

**SUMMIT® 6B** 

- 3

Bottom Tray - 1

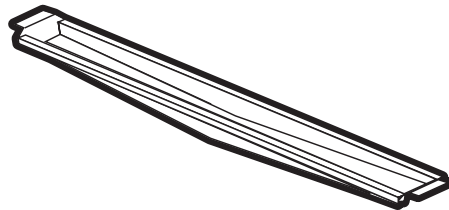

Catch-Pan Holder - 1

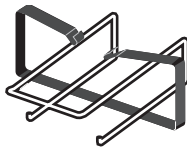

Catch-Pan - 1



Disposable Drip Pans - 2

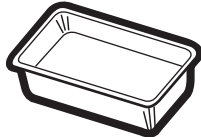

Hinge Pin- 2



Hair Pin Cotter- 2



Corrugated gas line - 1

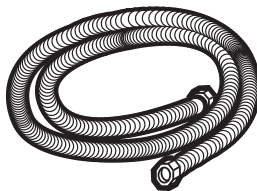

Right Front Vent Clip - 1



Left Front Vent Clip - 1



7/16 inch Wrench - 1



Wrench - 1



x10 Sheet Metal Screws - 3



Plastic Anchors - 3



1/2 inch Bolts  
(1/4 x 20 x 1/2 inch Bolt) - 8

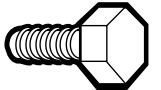

#10-32 x 1/4 inch Steel Screws - 5



Nylon Washer - 8



1/2" Flare Gasket - 2



3/8" Flare Gasket - 2



Handle - 2



Handle Hardware - 4



Rotisserie - 1



Rotisserie Motor - 1

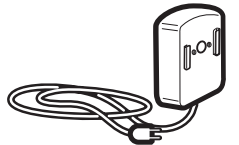

Rotisserie Bracket - 1



Keps Nuts (1/4 x 20 Blk Zinc) - 2



Rotisserie Bracket Hardware- 2



Smoker - 1

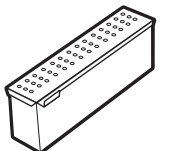

# EXPLODED VIEW - PLATINUM D4

5340501 - Summit® Platinum D4 NG Built-In 091905

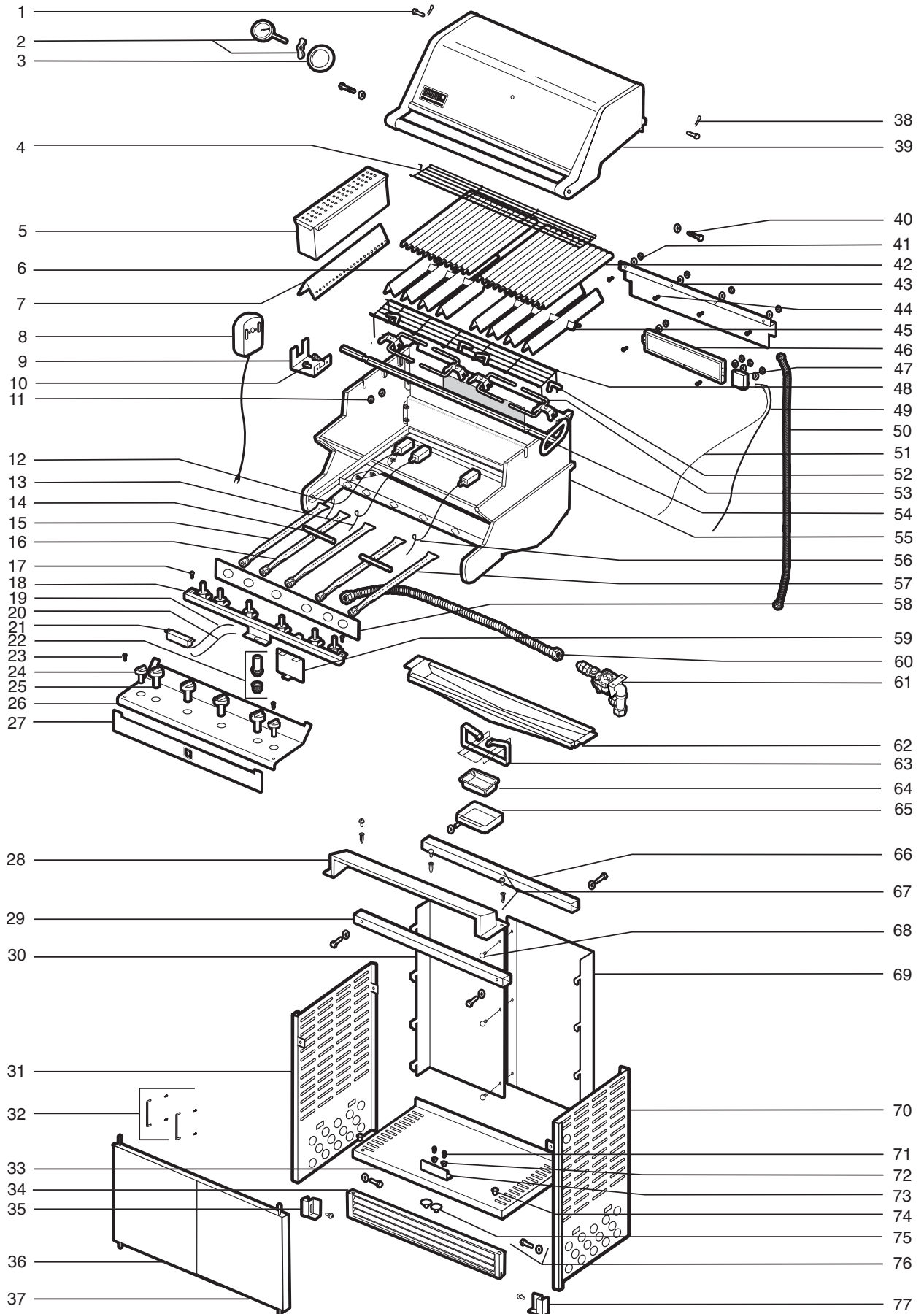

## EXPLODED VIEW LIST - PLATINUM D4

1. Hinge Pin
2. Thermometer Hardware
3. Thermometer Bezel
4. Warm-Up™ Basket
5. Smoker Assembly
6. Flavorizer® Bar Assembly w/ Smoker
7. Smoker Box Chip Grate
8. Rotisserie Motor
9. Motor Bracket
10. Motor Bracket Screw
11. 1/4 - 20 inch Keps Nut
12. Smoker Electrode Assembly  
(10 1/2 inch wire)
13. Electrode Assembly (8 3/4 inch wire)
14. Crossover® Tube
15. Smoker Burner Tube
16. Left Burner Tube
17. 10 - 24 x 1/2 inch Black Screw
18. Manifold
19. Negative Ignition Switch Wire
20. Positive Ignition Switch Wire
21. Four Output Ignition Module Assembly
22. Ignition Switch Button Assembly
23. 10 - 24 x 1/2 inch Black Screw
24. Small Control Knob
25. Control Knob
26. Control Panel
27. Front Panel
28. Vent Cover Assembly
29. Front Frame Rail
30. Left Rear Panel
31. Left Panel
32. Handle Assembly
33. Bottom Shelf
34. Toe Kick Vent
35. Left Vent Bracket
36. Left Door Assembly
37. Right Door Assembly
38. Hair Pin Cotter
39. Lid Assembly
40. 1/4 - 20 x 1 1/4 inch Bolt
41. IR Rain Cover Hardware
42. 12 inch Cook Grate
43. IR Rain Cover
44. 10 - 24 x 1/2 inch Stainless Steel Screw
45. Right Flavorizer® Bar Assembly
46. IR Burner
47. IR Cover Box
48. Warming Rack
49. Thermocouple
50. IR Gas Line
51. IR Electrode Wire
52. Rotisserie Fork Screw
53. Rotisserie Fork
54. Rotisserie Shaft
55. Cookbox Assembly
56. Electrode Assembly (16 1/4 inch wire)
57. Right Burner Tube
58. Heat Shield
59. Battery Shield Assembly
60. Main Gas Line
61. Bulkhead Assembly
62. Bottom Tray
63. Summit Catch Pan Holder
64. Summit Catch Pan
65. Summit Drip Pan
66. Rear Frame Rail
67. Rear Vent Hardware
68. Rear Panel Hardware
69. Right Rear Panel
70. Right Panel
71. 10 -16 x 3/4 Screw w/ Washer
72. Plastic Plug
73. Door Stop
74. Door Bushing
75. Door Plug
76. 1/4 - 20 x 1/2 inch Black Bolt
77. Right Vent Bracket

# EXPLODED VIEW - PLATINUM D6

5390501 - Summit® Platinum D6 NG Built-In 092005

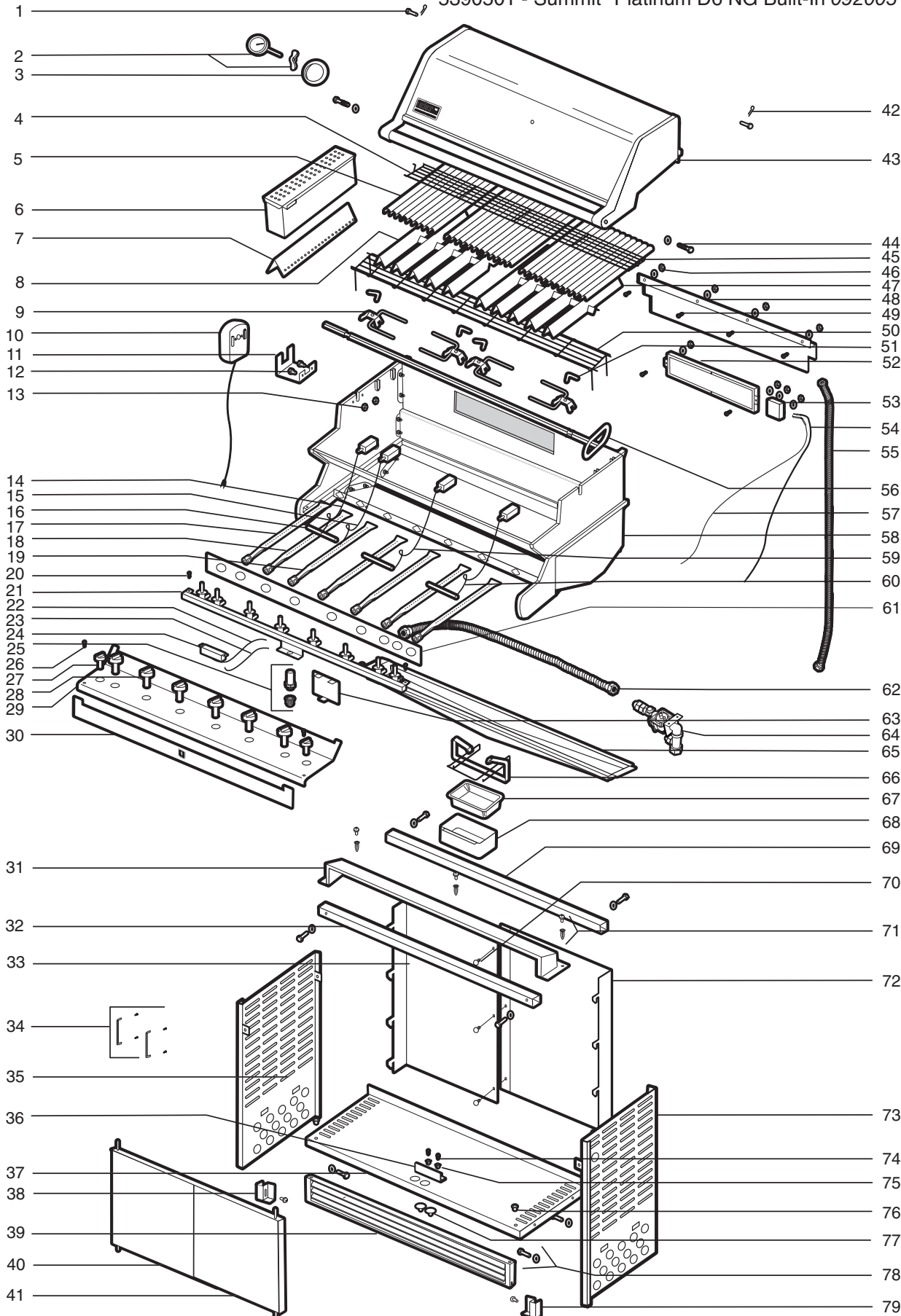

## EXPLODED VIEW LIST - PLATINUM D6

- |     |   |     |  |
|-----|---|-----|--|
| 1.  | Hinge Pin                                       | 40. | Left Door Assembly                       |
| 2.  | Thermometer Hardware                            | 41. | Right Door Assembly                      |
| 3.  | Thermometer Bezel                               | 42. | Hair Pin Cotter                          |
| 4.  | Warm-Up™ Basket                                 | 43. | Lid Assembly                             |
| 5.  | 8 inch Cooking Grate                            | 44. | 1/4 - 20 x 1 1/4 inch Bolt               |
| 6.  | Smoker Assembly                                 | 45. | 12 inch Cook Grate                       |
| 7.  | Smoker Box Chip Grate                           | 46. | IR Rain Cover Hardware                   |
| 8.  | Flavorizer® Bar Assembly w/ Smoker              | 47. | Right Flavorizer® Bar Assembly           |
| 9.  | Rotisserie Fork                                 | 48. | IR Rain Cover                            |
| 10. | Rotisserie Motor                                | 49. | 10 - 24 x 1/2 inch Stainless Steel Screw |
| 11. | Motor Bracket                                   | 50. | Warming Rack                             |
| 12. | Motor Bracket Screw                             | 51. | Rotisserie Fork Screw                    |
| 13. | 1/4 - 20 inch Keps Nut                          | 52. | IR Burner                                |
| 14. | Smoker Electrode Assembly<br>(10 1/2 inch wire) | 53. | IR Cover Box                             |
| 15. | Electrode Assembly (8 3/4 inch wire)            | 54. | Thermocouple                             |
| 16. | Crossover® Tube                                 | 55. | IR Gas Line                              |
| 17. | Smoker Burner Tube                              | 56. | Rotisserie Shaft                         |
| 18. | Left Burner Tube                                | 57. | IR Electrode Wire                        |
| 19. | Right Burner Tube                               | 58. | Cookbox Assembly                         |
| 20. | 10 - 24 x 1/2 inch Black Screw                  | 59. | Electrode Assembly (16 1/4 inch wire)    |
| 21. | Manifold  | 60. | Electrode Assembly (25 1/2 inch wire)    |
| 22. | Negative Ignition Switch Wire                   | 61. | Heat Shield                              |
| 23. | Positive Ignition Switch Wire                   | 62. | Main Gas Line                            |
| 24. | Six Output Ignition Module Assembly             | 63. | Battery Shield Assembly                  |
| 25. | Ignition Switch Button Assembly                 | 64. | Bulkhead Assembly                        |
| 26. | 10 - 24 x 1/2 inch Black Screw                  | 65. | Bottom Tray                              |
| 27. | Small Control Knob                              | 66. | Summit Catch Pan Holder                  |
| 28. | Control Knob                                    | 67. | Summit Catch Pan                         |
| 29. | Control Panel                                   | 68. | Summit Drip Pan                          |
| 30. | Front Panel                                     | 69. | Rear Frame Rail                          |
| 31. | Vent Cover Assembly                             | 70. | Rear Vent Hardware                       |
| 32. | Front Frame Rail                                | 71. | Rear Panel Hardware                      |
| 33. | Left Rear Panel                                 | 72. | Right Rear Panel                         |
| 34. | Handle Assembly                                 | 73. | Right Panel                              |
| 35. | Left Panel                                      | 74. | 10 -16 x 3/4 Screw w/ Washer             |
| 36. | Door Stop                                       | 75. | Plastic Plug                             |
| 37. | Bottom Shelf                                    | 76. | Door Bushing                             |
| 38. | Left Vent Bracket                               | 77. | Door Plug                                |
| 39. | Toe Kick Vent                                   | 78. | 1/4 - 20 x 1/2 inch Black Bolt           |
|     |   | 79. | Right Vent Bracket                       |



1

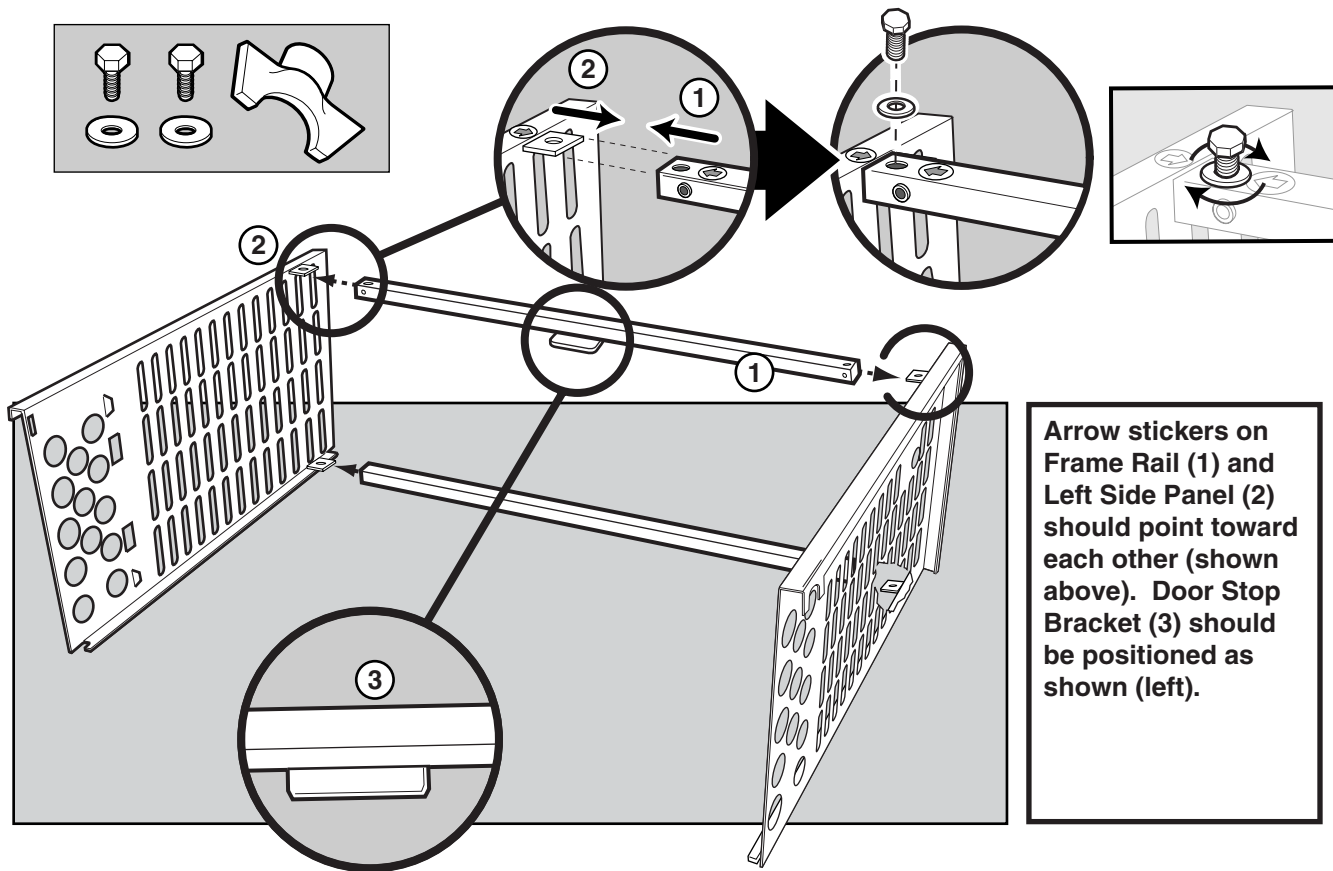
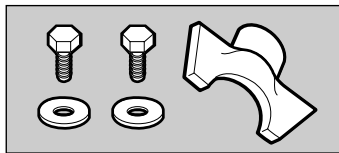

Arrow stickers on Frame Rail (1) and Left Side Panel (2) should point toward each other (shown above). Door Stop Bracket (3) should be positioned as shown (left).

2

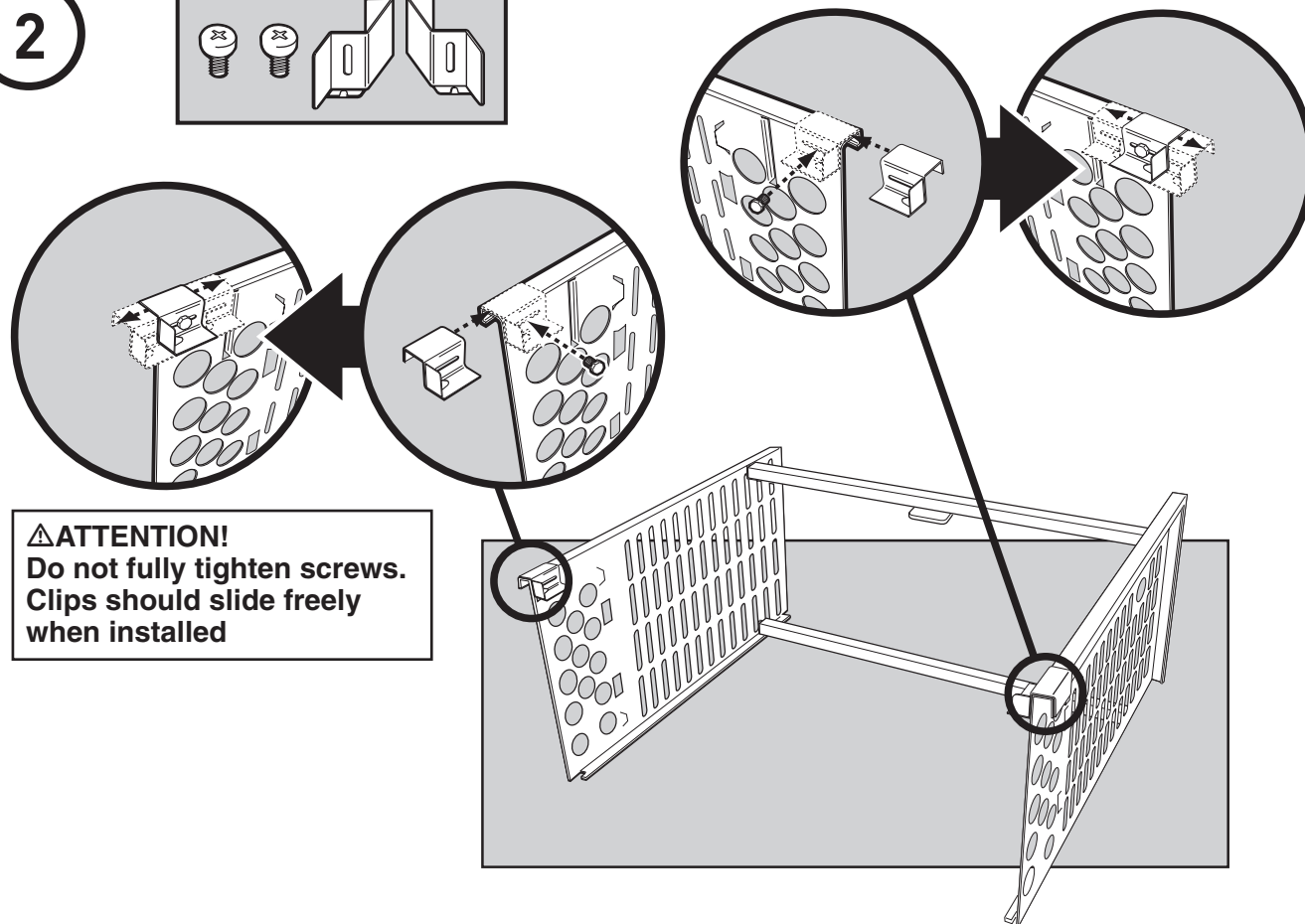
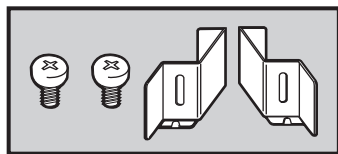

**⚠ATTENTION!**  
Do not fully tighten screws.  
Clips should slide freely  
when installed

3

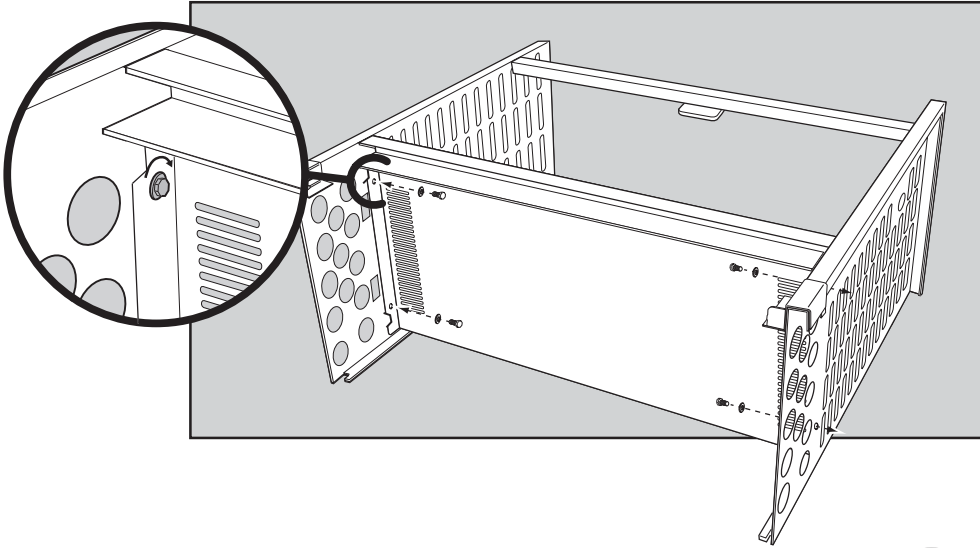
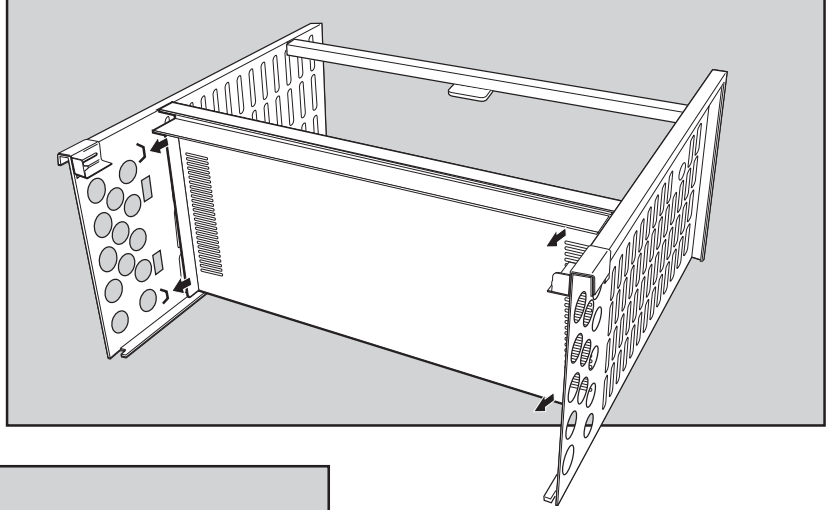
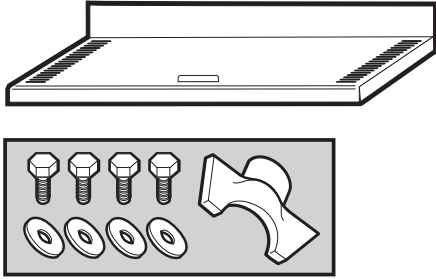

4

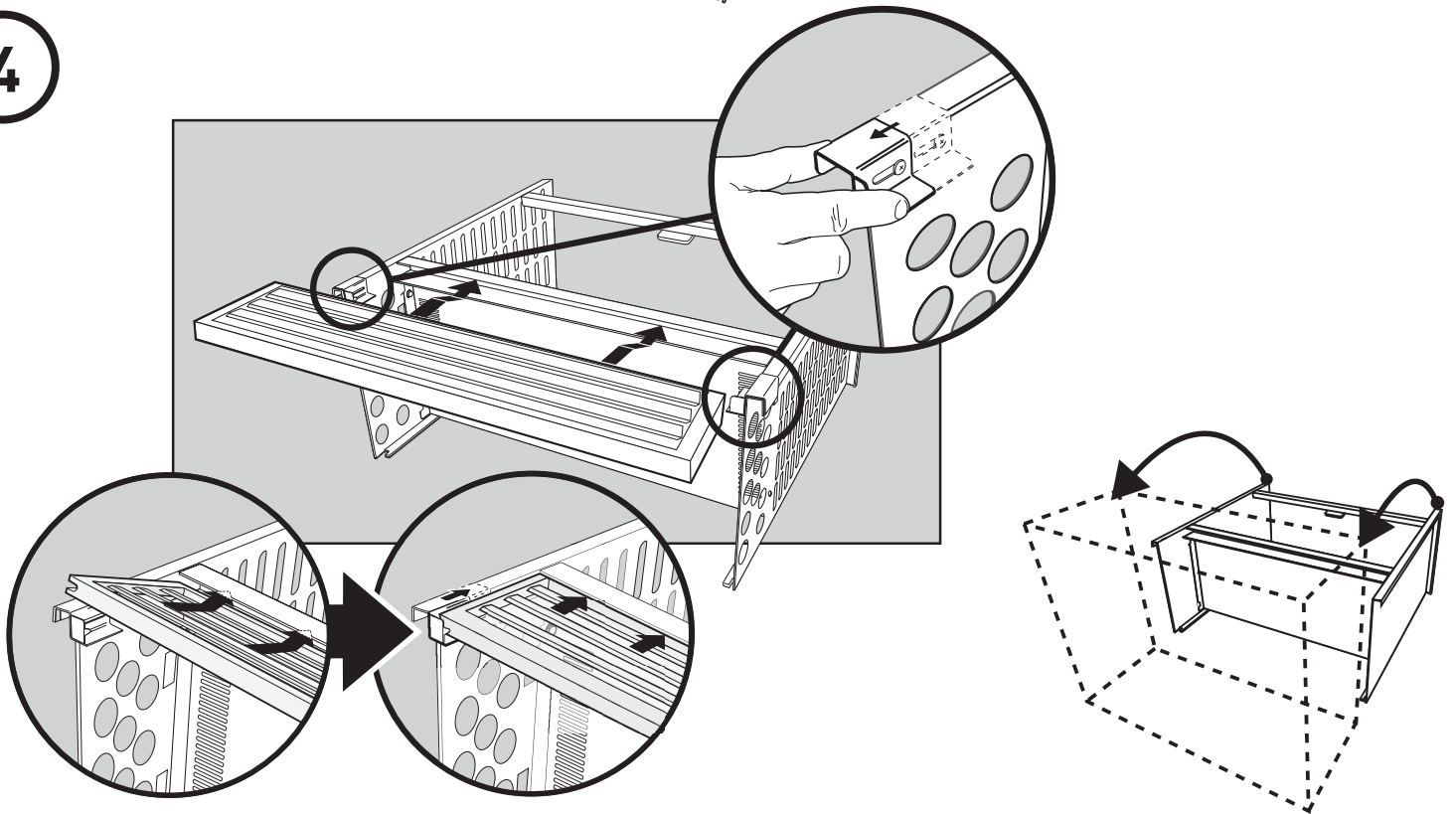

5

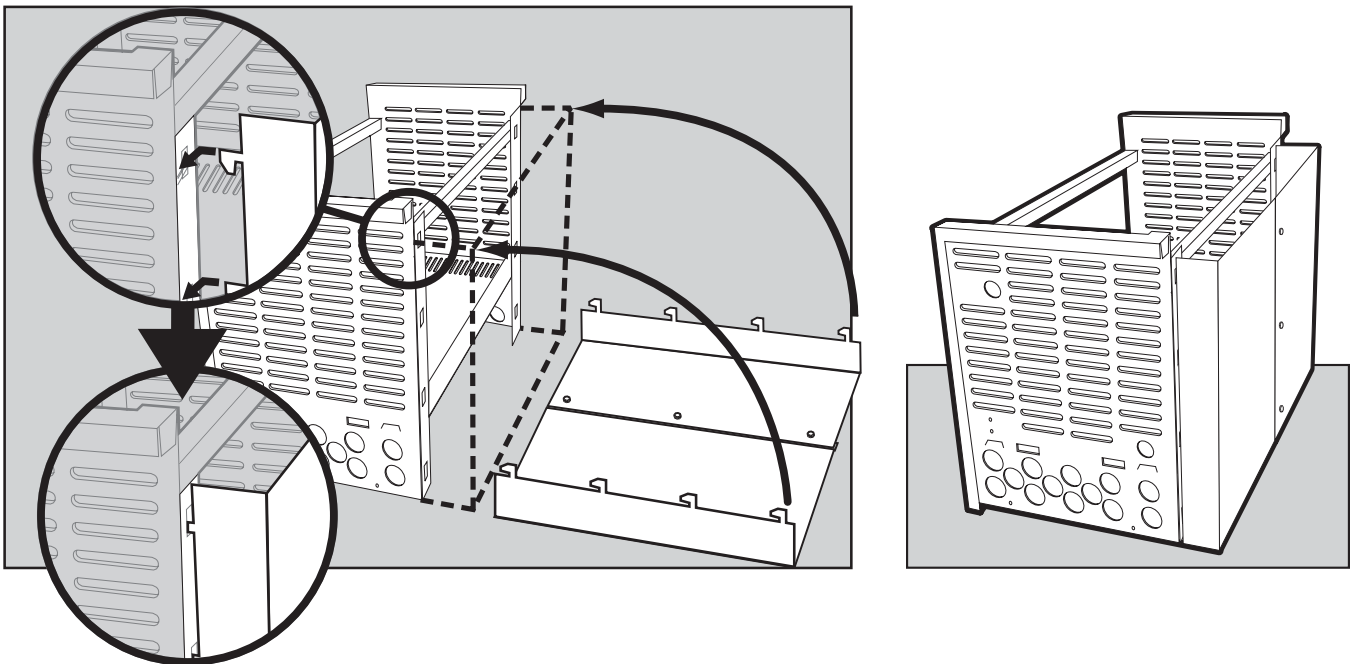
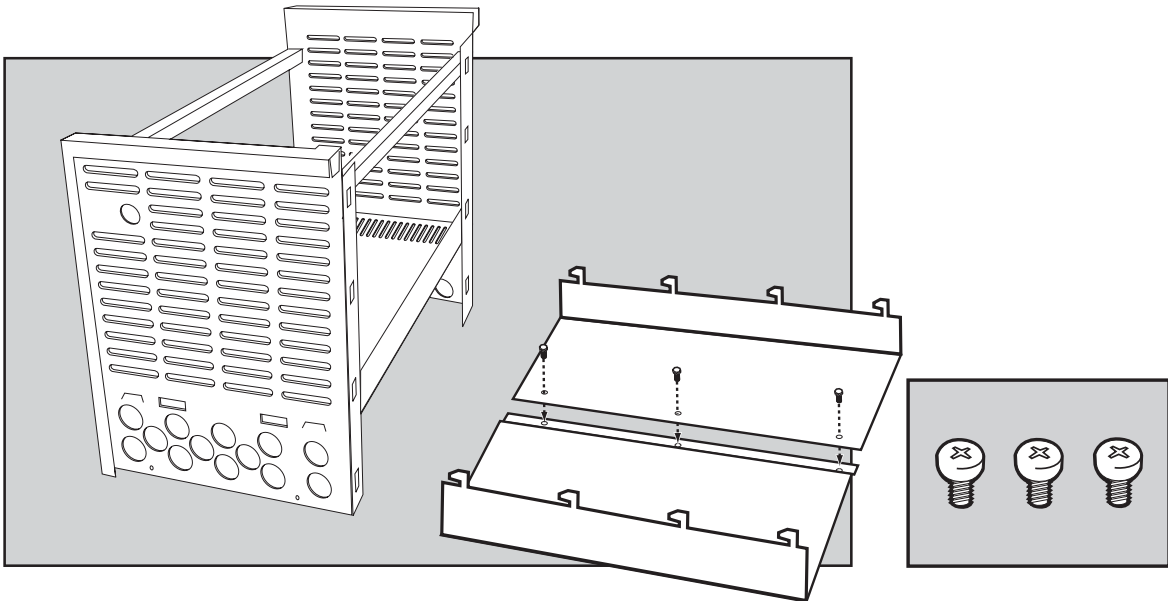
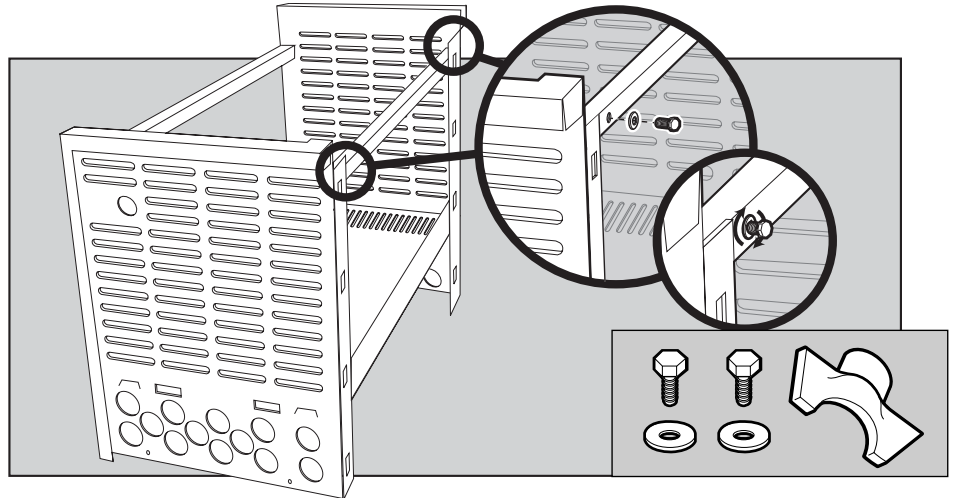
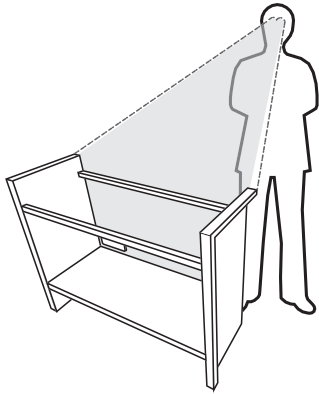

6



**⚠ CAUTION: Use two people to lift and install the Summit® Built-In frame assembly.**

- Lift the frame assembly into the "island" structure opening. Make sure the frame is resting level on the finished surface of the structure.
- Adjust the Front Vent to rest squarely on ground.
- Apply a bead of silicone sealant (1) around the perimeter and front edges of the grill that are in contact with the "island" structure. This will prevent moisture seepage. The sealant you use must have a temperature rating above 120°F (48.8° C).

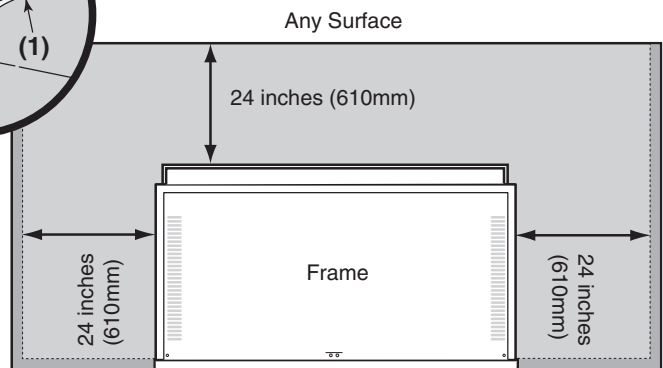
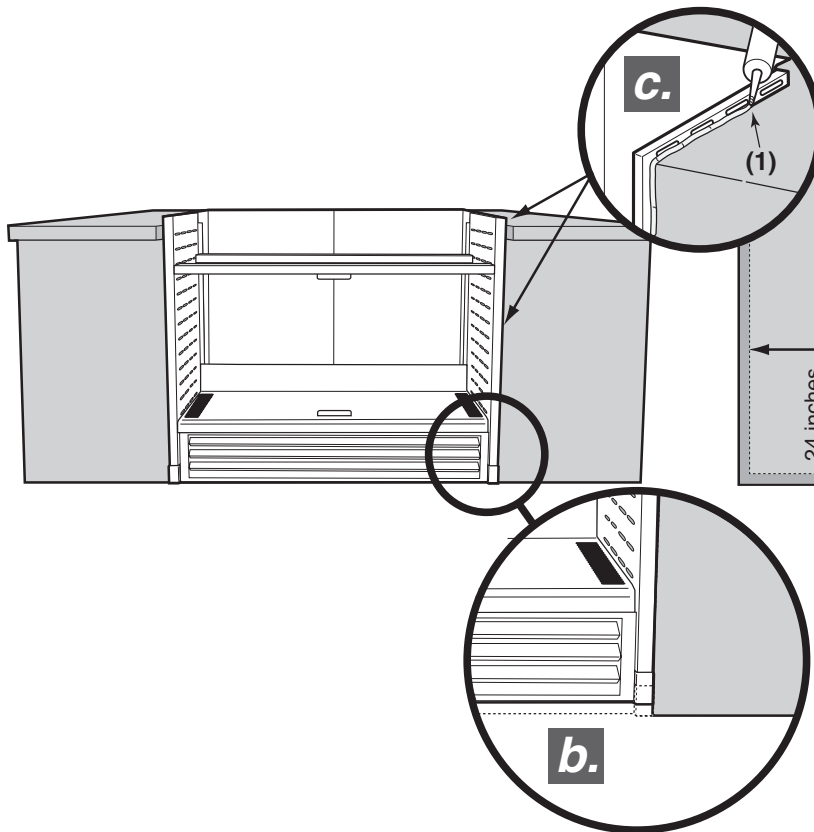
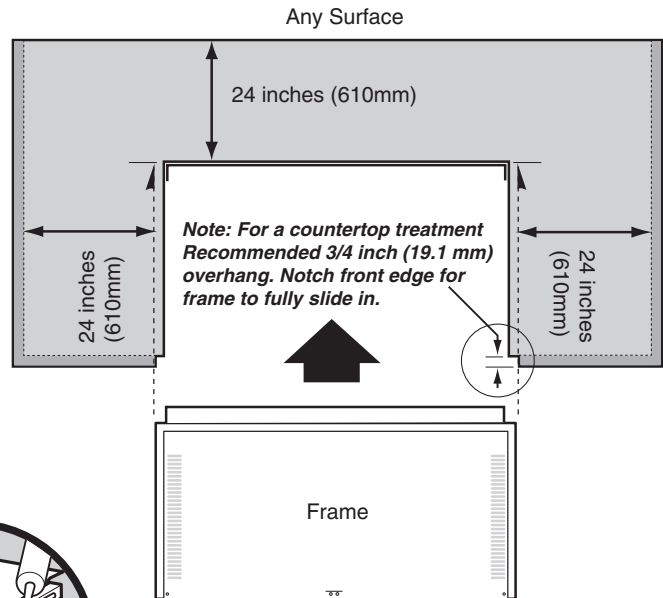
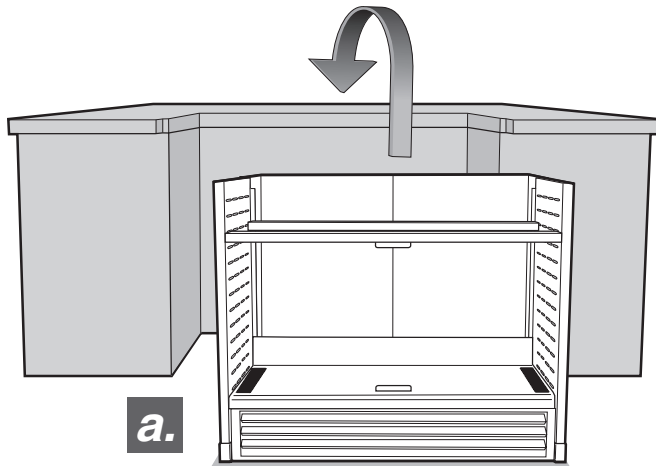

7

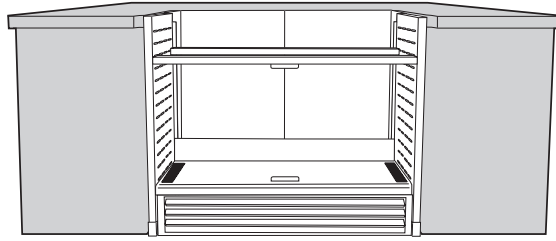

SUMMIT® 4B ○○○○

SUMMIT® 6B ○○○○○○

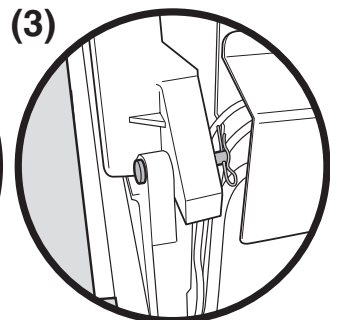
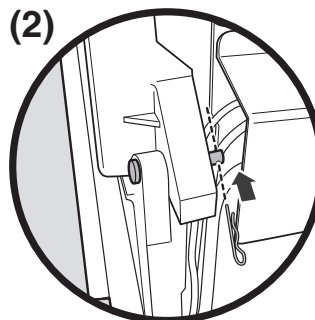
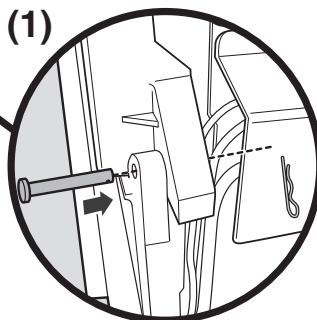
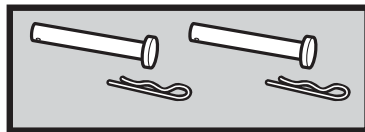
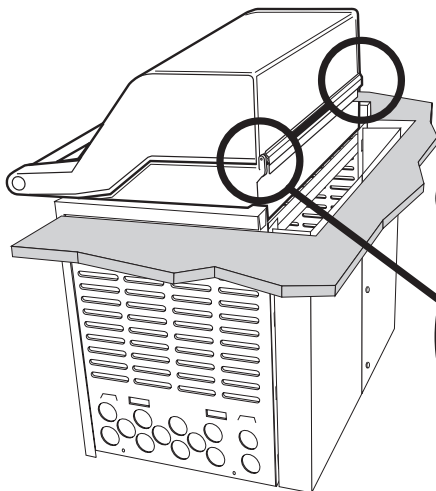
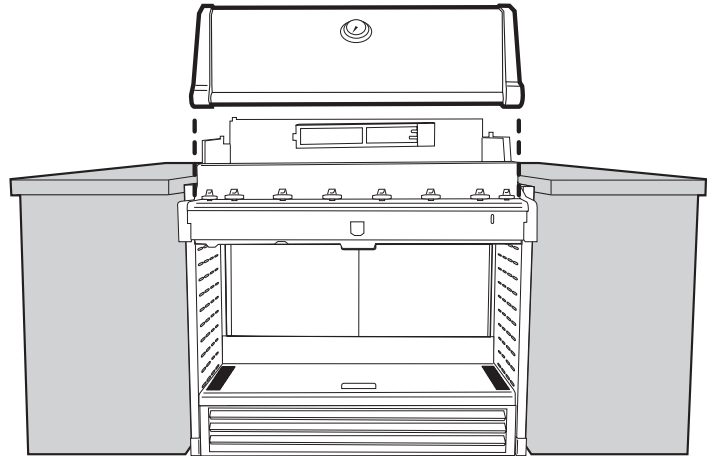
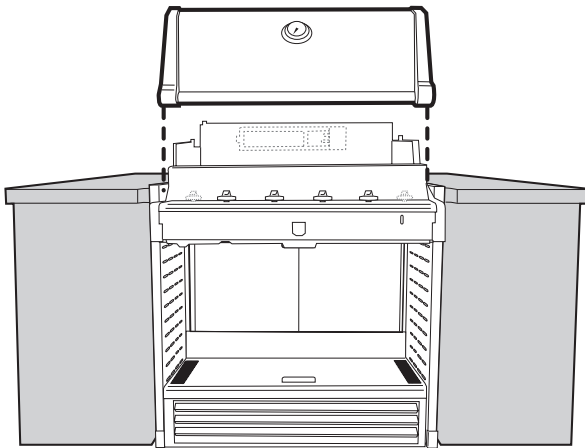
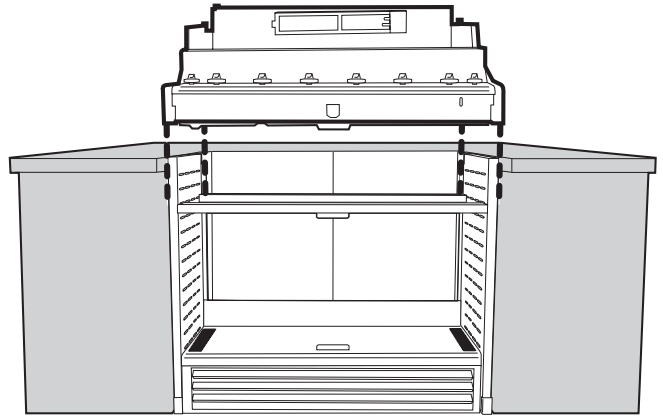
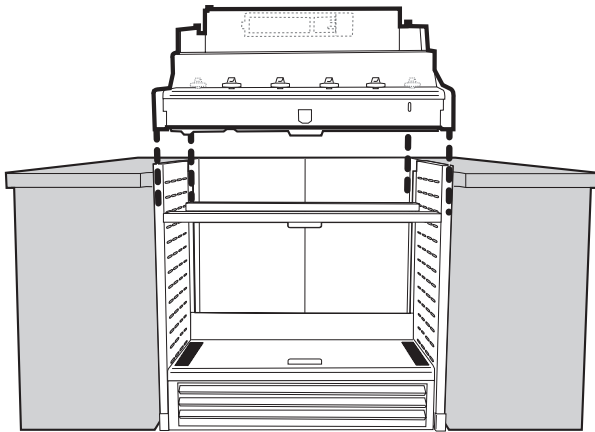

8

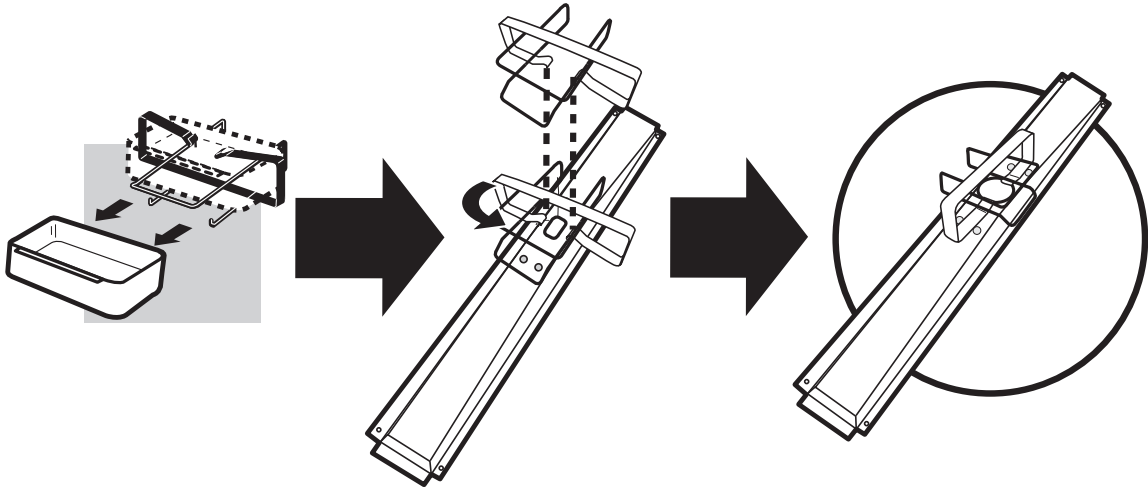

SUMMIT® 4B ○○○○

SUMMIT® 6B ○○○○○○

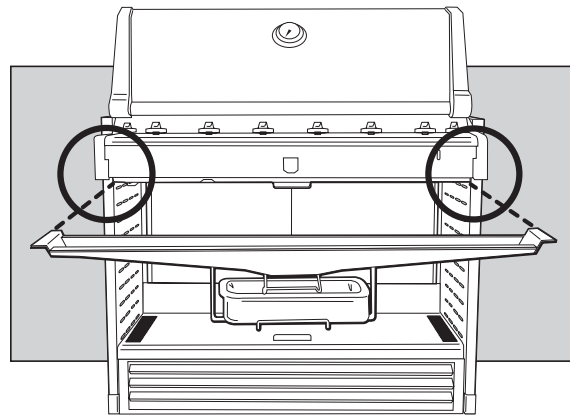
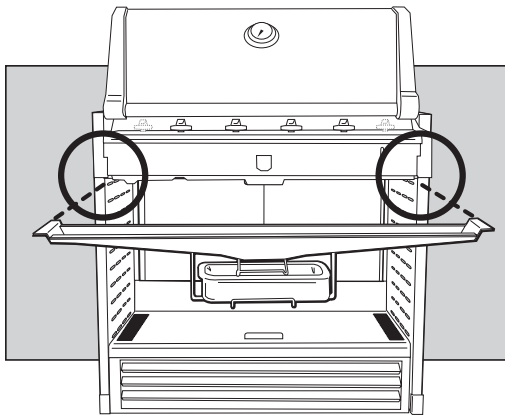

(1)

(2)

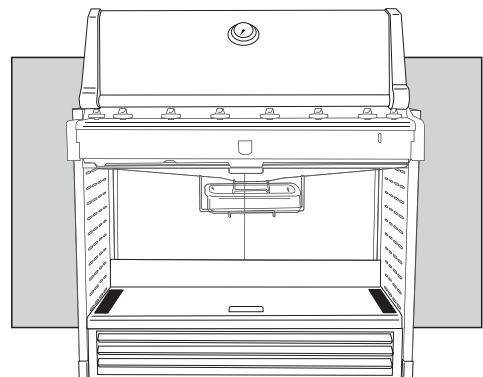
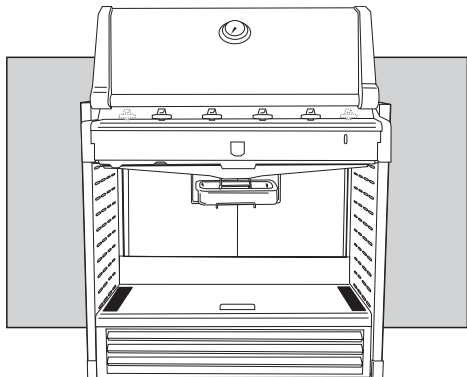
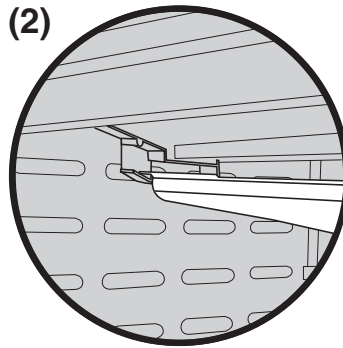
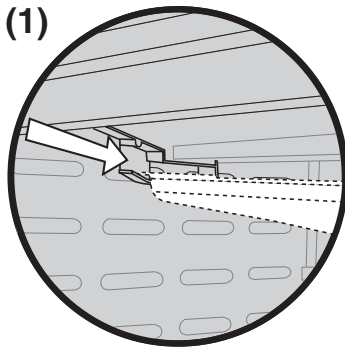

9

SUMMIT® 4B 🔥🔥🔥

SUMMIT® 6B 🔥🔥🔥🔥

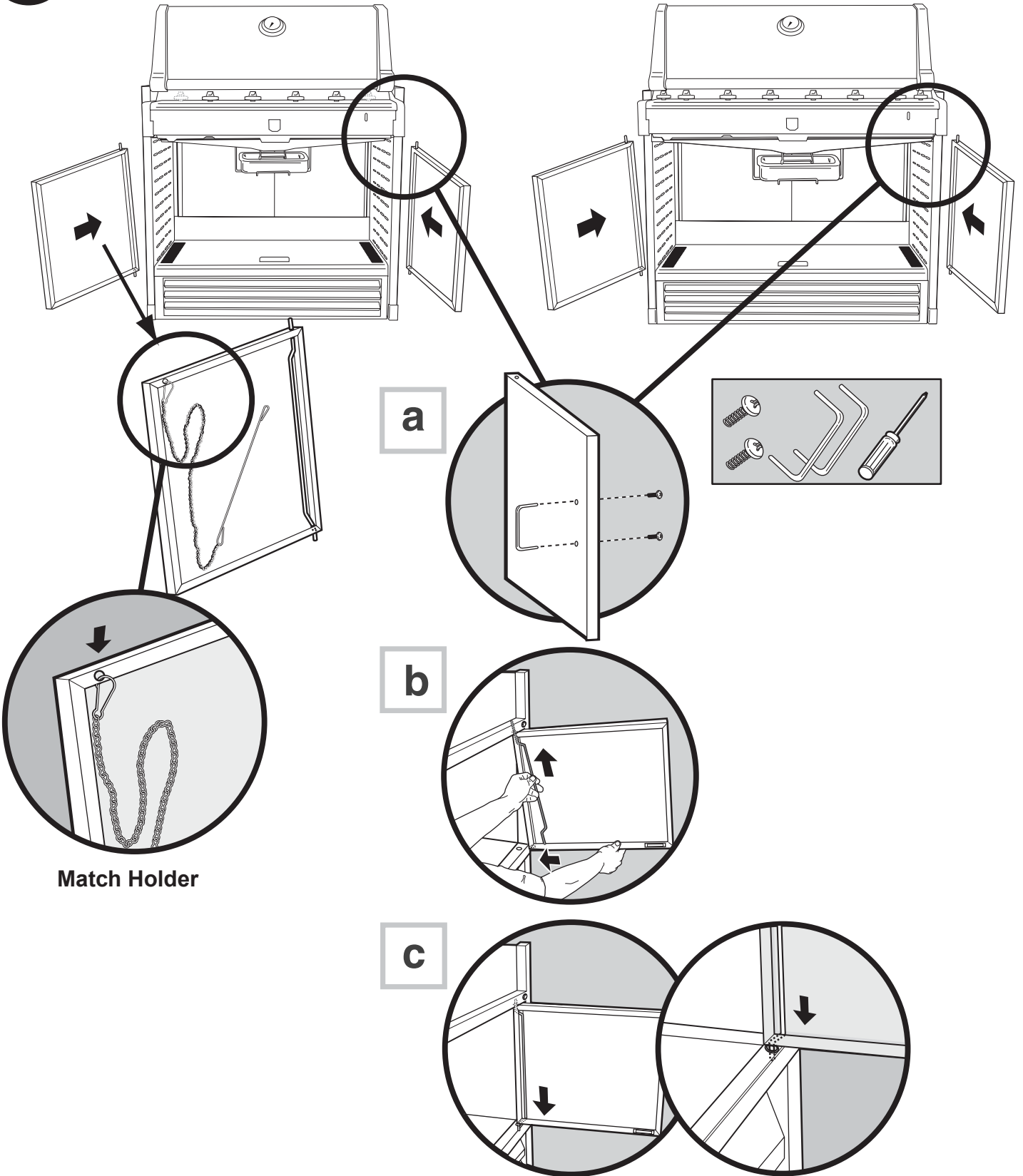

Match Holder

10

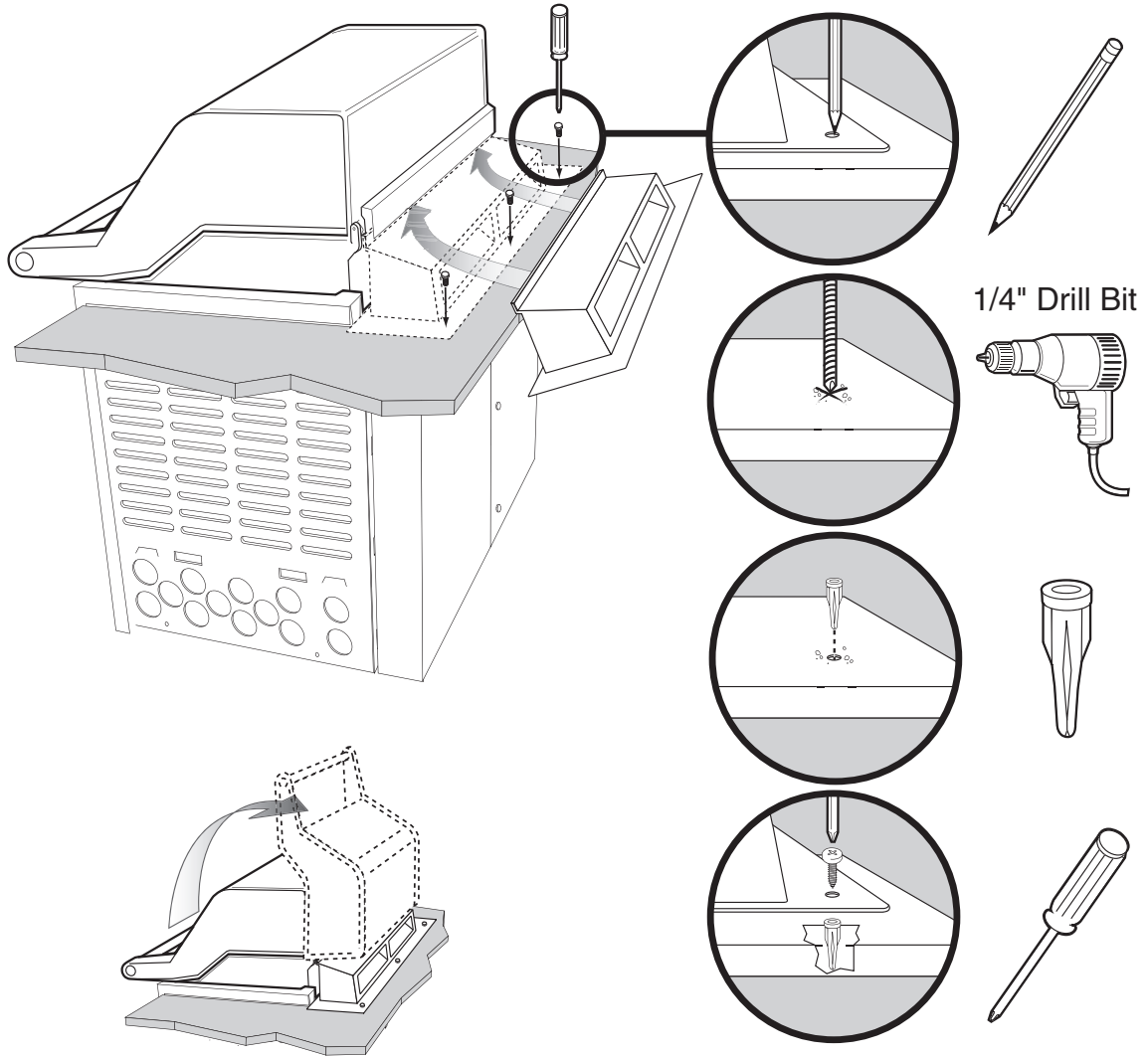

11

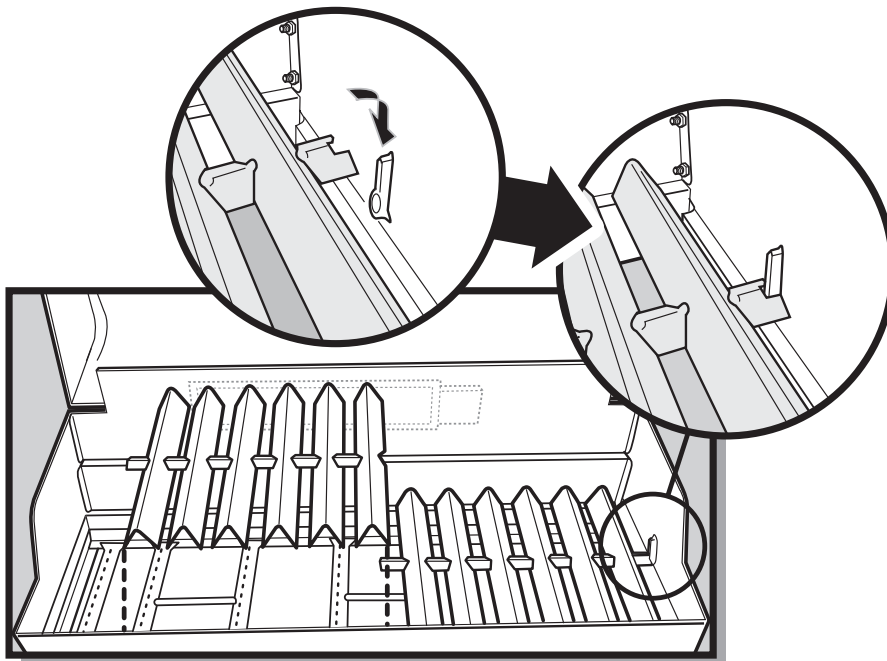



12

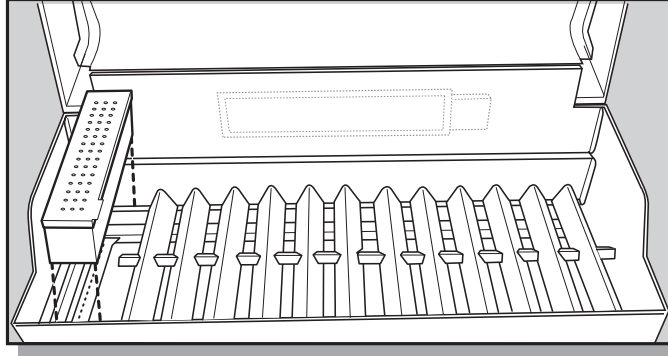

13

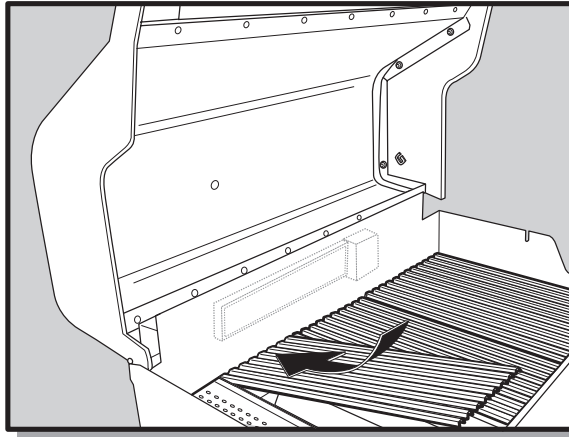

14

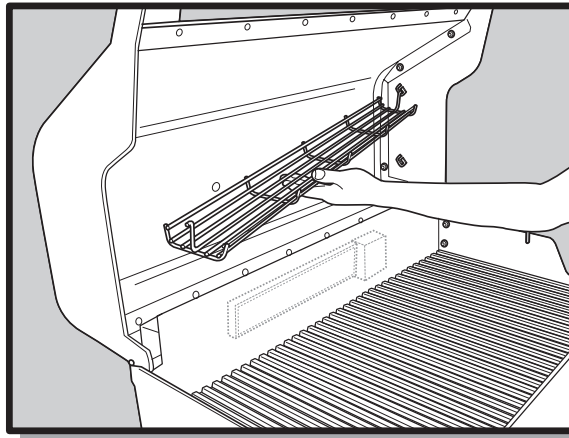

15

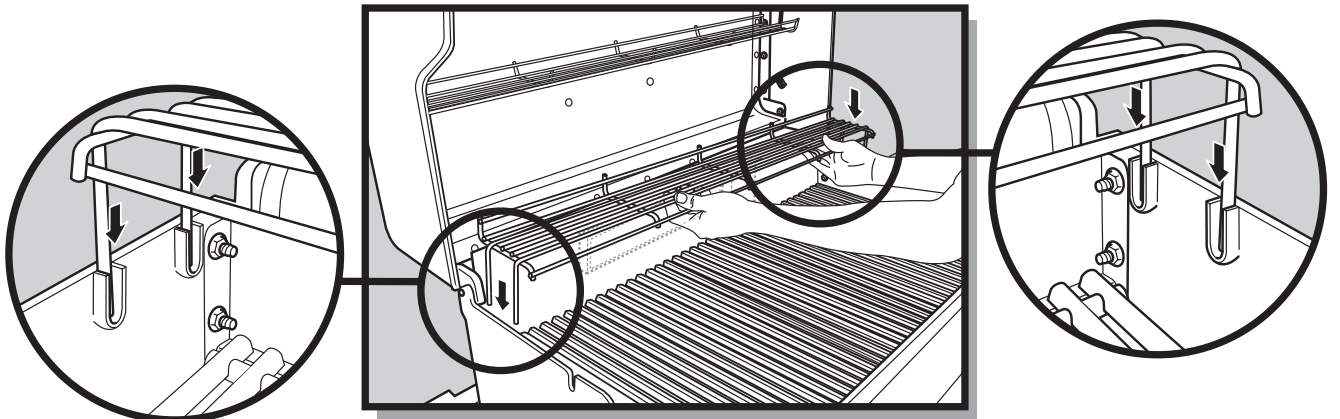

## BUILT-IN GAS LINE LOCATIONS

Note: Leave an access in the "island" structure for gas supply and regulator service that is not inside the grill structure. Weber® has a gas line and regulator access door (part # 36311) available from your dealer or call Customer Service at 1-800-446-1071.

Note: Area should be kept clear of sharp, jagged, or extremely abrasive surfaces to avoid possible damage to gas supply lines. Exercise caution when pulling gas lines through built-in structure.

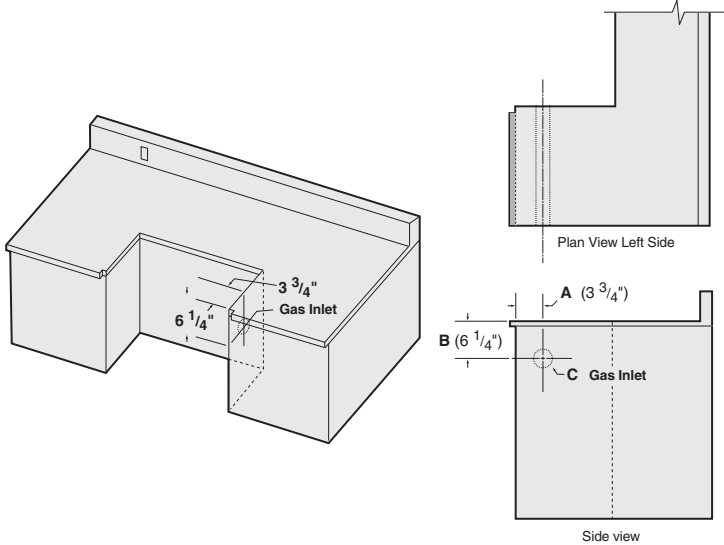

Dimensions	Built-In Gas Line Dimensions		
	Silver	Gold	Tolerances
A	3 3/4"	3 3/4"	+ 1/8" - 1/8"
B	6 1/4"	6 1/4"	+ 1/8" - 1/8"
C	2 1/2"	2 1/2"	+ 1/8" - 1/8"

## TYPICAL NATURAL GAS SUPPLY INSTALLATION

We recommend that this installation be done by a LICENSED professional.

### GENERAL SPECIFICATIONS FOR PIPING

Note - Contact your local municipality for building codes regulating outdoor gas grill installations. In absence of Local Codes, you must conform to the latest edition of National Fuel Gas Code ANSI Z223.1/NFPA54.

- This grill is designed to operate at 4.5 inches of water column pressure.
- A manual shut-off valve must be installed outdoors, and be accessible, not in the "built-in" structure. An additional manual shut-off valve indoors should be installed in the branch fuel line in an accessible location near the supply line.

### ⚠ CAUTION: If young children are in the area, a locking valve should be considered.

- Pipe compound should be used which is resistant to the action of liquid propane gas when gas connections are made.
- The gas connections must be firmly attached to a rigid, permanent construction.

Note: The information provided in this manual is general for typical installations. We cannot cover all possible installation ideas. We recommend, prior to installation, that you contact your municipality for local building codes and your local fire department for installation verification.

If you have any questions, contact Customer Service at 1-800-446-1071.

Nominal Iron Pipe Size (Inches)	Internal Diameter (Inches)	Length of Pipe (Feet)													
		10	20	30	40	50	60	70	80	90	100	125	150	175	200
1/4	.364	32	22	18	15	14	12	11	11	10	9	8	8	7	6
3/8	.493	72	49	40	34	30	27	25	23	22	21	18	17	15	14
1/2	.622	132	92	73	63	56	50	46	43	40	38	34	31	28	26
3/4	.824	278	190	152	130	115	105	96	90	84	79	72	64	59	55
1	1.049	520	350	285	245	215	195	180	170	160	150	130	120	110	100
1 1/4	1.380	1050	730	590	500	440	400	370	350	320	305	275	250	225	210
1 1/2	1.160	1600	1100	890	760	670	610	560	530	490	460	410	380	350	320
2	2.067	3050	2100	1650	1450	1270	1150	1050	990	930	870	780	710	650	610
2 1/2	2.469	4800	3300	2700	2300	2000	1850	1700	1600	1500	1400	1250	1130	1050	980
3	3.068	8500	5900	4700	4100	3600	3250	3000	2800	2600	2500	2200	2000	1850	1700
4	4.026	17500	12000	9700	8300	7400	6800	6200	5800	5400	5100	4500	4100	3800	3500

## GAS LINE PIPING

- Refer to the piping chart at the bottom of previous page.
- The corrugated gas line from the manifold is 58 inches long. Do not extend the gas line.
- We have provided the means to make an SAE 45° flare connection. Do not use pipe sealant on this connection.
- If the length of line required does not exceed 50 feet, use a 5/8" O.D. tube. One size larger should be used for lengths greater than 50 feet. Refer to piping chart.
- Gas piping may be copper tubing, type K or L; polyethylene plastic tube, with a minimum wall thickness of .062 inch; or standard weight (schedule 40) steel or wrought iron pipe.
- Copper tubing must be tin-lined if the gas contains more than 0.3 grams of hydrogen sulfide per 100 cubic feet of gas.
- Plastic tubing is suitable only for outdoor, underground use.
- Gas piping in contact with earth, or any other material which may corrode the piping, must be protected against corrosion in an approved manner.
- Underground piping must have a minimum of 18" cover.

## TEST CONNECTIONS

All connections and joints must be thoroughly tested for leaks in accordance with local codes and all listed procedures in the latest edition of the National Fuel Gas Code ANSI Z223.1/NFPA 54.

**⚠ DANGER**

**Do not use an open flame to check for gas leaks. Be sure there are no sparks or open flames in the area while you check for gas leaks. This will result in a fire or explosion which can cause serious bodily injury or death, and damage to property.**

## CONNECT GAS SUPPLY

A 58 inch corrugated gas line is supplied with the grill. This line needs to pass through the gas inlet opening to the main gas supply.

- 1) Connect the corrugated gas line to the regulator **(a)**. Use the 1/2" flared gasket **(1)** to ensure proper seal. **(b)** Shows the gas line and regulator assembled.
- 2) Uncap the flare fitting connection off the regulator.
- 3) Hard pipe the gas supply to the inlet of the regulator. Refer to "Typical Gas Supply Installation".

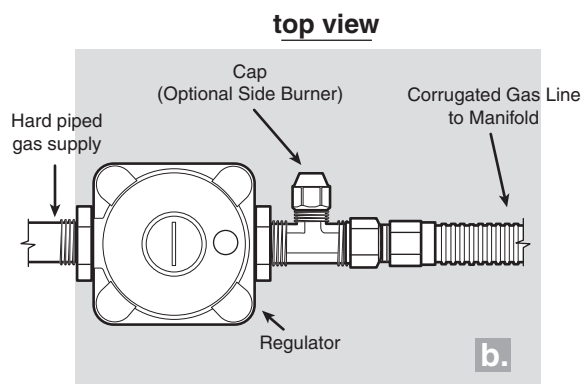
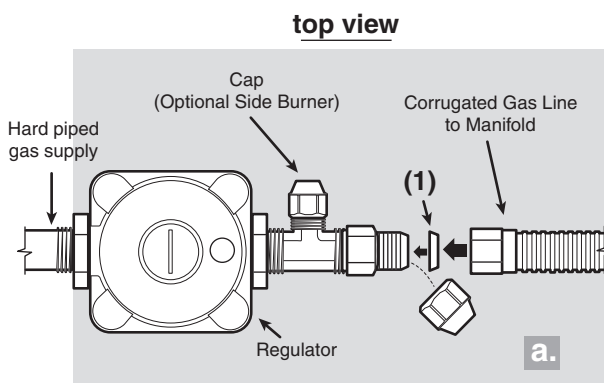

**⚠ ATTENTION:** This product has been safety tested and is only certified for use in a specific country. Refer to label located on outer carton for country designation.

These parts may be gas carrying or gas burning components. Please contact Weber-Stephen Products Co., Customer Service Department for genuine Weber-Stephen Products Co. replacement part(s) information.

**⚠ WARNING:** Do not attempt to make any repair to gas carrying or gas burning components without contacting Weber-Stephen Products Co., Customer Service Department. Your actions, if you fail to follow this product Warning, may cause a fire or an explosion resulting in serious personal injury or death and damage to property.

- 4) Connect the corrugated gas line to the manifold located on the right hand side of grill under the control panel. Use the 1/2" flared gasket (1) to ensure proper seal.

*Note: Leave an access in the "island" structure for gas supply and regulator service not inside the grill structure. Weber® has a gas line and regulator access door (part # 36311) available from your dealer or call Customer Service at 1-800-446-1071.*

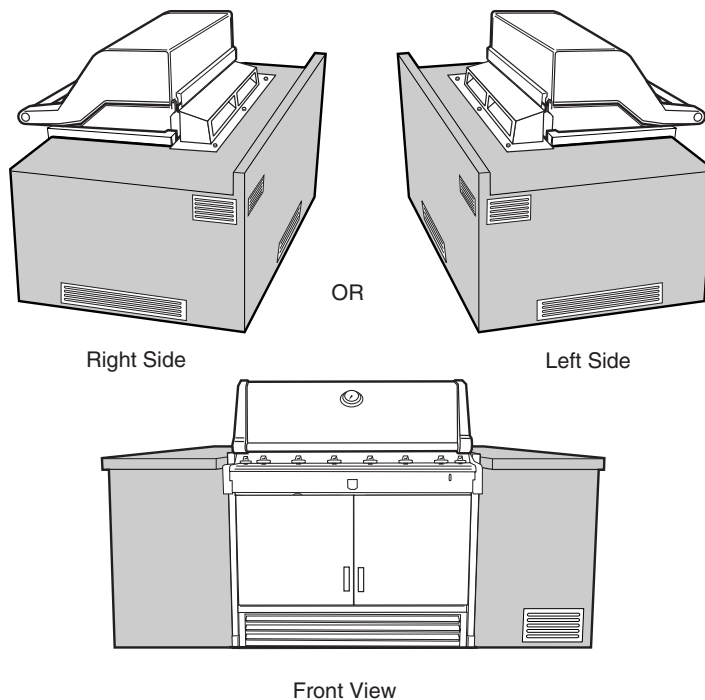
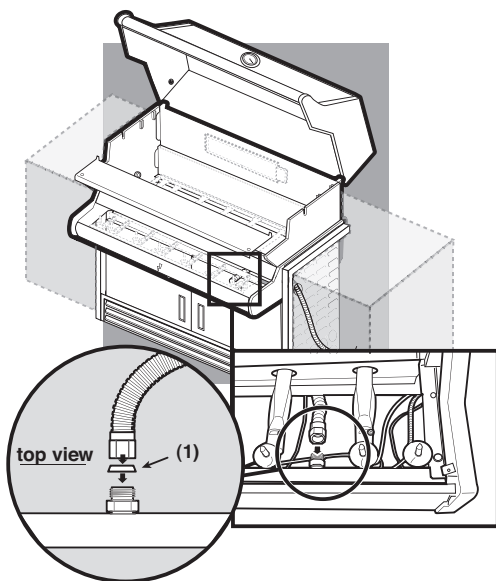

## VENTILATION

**⚠ WARNING: Air holes must be provided in the structure at the top and bottom to provide ventilation in the event of a gas leak.**

Air holes can be located in a low visibility area and should be protected by screening material to prevent rodents and insects from entering the structure. Air holes will also help dry moisture.

Summit® Built-In cabinet vents are available from your dealer or call Customer Service at 1-800-446-1071.

*Note: These drawings are only a reference.*

- Cross ventilation must be incorporated in the supporting structure. We recommend a minimum of 100 square inches of venting per side.
- Vents should be on two sides of the structure.
- The above drawings are for reference only.
- Location of the vents should be from the center, outward.
- Locate the vents at both the bottom of the structure and at the top of the structure.
- The bottom vents should be as close to ground level as possible. Make sure the vent area is not blocked by interior supports of the structure.
- We recommend vents with screens.
- Access doors to the structure are not considered vents.
- Clean the vents periodically.

**⚠ DANGER: Failure to follow recommended minimum venting instructions can cause gas to collect in the structure in the event of a gas leak. This may result in a fire or an explosion which can cause serious bodily injury or death, and damage to property.**



WEBER-STEPHEN PRODUCTS CO.  
www.weber.com®

©2003 The following trademarks are registered in the name of Weber-Stephen Products Co., an Illinois corporation, located at 200 East Daniels Road, Palatine, Illinois 60067 U.S.A. Australia; Smokey Joe, Weber, Kettle Silhouette®, Genesis, Austria; Kettle Silhouette®, Smokey Joe, Weber, Benelux; Kettle Silhouette®, Smokey Joe, Weber, Compact Grill Configuration, Botswana; Weber, Canada; Smokey Joe, Genesis, China; Kettle Silhouette®, Denmark; Kettle Silhouette®, Smokey Joe, Weber, Finland; Smokey Joe, France; Kettle Silhouette®, Smokey Joe, Weber, One-Touch, Germany; Smokey Joe, Weber, One-Touch, Greece; Smokey Joe, Ireland; Kettle Silhouette®, Smokey Joe, Italy; Smokey Joe, Weber, Japan; Smokey Joe, Weber, Korea; Smokey Joe, Weber, New Zealand; Weber, Smokey Joe, Nigeria; Weber, Norway; Smokey Joe, Weber, Portugal; Weber, South Africa; Smokey Joe, Weber, Kettle Configuration, Spain; Smokey Joe, Weber, Sweden; Kettle Silhouette®, Smokey Joe, Switzerland; Kettle Silhouette®, Smokey Joe, Weber, United Kingdom; Smokey Joe, Weber, Weber One-Touch, U.S.A.; Kettle Configuration, Kettle Silhouette®, Smokey Joe, Weber, One-Touch, Firespice, Go-Anywhere, U.S.A.; Kettle Configuration, Kettle Silhouette, Genesis, Flavorizer, Crossover, Flango, Performer, Rapidfire, Tuck 'N Carry, Jumbo Joe, Bar-B-Kettle, Master-Touch, Spirit, Grill Out, Summit, Platinum, 1-800-Grill-Out, Ranch, Matchless Flame, Zimbabwe; Weber, Kettle Configuration, Kettle Silhouette®.