



# PERFORMER™

## Owner's Manual



**NOTICE TO INSTALLER:** These instructions must be left with the owner and the owner should keep them for future use.

**THIS BARBECUE IS DESIGNED FOR OUTDOOR USE ONLY.**

**WARNING:** Do not try to light this appliance without reading "Lighting" instructions section of this manual.



## **DANGER**

Failure to follow the Dangers, Warnings and Cautions contained in this Owner's Manual may result in serious bodily injury or death, or in a fire causing damage to property.

## **WARNINGS**

---

- Do not use in high winds.
- Do not use gasoline, alcohol, or other highly volatile fluids to ignite charcoal. Use a commercially prepared firestarter, such as Weber FireStarters, and make sure that, if using lighter fluid, any fluid that may have drained through the bottom vents is removed before lighting the charcoal.
- Kettle should be kept in a level position at all times.
- Infants, children, and pets should never be left unattended near a hot kettle.
- The kettle should never be used within five feet of any combustible material.
- Do not wear clothing with loose flowing sleeves while barbecuing.
- Never use kettle unless all parts of the unit are in place. Make sure ash catcher is in place when using the barbecue.
- Charcoal starter fluid should never be added to hot or even warm coals. After use, starter fluid should be capped and placed a safe distance from kettle.
- The lid should be removed from the kettle while lighting and getting fire started.
- Do not line bowl of kettle with aluminum foil - it may obstruct flow of air. Instead, use a drip pan to catch drippings from meat when cooking by the Indirect Method.
- Always put charcoal in Char-Baskets or on top of the lower grate (charcoal grate) and not directly into the bottom of the bowl.
- During cooking, the ashes may contain hot coals. Remove ashes only after all coals have completely burned out and are fully extinguished.
- Do not place a hot lid on carpet or grass. Use the steel lid holder provided.
- Never attempt to move a hot kettle.
- Do not add charcoal impregnated with lighter fluid while cooking.
- Never touch grates or kettle to see if they are hot.
- Do not use water to control flare-ups or extinguish coals, as it may damage the porcelain finish; slightly close bottom air vents, instead. Close all vents completely after putting the lid on the bowl when you are finished cooking to extinguish the fire or coals.
- Use proper barbecue tools with long heat-resistant handles.
- Barbecue mitts should always be worn to protect hands while barbecuing.
- Never dump hot coals where someone may step on them or where they might start a fire. Do not remove coals until fully extinguished and cold.
- Hot electric starters should be handled carefully and put in a safe place after use. Electric cords should be placed away from walkways. Keep electric cords away from hot surfaces.
- Do not use sharp objects of any kind to clean cooking grate or remove ashes.
- Do not use abrasive cleaners on kettle or cooking grate.
- To adjust vents or to remove lid while barbecuing, use barbecue mitts or a hot pad.
- When using liquid starters always check ash catcher before lighting. Any accumulation of starter fluid in the ash catcher could ignite, resulting in a fire below the bowl. Wipe out any fluid before igniting charcoal.

# WARRANTY

---

Weber Stephen Products Co. (Weber) hereby warrants to the ORIGINAL RETAIL PURCHASER of this Weber Barbecue that if it is assembled and operated in accordance with the printed instructions accompanying it then for a period of one (1) year from the date of purchase, the cooking grate, charcoal grate, and Char-Basket™ Fuel Holders shall be free from defects in material and workmanship; and for five (5) years from the date of purchase, all other parts shall be free from defects in material and workmanship.

Weber may require reasonable proof of your date of purchase. THEREFORE, YOU SHOULD RETAIN YOUR SALES SLIP OR INVOICE AND RETURN THE WEBER LIMITED WARRANTY REGISTRATION CARD IMMEDIATELY.

This Limited Warranty shall be limited to the repair or replacement of parts which prove defective under normal use and service and which on examination shall indicate, to Weber's satisfaction, they are defective. Any part that is claimed to be defective and covered by this Limited Warranty must be returned with transportation charges prepaid to Weber-Stephen Products Co., Customer Service Center, 250 S. Hicks Rd., Palatine, IL, 60067-6241. If Weber's inspection confirms the defect and the claim, Weber will repair or replace such part without charge and return it to you freight or postage prepaid.

This Limited Warranty does not cover any failures or operating difficulties due to accident, abuse, misuse, alteration, misapplication, improper installation or improper maintenance or service, or failure to perform normal and routine maintenance as set out in this owner's manual.

Deterioration or damage due to severe weather conditions such as hail, hurricanes, earthquakes or tornadoes, discoloration due to exposure to chemicals either directly or in the atmosphere, is not covered by this Limited Warranty.

There are no other express warrants except as set forth herein and any applicable implied warranties of merchantability and fitness are limited in duration to the period of coverage of this express written Limited Warranty. Some states do not allow limitation on how long an implied warranty lasts, so this limitation may not apply to you.

Weber is not liable for any special, indirect or consequential damages. Some states do not allow the exclusion or limitation of incidental or consequential damages, so this limitation or exclusion may not apply to you.

Weber does not authorize any person or company to assume for it any other obligation or liability in connection with the sale, installation, use, removal, return, or replacement of its equipment; and no such representations are binding on Weber.

This Warranty applies only to products sold at retail.

**WEBER-STEPHEN PRODUCTS CO.**  
**Customer Service Center**  
**250 South Hicks Road**  
**Palatine, IL 60067-6241**  
**(800) 446-1071**

# PATENTS AND TRADEMARKS

---

© 1996 Weber.  , Weber, the kettle configuration, Go-Anywhere, Smokey Joe, Flavorizer, One-Touch, Genesis, Crossover, FireSpice, Grill Works and WeberGrabbers are registered U.S. trademarks; Tuck-N-Carry, Outrider, Master-Touch, Bar-B-Kettle, Tuck-Away, Char-Basket, The Ranch, Smokey Mountain Cooker, Performer, Touch-N-Go, CharBin, Perma-Mount, Gas Catcher, Spider Stopper, Steam-N-Chips, Warm-Up, FlameCheck, Corn-N-Tater and Grill Out! are U.S. trademarks of Weber-Stephen Products Co., 200 East Daniels Road, Palatine, IL 60067-6266. Sidekick is a registered U.S. trademark of Bemis Manufacturing Co.

Genesis Gas Barbecues are covered under U.S. patent #4,677,964, #4,727,853, #4,860,724, #4,941,817, #4,829,978, #D293,067 and other patents pending. Wheels are covered under U.S. patent #D249,678. One-Touch is covered under U.S. patent #RE33,091 and #4,576,140. Master-Touch, Performer and The Ranch are covered under U.S. patent #4,777,927, #4,966,125 and other patents pending. Smokey Joe is covered under U.S. patent #4,498,452 and #D278,021. Outrider and Smokey Joe Tuck-N-Carry are covered under U.S. patent #4,836,179. Gas Go-Anywhere is covered under U.S. patent #4,627,408. FirePlace is covered under U.S. patent #D293,191. Contemporary Tools are covered under U.S. patent #D299,997, #D298,792 and #D299,996. Corn-N-Tater Holder is covered under U.S. patent #4,458,585, #D280,282 and #D291,855. Sidekick is covered under U.S. patent #4,337,751. Grill Works is covered under U.S. patent #4,942,862.

Smokey Joe is a registered Canadian trademark. In Canada, Genesis Gas Barbecues are covered under Rd 1987 Reg. #58,034 and patent #1,279,540. One-Touch Kettle is covered under patent #1,168,124. Printed in the U.S.A.

# Contents

<b>WARNINGS</b> .....	3
Warranty & Patents.....	4-5
General Instructions.....	7
Assembly .....	8-15
Operating Instructions	
Lighting.....	16
Cleaning .....	16
Cooking .....	17
Parts Listing .....	19

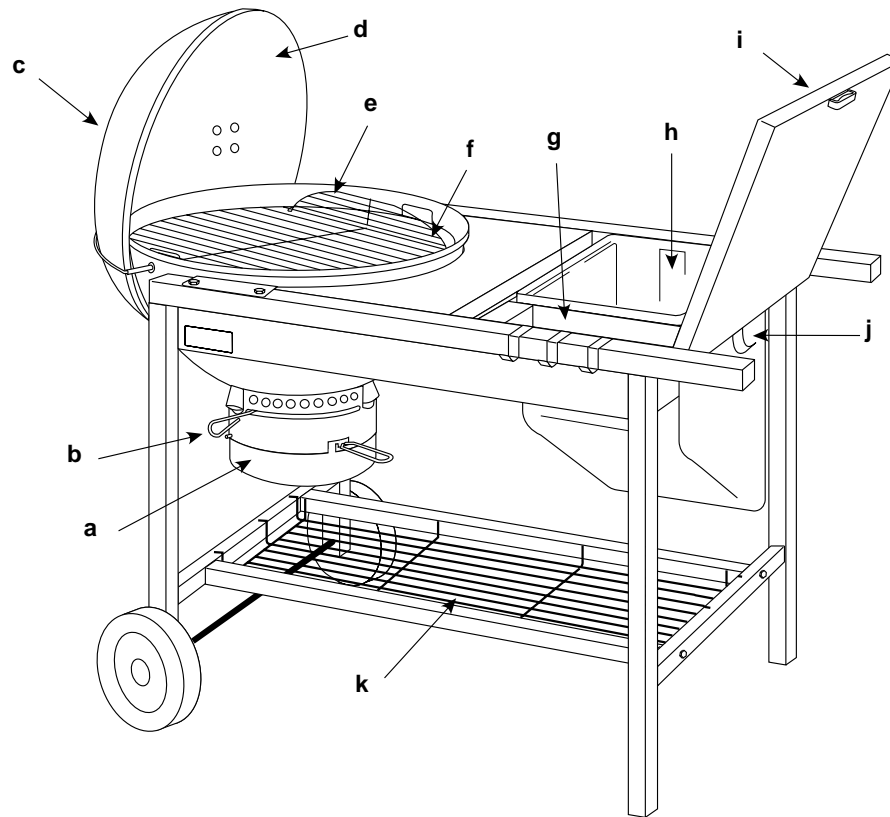

## FEATURES:

- a) High-capacity ash catcher locks in place, eliminating blowing ashes.
- b) Easily sweep out ashes with the One-Touch® Cleaning System.
- c) Patented Dual-Purpose Thermometer monitors the cooking temperature inside the grill, and can also be used as a probe to quickly check the doneness of food.
- d) Tuck-Away™ Lid slides back into the stainless steel lid holder and acts as a windshield when lighting briquets.
- e) Access flaps swing open on the hinged cooking grate for easy addition of briquets or wood chips during cooking.
- f) Char-Basket™ Fuel Holders allow convenient indirect and concentrated direct cooking flexibility with wood or charcoal.
- g) Removable storage tray is a great place to store Weber FireStarters, barbecue mitts, and condiments.
- h) CharBin™ Storage Container holds over 20 lbs. of charcoal within easy reach.
- i) Stainless steel CharBin lid serves as a great work area and covers the CharBin to keep briquets dry.
- j) Stainless steel cooking grate holder.
- k) Convenient bottom rack for storage.

# General Instructions

---

Your Weber Performer Grill is a portable outdoor cooking appliance. You can grill, barbecue, roast and bake with results that are difficult to duplicate with indoor kitchen appliances.

The Performer Grill is portable so you can easily change its location in your yard or on your patio. Portability means you can take your Weber Charcoal Barbecue with you if you move.

- These instructions will give you the minimum requirements for assembling your Performer Grill. Please read the instructions carefully before using your grill. Improper assembly can be dangerous.
- Not for use by children.

## Operating area

**WARNING: Only use this barbecue outdoors in a well-ventilated area. Do not use in a garage, building, breezeway or any other enclosed area.**

- Never use your Performer Grill under an unprotected combustible roof or overhang.
- Do not use combustible materials within 24 inches of the top, bottom, back or sides of the grill.
- The entire barbecue gets hot when in use. Do not leave unattended.
- Keep any electrical supply cord away from any heated surface.
- Keep the cooking area clear of flammable vapors and liquids, such as gasoline, alcohol, etc., and combustible materials.

# ASSEMBLY INSTRUCTIONS

## Tools needed

Phillips screwdriver



7/16 inch or adjustable wrench

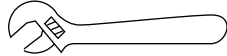
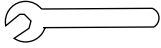

Pliers



## Packages

Your Weber Performer Grill comes in a large box (shipper) which includes a top box, and bottom carton.

There is a hardware pack of small parts and hardware that will be found in the bottom carton.

*Note - The hardware size of nuts, bolts and screws is given. For example "1/4-20 x 1/2 inch bolt" means a bolt 1/4 inch in diameter with 20 threads to the inch, 1/2 inch long. On a small screw, "8-18 x 5/8 inch screw" means a number 8 screw, with 18 threads to the inch, 5/8 inch long.*

While we give much attention to our products, unfortunately an occasional error may occur. If a part is missing, do not go back to the store. Call the Weber Customer Service Center toll free **1-800-446-1071** to receive immediate assistance. Have your owner's manual available for reference.

Check package contents

The following item will be found in the top box.

Bottom rack

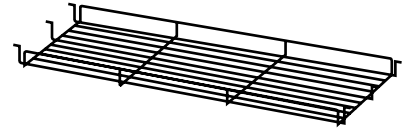

The following items will be found in the large box (shipper).

CharBin Storage Container

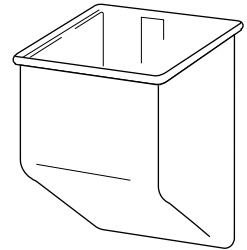

Bowl assembly

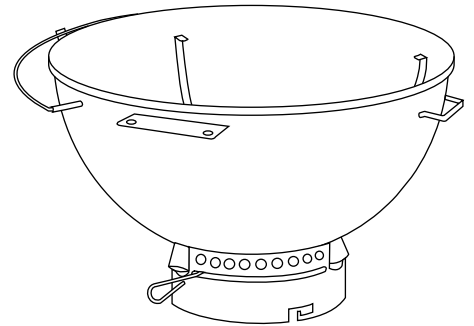

Lid assembly

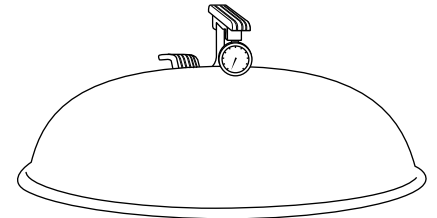

Ash catcher assembly

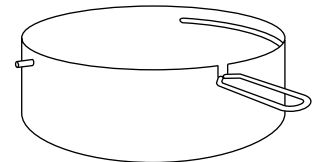

Two Char-Basket Fuel Holders

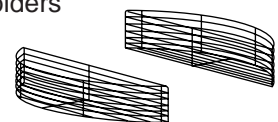



The following items will be found in the bottom carton.

---

Wheel frame

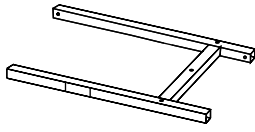

Two bottom connectors

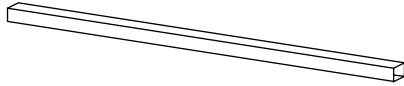

Front panel

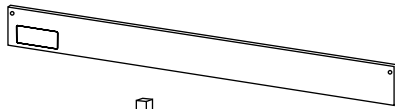

Leg frame

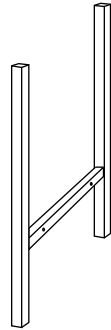

Top frame assembly

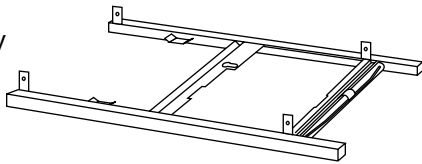

Storage tray

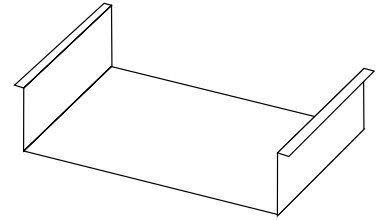

Bowl panel

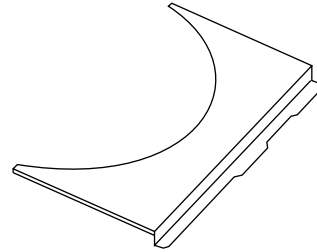

Charcoal grate

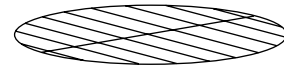

Hinged cooking grate

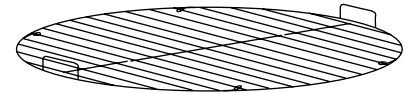

Two wheels

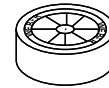

Axle

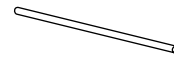

**The following items will be found in the hardware pack.**

---

Sixteen nylon washers  
(actual size)

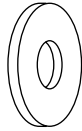

Four aluminum washers  
(actual size)



Eight 1/4-20 x 1 3/4 inch bolts  
(actual size)

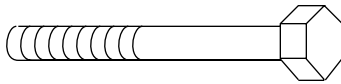

Four 1/4-20 acorn nuts  
(actual size)

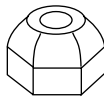

Four 1/4-20 x 1/2 inch bolts  
(actual size)

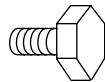

Two #8-18 x 5/8 Phillips head screws  
(actual size)

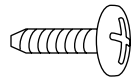

Three tool holders

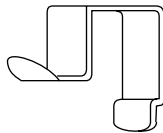

CharBin lid handle

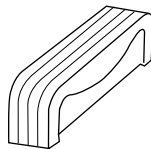

Three hubcaps

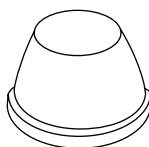

## Step 1

### Assemble wheels

You will need: axle, two wheel hubcaps, two wheels, wheel frame, hammer and a block of wood.

Place one end of the axle on the block of wood (or other protected surface). Tap on one hubcap.

Put one wheel on the axle, WEBER side toward the hubcap. Slide the axle through the frame. Add the other wheel, WEBER side out. Tap on the hubcap. Figure 1.

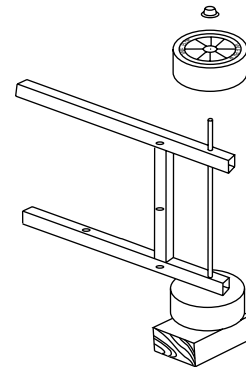

**Figure 1**

## Step 2

### Remove protective packaging

Protective cardboard inserts must be removed from the bowl before assembly. Figure 2. **DO NOT FORCEFULLY REMOVE THE INSERTS.**

- Remove cardboard insert from ash catcher ring. Be careful when removing the cardboard not to bend the ash catcher ring.
- Tear cardboard along the perforations at leg couplings and pull downward.
- Peel off the protective plastic covering from the nameplate on the ash catcher ring.

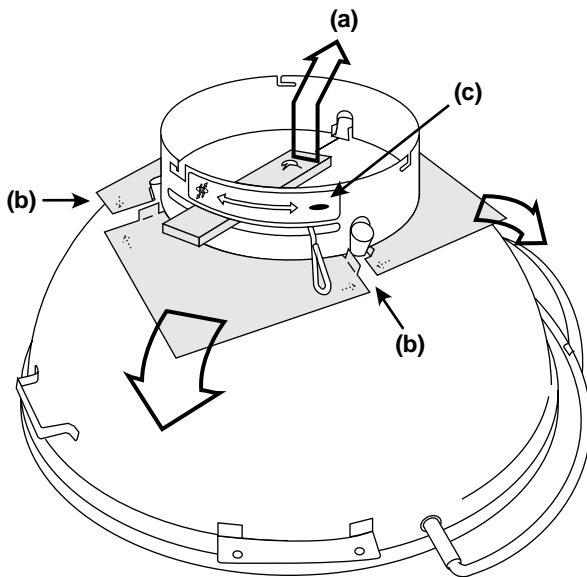

Figure 2

## Step 3

### Assemble the frame

You will need: top frame assembly, wheel frame assembly and leg frame.

*Note - Work on soft surface (grass, or carton inserts) to protect the finish during frame assembly.*

Set the top frame on the ground so the leg tabs point up. Fit the wheel frame assembly onto the leg tabs at the **open end** of the top frame. Figure 3.

Fit the leg frame onto the leg tabs at the other end of the top frame. Figure 3.

The tabs **must** be on the inside of the frame tubes when the joints are closed. Figure 3 (a).

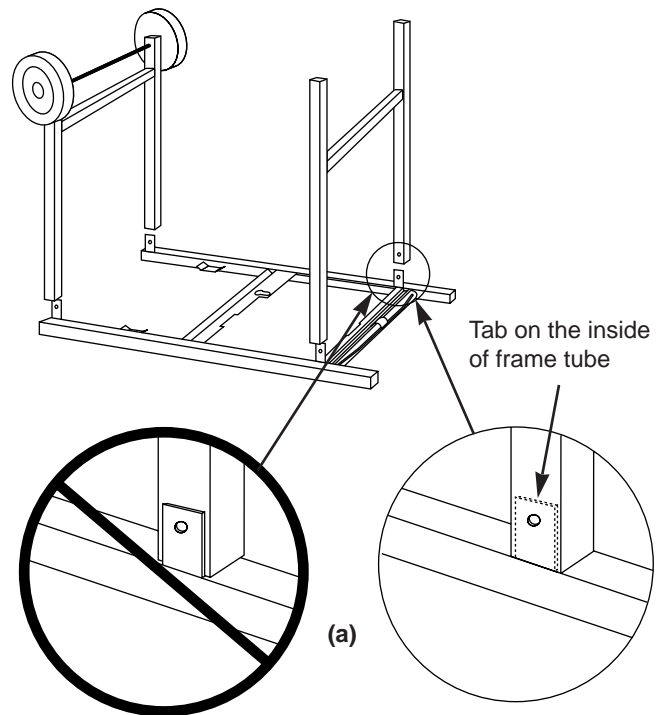

Figure 3

## Step 4

### Continue frame assembly

You will need: frame assembly, front panel, four 1/2 inch bolts, four nylon washers, 7/16 inch wrench.

Place front panel along inside edge of frame assembly with **Weber logo on the side closest to the wheel frame and facing out**. Slip washers on bolts, insert bolts through the front panel and screw into the frame assembly. Figure 4.

Add the remaining bolts and washers and tighten.

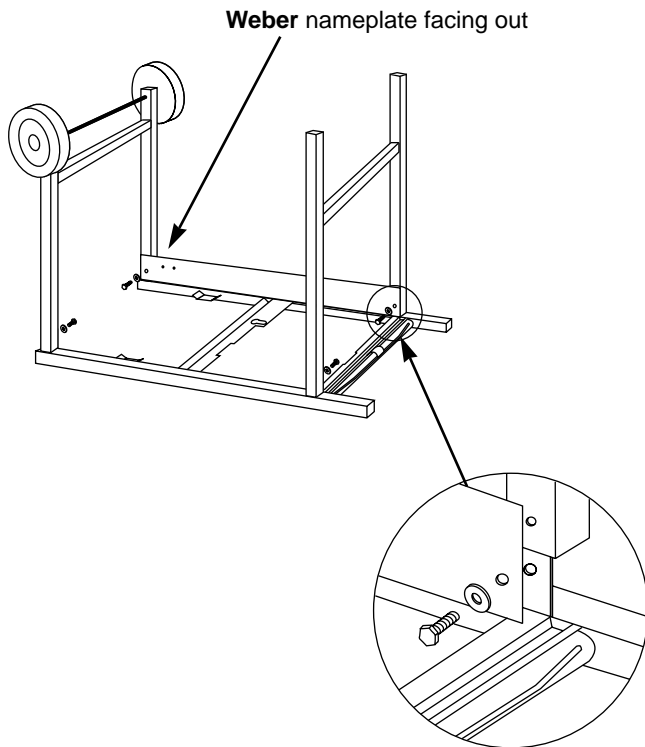

Figure 4

## Step 5

### Complete frame assembly

You will need: two bottom connectors, four 1 3/4 inch bolts, four nylon washers, 7/16 inch wrench.

Turn over partial frame assembly.

Place washer on bolt, insert through frame, and screw into bottom connector. **Do not fully tighten bolts until both bottom connectors are in place**. Place washer on second bolt and insert through frame into opposite end of bottom connector. Figure 5.

Hold the other bottom connector between wheel and leg frame. Add washers to bolts. Insert bolts through frame and screw into bottom connector. Figure 5. Tighten all four bolts.

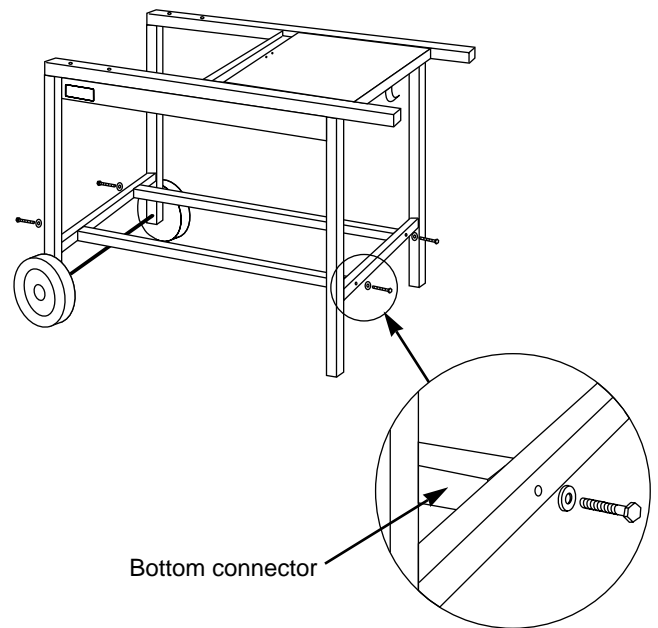

Figure 5

## Step 6

### Install CharBin lid handle

You will need: CharBin lid handle, two 5/8 inch screws and a Phillips screwdriver.

**Remove twist tie and protective plastic covering from CharBin lid.** Lift open lid. Insert screws through holes from inside of lid into handle. Tighten screws. Figure 6.

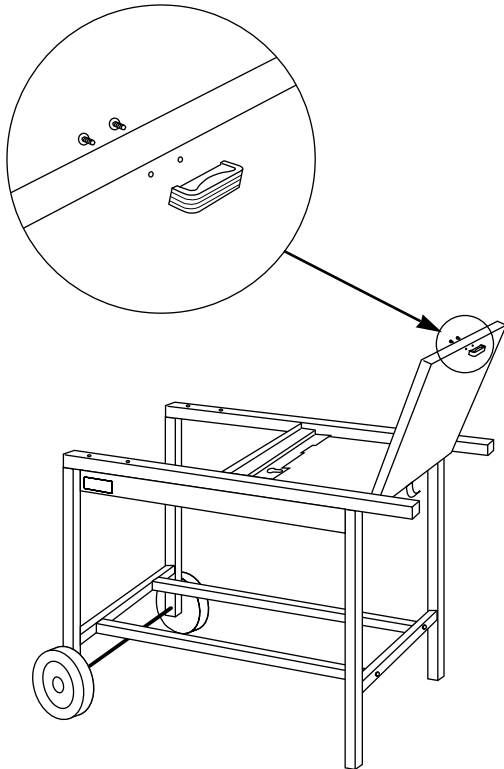

Figure 6

## Step 7

### Install bowl assembly

You will need: bowl assembly, four 1 3/4 inch bolts, eight nylon washers, four aluminum washers, four acorn nuts, 7/16 wrench and pliers.

Set bowl assembly in open end of frame with lid holder to the outside, and align mounting brackets over holes in frame. Figure 7.

Slip a nylon washer on a bolt and insert bolt through bowl mounting bracket and frame. Place a nylon washer then an aluminum washer and acorn nut on end of bolt. Figure 7.

Repeat for the other three bolts. **Do not tighten until all four bolts are correctly in place.**

**CAUTION: Do not overtighten the bolts. Overtightening can fracture the porcelain.**

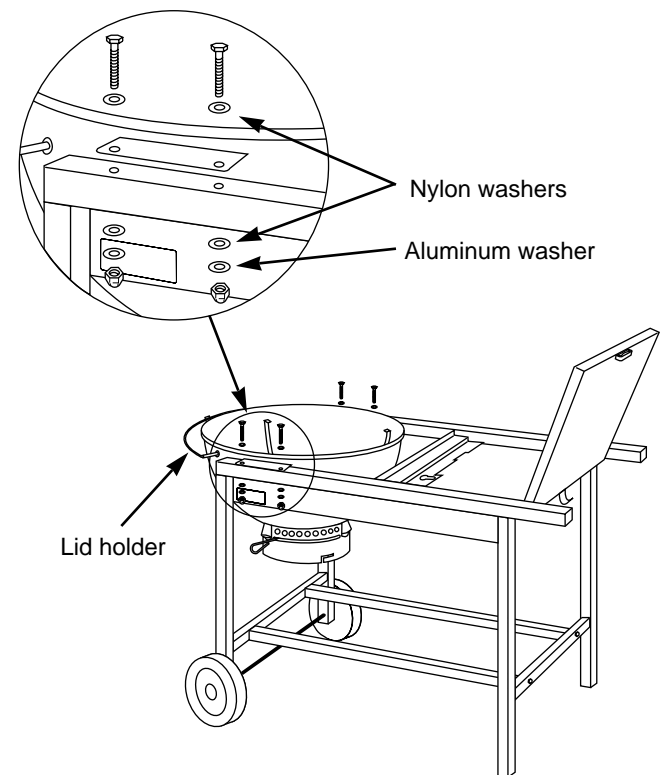

Figure 7

## Step 8

### Add bowl panel, tool holders and CharBin Storage Container

You will need: bowl panel, three tool holders and CharBin Storage Container.

**Remove protective plastic covering from bowl panel.** Slide the ends of bowl panel under bowl mounting brackets so the ends rest on tabs inside frame. Set the panel in place on top of the frame brace. Figure 8.

Hook the tool holders over the frame rail. There is a cut out on the right side of the front panel to accommodate the tool holders. Figure 8.

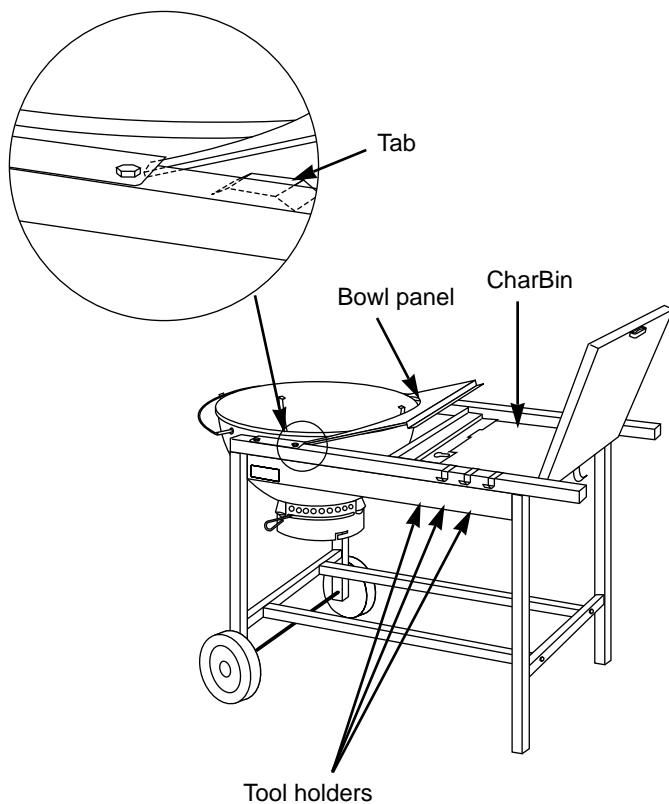

Figure 8

*Note: Before sliding the CharBin into place check that the Cooking grate holder is sitting loosely on the frame brace and is conforming to the frame brace. Figure 9 (a). If it is tight or stuck over the edge of the frame brace, Figure 9 (b), reposition as in Figure 9 (a).*

*If the Cooking grate holder is not correctly positioned, it could allow the CharBin to slide through the frame.*

Slide CharBin down into the top frame with the deep end toward the rear. Figure 9.

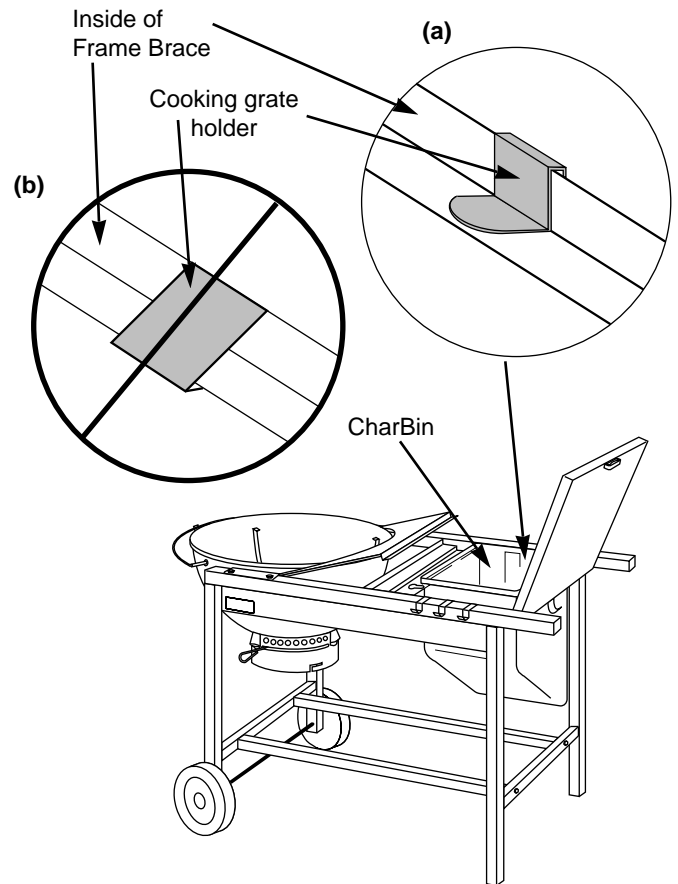

Figure 9

## Step 9

### Install ash catcher, storage tray & bottom rack

You will need: ash catcher, storage tray and bottom rack.

Align handle and prongs of ash catcher with their appropriate slots on the ring. The handle fits into the larger slot. Figure 10 (a).

Lift ash catcher up into slots and rotate to the right. Ash catcher will fit securely into place. Figure 10 (b).

Set storage tray in place between frame braces in front of the CharBin. Figure 10.

Slide bottom rack into position between bottom connectors. Figure 10.

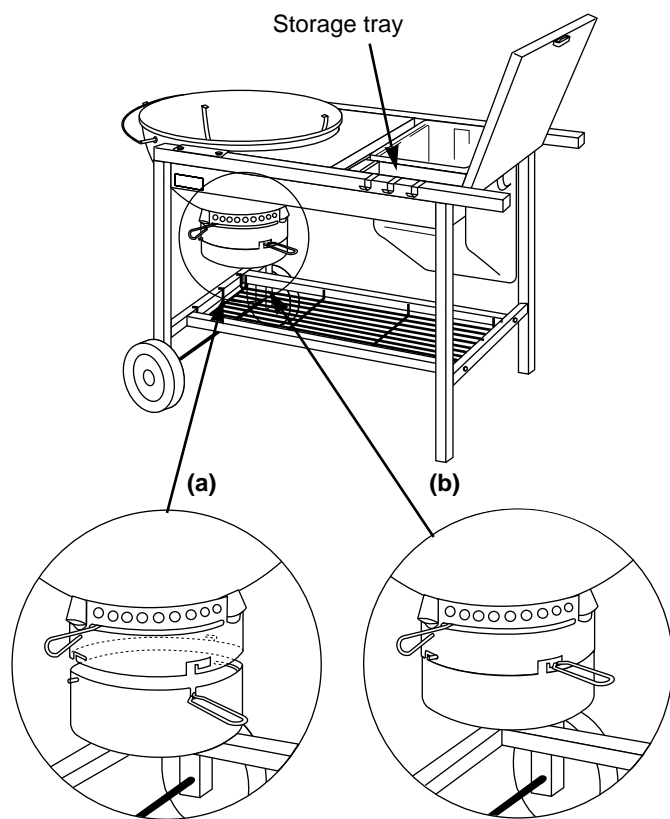

Figure 10

## Step 10

### Add grates, Char-Basket Fuel Holders and lid

You will need: charcoal grate, Char-Baskets, hinged cooking grate and lid.

Place charcoal grate on bottom supports in bowl. Set Char-Baskets on charcoal grate, cooking grate on top supports, and lid on bowl. Figure 11.

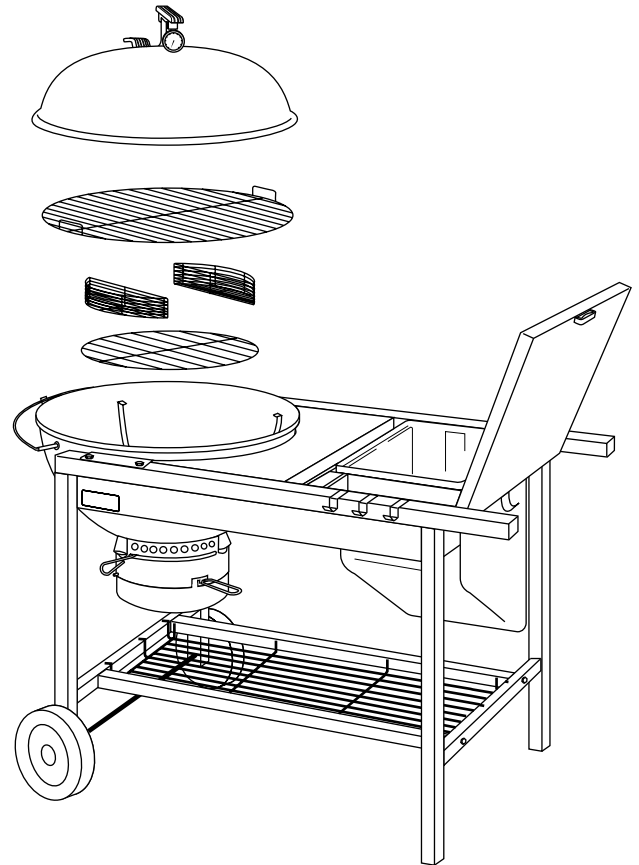

Figure 11

# OPERATING INSTRUCTIONS

## Lighting

**WARNING: Open lid before lighting. Ash catcher must be in place when lighting and any time during use. If using a liquid fire starter, check the ash catcher for any accumulation of starter fluid before lighting charcoal. If fluid is present DO NOT LIGHT. Wipe out any fluid and replace ash catcher before lighting.**

- 1) Open lid.
- 2) Clear bowl of ashes by moving the control rod side to side. Figure 1.

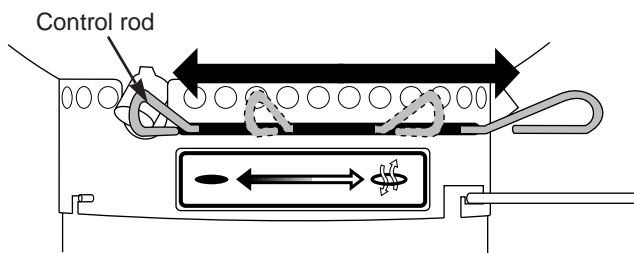

Figure 1

- 3) Open bottom bowl vents. Figure 2.

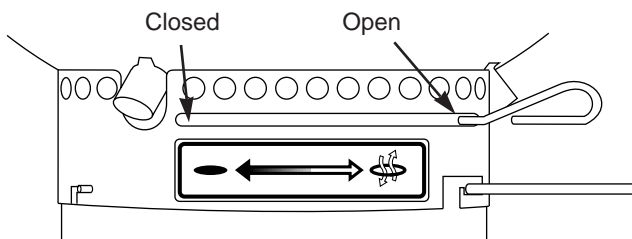

Figure 2

- 4) Position Char-Baskets in center of charcoal grate.
- 5) Light charcoal with Weber FireStarters or another commercially prepared fire starter.

## Periodic Cleaning

**CAUTION: Be sure barbecue is cool before cleaning.**

To remove ashes from the bowl, move control rod side to side so damper blades sweep ashes through the vents. Figure 3.

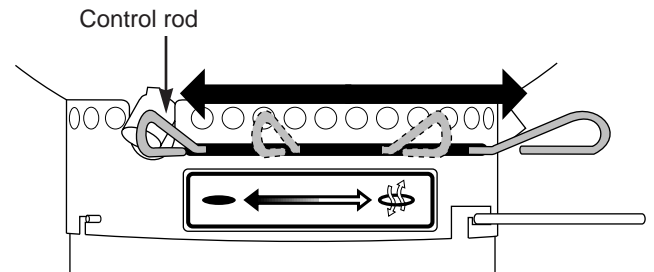

Figure 3

### TO CLEAN KETTLE:

- While lid is warm, wipe the inside with a paper towel to prevent grease buildup.
- For outer surfaces, wash with a warm soapy water solution and rinse with clear water.

For a more thorough cleaning (to be done once a year):

1. Remove ashes.
2. Remove the grates and Char-Baskets.
3. Clean the porcelain finish with with a spray-on type oven cleaner. Spray surfaces heavily with the oven cleaner and leave on long enough to soften accumulated grease.
4. Wipe out with paper towels. Wash with a mild detergent and water. Rinse well with clear water and wipe dry.



# Cooking Methods

## Direct Method

For foods requiring fewer than 30 minutes of cooking time, cook directly over the coals, absorbing the full heat.

1. Place filled Char-Baskets with flat sides together in center of charcoal grate.
2. Ignite charcoal.
3. Coals are ready when they have a light coating of grey ash (approx. 25-30 minutes).
4. Set hinged cooking grate in place.
5. Place meat directly over coals to sear, then move food to the perimeter of the cooking grate.
6. Cover kettle and cook according to directions.

For cooking large quantities of food, charcoal can be piled in a pyramid in the center of the charcoal grate, ignited and spread over the charcoal grate for a larger Direct cooking area.

## Indirect Method

For cooking whole meats such as roasts, turkeys or hams, Char-Baskets are placed on the sides of the kettle to circulate the heat like a convection oven.

When cooking by the Indirect method, Char-Baskets should be positioned as shown in figure 4 with the "flaps" of the hinged cooking grate directly above the baskets. This is for safety reasons so the user can avoid reaching directly over burning coals.

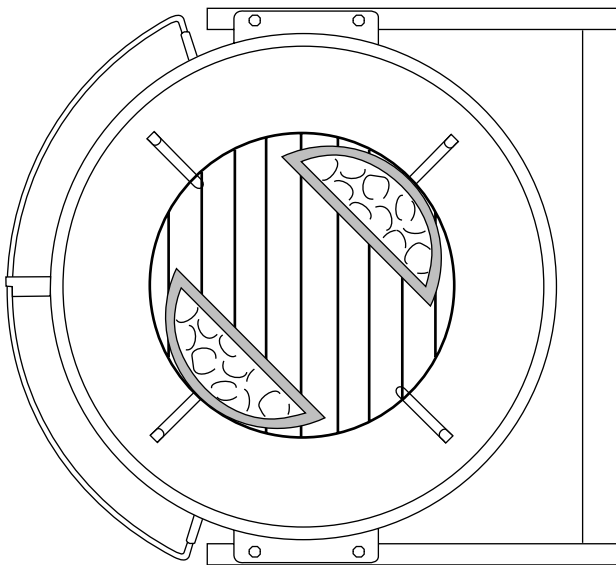

Figure 4

1. Fill each Char-Basket with 25 briquets and place with flat sides together in center of charcoal grate.
2. Ignite charcoal.
3. Move Char-Baskets to opposite sides of the kettle immediately after ignition. Figure 4. Wear barbecue mitts and use long-handled tongs.
4. Place drip pan in the center of the charcoal grate between the Char-Baskets.
5. Set hinged cooking grate in place with the "flaps" directly over the Char-Baskets.
6. Coals are ready when they have a light coating of grey ash (approx. 25-30 minutes).
7. Place food on the cooking grate directly above the drip pan.
8. Cover kettle and cook according to directions.

*Note - For meat that requires more than one hour of cooking time, 8 additional coals must be added at the end of each hour. The "flaps" on the hinged cooking grate can be opened to easily add charcoal to the baskets. Wear barbecue mitts and use long handled tongs to lift "flaps" and add coals.*

It is important in Indirect Cooking to have the coals burning equally well on each side before beginning to cook. Occasionally when the coals are ignited, one side will start faster than the other. If this happens, wear BBQ mitts and use long-handled tongs to move the charcoal from one side to the other so the heat is evenly distributed.

For additional information and cooking times, consult the Weber Owner's Guide.

A few wood chunks or a handful of cooking woodchips may be added to hot coals for a mild smoke flavor in your foods.

**CAUTION: Replace thermometer in lid when not in use. Do not leave thermometer in food while cooking.**

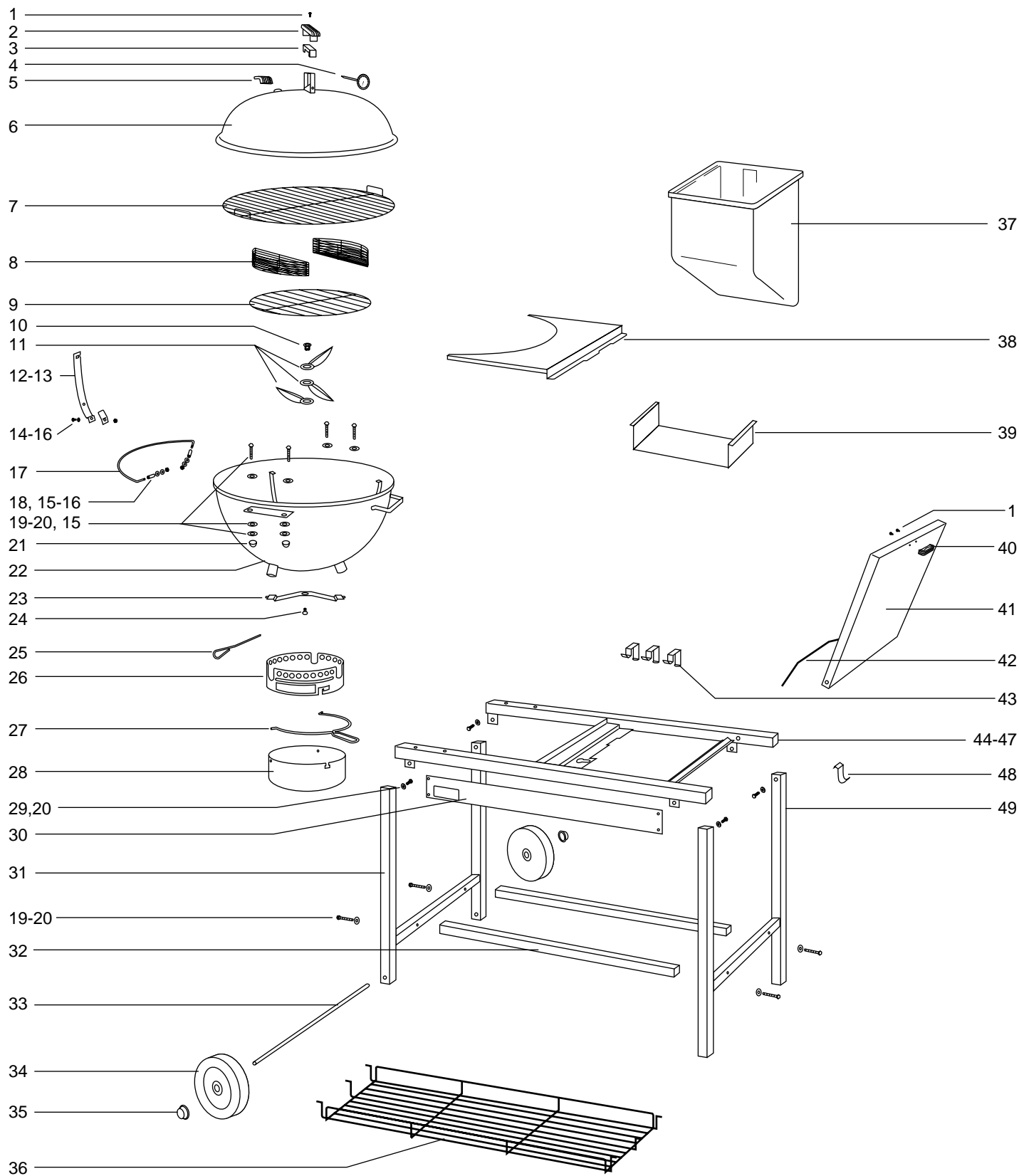

# Parts List

---

All items are single quantities unless otherwise specified.

Parts can be ordered directly from Weber-Stephen Products Company by phone or mail.

*Note - Do not return parts to Weber-Stephen Products Co. without first contacting the Customer Service Center by phone or mail. Returning the part may not be necessary.*

1. #8-18 x 5/8 inch screw (3)
2. Nylon lid handle (top)
3. Nylon lid handle (bottom)
4. Thermometer
5. Nylon damper handle
6. Lid assembly
7. 22 inch hinged cooking grate
8. Char-Basket Fuel Holders (2)
9. Charcoal grate
10. Hex drive
11. Damper blades
12. Lid holder support strap
13. Lid holder lower support
14. 1/4-20 x 5/8 inch truss head screw
15. 1/4 inch aluminum washer (7)
16. 1/4-20 hex keps nut (3)
17. Lid holder wire
18. Bushings (2)
19. 1/4-20 x 1 3/4 inch bolt (8)
20. 1/4 inch nylon washers (16)
21. 1/4-20 acorn nut (4)
22. Bowl
23. Ash catcher support bar
24. Thumbscrew
25. Control rod
26. Ash catcher ring assembly
27. Ash catcher handle
28. Ash catcher
29. 1/4-20 x 1/2 inch bolt (4)
30. Front panel assembly
31. Wheel frame
32. Bottom connector (2)
33. Axle
34. Wheels (2)
35. Wheel hub caps (2)
36. Bottom rack

Contact: Weber-Stephen Products Co.  
Customer Service Center  
250 South Hicks Road  
Palatine, IL 60067-6241  
(800) 446-1071

37. CharBin Storage Container
38. Bowl panel
39. Storage tray
40. CharBin lid handle
41. CharBin lid
42. Hinge rod
43. Tool holders (3)
44. Top frame
45. Tubing plugs (6)
46. Hinge bushings (2)
47. Nylon insert (4)
48. Cooking grate holder
49. Leg frame

## **WARNING:**

**Use only Weber factory authorized parts. The use of any part that is not factory authorized can be dangerous. This will also void your warranty.**

# A FINAL WORD OF THANKS

***T**hank you for choosing a Weber Barbecue.  
Our family here at Weber has worked hard  
to produce the highest quality products  
for your satisfaction.*

*While we give much attention to our products, an  
occasional error may occur. Our knowledgeable  
Customer Service staff is prepared to help you with  
any problems with parts or assembly.*

*Call our toll free number 1-800-446-1071.*

*For quicker service, please have your owner's  
manual available for reference. We also welcome  
any comments or suggestions you might have  
regarding our products.*

*We wish your family the  
best in outdoor cooking enjoyment.*

*Weber-Stephen Products Company  
Customer Service Center  
200 East Daniels Road  
Palatine, Illinois 60067-6266*

