

# MEGA

**POWER IN ACTION**



**MEGA**

**MELCHOR GABILONDO, S.A.**

Polígono Industrial Eitua, 6 / 48240 Bériz (Vizcaya) ESPAÑA / Tel. 94 622 50 90  
Intl.: 34-94 622 50 90 / Telefax: 94 622 52 78 / Intl.: 34-94 622 52 78  
Teléfono Ventas: 94 622 50 30 / Telefax Ventas: 94 682 73 50  
E-MAIL: interior@mega-sa.com / export@mega-sa.com  
Web: www.mega.es

CATALOGUE 2003

## Index Product index

CYLINDERS  
 HYDRAULIC TOOLS  
 PUMPS  
 COMPONENTS  
 MAINTENANCE  
 WORKSHOP EQUIPMENT

### CYLINDERS



Pag. 8-21

Single-acting			With security nut	Flat cylinders	Pulling		Double acting	Hollow piston	
CSRA	CC	CSB	CSF	CSE	CT	CTN	CDRA-CD	CSH	CDH
8-9	10-11	12-13	14-15	16-17	10-11	16-17	18-19	20-21	20-21

### HYDRAULIC TOOLS



Pag. 22-23

Spreader	Load cells		Bolt tensioners	
SH 1	CDM	TDM	THS	THD
22	23	23	22-23	22-23

### PUMPS



Pag. 24-27

Manual		Air-hydraulic	Electric	
Single-acting	Double-acting		Single-acting	Double-acting
24-25	24-25	27	27	

### COMPONENTS



Pag. 28-31

Hoses	Fittings Couplings	Gauges	Adapters	Valves Manifolds
28	28	29	29-31	30

### MAINTENANCE



Pag. 32-35

2-3 Grips		Pullers		Hydraulic bottle jacks	Body repair kits
	Crosshead	Complete sets			
32	32-33	33		34	35

### WORKSHOP EQUIP.



Pag. 36-39

Presses	Cranes	Pipe benders	Lifting tables
36	37	38	39

# MEGA



We have come a long way, but after more than fifty years our course is still market by the desire to achieve quality and innovation so that we can live up to our permanent commitment to improvement.

We maintain our innovative spirit, high standards of quality and strict checks of material and processes. We are making our tools more powerful, safer, more operative and longer lasting.

Thus we place our experience in your hands.

The high reputation of MEGA abroad has enabled us to consolidate a firm position on the markets of all five continents.



Plate laser cutting and welding facilities. CEGAMA

Head office and factory of hydraulic components. BERRIZ

Painting installation, general warehouses and dispatching area. BERRIZ.

# SAFETY INSTRUCTIONS, USE AND MAINTENANCE



Always use a cylinder of a capacity and hydraulic stroke 25% higher than the weight of the load to be lifted.

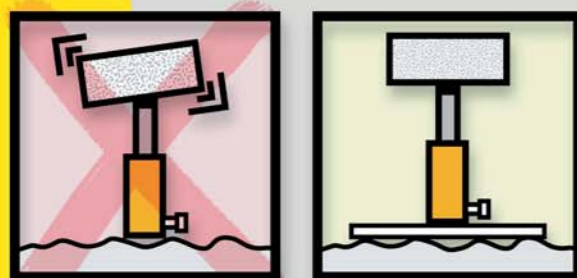

- Position the cylinder on a solid, even and horizontal surface.



- Clean couplers before connecting and make sure the connections are securely tightened.

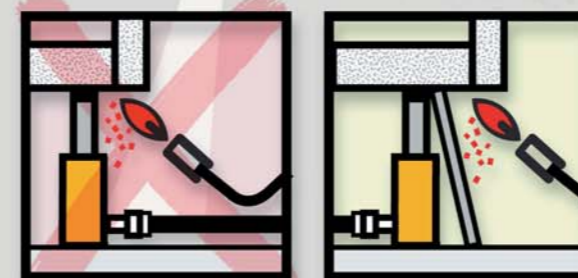

- Avoid extreme heat and temperatures over 65°C.

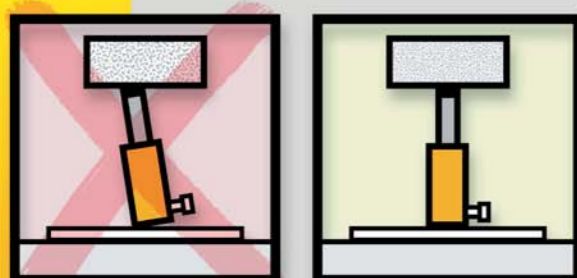

- Never use the cylinder on a slope.



- Never exceed the rated capacity of the cylinder. It is strongly recommended the use of a gauge to check the pressure.

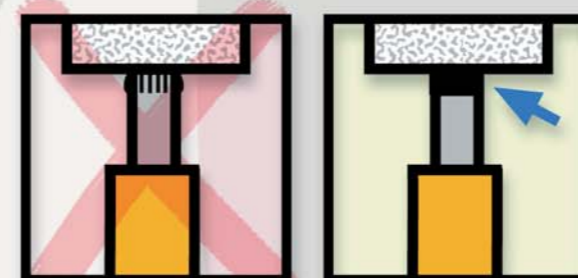

- Never use cylinders without a saddle. The saddle helps centre the load.

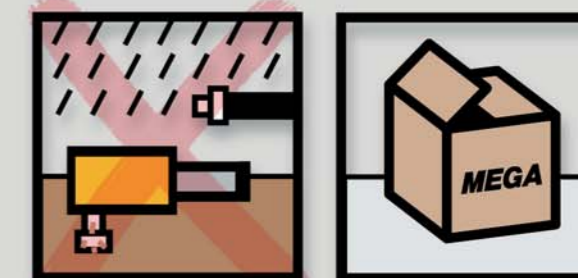

- After use, retract the piston completely, clean the equipment and keep it protected from aggressive environment.



- Keep a safe distance from the load during operation.

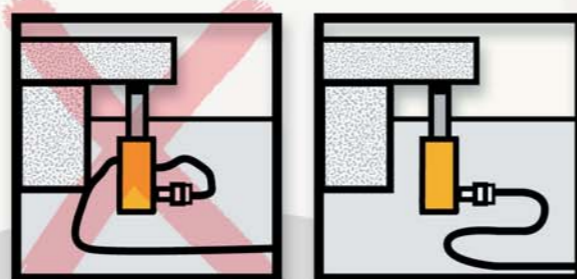

- Prevent hoses from sharp bending and do not drop objects on them.

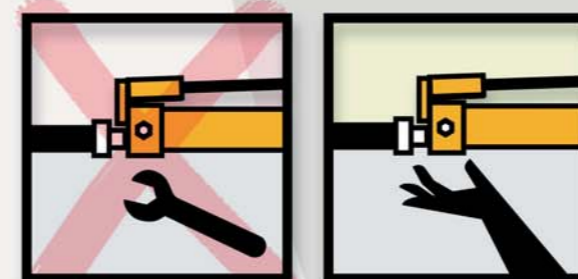

- Never use excessive tightening force that may damage the fittings. Do not use tools.



- Use original MEGA oil.

IMPORTANT. An excess of oil will render the pump inoperative.  
VERY IMPORTANT.- Never use brake fluid.



- Never position any part of your body under the load. Always secure the load with mechanical stands.



- Never disconnect couplers unless the piston is fully retracted. Always use a safety cock to block the cylinder.

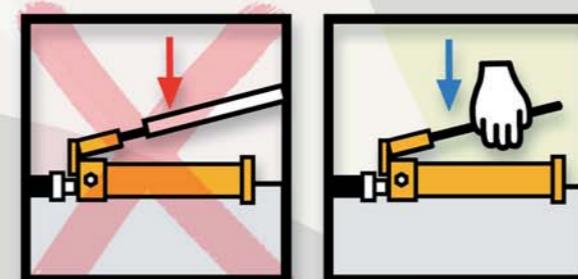

- Never use extensions on hand pumps or jacks. Use only the lever provided.

- Repair kits are available for every item in this catalogue. Always indicate the reference of the item for which the kit is intended.

Basic hydraulic calculations for the correct selection of cylinders and pumps.

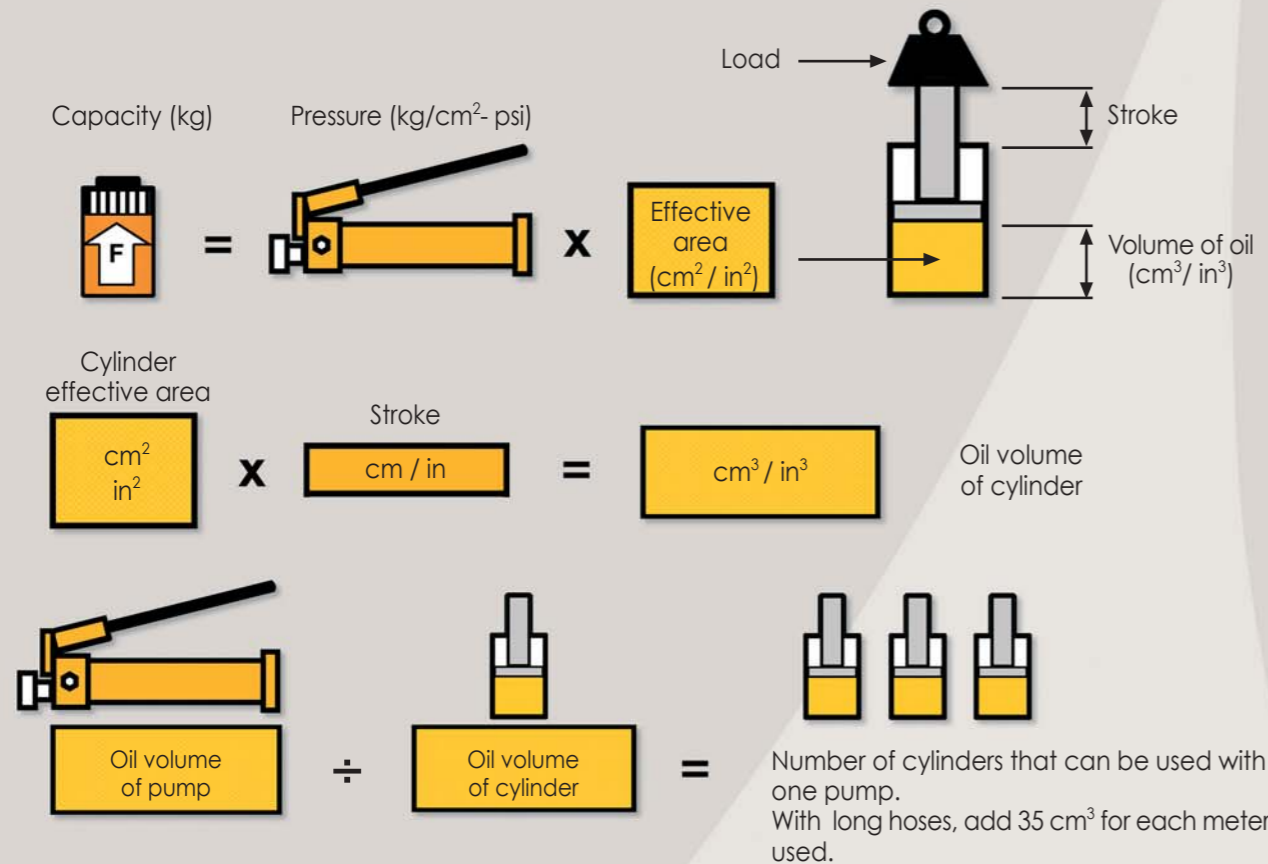

CONVERSION FACTORS

**Pressure:**

1 bar = 14,5 psi  
1 psi = 0,069 bar  
1 bar = 9,8 N/cm<sup>2</sup>  
1 kPa = 0,145 psi

**Volume:**

1 cm<sup>3</sup> = 0,061 in<sup>3</sup>  
1 in<sup>3</sup> = 16,387 cm<sup>3</sup>  
1 litro = 61,02 in<sup>3</sup>  
1 litro = 0,264 gal  
1 USgal = 3785 cm<sup>3</sup> / 3,785 l / 231 in<sup>3</sup>

**Weight:**

1 kg = 2,205 lbs  
1 libra (lb) = 0,4536 kg  
1 tonelada = 1000 kg  
1 tonelada = 2205 lbs métrica

**Area:**

1 mm = 0,039 in  
1 in = 25,4 mm  
1 cm<sup>2</sup> = 0,155 in<sup>2</sup>  
1 in<sup>2</sup> = 6,452 cm<sup>2</sup>

**Others:**

1 hp = 0,746 kW  
1 kW = 1,359 hp  
1 Nm = 0,102 kg/m  
1 Nm = 0,73756 Ft.lbs  
1 Ft.lbs = 1,355818 Nm  
1 kN = 225 lbs

**Temperature:**

Convertir de C° a F°  
F° = (C° x 1,8) + 32  
Convertir de F° a C°  
C° = (F - 32) ÷ 1,8

mm	Inches
1,59	1/16
3,18	1/8
4,76	3/16
6,35	1/4
7,94	5/16
9,53	3/8
11,11	7/16
12,7	1/2
14,29	9/16
15,88	5/8
17,46	11/16
19,05	3/4
20,64	13/16
22,23	7/8
23,81	15/16
25,4	1

Please note that the dimensions of this catalogue are exact in the metric system ( mm ) and approximate in inches.

- 1 Cylinder**  
To raise the load.  
Page 8
- 2 Pump**  
Creates the hydraulic flow.  
Page 24
- 3 Hose**  
Transmits the oil flow.  
Page 28
- 4 A-5507-M**  
Male quick coupler  
Page 28
- 5 A-5507-H**  
Female quick coupler  
Page 28
- 6 Gauge**  
To control pressure.  
Page 29
- 7 Gauge adapter**  
To mount the gauge.  
Page 29
- 8 A-5510**  
Safety valve  
Locks the load on raised cylinder.  
Page 30
- 9 A-5509**  
Shutoff valve  
Shuts the oil flow and locks the load on raised cylinder.  
Page 30
- 10 A-5538**  
Safety relief valve  
Avoids accidental overpressure.  
Page 30
- 11 Manifold**  
To distribute the oil flow.  
Page 31
- 12 A-5511**  
Male connector  
To connect different components.  
Page 31

A basic hydraulic configuration consists of a single-acting cylinder, a pump and a hose. It is really a small machine with the following components: a) Flow generator = Pump. b) Flexible hose to transmit the oil flow from pump to cylinder. c) Hydraulic cylinder, consisting of a chamber with inlet for the oil and a piston to retain the oil and maintain the pressure that raises or lowers as the oil changes within the chamber. The pressure is created by resistance to flow. This resistance is the result of a load. This hydraulic equipment can be used in virtually all types of industry. From a basic pump and cylinder set, you can build many different system configurations by adding components and accessories.

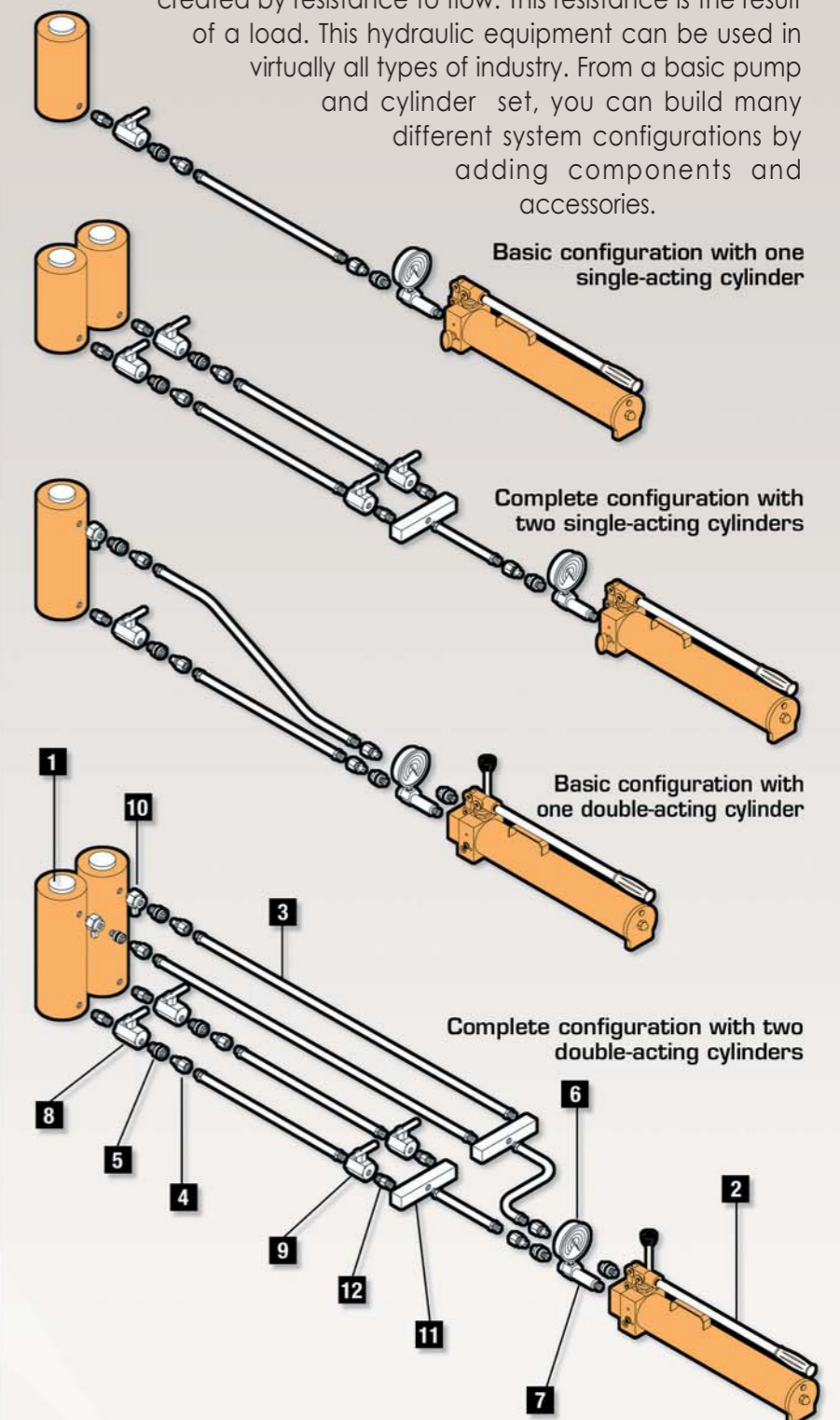

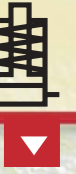

### Mounting applications

Working pressure: 700 kg/cm<sup>2</sup>/10.000 psi.

All pistons have a salt bath nitriding treatment or a hard chrome plating, depending on the model, to resist corrosion and for longer life.

With built-in bronze guide for easier sliding of piston.

These cylinders are fitted with a removable grooved saddle, pressure mounted or screwed in the piston head. They are also equipped with a high flow female quick coupler with dust cap, ref. A-5507-H.

Carry handles on models weighing from 20 kg/44 lbs to 40 kg/88 lbs. Heavier models are fitted with eye hooks for transport.

With mounting holes and threaded areas protected against blows for easy coupling or special tooling applications.



### Single-acting, spring return

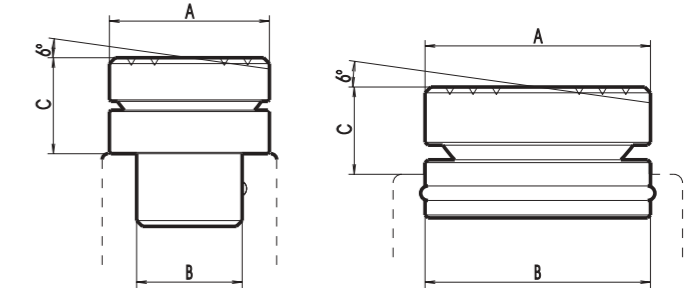
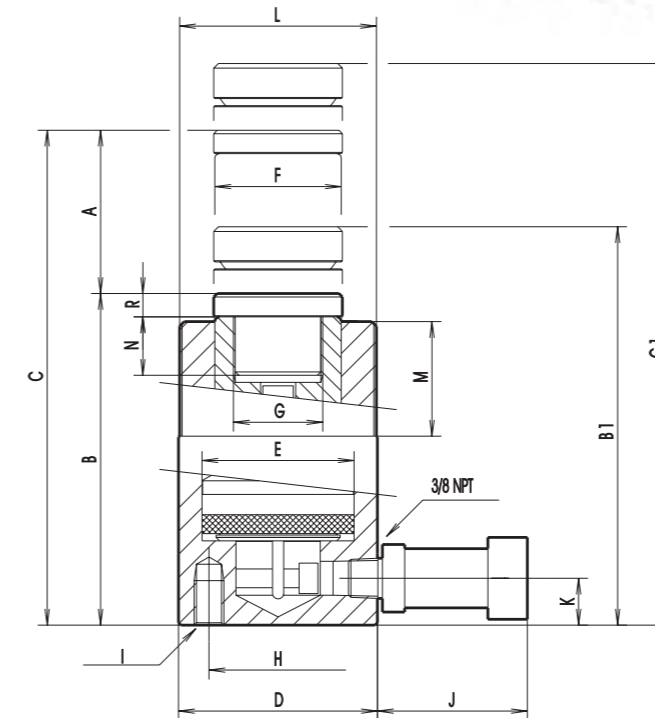

#### ■ Tilting saddle ( optional )

Ref.	Used with	Dimensions mm/in.					
		A		B		C	
BCSRA-5	CSRA-5	26	1 1/32	17,4	11/16	15	19/32
BCSRA-11	CSRA-11, CSRA-16	40	1 9/16	22,1	7/8	20	25/32
BCSRA-23	CSRA-23, CSRA-31	55	2 11/64	36,3	1 7/16	23	29/32
BCSRA-55	CSRA-55	65	2 9/16	56	2 13/64	25	1
BCSRA-93	CSRA-93	80	3 9/32	73,5	2 7/8	31	1 7/32



Cross section view

Rated capacity t in	Ref.	Stroke		Maximum capacity kN	Effective area		B <sub>1</sub> , C <sub>1</sub> with tilting saddle													Oil volume		Weight									
		A			cm <sup>2</sup>	in <sup>2</sup>	Dimensions mm/in.						cm <sup>3</sup>	in <sup>3</sup>	Kg.	lbs.															
		mm.	in.				B	B <sub>1</sub>	C	C <sub>1</sub>	D	E					F	G	H	I	J	K	L	M	N	R					
5	CSRA-5A	25	1	48,5	7,06	1,09	110	4 11/32	125	4 15/16	135	5 5/16	150	5 7/8	40	30	26	3/4-16UNF	25	63/64	1/4-20UNC	70	20	1 1/2-16UN	29	16	6	18	1,1	1	2,2
	CSRA-5B	75	2 15/16				160	6 15/16	175	6 7/8	235	9 1/4	250	9 7/8														54	3,3	1,45	3,2
	CSRA-5C	125	4 15/16				212	8 3/8	227	8 15/16	337	13 1/4	352	13 7/8														90	5,5	1,92	4,2
	CSRA-5D	175	6 7/8				273	10 3/4	288	11 5/16	448	17 5/8	463	18 1/4														126	7,7	2,48	5,6
	CSRA-5E	225	8 7/8				324	12 3/4	339	13 11/32	549	21 5/8	564	22 3/16														162	9,9	2,94	6,5
11	CSRA-11A	25	1	109,1	15,9	2,46	119	4 11/16	139	5 1/2	144	5 11/16	164	6 7/16	60	45	39	1-8UNC	40	1 9/16	5/16-18UNC	70	20	2 1/4-14UNS	27	17	6	40	2,45	2,4	5,3
	CSRA-11B	50	2				144	5 11/16	164	6 7/16	194	7 5/8	214	8 7/16														80	4,9	2,9	6,4
	CSRA-11C	100	3 15/16				194	7 5/8	214	9 7/16	294	11 9/16	314	12 3/8														160	9,75	3,9	8,6
	CSRA-11D	150	5 15/16				244	9 5/8	264	10 3/8	394	15 1/2	414	16 5/16														240	14,65	4,9	10,8
	CSRA-11E	200	7 7/8				298	11 3/4	318	12 1/2	498	19 5/8	518	20 3/8														320	19,5	6	13,2
CSRA-11F	250	9 7/8	348	13 3/4	368	14 1/2	598	23 1/2	618	24 5/16	400	24,4	7	15,4																	
16	CSRA-16A	25	1	163	23,75	3,68	124	4 7/8	144	5 11/16	149	5 7/8	169	6 11/16	70	55	46	1-8UNC	48	1 7/8	3/8-16UNC	70	20	2 3/4-16UN	30	17	10	60	3,65	3,45	7,6
	CSRA-16B	50	2				149	5 7/8	169	6 5/8	199	7 7/8	219	8 5/8														120	7,3	4,15	9,15
	CSRA-16C	100	3 15/16				200	7 7/8	220	8 11/16	300	11 13/16	320	12 5/8														240	14,65	5,55	12,2
	CSRA-16D	150	5 15/16				252	9 15/16	272	10 11/16	402	15 7/8	422	16 5/8														360	22	7	15,4
	CSRA-16E	200	7 7/8				309	12 9/32	329	13	509	20	529	20 7/8														480	29,3	8,6	19
CSRA-16F	250	9 7/8	362	14 1/4	382	16	612	24 1/64	632	24 7/8	600	36,6	10,1	22,3																	
23	CSRA-23A	25	1	227,7	33,08	5,12	140	5 1/2	163	6 7/16	165	6 1/2	188	7 3/8	85	65	54	1 1/2-16UN	59	2 5/16	1/2-13UNC	70	20	3 5/16-12UNS	49	25	10	83	5,05	5,8	12,8
	CSRA-23B	50	2				165	6 1/2	188	7 3/8	215	8 1/2	238	9 3/8														166	10,1	6,8	15
	CSRA-23C	100	3 15/16				216	8 1/2	239	9 7/16	316	12 7/16	339	13 5/16														332	20,2	8,95	19,7
	CSRA-23D	150	5 15/16				267	10 1/2	290	11 7/16	417	16 3/8	440	17 5/16														498	30,4	11,1	24,5
	CSRA-23E	200	7 7/8				324	12 3/4	347	13 11/16	524	20 5/8	547	21 1/2														664	40,5	13	28,7
CSRA-23F	250	9 7/8	375	14 3/4	398	15 11/16	625	14 5/8	648	25 1/2	830	50,6	15,5	34,2																	
31	CSRA-31B	50	2	303,1	44,18	6,84	194	7 5/8	219	8 5/8	244	9 5/8	269	10 5/8	100	75	57,15	1 1/2-16UN	---	---	70	37	3 5/16-12UNS	51	25	10	220	13,4	11	24,2	
	CSRA-31D	150	5 15/16				294	11 9/16	319	12 9/16	444	17 1/2	469	18 7/16													660	40,3	16,7	36,8	
	CSRA-31E	200	7 7/8				344	13 9/16	369	14 1/2	544	21 3/8	569	22 3/8													880	53,7	19,5	43	
55	CSRA-55B	50	2	539	78,54	12,17	169	6 5/8	194	7 5/8	219	8 5/8	244	9 5/8	130	100	80	---	95	3 3/4	1/2-13UNC	70	20	5-12UN	45	---	2	392	23,9	15,9	36
	CSRA-55C	100	3 15/16				219	8 5/8	244	9 5/8	319	12 9/16	344	13 9/16														784	47,8	20,6	45,4
	CSRA-55D	150	5 15/16				269	10 5/8	294	11 9/16	419	16 1/2	444	17 1/2														1176	71,8	25,3	55,8
93	CSRA-93B	50	2	910,9	132,73	20,57	190	7 1/2	221	8 11/16	240	9 7/16	271	10 11/16	175	130	105	---	---	70	47	6 7/8-12UN	50	---	2	664	40,5	32,3	71,2		
	CSRA-93D	150	3 15/16				290	11 7/16	321	12 5/8	440	17 5/16	471	18 9/16												1992	121,6	49,3	108,7		

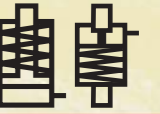

## Coupling applications

### CC: PUSHING CT: PULLING

Working pressure: 700 kg/cm<sup>2</sup>/10.000 psi.

All pistons have an induction hardening treatment or a salt bath nitriding process depending on the model.

Each ram is equipped with a female quick coupler with air dust cap, ref. A-5507-H.

With mounting holes and protected threaded areas against possible blows for easy coupling or special tooling applications.

Unlike the pushing cylinders, the pulling rams retract toward the base to apply pressure.

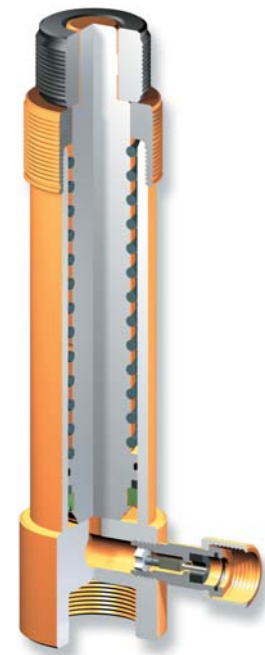
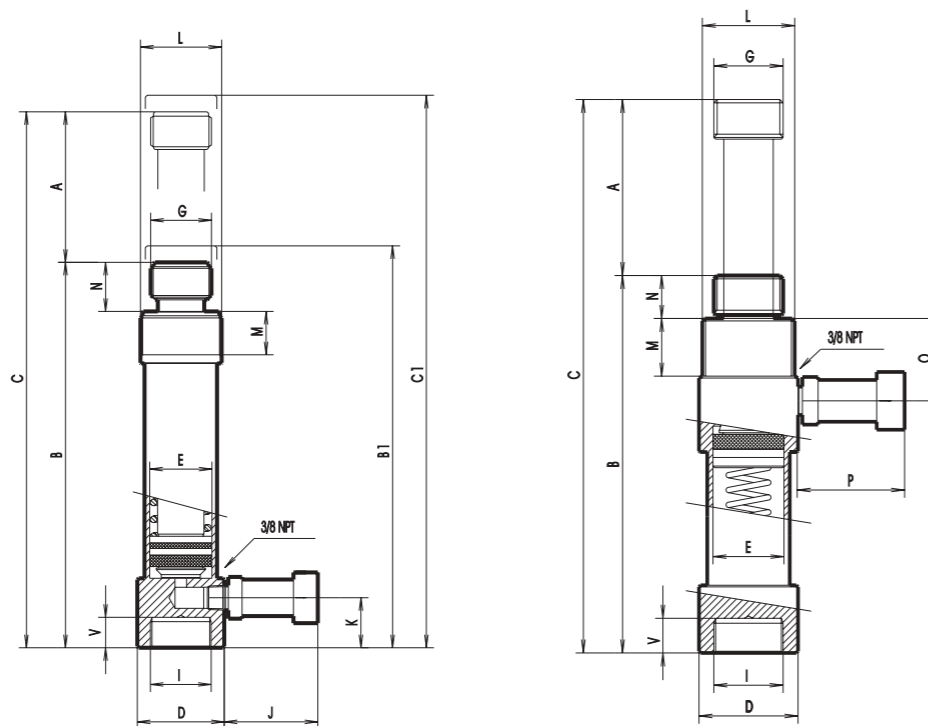

Cross section view ( CC )

## Single-acting, spring return

These pushing and pulling cylinders can be original components of the Maintenance Kits described on page 35.

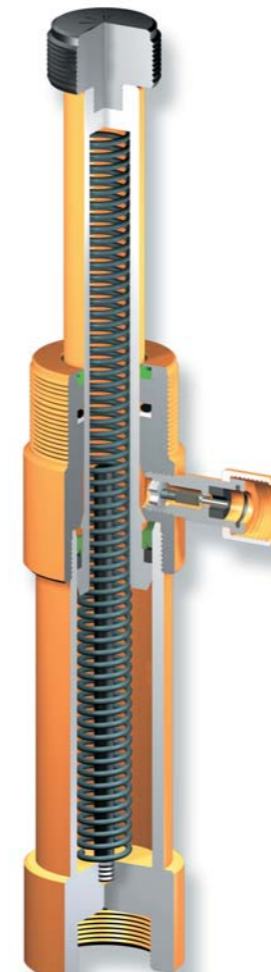

Cross section view ( CT )

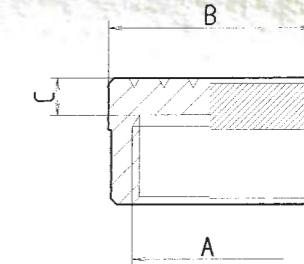

### ■ Grooved saddle ( optional )

Ref.	Used with	Dimensions mm/in.		
		A	B	C
A-5142	CC-5 SERIES	M26 x 2	32 1 17/64	8 5/16
A-5042	CC-10 SERIES	M42 x 2,5	54 2 7/8	10 25/64
A-5242	CC-20 SERIES	M60 x 2,5	74 2 29/32	12 15/32

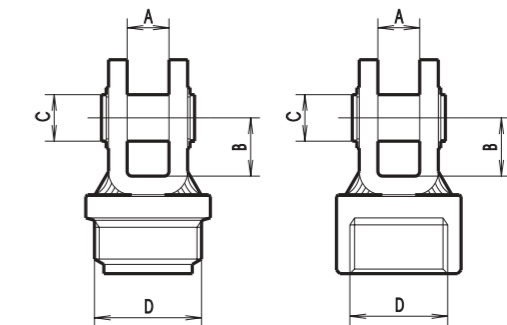

### ■ Attachments for pulling and pushing pistons ( optional )

Ref.	Used with	Dimensions mm/in.			
		A	B	C	D
A-5188	CC-5, CT-2,5 SERIES	18 23/32	25 1	20 25/32	M26 x 2
A-5189		18 23/32	25 1	20 25/32	M42 x 2,5
A-5088	CC-10, CT-5 SERIES	18 23/32	25 1	20 25/32	M42 x 2,5
A-5089		18 23/32	25 1	20 25/32	M60 x 2,5
A-5288	CC-20, CT-10 SERIES	18 23/32	30 1 3/16	20 25/32	M60 x 2,5
A-5289		18 23/32	30 1 3/16	20 25/32	M60 x 2,5

Rated capacity tn	Ref.	Stroke mm. A in.	Maximum capacity kN	Effective area cm <sup>2</sup> in <sup>2</sup>	B <sub>1</sub> , C <sub>1</sub> with tilting saddle															Oil volume		Weight	
					Dimensions mm/in.															cm <sup>3</sup>	in <sup>3</sup>	Kg.	lbs.
					B	B <sub>1</sub>	C	C <sub>1</sub>	D	E	G	I	J	K	L	M	N	O	P				
5	CC-5A	50 2	55	8,04 1,24	177 6 15/16	184 7 5/16	227 8 15/16	235 9 1/4	45 1 49/64	32 1 1/4	M26 x 2	M26 x 2	70 2 3/4	33 1 5/16	M38 x 1,5	22 7/8	20 13/16	---	---	18 11/16	40 2,44	1,35 3	
	CC-5B	115 4 1/2	55	8,04 1,24	284 11 3/16	292 11 1/2	399 15 11/16	407 16	60 2 11/32	43 1 11/16	M42 x 2,5	M42 x 2,5	70 2 3/4	30 1 3/16	M56 x 2	36 1 7/16	26 1 1/32	---	---	21 13/16	92 5,61	2,2 4,9	
10	CC-10A	50 2	99,6	14,52 2,25	191 7 1/2	201 7 15/16	241 9 1/2	251 9 7/8	60 2 11/32	43 1 11/16	M42 x 2,5	M42 x 2,5	70 2 3/4	38 1 1/2	M56 x 2	36 1 7/16	26 1 1/32	---	---	21 13/16	73 4,45	2,4 5,3	
	CC-10B	135 5 5/16	99,6	14,52 2,25	332 13 1/16	342 13 7/16	467 18 3/8	477 18 3/4	79 3 1/8	60 2 11/32	M60 x 2,5	M60 x 2,5	70 2 3/4	35 1 3/8	M84 x 2	48 1 7/8	30 1 3/16	---	---	23 7/8	196 11,96	4,35 9,6	
20	CC-20A	50 2	194	28,27 4,38	216 8 1/2	228 9	266 10 1/2	278 10 15/16	79 3 1/8	60 2 11/32	M60 x 2,5	M60 x 2,5	70 2 3/4	44 1 3/4	M84 x 2	48 1 7/8	30 1 3/16	---	---	23 7/8	141 8,6	5,5 12,1	
	CC-20B	130 5 1/8	194	28,27 4,38	364 14 5/16	376 14 13/16	494 19 7/16	506 19 15/16	79 3 1/8	60 2 11/32	M60 x 2,5	M60 x 2,5	70 2 3/4	40 1 9/16	M84 x 2	48 1 7/8	30 1 3/16	---	---	23 7/8	368 22,46	10 2,2	
2,5	CT-2,5	127 5	29,1	4,24 0,65	270 10 5/8	---	397 15 5/8	---	45 1 49/64	32 1 1/4	M26 x 2	M26 x 2	---	---	M38 x 1,5	24 15/16	21 1 13/16	70 2 3/4	70 2 3/4	16 5/8	54 3,29	2,25 5	
5	CT-5	138 5 7/16	51,1	7,45 1,15	311 12 1/4	---	449 17 11/16	---	60 2 11/32	43 1 11/16	M42 x 2,5	M42 x 2,5	---	---	M56 x 2	35 1 3/8	24 15/16	70 2 3/4	70 2 3/4	21 13/16	103 6,28	3,9 8,6	
10	CT-10	138 5 7/16	99	14,41 2,23	318 12 1/2	---	456 17 15/16	---	79 3 1/8	60 2 3/8	M60 x 2,5	M60 x 2,5	---	---	M84 x 2	35 1 3/8	27 1 1/16	70 2 3/4	70 2 3/4	21 13/16	199 12,14	8 17,6	

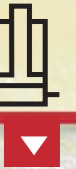

## General application

Working pressure: 700 kg/cm<sup>2</sup>/10.000 psi.

All pistons have a salt bath nitriding treatment or a hard chrome plating, depending on the model, to resist corrosion and for longer life.

With built-in bronze guide for easier sliding of piston.

These cylinders are fitted with a removable grooved saddle, pressure mounted or screwed in the piston head. They are also equipped with a female quick coupler with dust cap, ref. A-5507-H.

Carry handles on models weighing from 20 kg/44 lbs to 40 kg/88 lbs. Heavier models are fitted with eye hooks for transport.

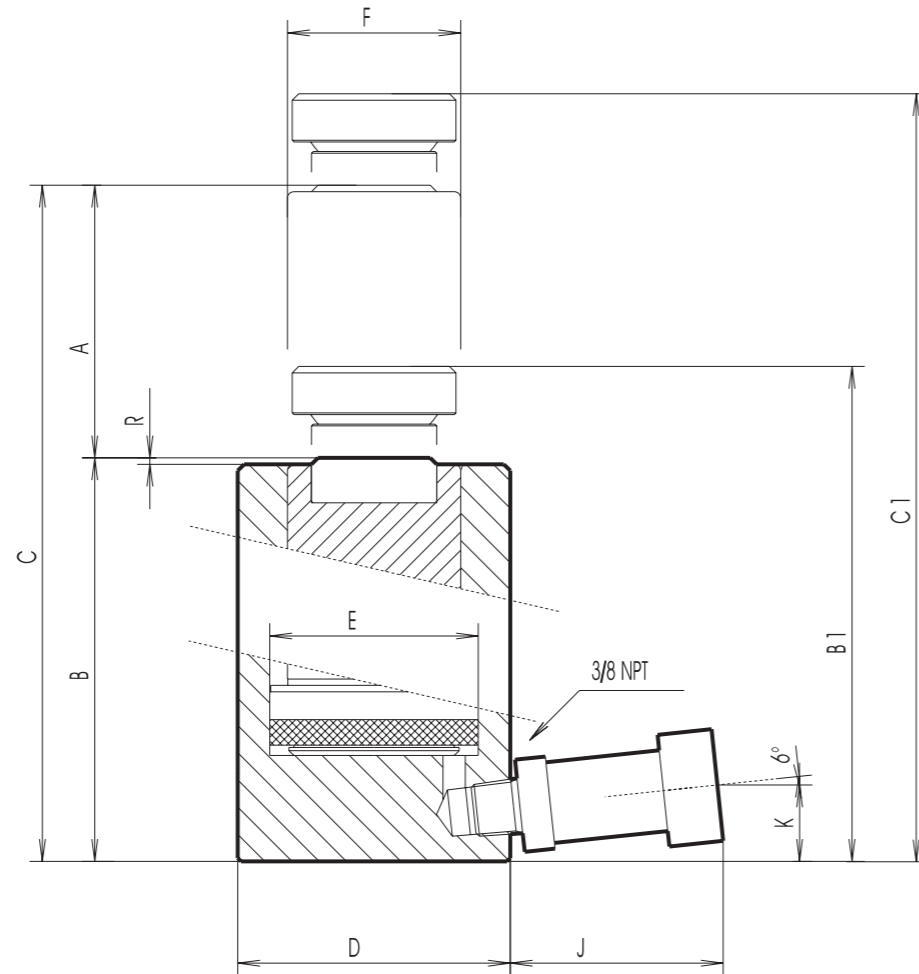

## Single-acting, load return

Ideal for a wide range of applications in civil engineering, heavy fabrication, construction, maintenance and lifting of very heavy loads.



### ■ Tilting saddle ( optional )

Ref.	Used with	Dimensions mm/in.					
		A		B		C	
BCSB-11	CSB-11	40	1 9/16	27	1 1/16	14	35/64
BCSB-23	CSB-23	55	2 11/64	39	1 17/32	16	5/8
BCSB-31	CSB-31	55	2 11/64	39	1 17/32	22	55/64
BCSRA-55	CSB-55	65	2 9/16	56	2 13/64	25	1
BCSRA-93	CSB-93	80	3 6/32	73,5	2 7/8	31	1 7/32
BCSB-200	CSB-200	138	5 7/16	124	4 7/8	50	2
BCSB-300	CSB-300	155	6 1/64	130	5 1/8	65	2 9/16
BCSB-400	CSB-400	185	7 9/32	160	6 5/16	78	3 5/64
BCSB-500	CSB-500	205	8 1/16	180	7 3/32	88	3 15/32

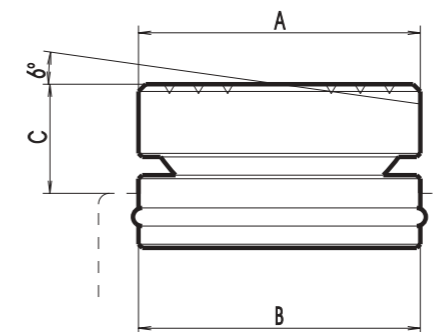

Cross section view

Rated capacity tn	Ref.	Stroke		Maximum capacity kN	Effective area		B <sub>1</sub> , C <sub>1</sub> with tilting saddle														Oil volume		Weight							
		mm.	in.		cm <sup>2</sup>	in <sup>2</sup>	Dimensions mm/in.														cm <sup>3</sup>	in <sup>3</sup>	Kg.	lbs.						
							B	B <sub>1</sub>	C	C <sub>1</sub>	D	E	F	J	K	R														
11	CSB-11A	38	1 1/2	109,1	15,9	2,46	109	4 5/16	123	4 7/8	147	5 13/16	161	6 5/16	60	2 11/32	45	1 49/64	39	1 17/32	70	2 3/4	23	15/16	2	5/64	60	3,66	2,2	4,8
23	CSB-23B	50	2	227,7	33,18	5,14	124	4 7/8	140	5 1/2	174	6 7/8	190	7 1/2	85	3 3/8	65	2 9/16	54	2 1/8	70	2 3/4	23	15/16	2	5/64	166	10,1	5	11
31	CSB-31B	50	2	303,1	44,18	6,84	125	4 15/16	147	5 13/16	175	6 7/8	197	7 3/4	100	3 15/16	75	2 61/64	57,15	2 1/4	70	2 3/4	23	15/16	2	5/64	220	13,4	6,9	15,2
55	CSB-55B	50	2	539	78,54	12,17	138	5 7/16	163	6 7/16	188	7 7/16	213	8 3/8	130	5 1/8	100	3 15/16	80	3 6/32	70	2 3/4	23	15/16	2	5/64	392	23,9	12,9	28,4
93	CSB-93B	50	2	910,9	132,73	20,57	130	5 1/8	160	6 5/16	180	7 1/16	210	8 1/4	163	6 7/16	130	5 1/8	105	4 9/64	70	2 3/4	23	15/16	2	5/64	664	40,5	20	44
200	CSB-200B	50	2	1945,8	283,52	43,95	219	8 5/8	269	10 5/8	269	10 5/8	319	12 9/16	242	9 9/16	190	7 1/2	150	5 15/16	70	2 3/4	62	2 7/16	5	3/16	1417	86,5	70,8	156
	CSB-200D	150	5 15/16				319	12 9/16	369	14 1/2	469	18 7/16	519	20 7/16																
300	CSB-300D	150	5 15/16	2976,5	433,73	67,24	371	14 9/16	436	17 3/16	521	20 1/2	586	23 1/16	302	11 7/8	235	9 1/4	170	6 11/16	70	2 3/4	78	3 1/16	5	3/16	6506	397,2	183	403
	CSB-300F	250	9 7/8				481	18 15/16	546	21 1/2	731	28 13/16	796	31 5/16																
400	CSB-400D	150	5 15/16	4017,1	585,35	90,75	381	15	459	18 1/16	531	20 7/8	609	24	349	13 3/4	270	10 5/8	210	8 1/4	70	2 3/4	88	3 7/16	5	3/16	8780	536	259	570
	CSB-400F	250	9 7/8				491	19 5/16	569	22 3/8	741	29 3/16	819	32 1/4																
500	CSB-500D	150	5 15/16	5014	730,6	113,27	400	15 3/4	488	19 3/16	550	21 5/8	638	25 1/8	392	15 7/16	305	12	240	9 7/16	70	2 3/4	91	3 9/16	5	3/16	10960	669	343	755
	CSB-500F	250	9 7/8				510	20 1/16	598	23 9/16	760	29 15/16	848	33 3/8																



# HYDRAULIC CYLINDERS



CSF Series

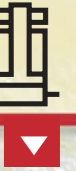

## With security lock nut

Working pressure: 700 kg/cm<sup>2</sup>/10.000 psi.

All pistons have a salt bath nitriding treatment to resist corrosion.

With built-in bronze guide for easier sliding of piston.

These cylinders are fitted with a removable grooved saddle, pressure mounted or screwed in the piston head. They are also equipped with a high flow female quick coupler with dust cap, ref. A-5507-H.

Carry handles on models weighing from 20 kg/44 lbs to 40 kg/88 lbs. Heavier models are fitted with eye hooks for transport.

The mechanical lock of load is effected by a safety lock nut at the piston extension desired.

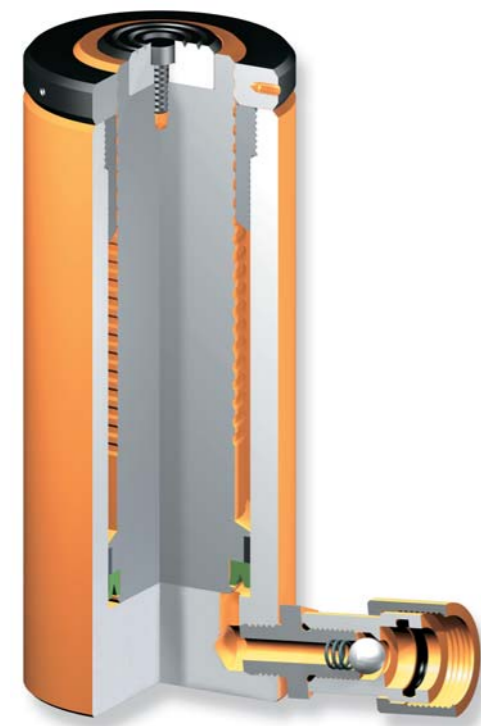
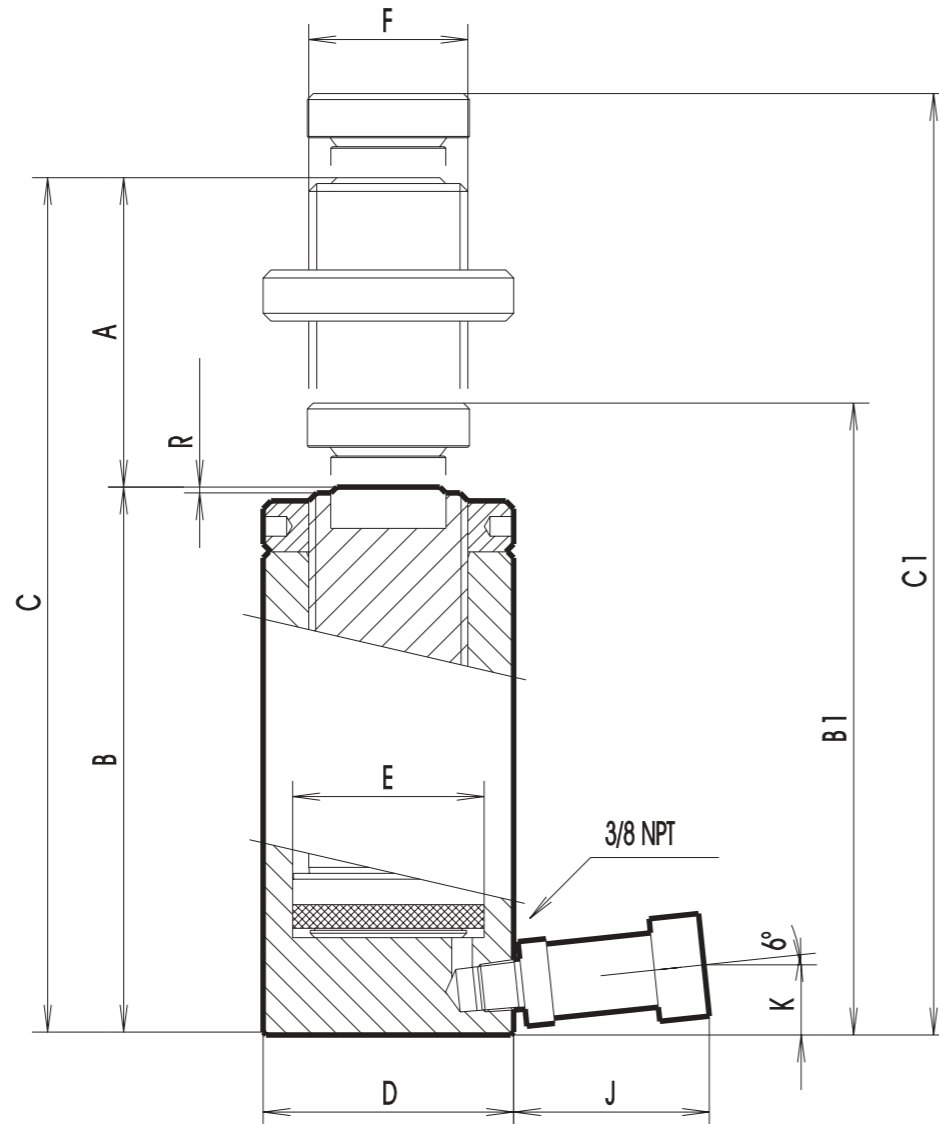

Cross section view

## Single-acting, load return

Particularly recommended for foundations in construction, bridge building and maintenance of heavy machinery in public works or steel industry, specially when load must be kept on hold for long periods.

The safety lock nut allows disconnection of the pump and ensure total safety conditions when operating under the load.



## With tilting saddle ( optional )

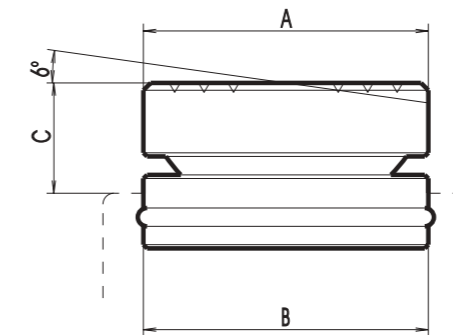

Ref.	Used with	Dimensions mm/in.					
		A		B		C	
BCSB-31	CSF-31 SERIES	55	2 11/64	39	1 17/32	22	55/64
BCSRA-55	CSF-55 SERIES	65	2 9/16	56	2 13/64	25	1
BCSRA-93	CSF-93 SERIES	80	3 9/32	73,5	2 7/8	31	1 7/32
BCSB-200	CSF-200 SERIES	138	5 7/16	124	4 7/8	50	2
BCSB-300	CSF-300 SERIES	155	6 1/64	130	5 1/8	65	2 9/16
BCSB-400	CSF-400 SERIES	185	7 9/32	160	6 5/16	78	3 3/64
BCSB-500	CSF-500 SERIES	205	8 1/16	180	7 3/32	88	3 15/32

Nominal capacity tn	Ref.	Stroke		Maximum capacity kN	Effective area		B <sub>1</sub> , C <sub>1</sub> with tilting saddle														Oil volume		Weight						
		mm.	in.		cm <sup>2</sup>	in <sup>2</sup>	Dimensions mm/in.														cm <sup>3</sup>	in <sup>3</sup>	Kg.	lbs.					
		A			B	B <sub>1</sub>	C	C <sub>1</sub>	D	E	F	J	K	R															
31	CSF-31D	150	5 15/16	303,1	44,18	6,84	272	10 11/16	294	11 9/16	422	16 5/8	444	17 1/2	100	3 15/16	75	2 61/64	TR 2 1/4 x 5	70	2 3/4	23	15/16	2	5/64	660	40,3	14,5	32
55	CSF-55D	150	5 15/16	539	78,54	12,17	293	11 1/2	318	12 1/2	443	17 7/16	468	18 7/16	130	5 1/8	100	3 15/16	TR 80 x 5	70	2 3/4	23	15/16	2	5/64	1176	71,8	27,2	60
93	CSF-93D	150	5 15/16	910,9	132,73	20,57	326	12 13/16	356	14	476	18 3/4	506	19 15/16	175	6 7/8	130	5 1/8	TR 105 x 5	70	2 3/4	47	1 27/32	2	5/64	1992	121,6	56,4	125
200	CSF-200D	150	5 15/16	1945,8	283,52	43,95	374	14 3/4	424	16 11/16	524	20 5/8	574	22 5/8	242	9 9/16	190	7 1/2	TR 160 x 5	70	2 3/4	62	2 7/16	5	3/16	4252	259,6	125	275
300	CSF-300D	150	5 15/16	2976,5	433,73	67,24	435	17 1/8	500	19 11/16	585	23	650	25 5/8	302	11 7/8	235	9 1/4	TR 180 x 5	70	2 3/4	78	3 1/16	5	3/16	6506	397,2	222	490
	CSF-300F	250	9 7/8				545	21 7/16	610	24	795	31 5/16	860	33 7/8												10843	662	269	593
400	CSF-400D	150	5 15/16	4017,1	585,35	90,75	450	17 11/16	528	20 3/4	600	23 5/8	678	26 11/16	349	13 3/4	270	10 5/8	TR 220 x 5	70	2 3/4	88	3 7/16	5	3/16	8780	536	315	695
	CSF-400F	250	9 7/8				560	22	638	25 1/8	810	31 7/8	888	35												14633	894	383	845
500	CSF-500D	150	5 15/16	5014	730,6	113,27	475	18 11/16	563	22 3/16	625	24 5/8	713	28 1/16	392	15 7/16	305	12	TR 260 x 5	70	2 3/4	91	3 9/16	5	3/16	10960	669	427	940
	CSF-500F	250	9 7/8				585	23	673	26 1/2	835	32 7/8	923	36 5/16												18265	1115	515	1135

# HYDRAULIC CYLINDERS



CSE Series



## Flat cylinders

Working pressure: 700 kg/cm<sup>2</sup>/10.000 psi.

All pistons have a salt bath nitriding treatment to resist corrosion.

Grooved piston ends make optional grooved saddle unnecessary.

All are equipped with high flow female quick couplers with dust cap, ref A-5507-H, except model CSE-5 fitted with a female quick coupler, ref. A-5506-H.

With mounting holes in the base.

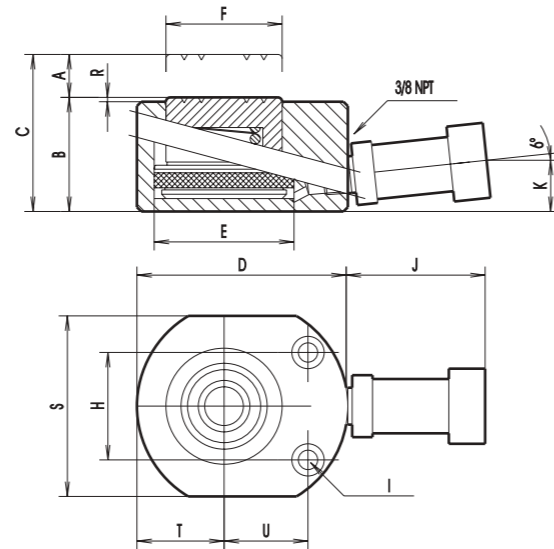

## Single-acting, spring-return

These CSE cylinders have been designed to combine minimum collapsed height with optimum stroke.

They are suitable for lifting, clamping, levelling or positioning jobs where space is tight.

The spring return piston allows easy removal from working place.



Cross section view

Nominal capacity tn	Ref.	Stroke		Maximum capacity kN	Effective area		Dimensions mm/in.														Oil volume		Weight													
		mm.	in.		cm <sup>2</sup>	in <sup>2</sup>	B	C	D	E	F	H	I	J	K	R	S	T	U	cm <sup>3</sup>	in <sup>3</sup>	Kg.	lbs.													
5	CSE-5	6,5	1/4	48,5	7,06	1,09	34	1 3/8	40,5	1 19/32	60	2 11/32	30	1 3/16	26	1 1/32	28	1 3/32	5,5	7/32	60	2 11/32	17	11/16	1	3/64	41	1 5/8	20	13/16	22	7/8	5	0,77	0,75	1,65
11	CSE-11	11	7/16	109,1	15,9	2,46	44,5	1 3/4	55,5	2 3/16	79	3 1/8	45	1 49/64	39	1 17/32	37	1 29/64	6,6	1/4	70	2 3/4	23	15/16	1	3/64	56	2 13/64	28	1 1/64	34	1 5/16	18	2,8	1,75	3,85
23	CSE-23	11	7/16	227,7	33,08	5,12	54	2 1/8	65	2 9/16	98	3 7/8	65	2 9/16	54	2 1/8	50	2	9	23/64	70	2 3/4	23	15/16	1	3/64	80	3 1/8	40	1 9/16	37	1 7/16	37	5,73	3,2	7,05
31	CSE-31	12	15/32	303,1	44,18	6,84	60	2 11/32	72	2 27/32	115	4 17/32	75	2 61/64	57,15	2 1/4	52	2 3/64	9	23/64	70	2 3/4	23	15/16	1	3/64	94	3 11/16	47	1 13/16	44	1 3/4	53	8,2	4,8	10,5
55	CSE-55	16	5/8	539	78,54	12,17	72	2 27/32	88	3 15/32	147	5 25/32	100	3 15/16	80	3 6/32	70	2 3/4	11	7/16	70	2 3/4	23	15/16	1	3/64	124	4 7/8	62	2 7/16	58	2 5/16	125	19,4	9,4	20,7
93	CSE-93	16	5/8	910,9	132,73	20,57	88	3 15/32	104	4 3/32	180	7 3/32	130	5 1/64	105	4 9/64	76	3	14	9/16	70	2 3/4	23	15/16	1	3/64	160	6 5/16	80	3 1/8	75	2 15/16	212	32,8	17,2	37,9

# HYDRAULIC CYLINDERS

CTN Series



## Pulling cylinders

Working pressure: 700 kg/cm<sup>2</sup>/10.000 psi.

All pistons have a hard chrome plating treatment to resist corrosion.

Equipped with high flow female quick coupler with dust cap, ref. A-5507-H and carrying handle.

Designed for pulling and tensioning applications, they can be used in those operations where two heavy pieces have to be put one near the other.

They are normally used in industrial assembling, testing, welding operations of plates or heavy steel frame works.

They are fitted with clevis eyes on both ends which are linked to attachments welded onto the plates to join or weld.

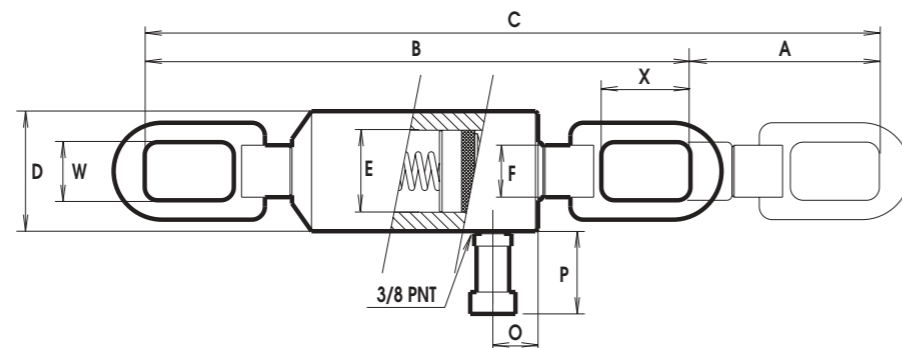

## Single-acting, spring return



Nominal capacity tn	Ref.	Stroke		Maximum capacity kN	Effective area		Dimensions mm/in.														Oil volume		Weight					
		mm.	in.		cm <sup>2</sup>	in <sup>2</sup>	B	C	D	E	F	O	P	W	X	cm <sup>3</sup>	in <sup>3</sup>	Kg.	lbs.									
10	CTN-10	127	5	98,95	14,42	2,23	475	18 11/16	625	24 9/16	85	3 11/32	60	2 11/32	42	1 21/32	35	1 3/8	70	2 3/4	40	1 9/16	75	2 15/16	183	11,15	9,6	21,1
30	CTN-30	150	5 15/16	331,8	48,34	7,49	625	24 9/16	775	30 1/2	125	4 15/16	100	3 15/16	62	2 7/16	40	1 9/16	70	2 3/4	50	2	100	3 15/16	725	44,3	22,1	48,6
50	CTN-50	150	5 15/16	497,2	72,45	11,23	770	30 5/16	920	36 7/32	155	6 1/8	125	4 15/16	80	3 9/32	44	1 3/4	70	2 3/4	60	2 11/32	150	5 15/16	1085	66,2	37	81,4

## Double-acting cylinders

Working pressure: 700 kg/cm<sup>2</sup>/10.000 psi.

All pistons have a salt bath nitriding treatment or a hard chrome plating, depending on the model, to resist corrosion and for longer life.

With built-in bronze guide for easier sliding of piston.

Fitted with a relief safety valve, ref. A-5538 on the piston retract side, to prevent accidental overpressure.

These cylinders are fitted with a removable grooved saddle, pressure mounted or screwed in the piston head. Are also equipped with a high flow female quick coupler with dust cap, ref. A-5507-H.

Carry handles on models weighing from 20 kg/44 lbs to 40 kg/88 lbs. Heavier models are fitted with eye hooks for transport.

With mounting holes and threaded areas protected against blows for easy coupling or special tooling applications.

## Hydraulic return



The hydraulic force being applied in both directions, these cylinders are very solid and used where a precision operation is required to move or position loads accurately on the assembly place. Widely demanded in public works and big structure manufacture.

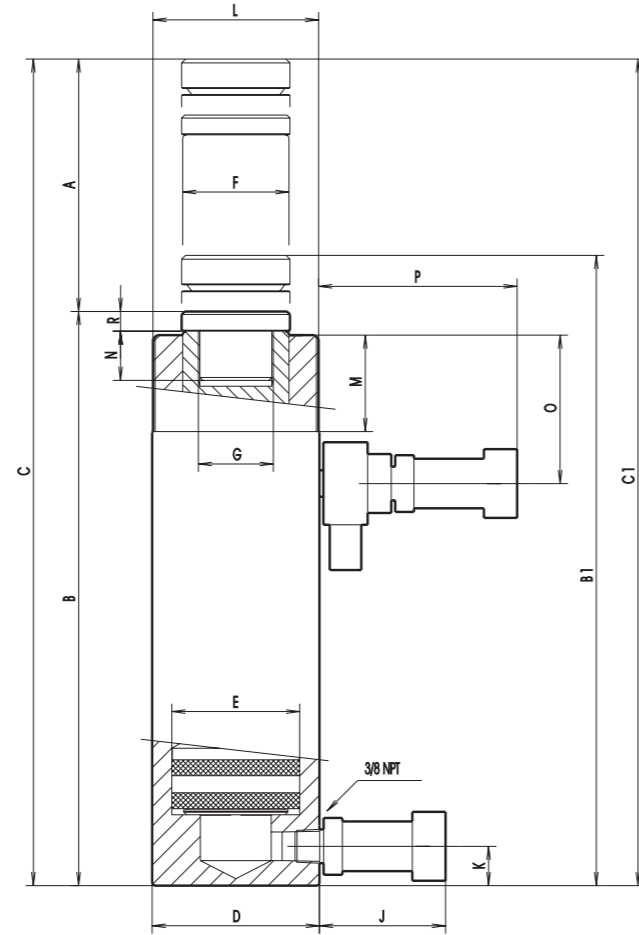

\*E= Pushing  
\*T= Pulling

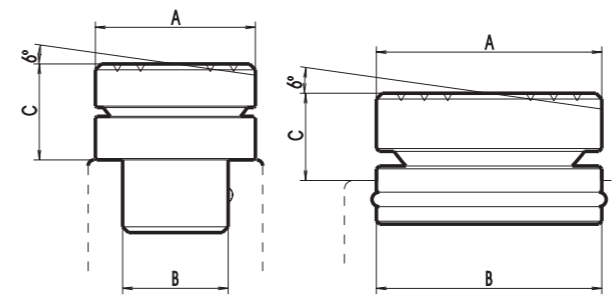

### Tilting saddle ( optional )

Ref.	Used with	Dimensions mm/in.					
		A		B		C	
BCSRA-11	CDRA-9	40	1 9/16	22,1	7/8	20	25/32
BCSRA-23	CDRA-23, CDRA-31	55	2 11/64	36,3	1 7/16	23	29/32
BCDRA-55	CDRA-55	65	2 9/16	22,7	57/64	40	1 9/16
BCDRA-93	CDRA-93	80	3 6/32	42,2	21/32	46	1 13/16
BCSB-200	CD-200	138	5 7/16	124	4 7/8	50	2
BCSB-300	CD-300	155	6 1/64	130	5 1/8	65	2 9/16
BCSB-400	CD-400	185	7 9/32	160	6 5/16	78	3 5/64
BCSB-500	CD-500	205	8 1/16	180	7 3/32	88	3 15/32

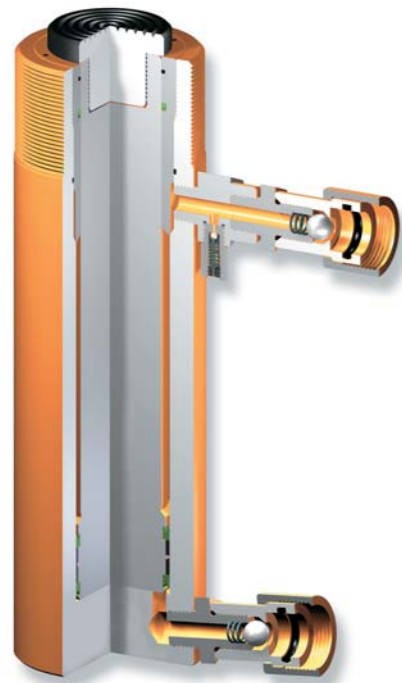

Cross section view

Nominal capacity tn	Ref.	Stroke mm. in.	Maximum capacity kN T	Effective area		B <sub>1</sub> , C <sub>1</sub> with tilting saddle																Oil volume		Weight															
				cm <sup>2</sup>	in <sup>2</sup>	Dimensions mm/in.																cm <sup>3</sup>	in <sup>3</sup>	Kg.	lbs.														
				E	T	B	B <sub>1</sub>	C	C <sub>1</sub>	D	E	F	G	J	K	L	M	N	O	P	R	E	T	E	T														
9	CDRA-9D	150 5 15/16	E 86,24 T 31,72	E 12,56 T 4,62	E 1,94 T 0,71	285	11 3/16	305	12	435	17 1/8	455	17 15/16	60	2 11/32	40	1 37/64	31,8	1 1/4	1 - 8 UNC	70	2 3/4	23	15/16	2 1/4 - 14 UNS	27	1 1/16	17	11/16	47	1 7/8	113	4 7/16	6	15/64	E 190 T 53	E 11,6 T 3,23	5,8	12,7
23	CDRA-23D	150 5 15/16	E 227,7 T 70,54	E 33,18 T 10,28	E 5,12 T 1,6	315	12 7/16	338	13 5/16	465	18 5/16	488	19 7/32	85	3 3/8	65	2 9/16	54	2 1/8	1 1/2 - 16 UN	70	2 3/4	23	15/16	3 5/16 - 12 UNS	49	1 15/16	25	1	70	2 3/4	113	4 7/16	10	25/64	E 500 T 155	E 30,5 T 9,46	10,4	22,9
31	CDRA-31D	150 5 15/16	E 303,1 T 127,3	E 44,18 T 18,55	E 6,84 T 2,87	338	13 5/16	363	14 9/32	488	19 7/32	513	20 3/16	100	3 15/16	75	2 61/64	57,15	2 1/4	1 1/2 - 16 UN	70	2 3/4	37	1 7/16	3 5/16 - 12 UNS	49	1 15/16	25	1	75	2 7/8	113	4 7/16	10	25/64	E 665 T 280	E 40,6 T 17,1	19,8	43,5
55	CDRA-55D	150 5 5/16	E 539 T 194,07	E 78,54 T 28,28	E 12,17 T 4,38	321	12 5/8	361	14 7/32	471	18 17/32	511	20 1/64	130	5 1/8	100	3 15/16	80	3 6/32	1 - 12 UNF	70	2 3/4	23	15/16	5 - 12 UN	45	1 3/4	38	1 1/2	65	2 9/16	113	4 7/16	15	19/32	E 1175 T 425	E 71,8 T 26	28,2	62
	CDRA-55F	250 9 7/8	E 1965 T 707	E 120 T 43,1	E 37 T 43,1	E 81,4 T 43,1																																	
93	CDRA-93D	150 5 5/16	E 910,9 T 316,6	E 132,73 T 46,14	E 20,57 T 7,15	355	14	401	15 3/4	505	19 7/8	551	21 11/16	175	6 7/8	130	5 1/8	105	4 9/64	1 3/4 - 12 UN	70	2 3/4	47	1 27/32	6 7/8 - 12 UN	50	2	50	2	70	2 3/4	113	4 7/16	15	19/32	E 1992 T 692	E 121,6 T 42,2	60,3	132,6
	CDRA-93F	250 9 7/8	E 3318 T 1154	E 202,5 T 70,5	E 77,3 T 70,5	E 170 T 70,5																																	
200	CD-200D	150 5 5/16	E 1945,8 T ----	E 283,52 T ----	E 43,95 T ----	356	14	406	16	506	19 15/16	556	21 7/8	242	9 9/16	190	7 1/2	150	5 15/16	----	70	2 3/4	62	2 7/16	----	----	----	----	65	2 9/16	113	4 7/16	5	3/16	E 4253 T 7088	E 260 T 432,7	135	297	
	CD-200F	250 9 7/8	E 7088 T ----	E 432,7 T ----	E 37 T ----	E 81,4 T ----																																	
300	CD-300D	150 5 5/16	E 2976,5 T ----	E 433,73 T ----	E 67,24 T ----	412	16 7/32	477	18 3/4	562	19 15/16	627	24 11/16	302	11 7/8	235	9 1/4	170	6 11/16	----	70	2 3/4	78	3 1/16	----	----	----	82	3 1/4	113	4 7/16	5	3/16	E 6506 T 10845	E 397 T 662	210	462		
	CD-300F	250 9 7/8	E 10845 T ----	E 662 T ----	E 261 T ----	E 574 T ----																																	
400	CD-400D	150 5 5/16	E 4017,1 T ----	E 585,35 T ----	E 90,75 T ----	417	16 13/32	495	19 1/2	567	22 5/16	645	25 3/8	349	13 3/4	270	10 5/8	210	8 1/4	----	70	2 3/4	84	3 5/16	----	----	----	90	3 9/16	113	4 7/16	5	3/16	E 8590 T 14315	E 525 T 87,4	301	662		
	CD-400F	250 9 7/8	E 14315 T ----	E 87,4 T ----	E 373 T ----	E 820 T ----																																	
500	CD-500D	150 5 5/16	E 5014 T ----	E 730,6 T ----	E 113,27 T ----	439	17 9/32	527	20 3/4	589	23 3/16	677	26 5/8	392	15 7/16	305	12	240	9 7/16	----	70	2 3/4	90	3 17/32	----	----	----	92	3 5/8	113	4 7/16	5	3/16	E 10960 T 18265	E 670 T 115	388	853		
	CD-500F	250 9 7/8	E 18265 T ----	E 115 T ----	E 476 T ----	E 1047 T ----																																	

# HYDRAULIC CYLINDERS

## Hollow piston cylinders

**CSH: SINGLE-ACTING**  
**CDH: DOUBLE-ACTING**

Working pressure: 700 kg/cm<sup>2</sup>/10.000 psi.

All pistons have a salt bath nitriding treatment to resist corrosion.

With built-in bronze guide for easier sliding of piston.

These cylinders are fitted with a removable saddle, and are also equipped with a high flow female quick coupler with dust cap, ref. A-5507-H.

Carry handles on models weighing from 20 kg/44 lbs to 40 kg/88 lbs. Heavier models are fitted with eye hooks for transport.

With mounting holes and threaded areas for easy coupling or special tooling applications.

Fitted with a relief safety valve, ref. A-5538, on the piston retract side, to prevent accidental overpressure.



**CSH: Single-acting, spring return**  
**CDH: Double-acting, hydraulic return**

The hollow cylinders can be used for general applications of pushing or lifting forces.

Additionally, they feature a centre-hole piston which allows the insertion of a rod or screw, attachable to the threaded saddle, that travels through the cylinder for pulling or pushing operations.

Ideal for tensioning, extracting, gear and pin removal etc.

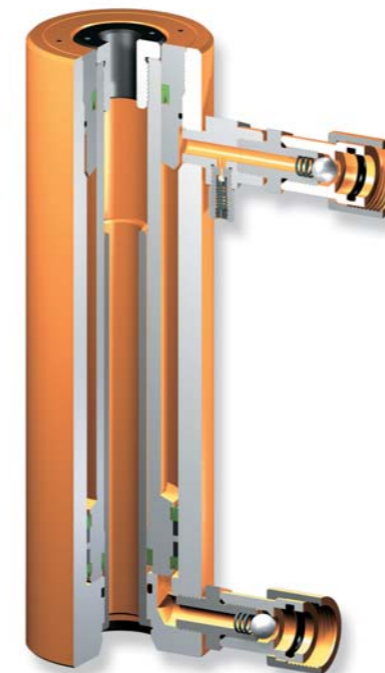
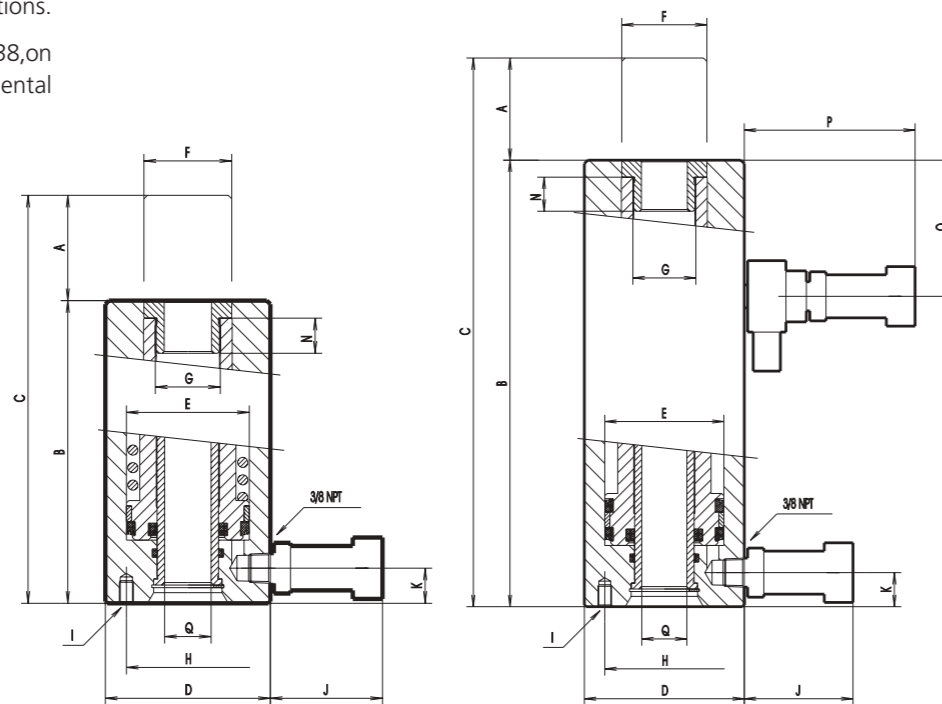

Cross section view (CDH)

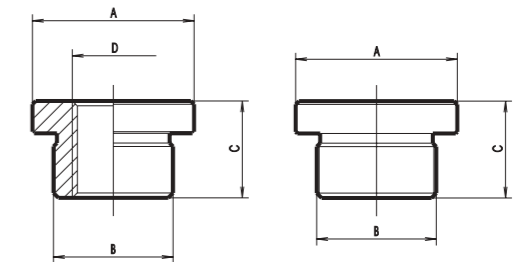

- Threaded saddle (optional)
- Grooved saddle (optional)

Ref.	Used with	Dimensions mm/in.							
		A	B	C	D	E	F	G	H
BRCSH-12	CSH-12	38	1 1/2	M29 x 15	28	1 1/4	3/4 - 16 UNF	---	---
BMCSH-12		27,2	1 5/8	27,2	1 1/4	---	---	---	---
BRCSH-20	CSH-20	50	2	M37 x 1,5	30	1 3/16	1 - 8 UNC	---	---
BMCSH-20		35,2	1 25/64	35,2	1 1/8	---	---	---	---
BRCSH-30	CSH-30, CDH-30	61	2 13/32	M46 x 1,5	32	1 1/4	1 1/4 - 7 UNC	---	---
BMCSH-30		44,2	1 3/4	44,2	1 1/4	---	---	---	---
BRCSH-60	CSH-60, CDH-60	93	3 21/32	M72 x 1,5	37	1 29/64	1 5/8 - 5 1/2 UNS	---	---
BMCSH-60		70,2	2 49/64	70,2	1 1/2	---	---	---	---
BMCSH-90	CSH-90, CDH-90	127	5	M104 x 1,5	42	1 21/32	---	---	---

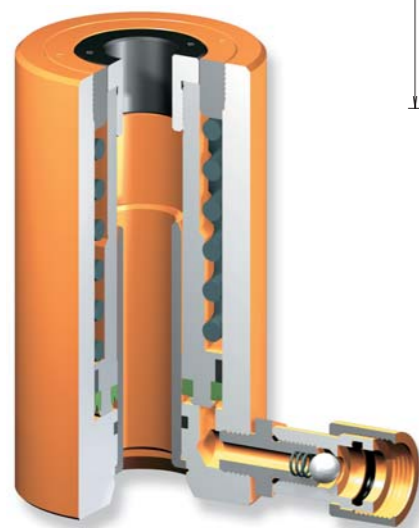

Cross section view (CSH)

Nominal capacity tn	Ref.	Stroke		Maximum capacity kN	Effective area		Dimensions mm/in.															Oil volume		Weight												
		mm.	in.		cm <sup>2</sup>	in <sup>2</sup>	B	C	D	E	F	G	H	I	J	K	N	O	P	Q	cm <sup>3</sup>	in <sup>3</sup>	Kg.	lbs.												
		12	CSH-12		41	1 5/8	119,3	18,03	2,8	145	5 11/16	186	7 5/16	70	2 3/4	55	2 11/64	38,5	1 23/64	M29 x 1,5	50,8	2	5/16 - 18 UNC	70	2 3/4	20	25/32	20	25/32	---	---	19,5	49/64	74	4,5	3,8
20	CSH-20	48	1 7/8	196,6	28,86	4,5	172	6 3/4	220	8 11/16	95	3 3/4	70	2 3/4	50,5	2	M37 x 1,5	82,6	3 1/4	3/8 - 16 UNC	70	2 3/4	20	25/32	20	25/32	---	---	26,5	1 3/64	140	8,5	8	17,6		
30	CSH-30	63	2 1/2	291,7	42,51	6,6	200	7 7/8	263	10 3/8	110	4 5/16	85,72	3 3/8	62	2 7/16	M46 x 1,5	92,1	3 5/8	3/8 - 16 UNC	70	2 3/4	20	25/32	22	7/8	---	---	33	1 19/64	270	16,5	13	28,6		
60	CSH-60	76	3	578,8	84,34	13	245	9 5/8	321	12 5/8	155	6 1/8	125	4 15/16	94	3 45/64	M72 x 1,5	130,2	5 1/8	1/2 - 13 UNC	70	2 3/4	20	25/32	25	1	---	---	53,5	2 1/64	640	39	26,6	58,5		
90	CSH-90	76	3	867	133	20,6	272	10 11/16	348	13 11/16	200	7 7/8	165,1	6 1/2	128	5 3/64	M104 x 1,5	---	---	---	70	2 3/4	38	1 1/2	30	1 3/16	---	---	79	3 1/64	1010	61,6	65	143		
30	CDH-30	150	5 15/16	291,7	42,51	6,6	296	11 11/16	446	17 9/16	110	4 5/16	85,72	3 3/8	62	2 7/16	M46 x 1,5	92,1	3 5/8	3/8 - 16 UNC	70	2 3/4	20	25/32	22	7/8	47	1 27/32	113	4 7/16	33	1 19/64	638	39	19,2	42,2
60	CDH-60	150	5 15/16	578,8	84,34	13	302	11 7/8	452	17 13/16	155	6 1/8	125	4 15/16	94	3 45/64	M72 x 1,5	130,2	5 1/8	1/2 - 13 UNC	70	2 3/4	20	25/32	25	1	48	1 7/8	113	4 7/16	53,5	2 1/64	1265	77,2	32,7	72
90	CDH-90	150	5 15/16	880	133	20,6	310	12 3/16	460	18 1/64	200	7 7/8	165,1	6 1/2	128	5 3/64	M104 x 1,5	---	---	---	70	2 3/4	38	1 1/2	30	1 3/16	50	2	113	4 7/16	79	3 1/64	1995	121,8	74	163

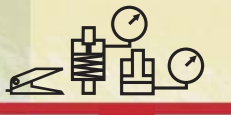

## Spread cylinder

### SH-1

Spring return

Capacity: 1 t

Weight: 3,5kg / 7,7lbs

Fitted with female quick coupler, ref. A-5506-H.

Widely used for spreading operations in tight spaces where a high force is required.

This hydraulic tool is a component of the Maintenance Kits described on page 35.

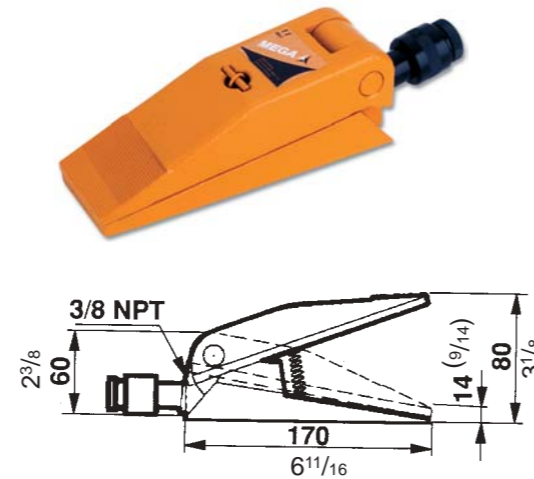

## Load cells

### TDM-10 - 10t

Tension load cell

Designed for measuring applications and pull test.

Precision: ± 2,5%.

### CDM-10 - 10t

Compression load cell

Widely used as a load cell in presses, clamps etc.

Precision: ± 2,5%.

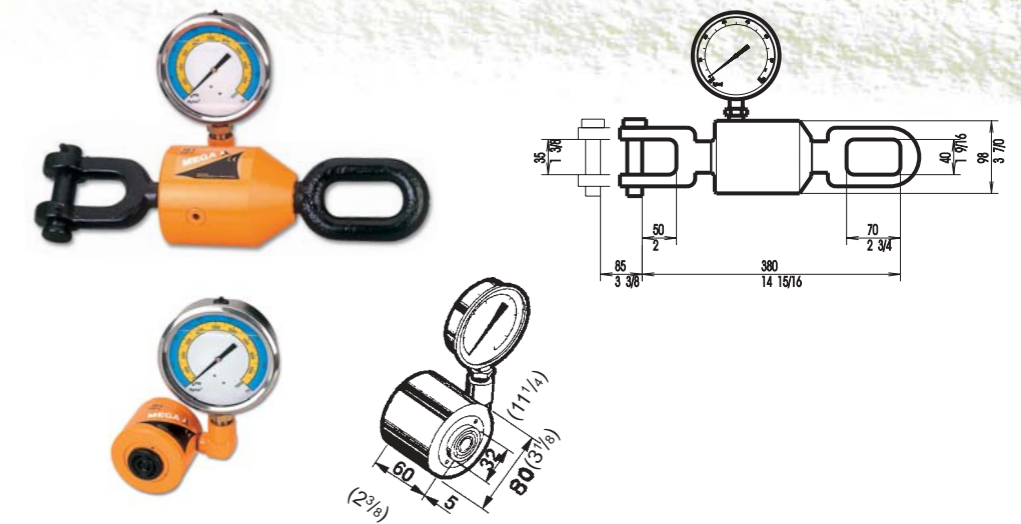

## Hydraulic bolt tensioners

Working pressure: 1.500 kg/cm<sup>2</sup>/21.430 psi.

A bolt tensioner is a hydraulic hollow cylinder with an internally threaded piston which is attached into a bolt.

The application of a hydraulic force to the cylinder stretches the bolt.

The nut can be then tightened with the aid of a rod inserted in a hole previously drilled on the nut.

The supporting ring of the bolt tensioner has an opening for an easier tightening operation.



## THS: Single cylinder / THD: Double cylinder

The THD bolt tensioners feature same characteristics as those of the THS series, although they have a double cylinder for use where space is tight.

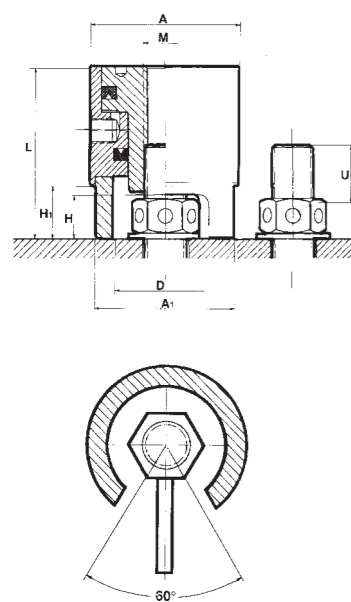

Ref.	Metric thread	Stroke A mm. in.	Maximum capacity kN	Effective area cm <sup>2</sup> in <sup>2</sup>	Dimensions mm/in.							Weight		
					A	A <sub>1</sub>	D	H	H <sub>1</sub>	L	U	Kg.	lbs.	
THS-20	M-20	8	321,3	21,85	77	72	54	23	27	90	20	13/16	2,5	5,5
THS-22	M-22	8	321,3	21,85	77	72	54	23	27	90	22	7/8	2	4,4
THS-24	M-24	8	321,3	21,85	77	72	54	23	27	90	24	15/16	1,8	4
THS-27	M-27	8	321,3	21,85	77	72	54	23	27	90	27	1 1/16	1,6	3,5
THS-30	M-30	8	321,3	21,85	77	72	54	23	27	90	30	1 3/16	6	13,2
THS-33	M-33	8	692,45	47,12	112	100	77	30	40	104	33	1 5/16	5,5	12,1
THS-36	M-36	8	692,45	47,12	112	100	77	30	40	104	36	1 7/16	5	11
THS-39	M-39	8	692,45	47,12	112	100	77	30	40	104	39	1 9/16	4,5	9,9
THS-42	M-42	8	692,45	47,12	112	100	77	30	40	104	42	1 11/16	13	28,6
THS-45	M-45	8	1302,2	88,56	153	136	102	40	54	128	45	1 13/16	12,5	27,5
THS-48	M-48	8	1302,2	88,56	153	136	102	40	54	128	48	1 15/16	11,5	25,3
THS-52	M-52	8	1302,2	88,56	153	136	102	40	54	128	52	2 3/64	10,5	23,1
THS-56	M-56	8	1302,2	88,56	153	136	102	40	54	128	56	2 7/32	26	57,3
THS-60	M-60	8	2057,6	139,92	198	187	131	52	74	160	60	2 3/8	25	55,1
THS-64	M-64	8	2057,6	139,92	198	187	131	52	74	160	64	2 9/16	24	53
THS-68	M-68	8	2057,6	139,92	198	187	131	52	74	160	68	2 11/16	23	50,7
THS-72	M-72	8	2057,6	139,92	198	187	131	52	74	160	72	2 13/16	22	48,5
THS-76	M-76	10	2642	179,66	227	208	152	58	85	186	76	3	37,5	82,6
THS-80	M-80	10	2642	179,66	227	208	152	58	85	186	80	3 3/16	36	79,3
THS-85	M-85	10	2642	179,66	227	208	152	58	85	186	85	3 3/8	34,5	76
THS-90	M-90	10	3638,2	247,4	263	245	185	70	102	216	90	3 9/16	57	125
THS-95	M-95	10	3638,2	247,4	263	245	185	70	102	216	95	3 3/4	55	121
THS-100	M-100	10	3638,2	247,4	263	245	185	70	102	216	100	3 15/16	53	116

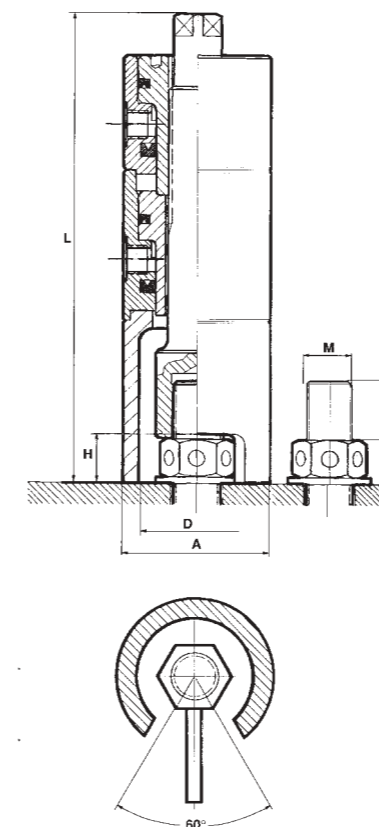

Ref.	Metric thread	Stroke A mm. in.	Maximum capacity kN	Effective area cm <sup>2</sup> in <sup>2</sup>	Dimensions mm/in.							Weight		
					A	A <sub>1</sub>	D	H	H <sub>1</sub>	L	U	Kg.	lbs.	
THD-20	M-20	8	321,3	21,85	77	72	54	23	27	90	20	13/16	5	11
THD-22	M-22	8	321,3	21,85	77	72	54	23	27	90	22	7/8	4,5	10
THD-24	M-24	8	321,3	21,85	77	72	54	23	27	90	24	15/16	4	8,8
THD-27	M-27	8	321,3	21,85	77	72	54	23	27	90	27	1 1/16	3,5	7,7
THD-30	M-30	8	321,3	21,85	77	72	54	23	27	90	30	1 3/16	11	24,2
THD-33	M-33	8	692,45	47,12	112	100	77	30	40	104	33	1 5/16	10	22
THD-36	M-36	8	692,45	47,12	112	100	77	30	40	104	36	1 7/16	9,5	21
THD-39	M-39	8	692,45	47,12	112	100	77	30	40	104	39	1 9/16	8,8	19,4
THD-42	M-42	8	692,45	47,12	112	100	77	30	40	104	42	1 11/16	24	53
THD-45	M-45	8	1302,2	88,56	153	136	102	40	54	128	45	1 13/16	22,5	49,6
THD-48	M-48	8	1302,2	88,56	153	136	102	40	54	128	48	1 15/16	21	46,3
THD-52	M-52	8	1302,2	88,56	153	136	102	40	54	128	52	2 3/64	19,5	43
THD-56	M-56	8	1302,2	88,56	153	136	102	40	54	128	56	2 7/32	40	88,2
THD-60	M-60	8	2057,6	139,92	198	187	131	52	74	160	60	2 3/8	38	83,8
THD-64	M-64	8	2057,6	139,92	198	187	131	52	74	160	64	2 9/16	36	79
THD-68	M-68	8	2057,6	139,92	198	187	131	52	74	160	68	2 11/16	35	77
THD-72	M-72	8	2057,6	139,92	198	187	131	52	74	160	72	2 13/16	33	72,7
THD-76	M-76	10	2642	179,66	227	208	152	58	85	186	76	3	60	132
THD-80	M-80	10	2642	179,66	227	208	152	58	85	186	80	3 3/16	57	125
THD-85	M-85	10	2642	179,66	227	208	152	58	85	186	85	3 3/8	54	119

# HYDRAULIC PUMPS



BK  
BK  
BMD Series

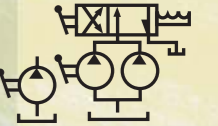

## Single-acting hand pumps

### BM-04, BM-1, BM-2 and BMAP-1

All are single acting, one-speed hand pumps, and can be used as a portable hydraulic tool or in a fixed position. They can operate both in a horizontal or vertical position. In this case, the pump head should be placed downwards. Their light weight and small oil volume make them a very useful pump where a quick action is required. They are fitted with a safety relief valve, factory rated at the maximum working pressure.

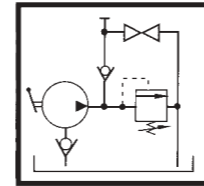

Hydraulic diagram



### BM-3, BMAP-3, BM-6 and BM-12

Single-acting, two-speed hand pumps. The two-stage automatic system allows the operation of both pistons for a quick approach of the cylinder to load. The larger pump piston cuts out when the cylinder activated by the pump is under high pressure. All fitted with a safety relief valve, factory rated at the maximum working pressure.

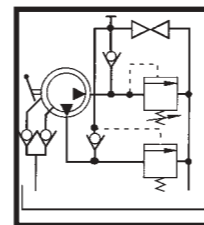

Hydraulic diagram



### BK-05, BK-09

Vertical hand pumps. Single and two-speed. Fitted with holes in the pump base to be used as a fixed hydraulic tool.

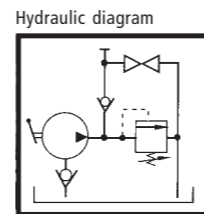

Hydraulic diagram

## Double-acting hydraulic hand pumps

### BMD-3, BMD-6 and BMD-12

These are double acting and two-speed hand pumps. They all feature same technical advantages as the single acting one-speed pumps. With a safety relief valve, factory rated at the maximum working capacity.

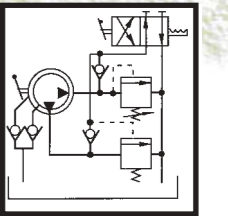

Hydraulic diagram

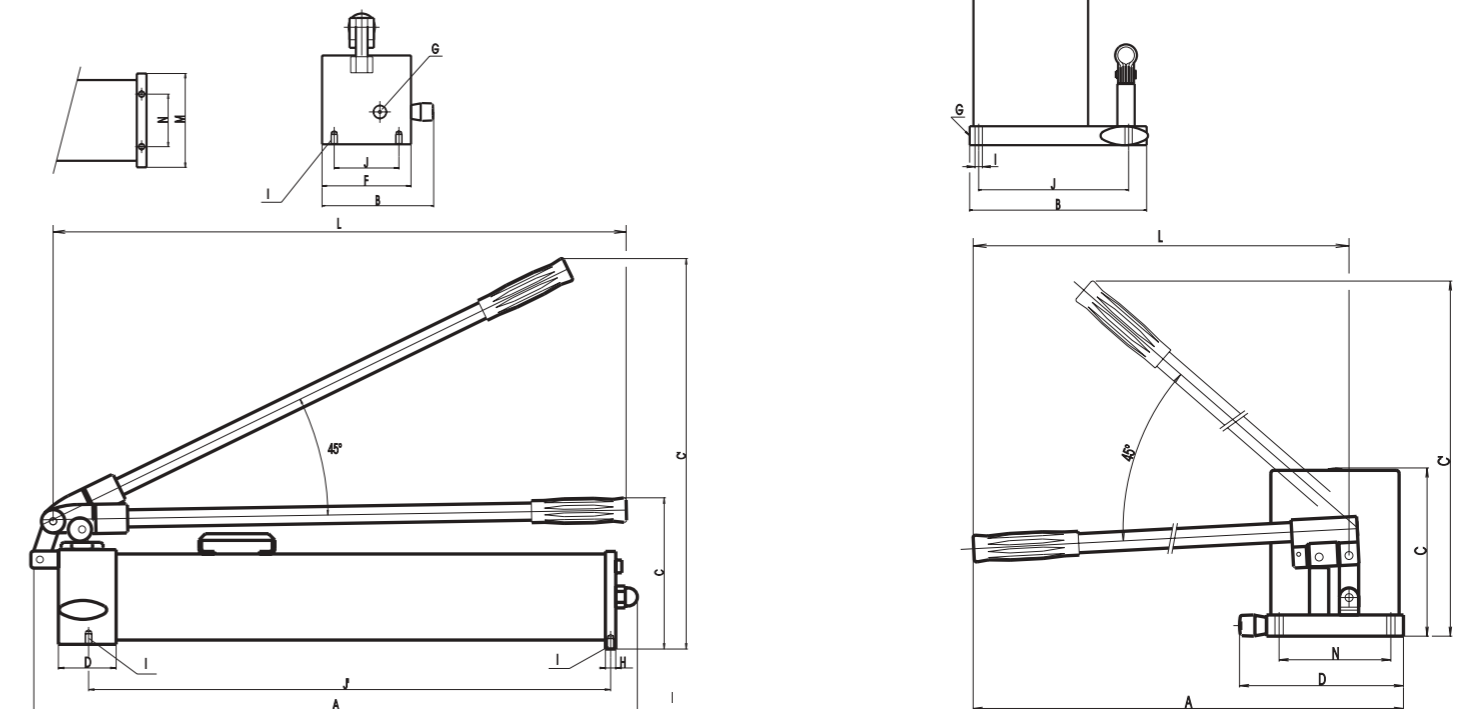

Vertical pump

Ref.	Working pressure		Effective oil volume		Oil flow per stroke		Dimensions mm/in.														Weight														
	kg/cm <sup>2</sup>	psi	cm <sup>3</sup>	in <sup>3</sup>	1st stage cm <sup>3</sup> in <sup>3</sup>	2nd stage cm <sup>3</sup> in <sup>3</sup>	A	B	C	C'	D	F	G	H	I	J	J'	L	M	N	Kg.	lbs.													
BM-04	700	10000	400	24,4	-	2,5 0,15	460	18 1/64	127	5	137	5 13/32	440	17 5/16	30	1 3/16	97	3 13/16	3/8-18NPT	33	1 5/16	8,5	11/32	-	-	-	-	400	15 3/4	-	-	50	2	4,25	9,4
BM-1	700	10000	1250	76,3	-	2,5 0,15	590	23 7/32	133	5 1/4	155	6 1/64	610	24	30	1 3/16	104	4 1/64	3/8-18NPT	33	1 5/16	8,5	11/32	-	-	-	-	600	23 5/8	-	-	80	3 6/32	6,7	14,8
BM-2	700	10000	2000	122	-	2,5 0,15	570	22 7/16	155	6 1/64	175	6 7/8	630	14 13/16	30	1 3/16	140	5 1/2	3/8-18NPT	33	1 5/16	8,5	11/32	-	-	-	-	600	23 5/8	-	-	90	3 9/16	12	26,5
BMAP-1	1500	21430	1250	76,3	-	1 0,06	590	23 7/32	142	5 5/8	155	6 1/64	610	24	30	1 3/16	112	4 7/16	1/4-19GAS	33	1 5/16	8,5	11/32	-	-	-	-	600	23 5/8	-	-	80	3 6/32	7,2	15,9
BK-05	700	10000	650	39,7	-	2,5 0,15	625	24 5/8	180	7 3/32	144	5 11/16	610	24	140	5 1/2	-	-	3/8-18NPT	-	-	8,5	11/32	-	-	-	-	600	23 5/8	-	-	96	3 3/4	7	15,4
BKD-09	700	10000	1100	67,1	8	0,5 2,5 0,15	625	24 5/8	228	8 15/16	233	9 3/16	610	24	140	5 1/2	-	-	3/8-18NPT	-	-	8,5	11/32	-	-	-	-	600	23 5/8	-	-	96	3 3/4	9,5	20,9
BM-3	700	10000	3000	183	19	1,15 2,5 0,15	700	27 9/16	135	5 5/16	185	7 9/32	595	23 7/16	67	2 5/8	110	4 5/16	3/8-18NPT	12	15/32	M8x1,25	80	3 6/32	607	23 7/8	665	26 3/16	80	3 6/32	65	2 9/16	14	30,9	
BMAP-3	1500	21430	3000	183	18	1,1 1,15 0,07	700	27 9/16	135	5 5/16	185	7 9/32	595	23 7/16	67	2 5/8	110	4 5/16	1/4-19GAS	12	15/32	M8x1,25	80	3 6/32	607	23 7/8	665	26 3/16	80	3 6/32	65	2 9/16	14	30,9	
BM-6	700	10000	6000	366	19	1,15 2,5 0,15	700	27 9/16	168	6 5/8	185	7 9/32	595	23 7/16	67	2 5/8	110	4 5/16	3/8-18NPT	10	25/64	M6x1	130	5 1/8	-	-	665	26 3/16	165	6 1/2	-	-	20	44,1	
BM-12	700	10000	12000	732	19	1,15 2,5 0,15	700	27 9/16	290	11 7/16	185	7 9/32	595	23 7/16	67	2 5/8	110	4 5/16	3/8-18NPT	10	25/64	-	-	-	-	665	26 3/16	290	11 7/16	-	-	25	55,1		
BMD-3	700	10000	3000	183	19	1,15 2,5 0,15	730	27 9/16	146	5 3/4	185	7 9/32	595	23 7/16	125	4 15/16	110	4 5/16	3/8-18NPT	12	15/32	M8x1,25	80	3 6/32	607	23 7/8	665	26 3/16	80	3 6/32	65	2 9/16	17	37,5	
BMD-6	700	10000	6000	366	19	1,15 2,5 0,15	730	27 9/16	168	6 5/8	185	7 9/32	595	23 7/16	125	4 15/16	110	4 5/16	3/8-18NPT	10	25/64	M6x1	130	5 1/8	-	-	665	26 3/16	165	6 1/2	-	-	23	50,7	
BMD-12	700	10000	12000	732	19	1,15 2,5 0,15	730	27 9/16	290	11 7/16	185	7 9/32	595	23 7/16	125	4 15/16	110	4 5/16	3/8-18NPT	10	25/64	-	-	-	-	665	26 3/16	290	11 7/16	-	-	28	61,7		

# HYDRAULIC PUMPS



NS  
NAP  
BKN Series



## Air hydraulic pumps

### NS-1, NS-21, NS-22 and NAP-3

Single-acting, one-speed air pumps.

Air driven pumps for operation where electric power is not available or dangerous.

With safety relief valve, factory rated at the maximum working pressure.

Once the NS-1, NS-21 and NS-22 air pumps are connected to the air line, press down on the back section of pedal for operation. Descent or pressure release is effected by pressing down on the front section.

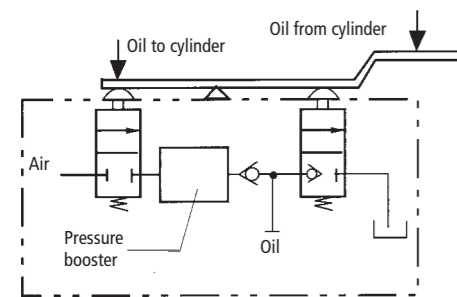

Recommended air pressure:  
7-10 kg/cm<sup>2</sup> / 100-140 psi  
Minimum air flow:  
270 l/min. / 59,39 gpm

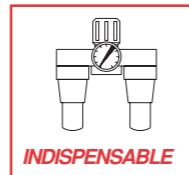

**Important.** It is recommended the use of an air filter-regulator-lubricator unit with these pumps to resist corrosion and for longer life.

## Single-acting

### BKN-09

Manual and air powered pump.

The pneumatic operation allows for a faster movement of the piston.

The manual operation is required for precision pressing jobs or when compressed air supply is not available.

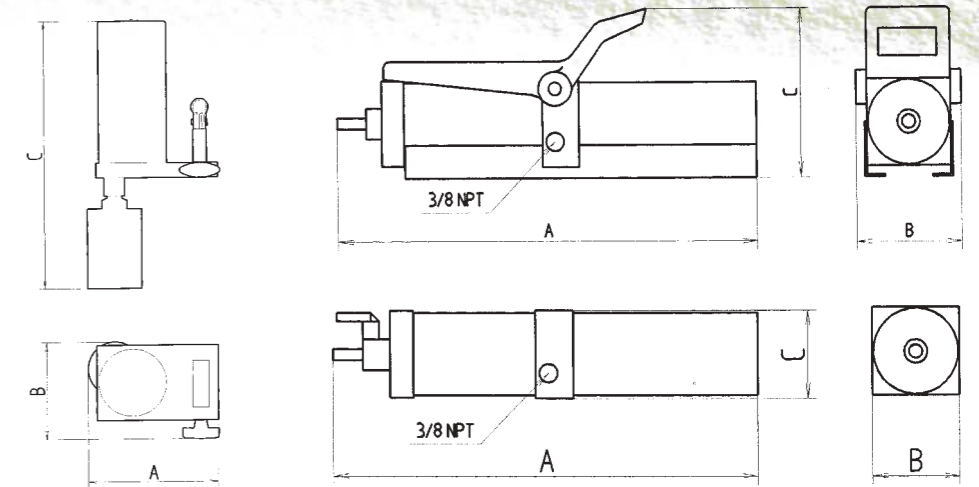

Ref.	Working pressure		Effective oil volume		Oil flow		Oil flow per stroke		Dimensions mm/in.			Weight				
	kg/cm <sup>2</sup>	psi.	cm <sup>3</sup>	in <sup>3</sup>	cm <sup>3</sup> /min	in <sup>3</sup> /min	cm <sup>3</sup>	in <sup>3</sup>	A	B	C	Kg.	lbs.			
NS-1	700	10000	500	30,5	50	3,05	-	-	440	17 5/16	120	4 3/4	150	5 7/8	7	15,5
NS-21	700	10000	1250	76,3	50	3,05	-	-	697	27 7/16	120	4 3/4	150	5 7/8	8	17,6
NS-22	225	3215	1000	61	155	9,45	-	-	606	23 7/8	120	4 3/4	150	5 7/8	7,6	16,7
NAP-3	1500	21430	3000	183	43	2,6	-	-	800	31 1/2	120	4 3/4	120	4 3/4	15	33
BKN-09	700	10000	1100	67,1	50	3,05	2,5	0,15	193	7 5/8	140	5 1/2	407	16	8,2	18

# HYDRAULIC PUMPS

## Electric pumps

### BES-5, BES-10, BES-20 and BES-30: SINGLE-ACTING

### BED-5, BED-10, BED-20 and BED-30: DOUBLE ACTING

They have a two-stage, radial pump that provides a working pressure of 700 kg/cm<sup>2</sup>/10.000 psi.

The first stage allows a quick approach of piston to load and the second stage gives the effective working pressure.

With precision made components, electric power provides improved operation for applications requiring high pressure.

With safety relief valve, factory rated at the maximum working pressure. For a continuous operation, pressure should not exceed 560 kg/cm<sup>2</sup>/8.000 psi.

Frequency: 50 Hz.: 220/380 V - 1,5 kW - 2 HP - 1400 rpm.

Frequency: 60 Hz.: 265/460 V - 1,7 kW - 2,3 HP - 1700 rpm.



## BES: single-acting BED: double-acting

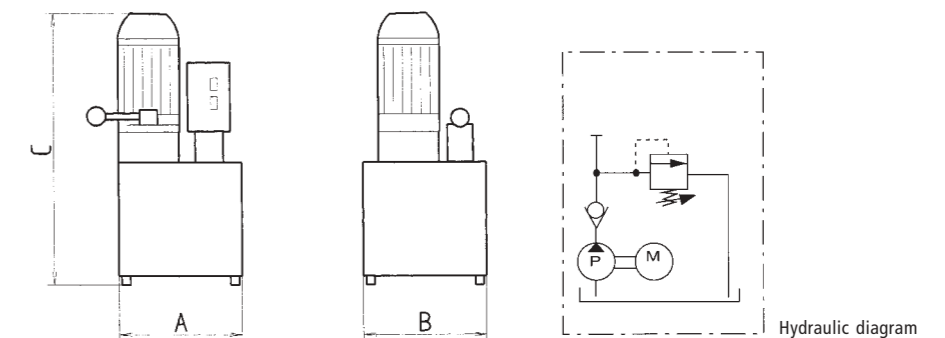

Ref.	Working pressure		Effective oil volume		Power	R.p.m.	Oil flow				Dimensions mm/in.			Weight				
	kg/cm <sup>2</sup>	psi.	l.	Gal.			1st stage		2nd stage		A	B	C	Kg.	lbs.			
							l/min	in <sup>3</sup> /min	l/min	in <sup>3</sup> /min								
BES-5	700	10000	5	1,32	0,552	1390	0,8	48,8	0,5	30,5	215	8 1/2	250	9 7/8	443	17 7/16	36	79
BES-10	700	10000	10	2,65	0,736	1400	1,1	67	0,7	42,7	285	11 1/4	255	10	485	19 3/32	48	106
BES-20	700	10000	20	5,3	1,472	1390	2,1	128	1,3	79,3	325	12 3/4	325	12 3/4	615	24 3/16	73	161
BES-30	700	10000	30	7,95	1,472	1390	2,1	128	1,3	79,3	365	14 3/8	365	14 3/8	625	24 5/8	95	210
BED-10	700	10000	10	2,65	0,736	1400	1,1	67	0,7	42,7	285	11 1/4	255	10	485	19 3/32	48	106
BED-20	700	10000	20	5,3	1,472	1390	2,1	1,28	1,3	79,3	325	12 3/4	325	12 3/4	615	24 3/16	73	161
BED-30	700	10000	30	7,95	1,472	1390	2,1	1,28	1,3	79,3	365	14 3/8	365	14 3/8	625	24 5/8	95	210

## Thermoplastic hoses

The references MAP and MCE are high pressure flexible hoses made of a polyester elastomer tube, reinforced with a braid of polyaramid yarn, a polyester interlay, a single braid of carbon steel wire and an outer polyurethane cover.

Minimum burst pressure: 2.800 kg/cm<sup>2</sup> / 40.000 psi

MAPS-1,5 flexible hose is made of an inner polyethylene tube (POM), with four spiral steel wire braids and a polyamide cover.

Minimum burst pressure: 4.400 kg/cm<sup>2</sup> / 63.800 psi

As an option, the 1,5 m hoses are supplied with a quick coupler included.

The MEC-3 and MEC-6 hoses are specially designed for operation with electric powered pumps.



Ref.	Working pressure		Interior		Interior		Connection thread	Quick coupler
	kg/cm <sup>2</sup>	psi.	Ø mm	in.	m.	in.		
MAP-06	700	10000	6,4	1/4	0,6	23,6	3/8 x 18 NPT	----
MAP-1	700	10000	6,4	1/4	1	39,4	3/8 x 18 NPT	----
MAP-1,5	700	10000	6,4	1/4	1,5	59	3/8 x 18 NPT	----
MAP-2	700	10000	6,4	1/4	2	78,8	3/8 x 18 NPT	----
MAP-3	700	10000	6,4	1/4	3	118	3/8 x 18 NPT	----
MAP-6	700	10000	6,4	1/4	6	236	3/8 x 18 NPT	----
MAPS-1,5	1760	25520	5	19/16	1,5	59	1/4 x 19 GAS	----
MCE-3	700	10000	9,8	3/8	3	118	3/8 x 18 NPT	----
MCE-6	700	10000	9,8	3/8	6	236	3/8 x 18 NPT	----
A-5555	700	10000	6,4	1/4	1,5	59	3/8 x 18 NPT	A-5507-M
A-5588	700	10000	6,4	1/4	1,5	59	3/8 x 18 NPT	A-5506-M
A-5559	1760	25520	5	19/16	1,5	59	1/4 x 19 GAS	A-5537-H

## Glycerine gauges

The gauges permit the reading of the pressure generated by the pump or the force applied by the cylinder, which provides safety of use, avoids damage to the equipment and guarantees longer life.

Precision: ± 2,5%.

The pressure and force are indicated in kg/cm<sup>2</sup>, psi and tonnes.

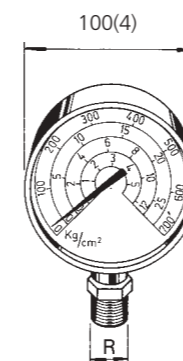

Ref.	Used with	Interior	Connection thread R
A-5580G	CSRA-5/CSRA-11/CSB-11/CSE-5/CSE-11 SERIES	5-11 TNS	3/8 GAS
A-5581G	CSRA-16/CSRA-23/CSB-23/CSE-23/CDRA-23 SERIES	16-23 TNS	3/8 GAS
A-5582G	CSRA-31/CSRA-55/CSB-31/CSB-55/CSE-31/CSE-55/CSF-31/CSF-55/CDRA-31/CDRA-55 SERIES	31-55 TNS	3/8 GAS
A-5583G	CSRA-93/CSB-93/CSE-93/CSF-93/CDRA-93/CSE-31/CSE-55 SERIES	93 TNS	3/8 GAS
A-5584G	CSH-12/CSH-20 SERIES	12-20 TNS	3/8 GAS
A-5585G	CSH-30/CSH-60/CDH-30/CDH-60 SERIES	30-60 TNS	3/8 GAS
A-5586G	GENERAL APPLICATIONS	0-700 kg/cm <sup>2</sup>	3/8 GAS
A-5587G	USO GENERAL APPLICATIONS	0-1600 kg/cm <sup>2</sup>	1/2 NPT

## Coupling

The high flow quick couplers allow a fast and safe connection of the different components in the hydraulic applications. They consist of two halves, oil tight, called male and female, and have dust caps to prevent entry of dirt.

Supplied according to the reference on the chart.

### A-5507

Maximum flow: 17 l/min/1.038 in<sup>3</sup>/min. Pressure: up to 700 kg/cm<sup>2</sup>/10.000 psi.



### A-5506

Maximum flow: 2 l/min/122 in<sup>3</sup>/min. Pressure: up to 700 kg/cm<sup>2</sup>/10.000 psi.



### A-5537

Maximum flow: 7 l/min/427 in<sup>3</sup>/min. Pressure: up to 1.500 kg/cm<sup>2</sup>/21.430 psi.



Referencia	Description	Characteristics
A-5507	Complete coupler	
A-5507-M	Male quick coupler	
A-5507-H	Female quick coupler	
A-5506	Complete coupler	
A-5506-M	Male quick coupler	
A-5506-H	Female quick coupler	
A-5537	Complete coupler	
A-5537-H	Male quick coupler	
A-5537-M	Female quick coupler	

## Adapters

These adapters allow an easy way of fitting the gauge into cylinder or pump.



On page 7 of this catalogue, instructions are given for better information and use of the accessories described. Read pages 4 and 5, carefully.

Ref.	Description	Working pressure	Characteristics
		kg/cm <sup>2</sup> psi.	
A-5501	Gauge adapter	700 10000	
A-5558	Gauge adapter	1500 21430	
MGK-15	Gauge adapter plug	700 10000	
NAP-3	Gauge adapter plug	1500 21430	





## Valves

A hydraulic application can be effected through several configurations, some of which are indicated on page 7 of this catalogue. None of the configurations described could be carried out without the accessories and fittings described.



### A-5509 Shutoff valve

Shuts the oil flow. It also locks the load on a raised cylinder.

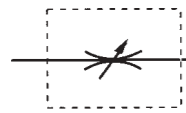

### A-5510 Safety valve

Locks the load on a raised cylinder.

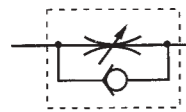

### A-5570 Lowering control valve

Prevents sudden lowering of load by producing a resistance to the oil flow.

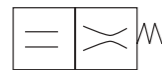

### A-5538 Safety relief valve

Avoids accidental overpressure.

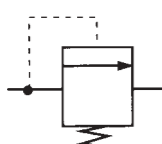

Reference	Description	Working pressure		Characteristics
		kg/cm <sup>2</sup>	psi.	
A-5509	Shutoff valve	700	10000	
A-5510	Safety valve	700	10000	
A-5570	Lowering control valve	700	10000	
A-5538	Safety relieve valve	700	10000	

## Connectors. Spares

### A-5583 and A-5574. Manifolds

Although only two manifolds are described in this catalogue, we can manufacture and supply other manifolds with the number of ways required

### MEGA hydraulic oil

High quality hydraulic oil for the essential parts of the hydraulic tools

Indispensable for a continuous or intensive use of the MEGA pumps and cylinders.

Delivered in 2 and 5 litre plastic container.

A-5535. 2 litre plastic container

A-5536. 5 litre plastic container



### Repair kits

A repair kit is available for every hydraulic item in this catalogue.

The reference of the article for which the kit is intended should be clearly indicated.



Reference	Description	Working pressure		Characteristics
		kg/cm <sup>2</sup>	psi.	
A-5583	Five-way manifold	700	10000	
A-5574	Two-way manifold	1500	21430	
A-5511	Male connector	700	10000	
A-5579	Male connector	700	10000	
A-5513	Mixed connector	700	10000	
A-5589	Mixed connector	700	10000	
A-5512	Female connector	700	10000	
A-5590	Female connector	700	10000	
Y-2/1160	Coned plug	700	10000	
A-5591	Male plug	700	10000	
A-5514	Elbow	1500	21430	
A-5566	Metallplastic washer	1500	21430	

## Grip and rod pullers

### Rod pullers

The rod end is threaded into the part to be removed.

When used with a bearing pulling attachment, the load to be applied should not exceed 2/3 of the nominal capacity of the cylinder.

As an option, we can supply legs of the dimensions indicated.

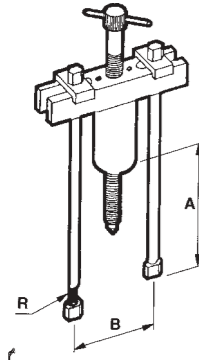

Nominal capacity tn	Ref.	Dimensions mm./in					Length of leg mm. in.	Mechanical set Ref.	Cylinder Ref.	Pump Ref.	Hose Ref.	Weight	
		A	Max. B	Min.	R	Kg.						lbs.	
10	TF-1	140 5 1/2	240 9 7/16	115 4 9/16	5/8 x 18	180 7 3/32	TFM-1	CSH-12	BM-04	A-5555	17	37,5	
20	TF-2	280 11 1/16	325 12 13/16	135 5 9/16	5/8 x 18	209 8 1/4	TFM-2	CSH-20	BM-04	A-5555	24	52,9	
30	TF-3	305 12	450 17 11/16	200 7 7/8	1 x 14	328 12 15/16	TFM-3	CSH-30	BM-04	A-5555	43	94,8	
50	TF-5	410 16 1/8	580 22 13/16	230 9 1/16	1 1/4 x 12	504 19 13/16	TFM-4	CSH-60	BM-1	A-5555	34	207,3	



### Grip pullers

As the G-12 is supplied with the triple crosshead, it may be turned into a three-grip puller with the addition of one grip.

The rest of the two-grip pullers require a triple crosshead and a leg to become a three-grip puller.

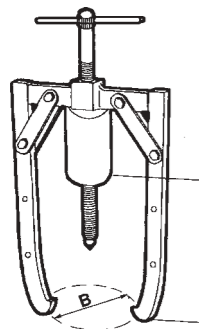

Nominal capacity tn	Ref.	Dimensions mm./in				Mechanical set Ref.	Cylinder Ref.	Pump Ref.	Hose Ref.	Weight	
		A Max.	B Max.							Kg.	lbs.
10	G-12	230 9 1/16	200 7 7/8		GM-12	CSH-12	BM-04	A-5555	16	35,3	
20	G-22	310 12 3/16	270 10 5/8		GM-22	CSH-20	BM-04	A-5555	22	48,5	
30	G-32	400 15 3/4	380 15		GM-32	CSH-30	BM-04	A-5555	36	79,4	
50	G-52	500 19 11/16	500 19 11/16		GM-52	CSH-60	BM-1	A-5555	85	187,4	



### Three-grip pullers

The G-13 model is supplied with double crosshead and triple crosshead.

All the other three-grip pullers require one double crosshead to be used as a two-grip puller.

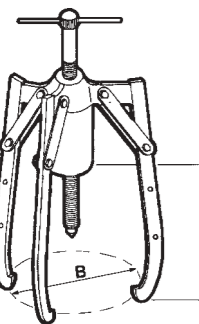

Nominal capacity tn	Ref.	Dimensions mm./in				Mechanical set Ref.	Cylinder Ref.	Pump Ref.	Hose Ref.	Weight	
		A Max.	B Max.							Kg.	lbs.
10	G-13	230 9 1/16	200 7 7/8		GM-13	CSH-12	BM-04	A-5555	18	39,7	
20	G-23	310 12 3/16	270 10 5/8		GM-23	CSH-20	BM-04	A-5555	27	59,5	
30	G-33	400 15 3/4	380 15		GM-33	CSH-30	BM-04	A-5555	45	99,2	
50	G-53	500 19 11/16	500 19 11/16		GM-53	CSH-60	BM-1	A-5555	103	227,1	



## Complete puller sets

### Bearing cup puller

They are used in combination with the rod pulling sets. Their legs are located with the grip outward for an easy removal of bushings, bearings, oil seals and other parts located in blind holes.

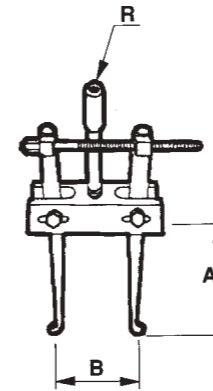

Nominal capacity tn	Ref.	Dimensions mm./in							Weight	
		A	Max. B	Min.	R	Kg.	lbs.			
10	IF-1	102 4 1/64	153 6 1/64	38 1 1/2	3/4 x 16 UNF	2,5	5,5			
20	IF-2	102 4 1/64	153 6 1/64	38 1 1/2	1 x 8 UNC	2,5	5,5			
30	IF-3	149 5 7/8	230 9 1/16	76 3	1 1/4 x 7 UNC	6	13,2			
50	IF-5	149 5 7/8	230 9 1/16	76 3	1 5/8 x 5 1/2 UNS	6	13,2			



### Bearing pulling attachment

These are also used in combination with the rod pulling sets.

The thickness of the edges have been flattened to permit placing this attachment behind the bearing to be pulled out.

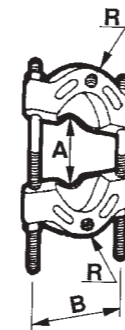

Nominal capacity tn	Ref.	Dimensions mm./in						Weight	
		Max. A	Min.	B	R	Kg.	lbs.		
10	A-5519	117 4 5/8	20 25/32	110 4 5/16	5/8 x 18	2,6	5,7		
20	A-5502	152 6	25 1	152 6	5/8 x 18	6,5	14,3		
30	A-5503	340 13 3/8	35 1 3/8	255 10 3/64	1 x 14	24	52,9		
50	A-5504	350 13 3/4	50 1 31/32	330 3	1 1/4 x 12	80	176,4		



### Complete puller sets

They consist of a pump, hose, cylinder, three-grip puller, bearing cup puller, double crosshead, bearing pulling attachment screw, screw cap and gauge

Each component can be supplied separately.



Nominal capacity tn	Ref.	2-grip	3-grip	Rod puller	Bearing cup puller	Bearing cup attachment	Cylinder	Pump	Hose	Gauge	Weight	
		Ref.	Ref.	Ref.	Ref.	Ref.	Ref.	Ref.	Ref.	Ref.	Kg.	lbs.
10	EHM-10	GM-12	GM-13	TFM-1	IFM-1	A-5519	CSH-12	BM-04	A-5555	A-5584G	32	70,5
20	EHM-20	GM-22	GM-23	TFM-2	IFM-2	A-5502	CSH-20	BM-04	A-5555	A-5584G	50	110,2
30	EHM-30	GM-32	GM-33	TFM-3	IFM-3	A-5503	CSH-30	BM-04	A-5555	A-5585G	100	220
50	EHM-50	GM-52	GM-53	TFM-5	IFM-5	A-5504	CSH-60	BM-1	A-5555	A-5585G	255	562



## Hydraulic Bottle jacks

They are the adequate and safe hydraulic tool for any lifting or pushing operation.

The base, pressure cylinder and oil deposit form one integral part and provide more strength and safety to the jacks.

Any pressure loads produced by the vehicle axle tilting are absorbed as the piston never comes into contact with the cylinder. therefore the jack will not be damaged even if the vehicle tilts.

Fitted with a safety relief valve ( optional up to 5 t ).

With hydraulic stroke limitation.

With carry handle for models MG-20 on.

The MGD-50 MGD-100 have two operating pumps: for approach and operation.

The MGD-100 includes pressure gauge.

All jacks can be manufactured with a gauge, upon request.

The MGT series combines low minimum height with higher lift because of the telescopic piston.



The MEGA jacks can be used horizontally with the pump downward as shown in the illustration.

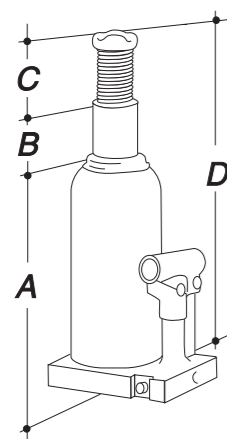

Maximum capacity tn	Ref.	Effective area		Dimensions mm/in.								Oil volume		Weight	
		cm <sup>2</sup>	in <sup>2</sup>	A				B				cm <sup>3</sup>	in <sup>3</sup>	Kg.	lbs.
				A	B	C	D	A	B	C	D				
2	MG-2	3,8	0,59	160	6 5/16	100	3 15/16	50	2	310	12 3/16	70	4,3	3,6	7,9
3	MG-3	5,3	0,82	168	6 5/8	105	4 1/8	65	2 9/16	338	13 5/16	85	5,2	3,9	8,6
3	MG-3-A	5,3	0,82	210	8 1/4	150	5 15/16	65	2 9/16	425	16 3/4	110	6,7	4,2	9,3
5	MG-5	8,04	1,26	212	8 11/32	150	5 15/16	75	2 15/16	437	17 3/16	160	9,75	5	11
8	MG-8	11,34	1,75	219	8 5/8	150	5 15/16	75	2 15/16	444	17 1/2	225	13,75	5,9	13
10	MG-10	14,52	2,25	219	8 5/8	150	5 15/16	75	2 15/16	444	17 1/2	275	16,75	6,5	14,3
12	MG-12	17,34	2,68	226	8 7/8	150	5 15/16	75	2 15/16	451	17 3/4	340	20,75	8	17,7
15	MG-15	21,23	3,29	228	8 15/16	150	5 15/16	75	2 15/16	453	17 13/16	410	25	9	19,8
20	MG-20	28,27	4,38	234	9 7/32	150	5 15/16	75	2 15/16	459	18 1/16	525	32	11,5	25,3
25	MG-25	38,48	5,96	240	9 7/16	150	5 15/16	75	2 15/16	465	18 5/16	740	45,1	15	33
30	MG-30	44,17	6,84	242	9 1/2	150	5 15/16	75	2 15/16	467	18 3/8	800	48,8	15,5	34,1
40	MG-40	58,08	9	246	9 11/16	150	5 15/16	---	---	396	15 9/16	1100	67,1	23,5	51,8
50	MG-50	73,89	11,45	252	9 15/16	150	5 15/16	---	---	402	15 13/16	1350	82,4	28,5	62,8
50	MGD-50	73,89	11,45	270	10 9/16	150	5 15/16	---	---	420	16 1/2	1350	82,4	40	88,2
100	MGD-100	165,1	25,6	300	11 13/16	150	5 15/16	---	---	450	17 3/4	3300	201,5	87	191,8
5	MGS-5	8,04	1,26	135	5 5/16	70	2 3/4	40	1 9/16	145	9 5/8	95	5,8	4,3	9,5
10	MGS-10	14,52	2,25	131	5 6/32	62	2 7/16	30	1 3/16	223	8 3/4	150	9,2	5,5	12,1
15	MGS-15	21,23	3,29	150	5 15/16	75	2 15/16	40	1 9/16	265	10 7/16	250	15,3	7,5	16,5
20	MGS-20	28,27	4,38	190	7 1/2	105	4 1/8	55	2 3/16	350	13 3/4	400	24,5	10	22
5	MGT-5	7,06	1,1	215	8 1/2	300	11 13/16	---	---	515	20 9/32	400	24,4	8,5	18,7
8	MGT-8	11,34	1,75	235	9 1/4	316	12 7/16	---	---	551	21 11/16	750	45,8	12	26,5
12	MGT-12	16,6	2,57	245	9 5/8	326	12 13/16	---	---	571	22 1/2	1050	64,1	17	37,5
20	MGT-20	28,27	4,38	180	7 3/32	205	8 1/16	---	---	385	15 6/32	1150	70,2	22	48,5

## Body repair kits

These kits are the indispensable tool for many hydraulic applications, specially for rescues and roadside service, spreading, lifting and pulling jobs where hydraulic force is required.

From a basic set consisting of a pump, hose and cylinder, the components supplied can be easily assembled to become the ideal hydraulic tool in spreading, straightening, pulling, pushing lifting and many other applications.



### IMPORTANT:

As the cylinders have a higher capacity than the components of the kit, specially chains, cylinder toes, tube extensions etc., they should never exceed half their nominal capacity when used with these accessories.

The SH-1 spreader should not be used beyond 1 t. Note that the maximum working load for the chain is : 1 t on GC-10 and 500 kg on GC-5



All the technical information related to pumps and cylinders of this chart is described on other pages of this catalogue.

### Components

Nº	Description	Capacity in t		
		5	10	20
		References		
		GC-5-S	GC-10-S	GC-20-M
1	PUMP	BM-04	BM-04	BM-04
2	CYLINDER	CC-5B	CC-10-B	CC-20-B
3	METAL BOX	A-5167	A-5067	A-5067
4	HOSE	A-5541	A-5541	A-5541
5	EXTENSION TUBE Nº1	A-5133	A-5033	A-5233
6	EXTENSION TUBE Nº2	A-5134	A-5034	A-5234
7	EXTENSION TUBE Nº3	A-5135	A-5035	A-5235
8	RUBBER SADDLE	A-5148	A-5048	---
9	SADDLE	A-5142	A-5042	A-5242
10	THREADED CONNECTOR	A-5138	A-5038	A-5238
11	V HEAD	A-5153	A-5053	---
12	WEDGE HEAD	A-5154	A-5054	---
13	FLAT BASE	A-5155	A-5055	A-5284*
14	PISTON TOE	A-5150	A-5050	A-5280*
15	TUBE CONNECTORS	A-5139	A-5039	A-5239
16	EXTENSION TUBE Nº4	A-5136	A-5036	---
17	LOCK PINS	A-5149	A-5049	---
18	SPREADER	SH-1	SH-1	---
19	SLIP LOCK EXTENSION	A-5143	A-5043	---
20	CHAIN	A-5186	A-5086	---
21	CHAIN PLATE	A-5157	A-5057	---
22	CLAMP HEAD	A-5158	A-5058	---
23	CHAIN YOKE	A-5156	A-5056	---
24	SLIP CLAM TOE	A-5151	A-5051	A-5252*
25	COLLAR TOE	A-5152	A-5052	---
WEIGHT kg/lbs		30 / 66,1	45/99	45/99

\* The components market with \* are different on GC-20-M

### Optional components

	CC-5-A	CC-10-A	CC-20-A
CYLINDER	CC-5-A	CC-10-A	CC-20-A
PULLING CYLINDER	CT-2,5	CT-5	CT-10
FOOT PUMP	BMP-1	BMP-1	BMP-1
AIR HYDRAULIC PUMP	NS-1	NS-1	NS-1

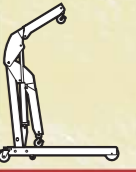

## Presses

We manufacture a wide range of frame and bench presses, designed for the application of a high force. Their compact and functional design integrates all the hydraulic elements within the chassis, thus ensuring protection in transport and saving space in the workshop.

They are fitted with workbench adjustable for height and winch to assist easy and rapid handling of the work bench, models KSC-15 A and AN excluded.

The KP-100 is equipped with a double-acting hydraulic cylinder, ref. CDRA-93F. For this configuration we recommend the use of the electric pump, ref. BED-20.

KPD and KP-100 models have two-speed hand pump, ref. BKD-09 and BMD-6.

As an option, all KPD models can be equipped with a manual and air powered pump, ref. BKN-09.

A set of two V blocks is included and the legs have holes to mount the press to the workshop floor. Supplied fully assembled and ready for use.

With pressure gauge and damper, positioned at the eye level to make for easy reading.



Set of plate, adapter and punches (optional)

- A-5552/ 15 for 15t presses.
- A-5552/ 30 for 30 and 50t presses.
- Ø 12 - 15/32
- Ø 16 - 5/8
- Ø 18 - 45/64
- Ø 20 - 25/32
- Ø 22 - 55/64
- Ø 25 - 63/64
- Ø 30 - 1 7/32



Sliding cylinder along the press head on KPD models.

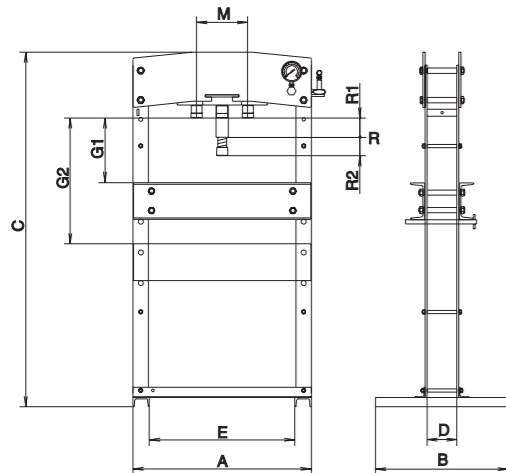

	Capacity in t			
	15	30	50	100
	References			
With hand pump	KSC-15A	KPD-30A	KPD-50A	KP-100
With manual/air pump	KSC-15AN	KPD-30AN	KPD-50AN	
With electric pump		KPD-30AE	KPD-50AE	KP-100E
	Dimensions mm/in.			
A	605 23 13/16	880 34 5/8	880 34 5/8	1250 49 7/32
B	420 16 1/2	650 25 5/8	650 25 5/8	1000 39 3/8
C	940 37	1770 69 11/16	1810 71 1/4	2000 78 3/4
D	120 4 3/4	145 5 11/16	145 5 11/16	300 11 13/16
E	500 19 11/16	710 27 15/16	710 27 15/16	1000 39 3/8
G1 Minimum	150 5 7/8	165 6 1/2	165 6 1/2	130 5 1/8
G2 Maximum	450 17 11/16	615 24 7/32	615 24 7/32	930 36 5/8
R1 Hydraulic stroke	95 3 3/4	120 4 3/4	120 4 3/4	250 9 13/16
R2 Extension stroke	75 2 15/16	75 2 15/16	75 2 15/16	---
R Total stroke	170 6 11/16	195 7 11/16	195 7 11/16	250 9 13/16
M Side stroke	---	250 9 13/16	250 9 13/16	---
Weight kg/lbs	77 / 170	203,5 / 448	239 / 527	939 / 2070

## Cranes

Foldable and portable. These cranes require only a small space, are quickly foldable, and easily movable thanks to the fixed auxiliary wheels which, made from polyamide, facilitate manoeuvrability, do not damage garage floors, do not rust and are quiet in operation.

They feature safety relief valve, dead man's principle operation, automatic, lowering control system and hydraulic limitation of stroke.

They included other important features such as a 135° swivel hydraulic unit to facilitate users' s position and extendable jib with handle to make easy the position of the arm.

The legs on FC-5A and FC-10A have a height of 80 mm to be used where space is tight.



- Swivel hydraulic unit up to 135° to facilitates user's position with respect to load. Pump piston spring improves operation.
- Lifting and lowering ergonomic pump handle, with dead man's principle operation.
- Legs of 80 mm minimum height on FC-5A and FC-10A for use in areas of very low clearance.
- Extendable jib with handle to facility its position on the lifting arm. With openings which indicate lifting capacity on each point.

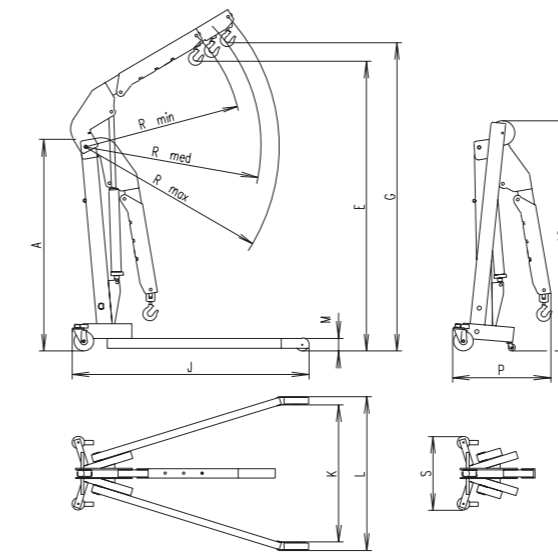

	References					
	FC-5A		FC-10A		FC-20A	
	Capacity in kg / lbs					
POSITION 1	500	1102	1000	2204	2000	3306
POSITION 2	400	882	800	1764	1750	3858
POSITION 3	325	716	700	1543	1650	3638
	Dimensions mm/in.					
A	1400	55 1/64	1675	66	1720	67 3/4
A2	1400	55 1/64	1675	66	1790	70 1/2
E	1970	77 9/16	2275	89 1/2	2340	92 1/8
G	2080	81 7/8	2416	95	2500	98 7/16
J	1500	59	1695	66 3/4	1900	74 13/16
K	820	32 1/4	935	36 13/16	1035	40 3/4
L	970	38 3/16	1085	42 3/4	1160	45 11/16
M	80	3 5/32	80	3 5/32	200	7 7/8
R Min.	1050	41 5/16	1260	49 5/8	1275	50 3/16
R Med.	1150	45 1/4	1405	55 5/16	1420	55 7/8
R Max.	1250	49 7/32	1550	61	1570	61 13/16
P	465	18 5/16	545	21 7/16	635	25
S	450	17 11/16	450	17 3/4	570	22 7/16
Weight kg / lbs	92 / 203		121 / 267		173 / 381	

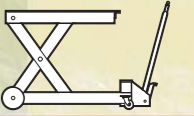

## Hydraulic pipe benders

### For Din 2440 and DIN 2441 GAS pipes

Bending angles up to 180°.

Supplied with tripod stand, wooden cases and the following set of formers:

CVT-2: 1/2" - 3/4" - 1 - 1 1/4" - 1 1/2" and 2".

CVT-3: 1/2" - 3/4" - 1 - 1 1/4" - 1 1/2" - 2" - 2 1/2" and 3".

Fitted with retractable bending frames, permanently marked, to facilitate easier position of bending supports and pipe to bend.

Equipped with safety relief valve and hydraulic limitation of stroke.

Piston retracts automatically when the release valve is opened.

Complete instructions for use, maintenance and bending jobs are supplied with the machine.

Any bending job can be carried out without physical effort thanks to the high force deployed by the hydraulic unit: 15t on CVT-2 and 20t on CVT-3.



Capacity	Reference	Pipes up to	Weight	
			Kg.	lbs.
15	CVT-2	2"	71	157
20	CVT-3	3"	28	283

## Rail benders

The set consists of pump, hose and cylinder and is manufactured to bend rails of 20 kg/m and 30 kg/m.

Spring return

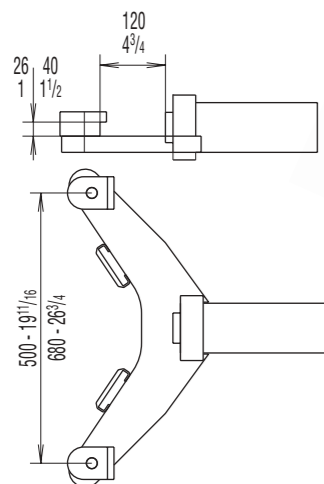

Capacity	Reference	Cylinder	Pump	Weight
tn		Ref.	Ref.	Kg.
25	CVR-25	CSA-25-C	BM-1	38
50	CVR-50	----	BM-1	51

## Hydraulic lifting tables

Widely used in workshop and industry for maintenance jobs.

They are equipped with dead man's principle operation, safety relief valve, automatic lowering control system and hydraulic limitation of stroke.

Can be locked at different heights with the safety bolts provided.

With foot pedal for quick approach to load, ME-650 excluded.



Table wheels fitted with foot protection and brakes.

Foot pedal for quick approach to load, ME-650 excluded.

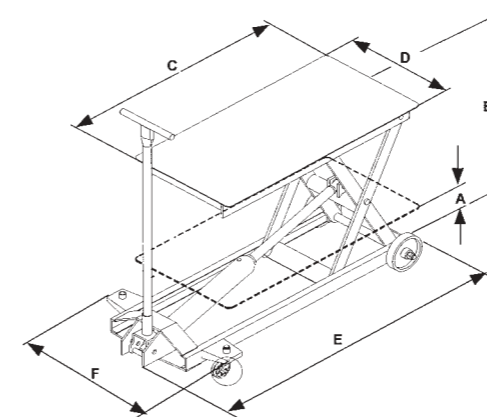

Safety distance between scissors and between the lifting platform and chassis.

	Capacity Kg./lbs.									
	650	1433	650	1433	1200	2646	1500	3307	2500	5512
	References									
	MEP-650	ME-650	ME-1200	ME-1500	ME-2500					
Dimensions in mm / in										
A	320	12 9/16	215	8 7/16	250	9 7/8	210	8 1/4	300	11 13/16
B	755	29 3/4	645	25 3/8	840	33	880	34 5/8	880	34 5/8
C	830	32 11/16	830	32 11/16	1020	40 6/32	1020	40 6/32	1060	41 3/4
D	500	19 11/16	500	19 11/16	500	19 11/16	500	19 11/16	540	21 1/4
E	1060	41 3/4	1060	41 3/4	1380	54 5/16	1380	54 5/16	1440	56 11/16
F	570	22 7/16	530	20 7/8	690	27 3/16	690	27 3/16	795	31 5/16
Weight kg./lbs.	74,5 / 164		71 / 57		98 / 216		135 / 298		187 / 412	

## SPECIAL EQUIPMENT



Custom-made equipment, featuring characteristics different from those indicated in this catalogue, can be supplied on request. We also manufacture hydraulic equipment for special applications such as telescopic cylinders, aircraft jacks, shaft propeller hydraulic pullers for use in naval industry etc.

We always have a hydraulic solution for your specific problem.

**Technical information to be given with your request.**

### Cylinder:

Capacity:	<input type="text"/>	t	Single-acting	<input type="checkbox"/>	Telescopic	<input type="checkbox"/>
Stroke:	<input type="text"/>	mm	Double-acting	<input type="checkbox"/>	Compression load cell	<input type="checkbox"/>
Working pressure:	<input type="text"/>	bar	Safety nut	<input type="checkbox"/>	Tension load cell	<input type="checkbox"/>
Quantity:	<input type="text"/>		Hollow cylinder	<input type="checkbox"/>	Others	<input type="checkbox"/>
			Spring return	<input type="checkbox"/>	Minimum height:	<input type="text"/> mm
			Pulling cylinder	<input type="checkbox"/>	Outside diameter:	<input type="text"/> mm
					Type of saddle	<input type="text"/>

**Note:** Other type of equipment not included above will require a sketch.

## GARAGE EQUIPMENT

We also manufacture a great variety of hydraulic lifting equipment for garage and general industry. We have a comprehensive catalogue covering these items which is available upon request or at our web site: [www.mega.es](http://www.mega.es)

